

Mitsubishi Electric AC Servo System

MITSUBISHI ELECTRIC SERVO SYSTEM
MELSERVO-J5

MR-J5D
User's Manual
(Hardware)

-MR-J5D_-_G_
-MR-J5D_-_G_-_N1

SAFETY INSTRUCTIONS

Please read the instructions carefully before using the equipment.

To use the equipment correctly, do not attempt to install, operate, maintain, or inspect the equipment until you have read through this manual, installation guide, and appended documents carefully. Do not use the equipment until you have a full knowledge of the equipment, safety information and instructions.

In this manual, the safety instruction levels are classified into "WARNING" and "CAUTION".



WARNING

Indicates that incorrect handling may cause hazardous conditions, resulting in death or severe injury.



CAUTION

Indicates that incorrect handling may cause hazardous conditions, resulting in medium or slight injury.

Note that the CAUTION level may lead to a serious consequence depending on conditions.

Please follow the instructions of both levels because they are important to personnel safety.

Forbidden actions and required actions are indicated by the following diagrammatic symbols.



Indicates a forbidden action. For example, "No Fire" is indicated by .



Indicates a required action. For example, grounding is indicated by .

In this manual, precautions for hazards that can lead to property damage, instructions for other functions, and other information are shown separately in the "POINT" area.

After reading this manual, keep it accessible to the operator.

[Transportation]

CAUTION

- To prevent injury, transport the products correctly according to their mass.
-

[Installation/wiring]

WARNING

- To prevent an electric shock, turn off the power and wait for 20 minutes or more before starting wiring and/or inspection.
 - To prevent an electric shock, ground the converter unit/drive unit.
 - To prevent an electric shock, any person who is involved in wiring should be fully competent to do the work.
 - To prevent an electric shock, do not attempt to wire the converter unit/drive unit until it has been mounted.
 - To prevent an electric shock, connect the protective earth (PE) terminal of the converter unit/drive unit to the protective earth (PE) of the cabinet, then connect the grounding lead wire to the ground.
 - To prevent an electric shock, do not touch the conductive parts.
-

[Setting/adjustment]

WARNING

- To prevent an electric shock, do not operate the switches with wet hands.
-

[Operation]

WARNING

- To prevent an electric shock, do not operate the switches with wet hands.
-

[Maintenance]

WARNING

- To prevent an electric shock, any person who is involved in inspection should be fully competent to do the work.
 - To prevent an electric shock, do not operate the switches with wet hands.
-

ABOUT THE MANUAL

Point

e-Manuals are Mitsubishi Electric FA electronic book manuals that can be browsed with a dedicated tool.

e-Manuals enable the following:

- Searching for desired information in multiple manuals at the same time (manual cross searching)
- Jumping from a link in a manual to another manual for reference
- Browsing for hardware specifications by scrolling over the components shown in product illustrations
- Bookmarking frequently referenced information
- Copying sample programs to engineering tools

If using the servo for the first time, prepare and use the following related manuals to ensure that the servo is used safely. For the related manuals, refer to the User's Manual (Introduction).

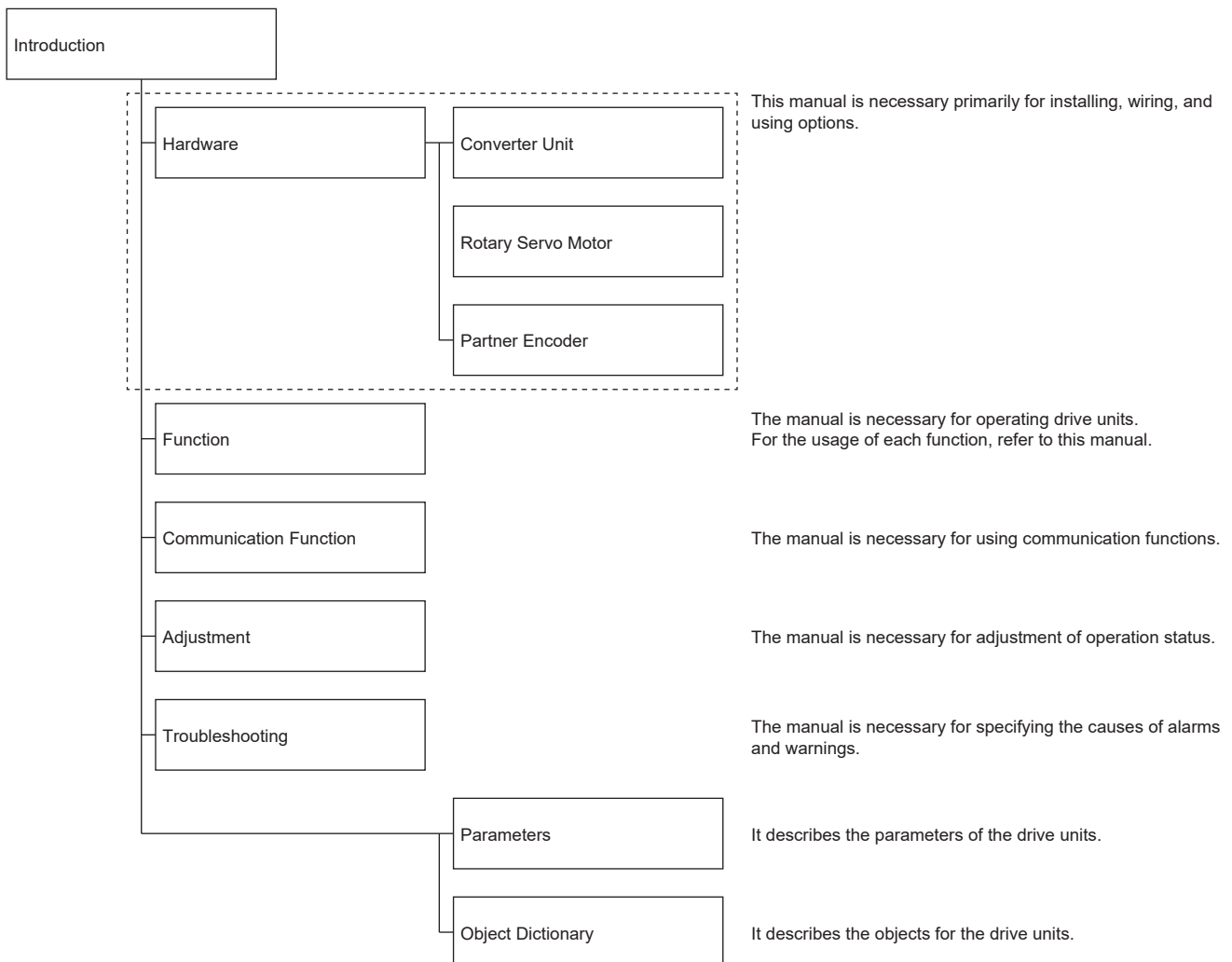

U.S. CUSTOMARY UNITS

U.S. customary units are not shown in this manual. Convert the values if necessary according to the following table.

Quantity	SI (metric) unit	U.S. customary unit
Mass	1 [kg]	2.2046 [lb]
Length	1 [mm]	0.03937 [inch]
Torque	1 [N•m]	141.6 [oz•inch]
Moment of inertia	1 [$\times 10^{-4}$ kg•m ²]	5.4675 [oz•inch ²]
Load (thrust load/axial load)	1 [N]	0.2248 [lbf]
Temperature	N [$^{\circ}$ C] \times 9/5 + 32	N [$^{\circ}$ F]

CONTENTS

SAFETY INSTRUCTIONS	1
ABOUT THE MANUAL	3
U.S. CUSTOMARY UNITS	4
CHAPTER 1 INTRODUCTION	9
1.1 Wiring procedure	9
1.2 Combination with converter units and drive units	10
Combination with power regeneration converter units and drive units	10
1.3 Combination with drive units and servo motors	12
Rotary servo motor	12
1.4 Wiring check	14
Power supply system wiring	14
I/O signal wiring	15
1.5 Surrounding environment	16
CHAPTER 2 INSTALLATION	17
2.1 Mounting direction and clearances	18
Installation	18
Mounting hole location diagram	19
2.2 Keeping out foreign materials	21
2.3 Cable stress	21
2.4 Fan unit replacement procedure	21
List of applicable fan units	21
Fan unit removal procedure	22
Fan unit installation procedure	23
2.5 IP20 compatible terminal block	24
Side protection cover	24
Side protection cover installation procedure	25
2.6 Restrictions when using this product at an altitude exceeding 1000 m and up to 2000 m	26
2.7 Installing the mounting attachment	27
Selection of attachment for power regeneration converter units	28
Selecting the attachment for drive units	30
Dimensions when installing the mounting attachment	31
CHAPTER 3 SIGNALS AND WIRING	41
3.1 Example power circuit connections	42
Drive unit termination settings	42
How to use the bus bar	47
3.2 Example I/O signal connections	48
MR-J5D1-_G_	49
MR-J5D2-_G_/MR-J5D3-_G_	51
3.3 Explanation of power supply system	54
Explanation of signals	54
Power-on procedure	54
Wiring CNP3_	56
3.4 Connectors and pin assignments	59
Precautions	59
Connectors and pin assignments	60

3.5	Signal (device) explanation	62
	Input device	62
	Output device	66
	Output signal	71
	Power supply	72
3.6	Interface	73
	Internal connection diagram	73
	Detailed explanation of interfaces	77
	Source I/O interface	80
3.7	Servo motor with an electromagnetic brake	81
	Connection diagram	81
3.8	Grounding	83
CHAPTER 4 DIMENSIONS		84
4.1	400 V class	84
4.2	Connector	91
	CN3 connector	91
	SCR connector system (3M)	91
CHAPTER 5 CHARACTERISTICS		92
5.1	Overload protection characteristics	92
5.2	Power supply capacity and generated loss	94
	Power supply capacity	94
	Generated loss	94
5.3	Dynamic brake characteristics	96
	Dynamic brake operation	97
5.4	Cable flex life	112
5.5	Inrush currents at power-on of control circuit	113
CHAPTER 6 OPTIONS AND PERIPHERAL EQUIPMENT		114
6.1	Cables/connector sets	114
	Combinations of cables/connector sets	115
	MR-D05UDL3M-B STO cable	117
	Ethernet cable	118
	Bus bar	119
6.2	MR Configurator2	120
	Engineering tool	120
	Precautions for using USB communication function and Ethernet communication function	120
6.3	Selection example of wires	121
6.4	Molded-case circuit breakers, fuses	123
	Selection example (for control circuit power supply)	123
	Selection examples that comply with IEC/EN/UL 61800-5-1 and CSA C22.2 No.274	125
6.5	Relay (recommended)	126
6.6	Noise reduction techniques	126
	Noise reduction techniques	126
	Noise reduction products	131
6.7	Earth-leakage current breaker	134
CHAPTER 7 ABSOLUTE POSITION DETECTION SYSTEM		135
7.1	Outline	135

Characteristics	135
Restrictions [G]	135
Precautions	135
System architecture	136
Servo parameter setting [G]	136
Homing	136
Checking the detected absolute position data	137
Procedure of replacing a servo motor with battery-less absolute position encoder	137
7.2 Configuration and specifications	138
Connecting the battery-less encoder	138
CHAPTER 8 USING STO FUNCTION	139
<hr/>	
8.1 Introduction	139
Outline	139
Terms related to safety	139
Precautions	139
Residual risks of the STO function	140
Specifications	141
Maintenance	141
8.2 Functional safety I/O signal connector (CN8) and pin assignments	142
Pin assignment	142
Signal (device) explanation	142
How to pull out the STO cable	143
8.3 Connection example	144
Precautions for compliance with stop category 1 (IEC/EN 60204-1)	144
Precautions for compliance with stop category 0 (IEC/EN 60204-1)	144
Connection example for CN8 connector	145
External I/O signal connection example using an external safety relay unit	146
8.4 Detailed explanation of interfaces	147
Sink I/O interface	147
Source I/O interface	149
CHAPTER 9 USING FUNCTIONAL SAFETY	150
<hr/>	
9.1 Function block diagram	150
Safety sub-function control by input device	150
Safety sub-function control by network	151
9.2 System architecture	152
Safety sub-function control by input device	152
Safety sub-function control by network	153
9.3 Specifications	154
9.4 Connectors and pin assignments	154
9.5 Example I/O signal connections	155
Input signal	155
Output signal	156
9.6 Connecting I/O interfaces	157
Source input	157
Sink input	157
9.7 Wiring the SBC output	158
9.8 Noise reduction techniques	159
9.9 Example of connection with other devices	160

Safety sub-function control by input device	160
Safety sub-function control by network	161

CHAPTER 10 USING A FULLY CLOSED LOOP SYSTEM 162

10.1 Precautions	162
10.2 Functions and configuration	163
Outline	163
Function block diagram	164
Operation mode and load-side encoder combinations	165
System architecture	166
10.3 Signals and wiring	169
Encoder cable configuration diagram	169
10.4 Startup	171
Servo parameter setting	171
Checking position data of the load-side encoder	176
10.5 Basic functions	177
Homing	177
Operation from controller	181
Fully closed loop control error detection function	181
About MR Configurator2	183
10.6 Options and peripheral equipment	185
MR-J4FCCBL03M branch cable	185
10.7 Absolute position detection system	186
REVISIONS	188
WARRANTY	189
TRADEMARKS	190

1 INTRODUCTION

1.1 Wiring procedure

Procedure	Description	Reference
1. Installation	Install the converter unit/drive unit.	☞ Page 17 INSTALLATION
2. Connecting the power circuit	Connect the power circuit.	☞ Page 42 Example power circuit connections
3. Connecting I/O signals	Connect I/O signals.	☞ Page 48 Example I/O signal connections
4. Connecting to the servo motor	Connect the drive unit and servo motor. If using the drive unit in a fully closed loop system, connect the drive unit to a linear encoder or a rotary encoder.	📖 Rotary Servo Motor User's Manual (HK series) ☞ Page 162 USING A FULLY CLOSED LOOP SYSTEM
5. Connecting options	Connect options.	☞ Page 114 OPTIONS AND PERIPHERAL EQUIPMENT
6. Other precautions	If using the absolute position detection system and the functional safety, perform wiring and settings as necessary.	☞ Page 135 ABSOLUTE POSITION DETECTION SYSTEM ☞ Page 139 USING STO FUNCTION ☞ Page 150 USING FUNCTIONAL SAFETY
7. Wiring check	Check that the converter unit, drive unit, and the servo motor are wired correctly by visually inspecting them or by using a method such as the DO forced output function.	☞ Page 14 Wiring check
8. Checking the surrounding environment	Check the environment surrounding the converter unit, drive unit, and servo motor.	☞ Page 16 Surrounding environment

1.2 Combination with converter units and drive units

Combination with power regeneration converter units and drive units

Selection method

Use the following conditions to select a power regeneration converter unit. By satisfying all the conditions, multiple drive units can be connected to one power regeneration converter unit. When connecting multiple drive units, arrange them in descending order of capacity per axis of the drive unit from the right side of the power regeneration converter unit.

- Effective value of total output power of servo motors [kW] \leq Continuous rating of the MR-CV_ [kW]
- Maximum value of total output power of servo motors [kW] $\times 1.2 \leq$ Instantaneous maximum rating of the MR-CV_ [kW]
- Total unit width of the MR-J5D_ ≤ 1500 mm

MR-CV_	11K4	18K4	30K4	37K4	45K4	55K4	75K4
Continuous rating [kW]	7.5	11	20	25	25	55	55
Instantaneous maximum rating [kW]	39	60	92	101	125	175	180
Total unit width of the MR-J5D_	1500 mm or less						

Item	MR-J5D1_					MR-J5D2_					MR-J5D3_			
	100G4	200G4	350G4	500G4	700G4	100G4	200G4	350G4	500G4	700G4	100G4	200G4		
Unit width [mm]	60					60					75		60	

Selection example

The following information explains how to select a power regeneration converter unit to connect the drive units and servo motors listed below.

Drive unit	Servo motor
MR-J5D2-700G4	HK-ST7024M
	HK-ST5024M
MR-J5D3-200G4	HK-ST2024M
	HK-ST2024M
	HK-ST2024M

1. Use the following formula to calculate the running power and regenerative power of each servo motor from the servo motor speed and torque.

Running power and regenerative power [W] = Servo motor speed [r/min] × Torque [N•m]/9.55

2. Calculate the total output power of the servo motors from the running power and regenerative power of each servo motor.

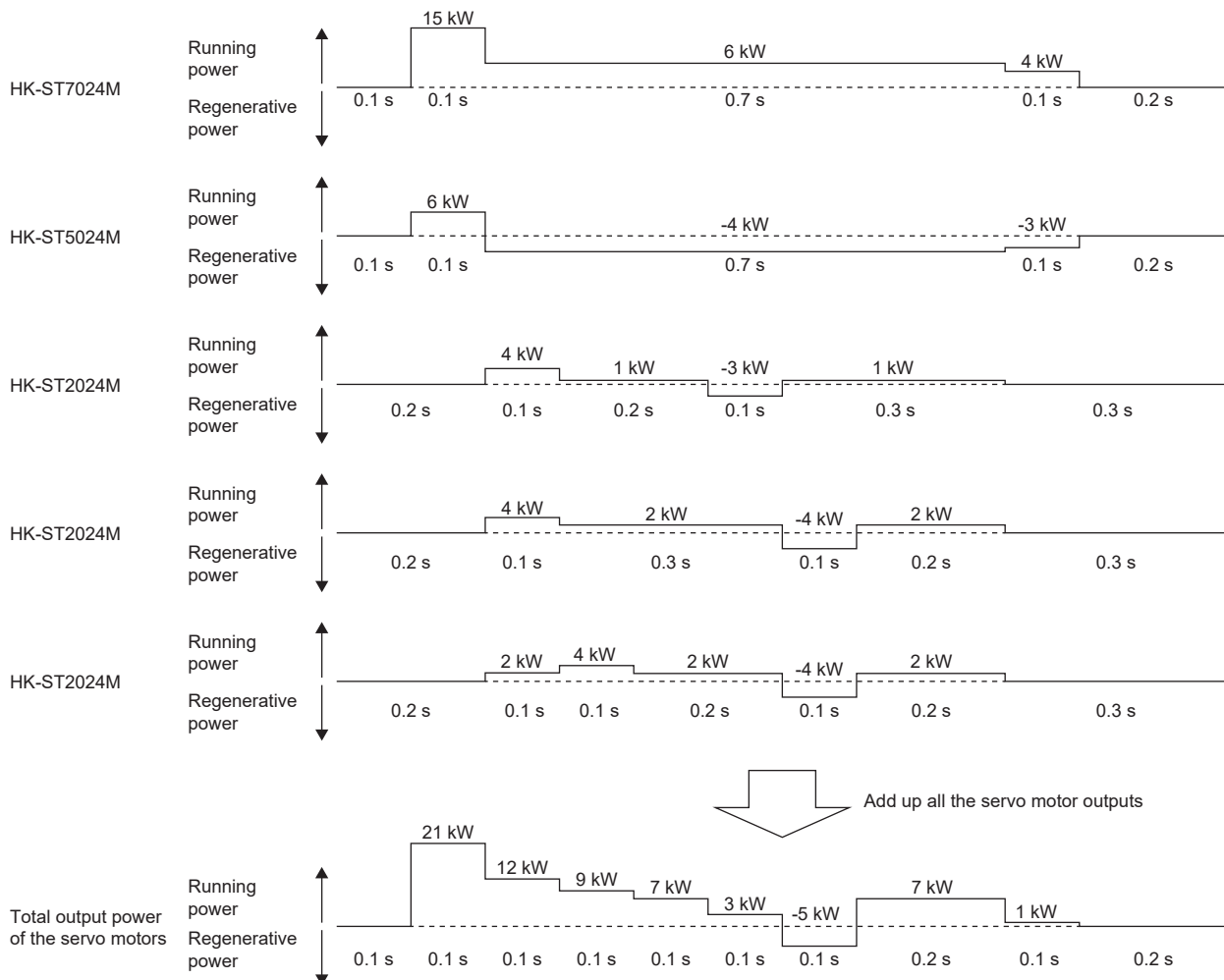

- The effective value of the total servo motor output power [kW]

$$= \sqrt{\sum_{n=1}^N (P_n^2 \times t_n) / T} \quad (P_n: \text{power running/regenerative power (kW)}, t_n: \text{power output time (s)}, T: \text{one cycle time (s)})$$

$$= \sqrt{(21^2 \times 0.1 + 12^2 \times 0.1 + 9^2 \times 0.1 + 7^2 \times 0.1 + 3^2 \times 0.1 + (-5)^2 \times 0.1 + 7^2 \times 0.2 + 1^2 \times 0.1) / 1.2} = 8.4 \text{ kW}$$

⇒ MR-CV18K4 or more

- Maximum value of the total servo motor output power [kW] × 1.2 = 21 kW × 1.2 = 25.2 kW

⇒ MR-CV11K4 or more

- Total drive unit width = 75 mm (MR-J5D2-700G4) + 60 mm (MR-J5D3-200G4) = 135 mm ≤ 1500 mm

Therefore, the power regeneration converter unit selected should be the "MR-CV18K4".

1.3 Combination with drive units and servo motors

By combining a servo motor with a larger capacity drive unit, the maximum torque can be increased to 400 % or 450 %.

Rotary servo motor

Point

As long as the servo motor is compatible with the drive unit, any combination of the servo motor series and capacity is possible.

HK-KT series

The combinations of geared servo motors and drive units are the same as those listed in the following table. However, for geared servo motors, the maximum torque does not increase even when they are combined with a drive unit whose combination allows for increased torque as specified in the following table.

■400 V class drive unit

○: Standard torque ◎: Increased torque

Rotary servo motor		Drive unit MR-J5D_-			
		100_4	200_4	350_4	
HK-KT_W	□40	HK-KT053W	◎ *1	—	
		HK-KT13W	◎ *1	—	
		HK-KT1M3W	◎ *1	—	
HK-KT_4_W	□60	HK-KT434W	◎ *1	—	
		HK-KT634W	○ *1	◎ *1	
	□80	HK-KT7M34W	○ *1	◎ *1	
		HK-KT1034W	○ *1	◎ *1	
	□90	HK-KT634UW	◎	◎	
		HK-KT1034UW	○	◎	
		HK-KT1534W	—	○ *1	
		HK-KT2034W	—	○ *1	
			HK-KT2024W	—	○ *1

*1 Use servo motors manufactured after September 2020. Otherwise, [AL. 01A Servo motor combination error] occurs.

HK-ST series

The combinations of geared servo motors and drive units are the same as those listed in the following table. However, for geared servo motors, the maximum torque does not increase even when they are combined with a drive unit whose combination allows for increased torque as specified in the following table.

■400 V class drive unit

○: Standard torque ◎: Increased torque

Rotary servo motor			Drive unit MR-J5D_-				
			100_4	200_4	350_4	500_4	700_4
HK-ST_4_W *1	□130	HK-ST524W	◎ *2	◎ *2	—	—	—
		HK-ST1024W	○ *2	◎ *2	◎ *2	—	—
		HK-ST1724W	—	○ *2	○ *2	○ *3	—
		HK-ST2024AW	—	○ *2	◎ *2	◎ *3	—
		HK-ST3024W	—	—	○ *2	◎ *3	◎ *3
		HK-ST3534W	—	—	○	◎	—
		HK-ST5034W	—	—	—	○	◎
	□176	HK-ST2024W	—	○ *2	◎ *2	◎ *3	—
		HK-ST3524W	—	—	○ *2	◎ *3	◎ *3
		HK-ST5024W	—	—	—	○ *3	◎ *3
		HK-ST7024W	—	—	—	—	○ *3

*1 The combinations of the HK-ST1524_G_ and drive units are the same as those for the HK-ST1724W.

*2 Use servo motors manufactured after December 2020. Otherwise, [AL. 01A Servo motor combination error] occurs.

*3 Use servo motors manufactured after April 2021. Otherwise, [AL. 01A] occurs.

HK-RT series

■400 V class drive unit

○: Standard torque ◎: Increased torque

Rotary servo motor			Drive unit MR-J5D_-				
			100_4	200_4	350_4	500_4	700_4
HK-RT_4W	□90	HK-RT1034W	○	◎	—	—	—
		HK-RT1534W	—	○	—	◎	—
		HK-RT2034W	—	○	◎	—	—
	□130	HK-RT3534W	—	—	○	◎	—
		HK-RT5034W	—	—	—	○	◎
		HK-RT7034W	—	—	—	—	○

1.4 Wiring check

Before switching on the main circuit and control circuit power supplies, check the following items.

Power supply system wiring

Power supply system wiring

- Check that the power supplied to the power input terminals (L11/L21) of the drive unit satisfies the defined specifications. For the power supply specifications, refer to "Drive unit standard specifications" in User's Manual (Introduction).

Connecting drive units and servo motors

- Check that the power supplied to the power input terminals (L11/L21) of the drive unit satisfies the defined specifications. For the power supply specifications, refer to "Drive unit standard specifications" in User's Manual (Introduction).
- Check that the CNP3A connector of the drive unit and A-axis servo motor, the CNP3B connector and B-axis servo motor, and the CNP3C connector and C-axis servo motor are connected, and that the phases (U/V/W) of the drive unit power outputs match with the phases (U/V/W) of the power inputs of each servo motor.

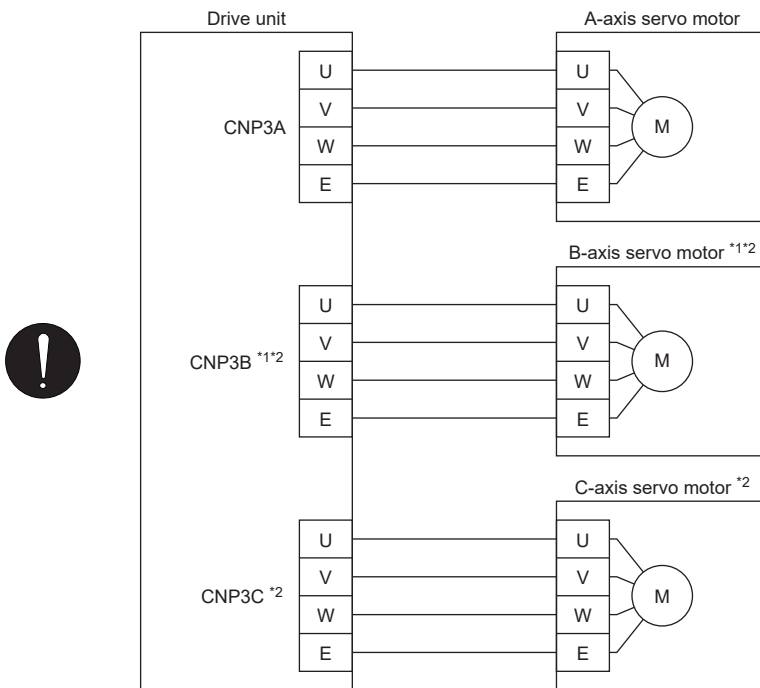

*1 For 2-axis drive units

*2 For 3-axis drive units

- Check that the power to be supplied to the converter unit is not connected to the power outputs (U/V/W) of the drive unit. Otherwise, the drive unit and the servo motor will malfunction.

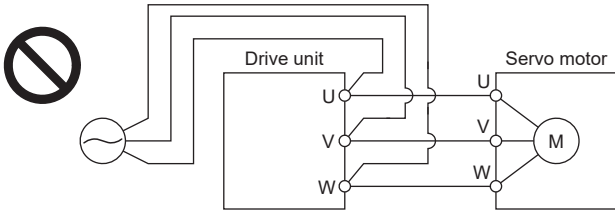

- Check that the grounding terminal of the servo motor is connected to the grounding terminal of the CNP3_ connector of the drive unit.

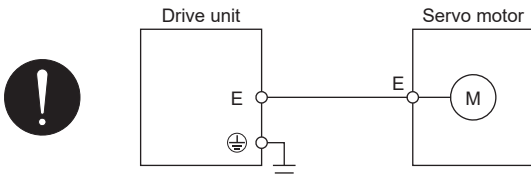

- Check that the CN2A connector and the encoder of the A-axis servo motor, the CN2B connector and the encoder of the B-axis servo motor, and the CN2C connector and the encoder of the C-axis servo motor are securely connected in the drive unit using a motor cable or encoder cable.

I/O signal wiring

- Check that I/O signals are connected correctly.

If the DO forced output mode is used, the pins of the CN3 connector can be forcibly switched on/off. This mode is used to check the wiring. In this case, switch on the control circuit power supply only. Refer to the following page for information on connecting I/O signals.

📖 Page 48 Example I/O signal connections

- Check that a voltage exceeding 24 V DC has not been applied to the pins of the CN3 connector.

1.5 Surrounding environment

Check the following items about the environment surrounding the converter unit, drive unit, and servo motor.

Handling cables

- Check that the wiring cables have not been stressed.
 - Check that the encoder cable has been used within its flex life.
- ☞ Page 112 Cable flex life
- Check that the connector of the servo motor has not been stressed.

Environment

Check that signal cables and power cables have not been shorted primarily by wire offcuts and metallic dust.

2 INSTALLATION

Precautions

- Mount the converter unit and drive unit on incombustible material. Installing them either directly on or near combustibles may lead to smoke or a fire. In addition, the converter unit and drive unit must be installed in a metal cabinet.
- Provide adequate protection so as to prevent conductive matter (such as screws and metal fragments) and combustible matter (such as oil) from entering the converter unit and drive unit.
- Devices such as the converter unit, drive unit, and servo motor may become hot. Take safety measures such as providing covers.
- Do not stack in excess of the specified number of product packages.
- Do not hold the front cover, cables, or connectors when carrying the converter unit and drive unit. Doing so may cause the drive unit to drop.
- To prevent a malfunction, do not drop the converter unit, drive unit, or servo motor or subject them to impacts.
- Install the converter unit, drive unit, and servo motor in a place that can support their weight as stated in the user's manual.
- Do not get on the equipment or put a heavy load on it.
- Do not install and operate a converter unit or drive unit that is missing parts or is damaged.
- To prevent a malfunction, do not block the intake and exhaust areas of the converter unit and drive unit.
- Do not subject connectors to impacts. Doing so may cause a connection failure, malfunction, or other failures.
- Use the product within the specified environment. For the environment, refer to "Drive unit standard specifications" in the User's Manual (Introduction).
- To prevent a fire or injury from occurring in the event of an earthquake or other natural disaster, securely install, mount, and wire the drive unit as stated in the user's manual.
- When the product has been stored for an extended period of time, contact your local sales office.
- When handling the converter unit and drive unit, pay attention to their corners.
- Fumigants that are used to disinfect and protect wooden packaging from insects contain halogens (such as fluorine, chlorine, bromine, and iodine) cause damage if they enter our products. Please take necessary precautions to ensure that any residual materials from fumigants do not enter our products, or perform disinfection and pest control using a method other than fumigation, such as heat treatment. Perform disinfection and pest control on the wooden packaging materials before packing the products.
- Provide an external emergency stop circuit to stop the operation and shut-off the power immediately.
- For equipment in which the moving part of the machine may collide against the load side, install a limit switch or stopper to the end of the moving part.
- Do not use the drive unit in environments where it is exposed to strong magnetic fields, electric fields, or radiation. Doing so may cause operation failure or malfunction.

2.1 Mounting direction and clearances

Precautions

- The converter unit and drive unit must be installed in the specified direction.
- To prevent a malfunction, maintain the specified clearances between the converter unit/drive unit and cabinet walls or other equipment.
- Circulate air so that the air at the top and bottom of the converter unit and drive unit does not stagnate.
- When using heat-generating equipment, install it with full consideration of heat generation so that the converter unit and drive unit are not affected.
- Mount the converter unit and drive unit on a perpendicular wall in the correct vertical direction.

Installation

MR-CV_ power regeneration converter unit/MR-J5D_ drive unit

Point

Connect the drive unit to the right side of the power regeneration converter unit as shown in the figure.

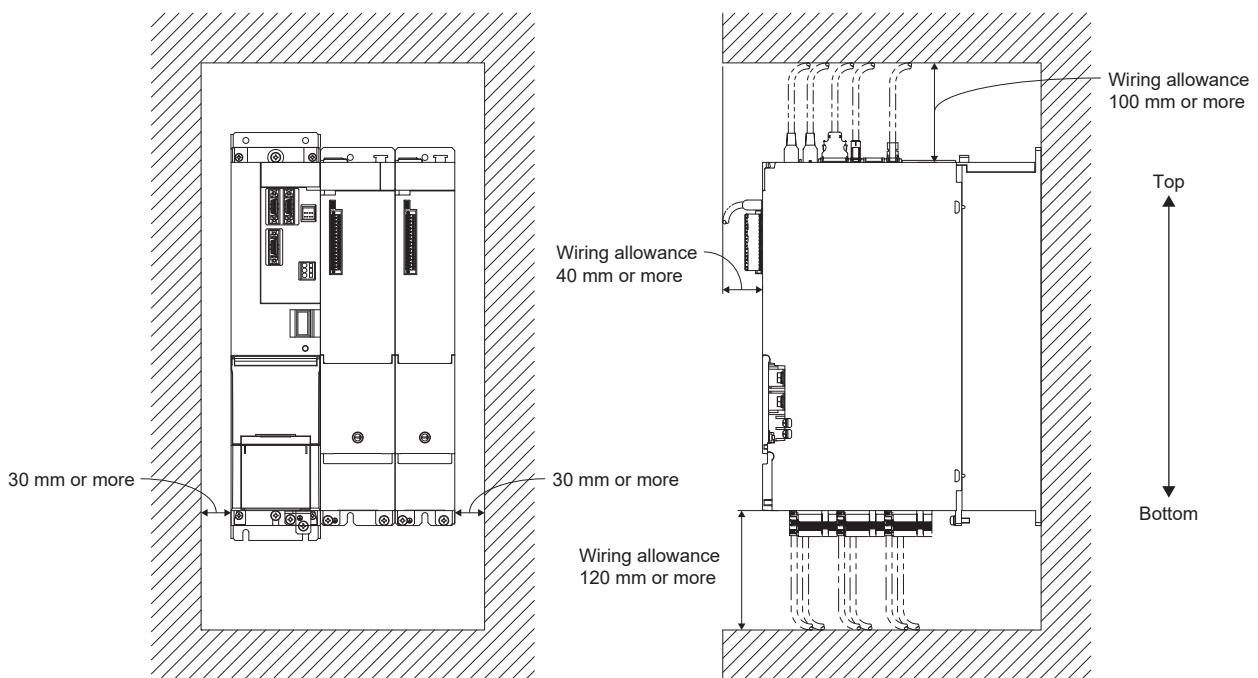

Mounting hole location diagram

MR-CV11K4/MR-CV18K4

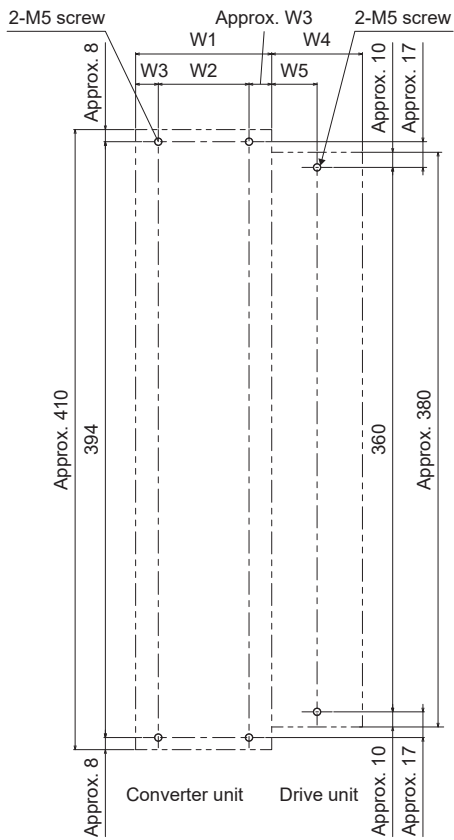

Drive unit/converter unit	Variable dimensions [mm]				
	W1	W2	W3	W4	W5
MR-CV11K4	90	60	15	—	—
MR-CV18K4	90	60	15	—	—
MR-J5D (60 width)	—	—	—	60	30
MR-J5D (75 width)	—	—	—	75	30

MR-CV30K4 to MR-CV75K4

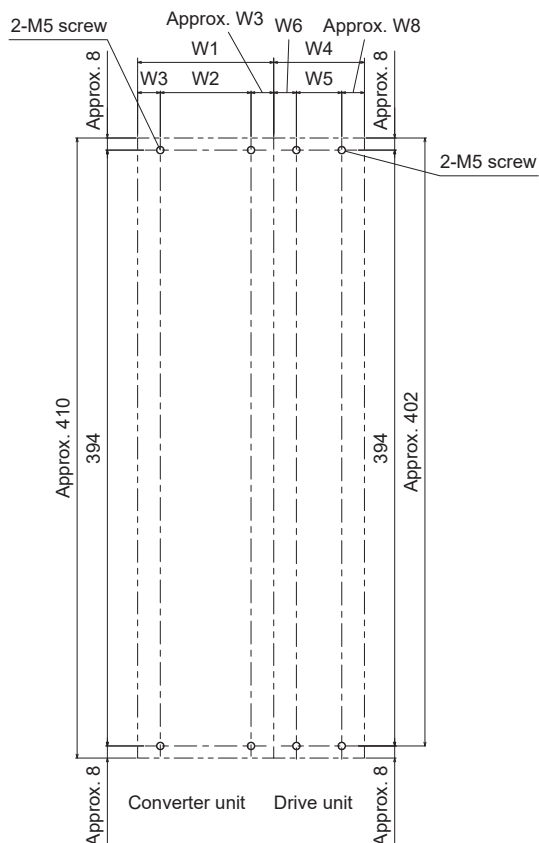

Drive unit/converter unit	Variable dimensions [mm]					
	W1	W2	W3	W4	W5	W6
MR-CV30K4	150	90	30	—	—	—
MR-CV37K4	150	90	30	—	—	—
MR-CV45K4	150	90	30	—	—	—
MR-CV55K4	300	240	30	—	—	—
MR-CV75K4	300	240	30	—	—	—
MR-J5D (60 width)	—	—	—	60	30	15
MR-J5D (75 width)	—	—	—	75	45	15

2.2 Keeping out foreign materials

When drilling the cabinet for assembly, prevent drill chips and wire fragments from entering the converter unit and drive unit. Prevent foreign matter such as oil, water, and metallic dust from entering the converter unit and drive unit through cooling fans installed in openings in the cabinet or on the ceiling.

When installing the cabinet in a place where toxic gas, dirt, and dust exist, conduct an air purge (force clean air into the cabinet from outside to make the internal pressure higher than the external pressure) to prevent such materials from entering the cabinet.

2.3 Cable stress

- The method used to clamp the cable must be fully examined so that bending stress and cable's own weight stress are not applied to the cable connection.
- When used for applications where the servo motor moves, fix the cable (encoder, power supply, brake) with gentle slack from the connecting part of the connector to prevent stress from being applied to the connecting part of the servo motor connector. Use the optional motor cable/encoder cable within the flex life range.
- Prevent the cable insulator from being cut by sharp chips or from touching and rubbing against the machine corners.
- Prevent the cables from getting stepped on by workers or run over by vehicles.
- If installing the servo motor that moves on a machine, make the bend radius as large as possible. Refer to the following for the flex life.

 Page 112 Cable flex life

Precautions

- The cables should not be damaged, stressed, loaded, or pinched.

2.4 Fan unit replacement procedure

The fan unit is composed of a cooling fan and its cover. If replacing the cooling fan, replace the entire fan unit.

In addition, shut off the main circuit power supply and control circuit power supply and wait at least 20 minutes before replacing the fan unit.

List of applicable fan units

Drive unit	Model of fan unit to be replaced
MR-J5D1-500G4 MR-J5D1-700G4 MR-J5D2-200G4 MR-J5D2-350G4 MR-J5D3-200G4	MR-J5D-FAN1
MR-J5D2-500G4 MR-J5D2-700G4	MR-J5D-FAN2

Fan unit removal procedure

1. Remove the screws that fixed the fan unit. Keep the removed screws for installation of the new fan unit.

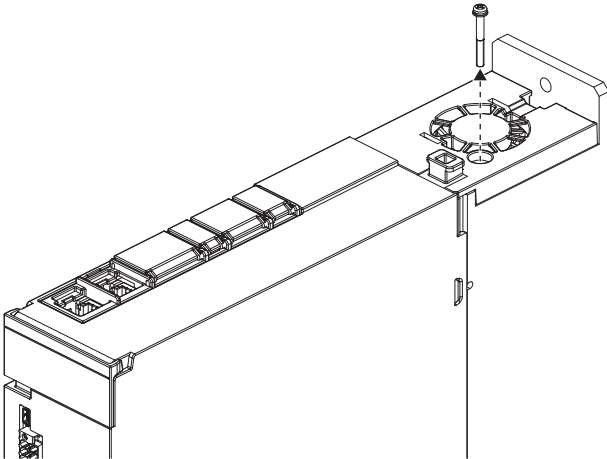

2. Pull out the fan unit vertically.

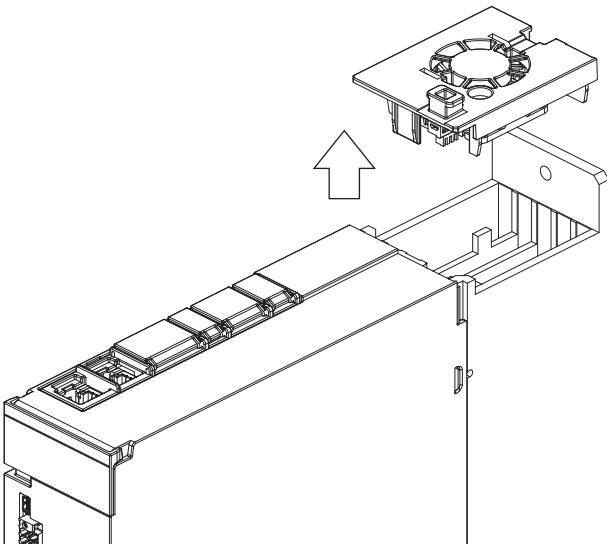

Fan unit installation procedure

1. Insert the positioning part of the fan unit vertically while aligning it to the positioning part of the main unit case.

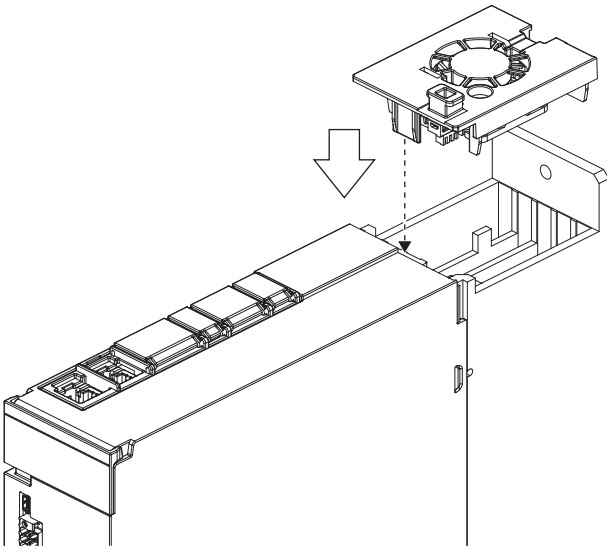

2. Tighten the fan unit with screws. Use the same screws as those used for the fan unit before replacement.

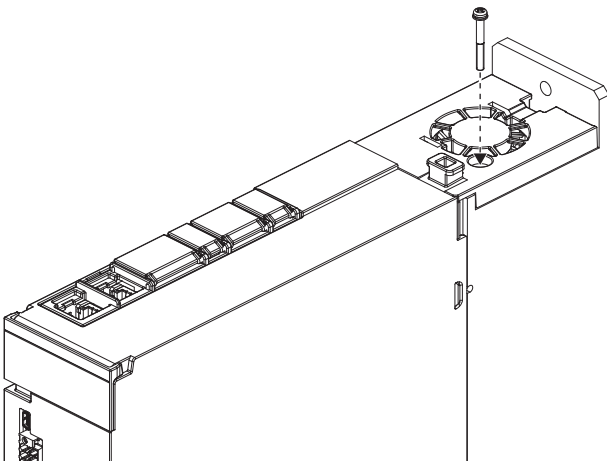

2.5 IP20 compatible terminal block

Attach the side protection cover (optional) to the rightmost unit and lock the terminal block cover so that the terminal block conforms to IP20. The external dimensions before and after mounting the side protection cover do not change.

Side protection cover

Drive unit	Side protection cover model
MR-J5D_	MR-J5DCASE01

Dimensions

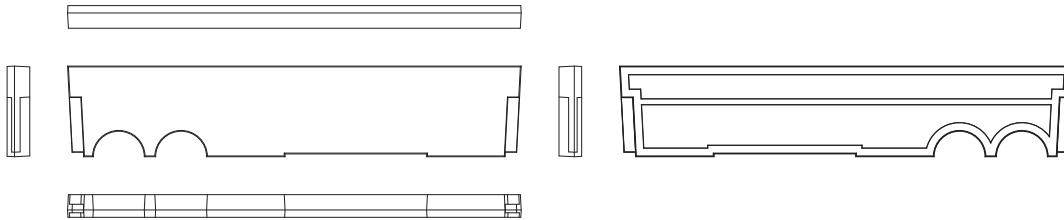

Side protection cover installation procedure

1. Set the lock of the terminal block cover to "OPEN". (Turn it counterclockwise.)

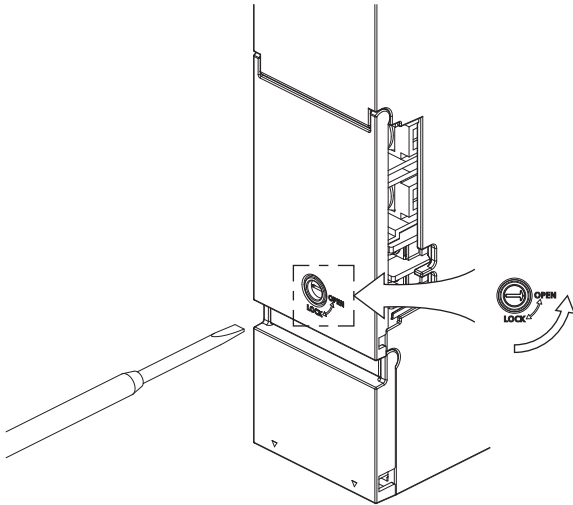

2. Open the terminal block cover and insert the side protection cover along the slit on the right side of the terminal block. If the control circuit power supply is wired from the right side, pass the wire through the groove on the side cover to prevent it from getting caught.

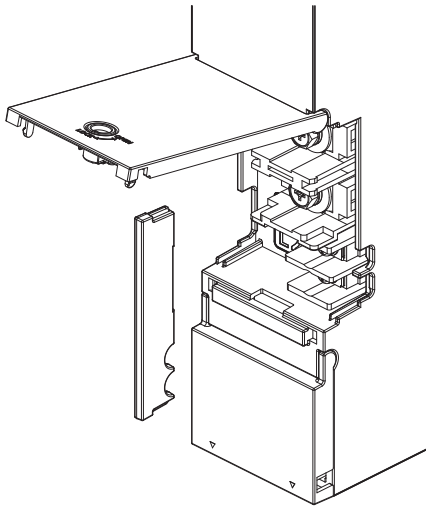

3. Close the terminal block cover and set the lock of the terminal block cover to "LOCK". (Turn it clockwise.)

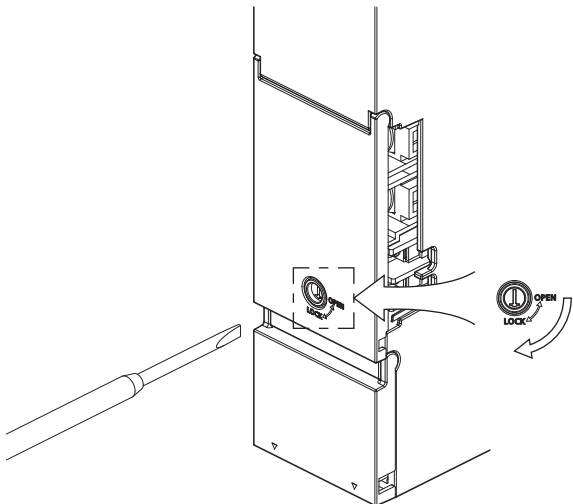

2.6 Restrictions when using this product at an altitude exceeding 1000 m and up to 2000 m

Refer to "Restrictions when using this product at an altitude exceeding 1000 m and up to 2000 m" in the following manual for converter unit restrictions.

📖MR-CV Power Regeneration Converter Unit User's Manual

Altitude and ambient temperature

As heat dissipation effects decrease in proportion to the decrease in air density (5 °C per 1000 m), use the product within the ambient temperature range shown in the following figure.

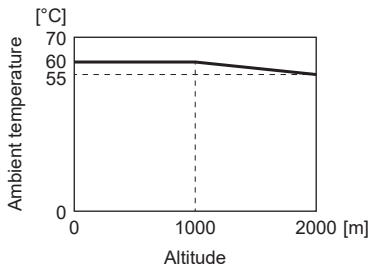

Input voltage

Generally, withstand voltage decreases as altitude increases; however, there is no restriction on the withstand voltage.

Parts with a service life

■Smoothing capacitor

The capacitor will reach the end of its service life in 10 years of continuous operation in an air-conditioned environment (with an ambient temperature of 30 °C or less).

■Relays

There is no restriction.

■Drive unit cooling fan

There is no restriction.

2.7 Installing the mounting attachment

The mounting attachment is required to mount the power regeneration converter unit to the cabinet.

List of applicable mounting attachments

Power regeneration converter unit	Attachment for power regeneration converter units	Drive unit	Attachment for drive units
MR-CV11K4 MR-CV18K4	MR-ADCACN090	MR-J5D1_ MR-J5D2_ MR-J5D3_	No attachment required
MR-CV30K4 MR-CV37K4 MR-CV45K4	MR-ADCACN150	MR-J5D1_ MR-J5D2-100G4 MR-J5D2-200G4 MR-J5D2-350G4 MR-J5D3_	MR-ADACN060
		MR-J5D2-500G4 MR-J5D2-700G4	MR-ADACN075
MR-CV55K4 MR-CV75K4	MR-ADCACN300	MR-J5D1_ MR-J5D2-100G4 MR-J5D2-200G4 MR-J5D2-350G4 MR-J5D3_	MR-ADACN060
		MR-J5D2-500G4 MR-J5D2-700G4	MR-ADACN075

Selection of attachment for power regeneration converter units

Mounting attachment installation procedure

The following shows how to install the mounting attachment to the power regeneration converter unit and then to the cabinet. It is also possible to install the mounting attachment to the cabinet first and then to the converter unit.

At the removal, it is possible to remove both the mounting attachment and the converter unit or the converter unit alone.

1. Attach the mounting attachment to the power regeneration converter unit.

- MR-CV11K4/MR-CV18K4

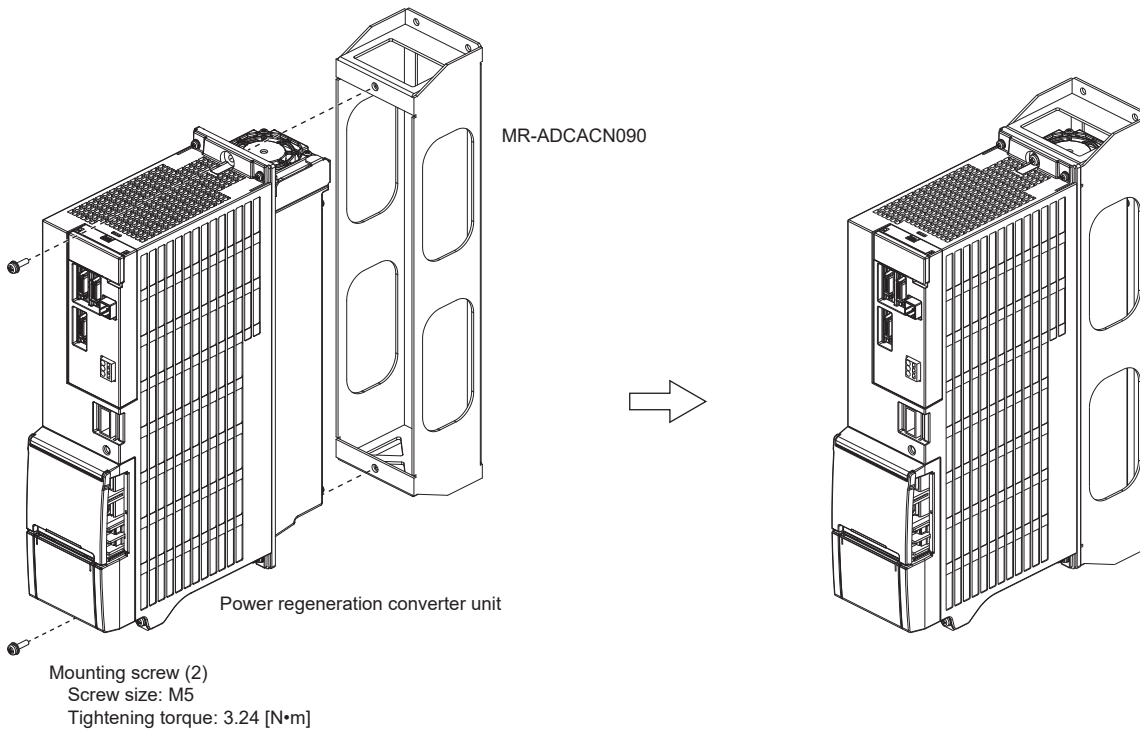

- MR-CV30K4/MR-CV37K4/MR-CV45K4/MR-CV55K4/MR-CV75K4

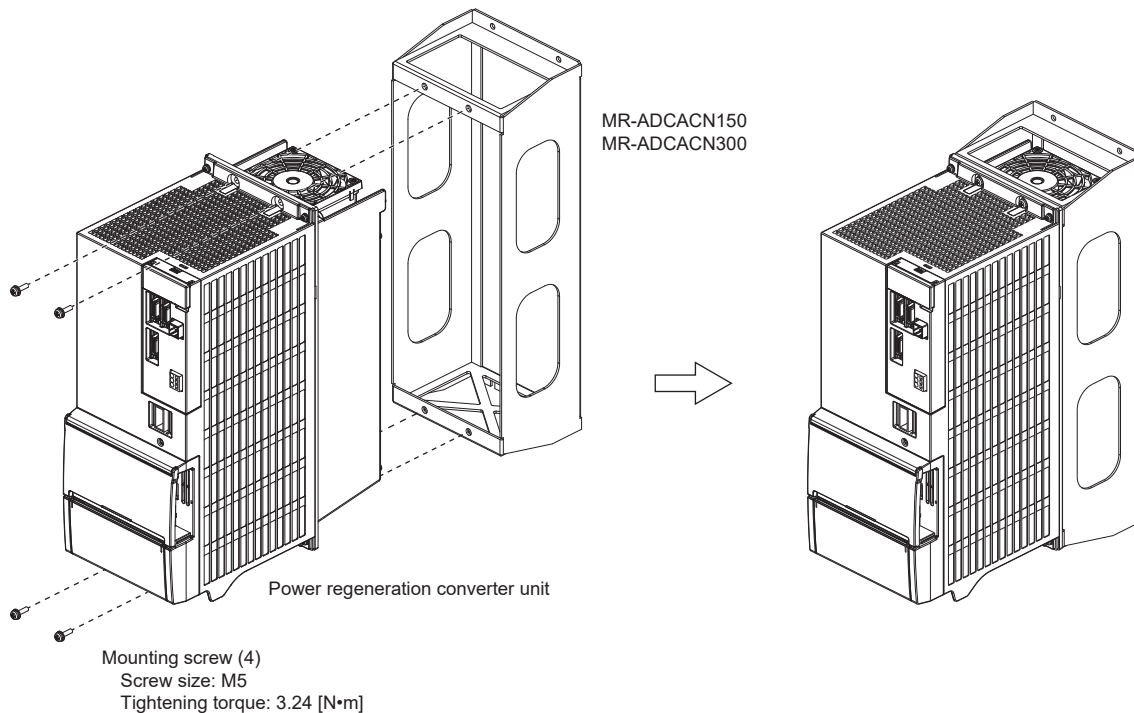

2. Install the power regeneration converter unit to the cabinet.

- MR-CV11K4/MR-CV18K4

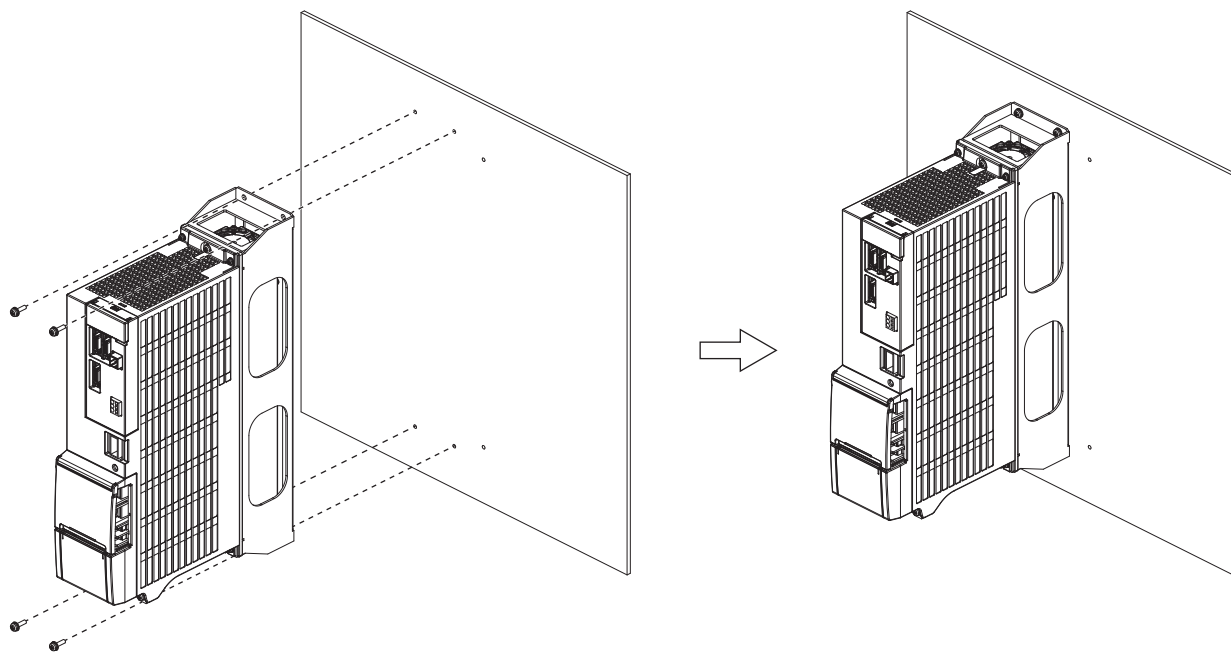

Mounting screw (4)
Screw size: M5
Tightening torque: 3.24 [N·m]

- MR-CV30K4/MR-CV37K4/MR-CV45K4/MR-CV55K4/MR-CV75K4

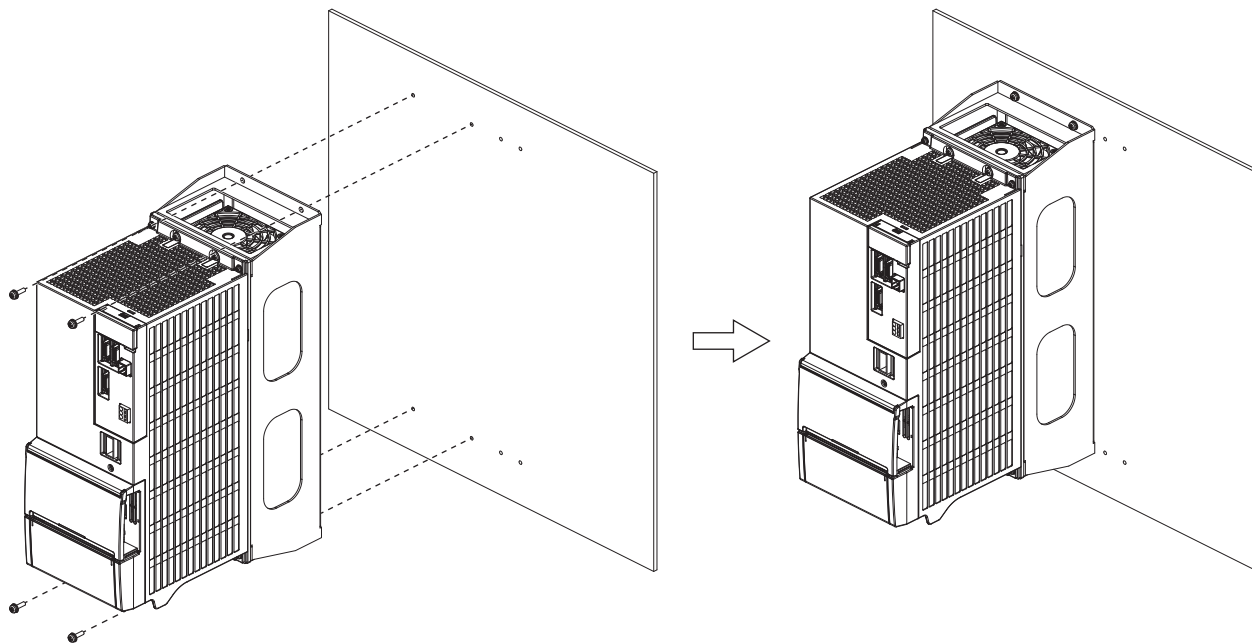

Mounting screw (4)
Screw size: M5
Tightening torque: 3.24 [N·m]

Selecting the attachment for drive units

Mounting attachment installation procedure

The following shows how to install the mounting attachment to the drive unit and then to the cabinet.

It is also possible to install the mounting attachment to the cabinet first and then to the drive unit.

At the removal, it is possible to remove both the mounting attachment and the drive unit or the drive unit alone.

1. Install the mounting attachment to the drive unit.

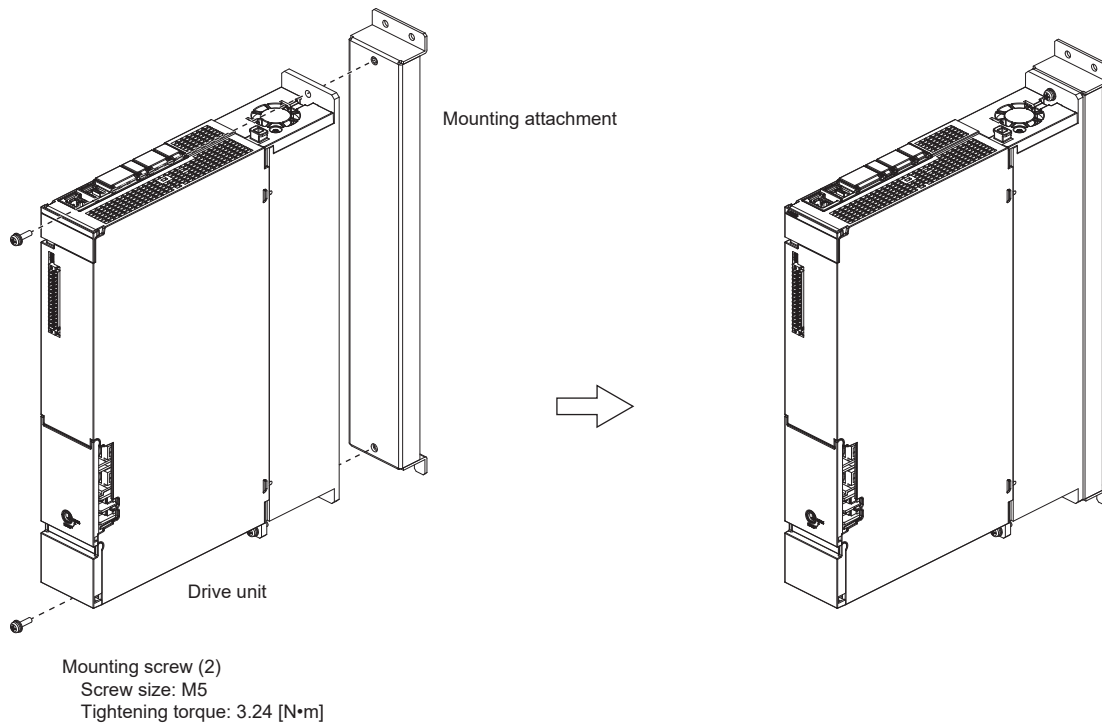

2. Install the drive unit to the cabinet.

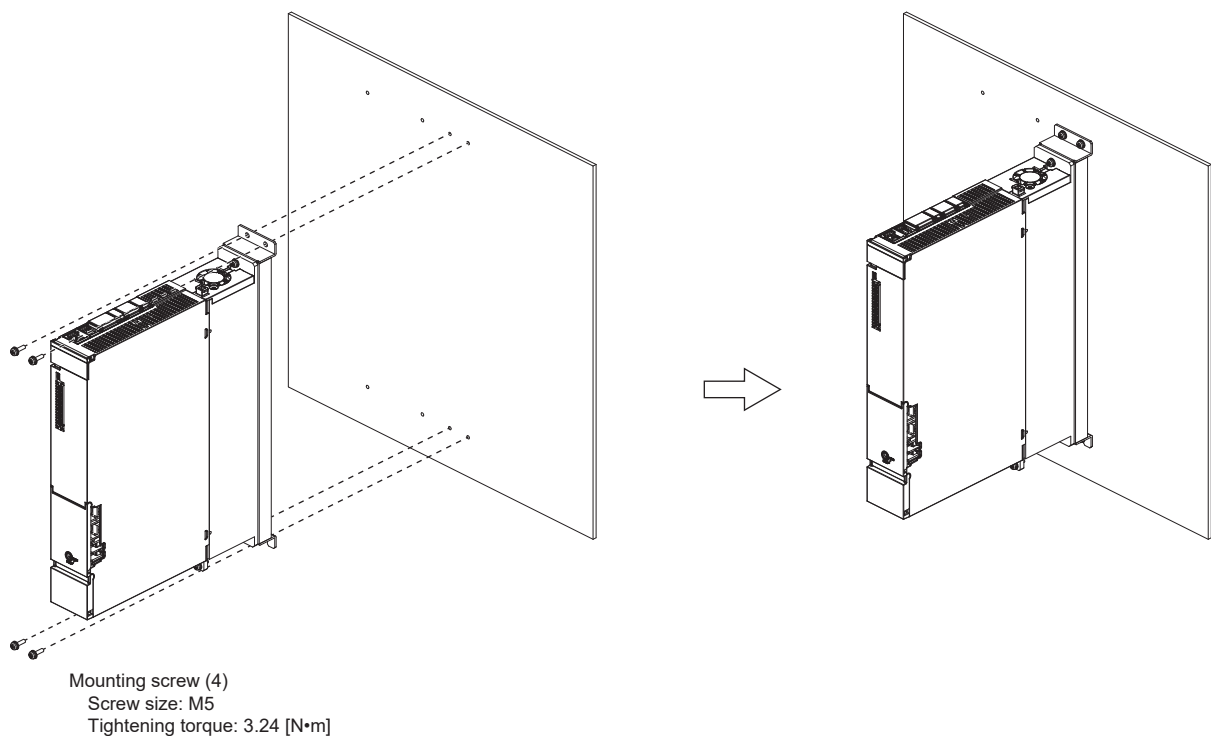

Dimensions when installing the mounting attachment

Power regeneration converter unit

■MR-CV11K4/MR-CV18K4

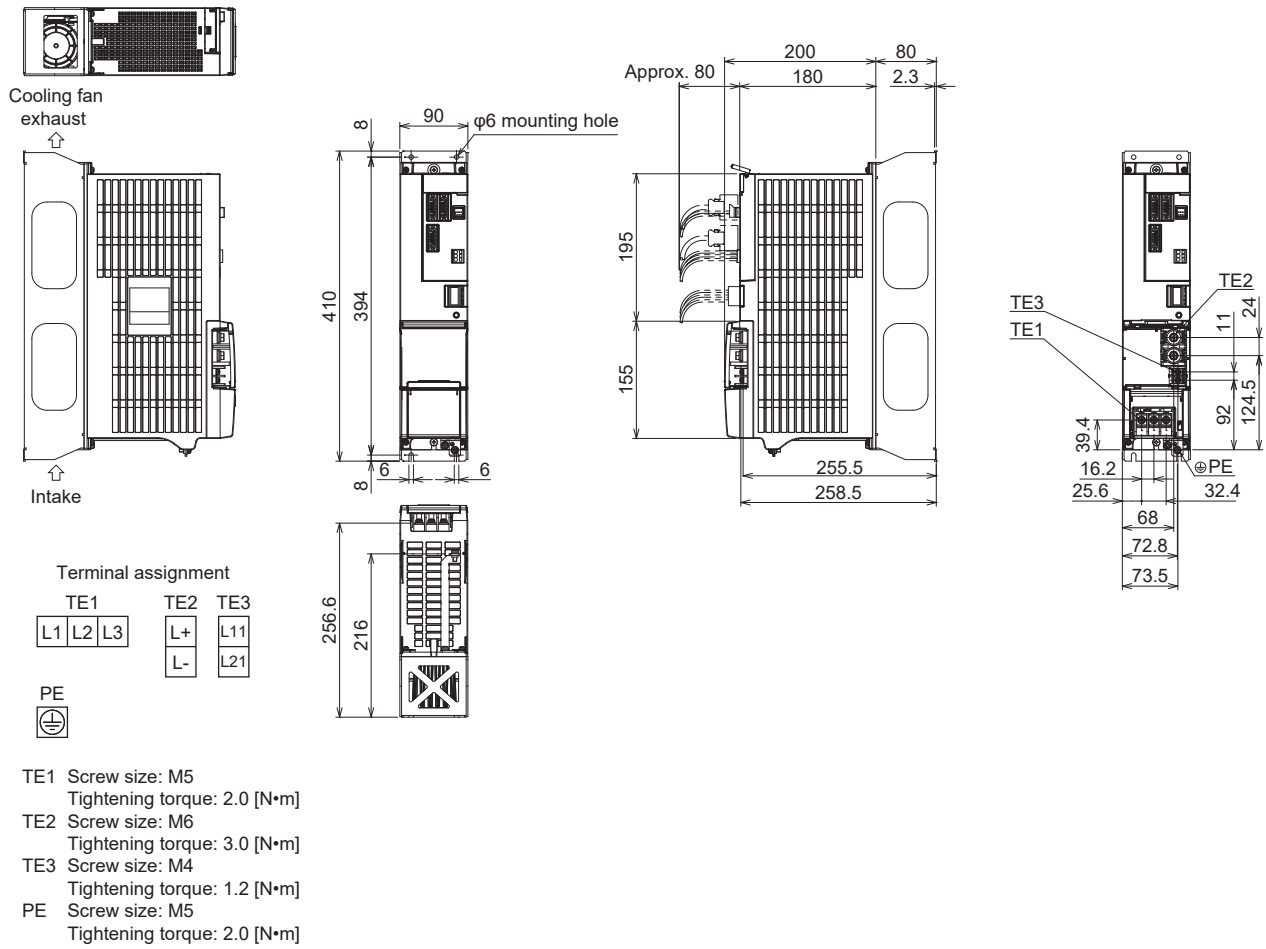

■MR-CV30K4/MR-CV37K4/MR-CV45K4

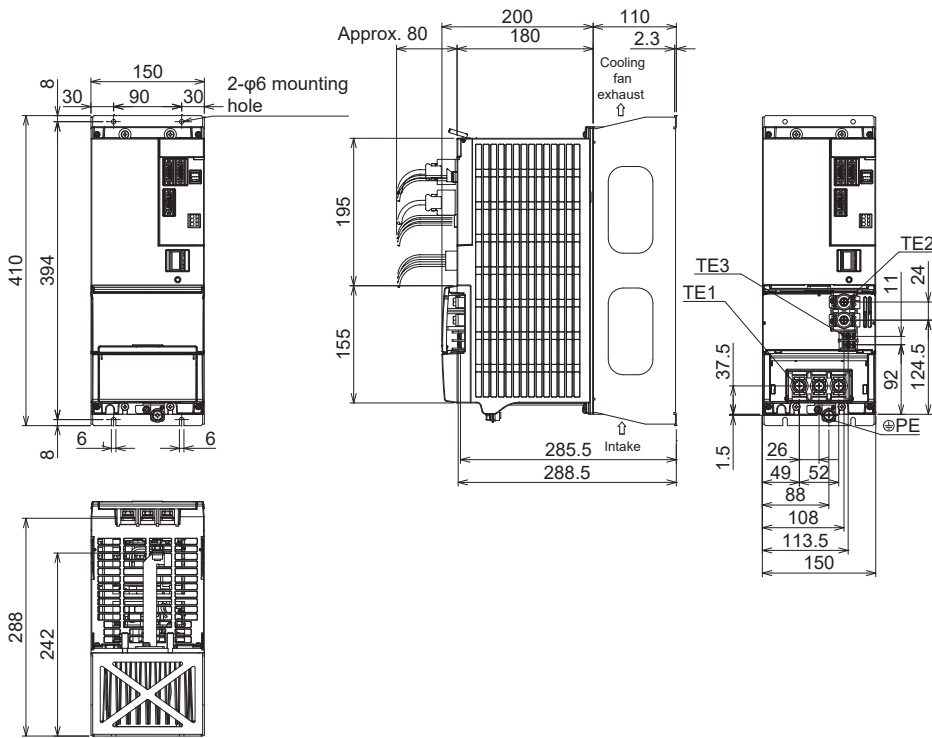

Terminal assignment

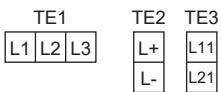

- TE1 Screw size: M8
Tightening torque: 6.0 [N•m]
- TE2 Screw size: M6
Tightening torque: 3.0 [N•m]
- TE3 Screw size: M4
Tightening torque: 1.2 [N•m]
- PE Screw size: M8
Tightening torque: 6.0 [N•m]

■MR-CV55K4/MR-CV75K4

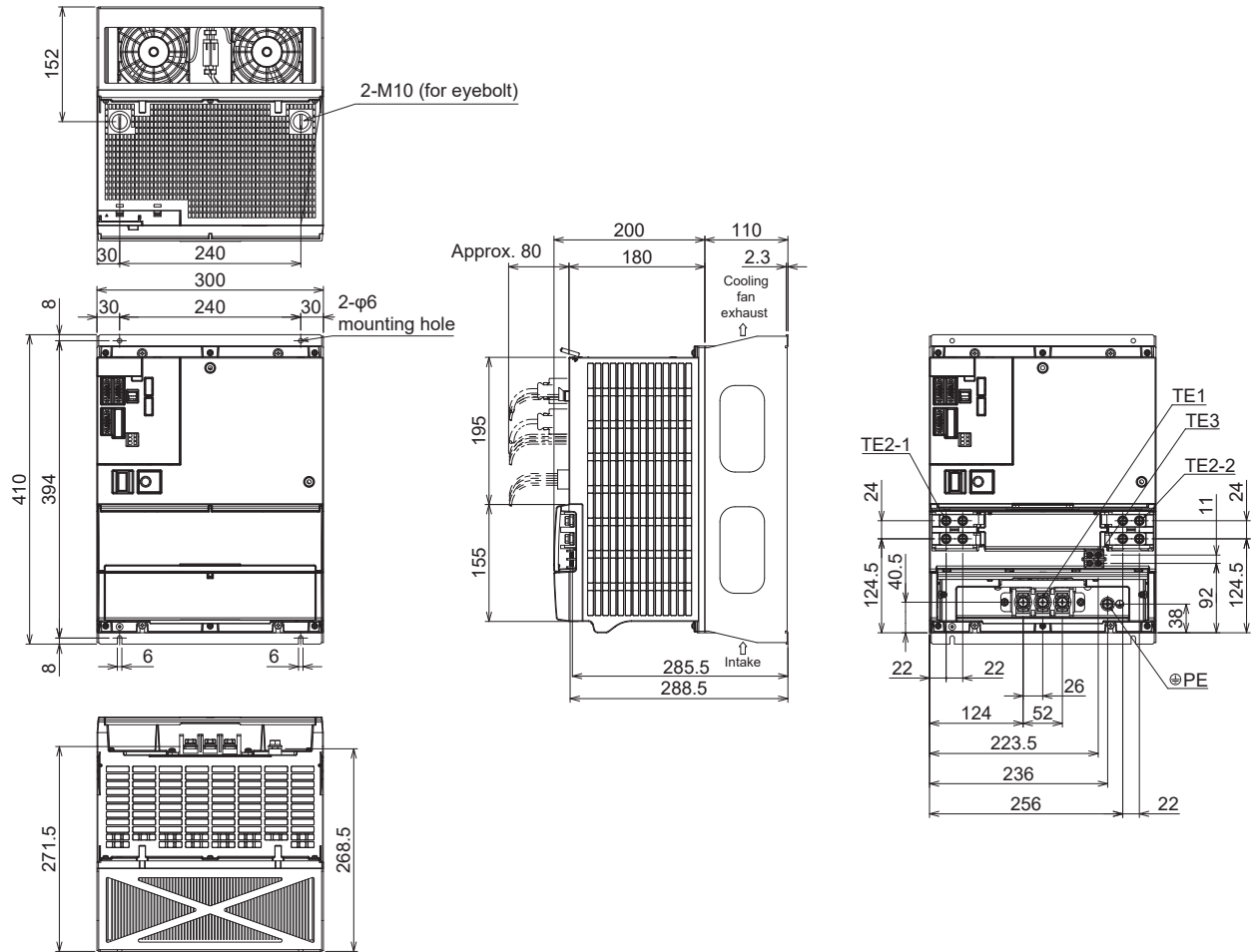

Terminal assignment

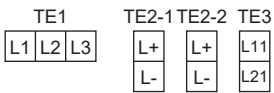

- TE1 Screw size: M8
Tightening torque: 6.0 [N•m]
- TE2-1 Screw size: M6
Tightening torque: 3.0 [N•m]
- TE2-2 Screw size: M6
Tightening torque: 3.0 [N•m]
- TE3 Screw size: M4
Tightening torque: 1.2 [N•m]
- PE Screw size: M8
Tightening torque: 6.0 [N•m]

Drive unit

MR-J5D1-100G4 to MR-J5D1-350G4

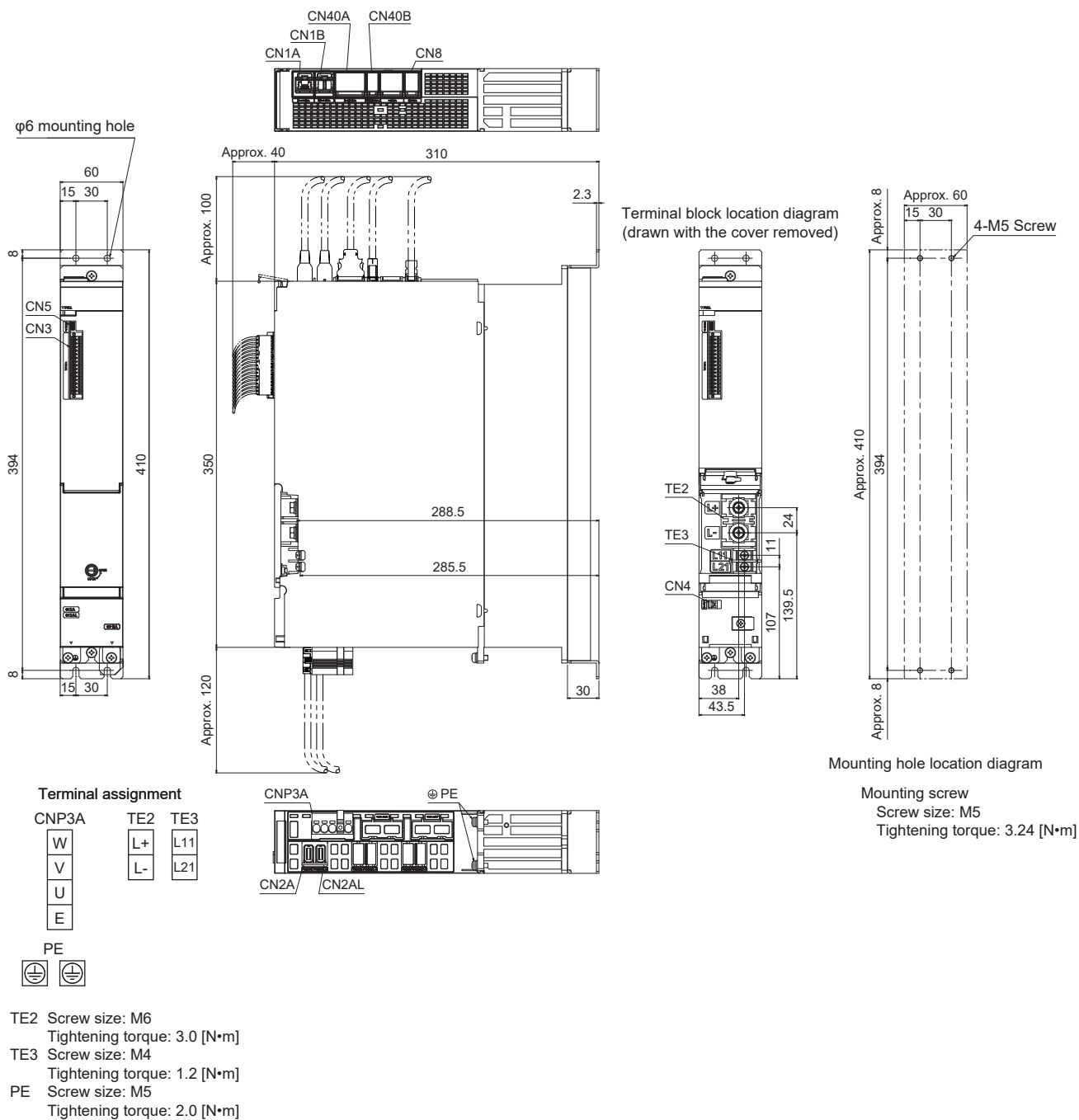

MR-J5D1-500G4/MR-J5D1-700G4

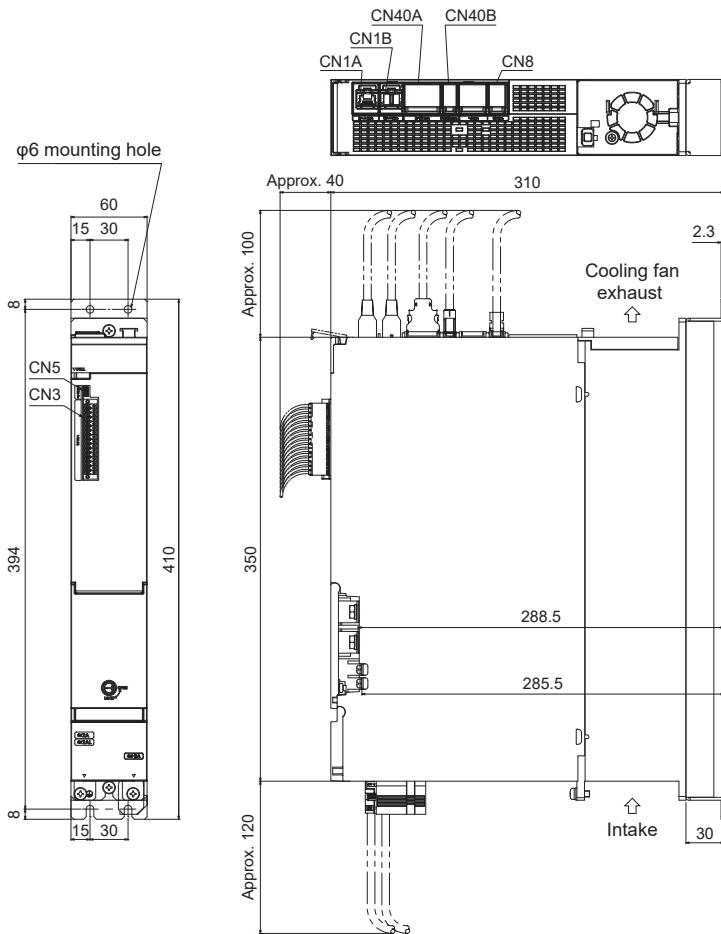

Terminal block location diagram (drawn with the cover removed)

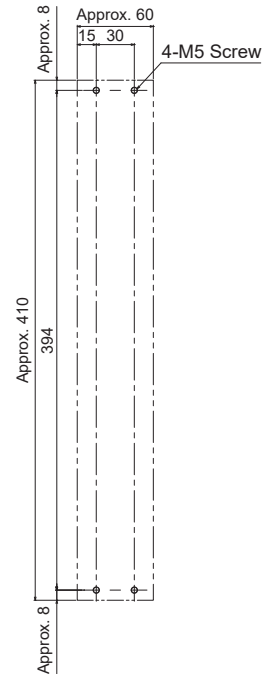
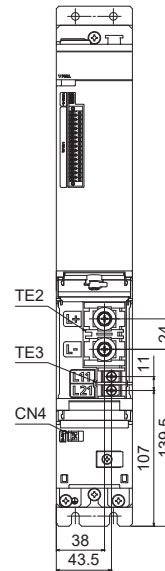

Mounting hole location diagram

Terminal assignment

CNP3A	TE2	TE3
W	L+	L11
V	L-	L21
U		
E		

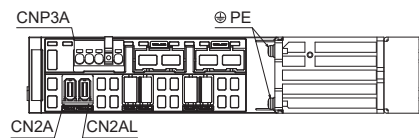

Mounting screw
Screw size: M5
Tightening torque: 3.24 [N•m]

- TE2 Screw size: M6
Tightening torque: 3.0 [N•m]
- TE3 Screw size: M4
Tightening torque: 1.2 [N•m]
- PE Screw size: M5
Tightening torque: 2.0 [N•m]

MR-J5D2-100G4

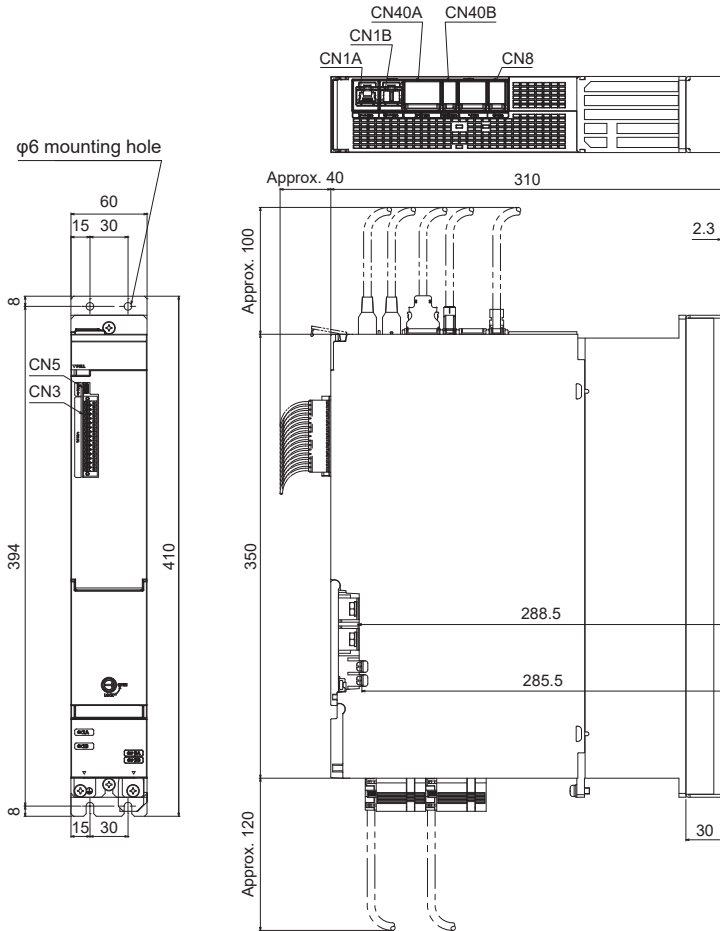

Terminal block location diagram (drawn with the cover removed)

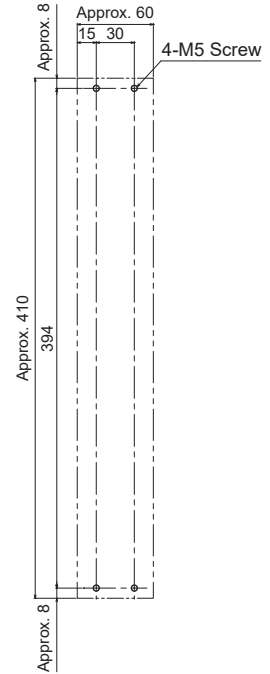
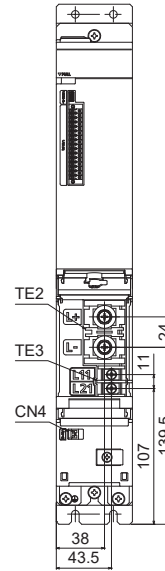

Mounting hole location diagram

Mounting screw
Screw size: M5
Tightening torque: 3.24 [N•m]

Terminal assignment

CNP3A/CNP3B	TE2	TE3
W	L+	L11
V	L-	L21
U		
E		

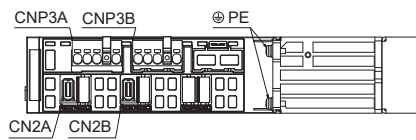

- TE2 Screw size: M6
Tightening torque: 3.0 [N•m]
- TE3 Screw size: M4
Tightening torque: 1.2 [N•m]
- PE Screw size: M5
Tightening torque: 2.0 [N•m]

MR-J5D2-200G4/MR-J5D2-350G4

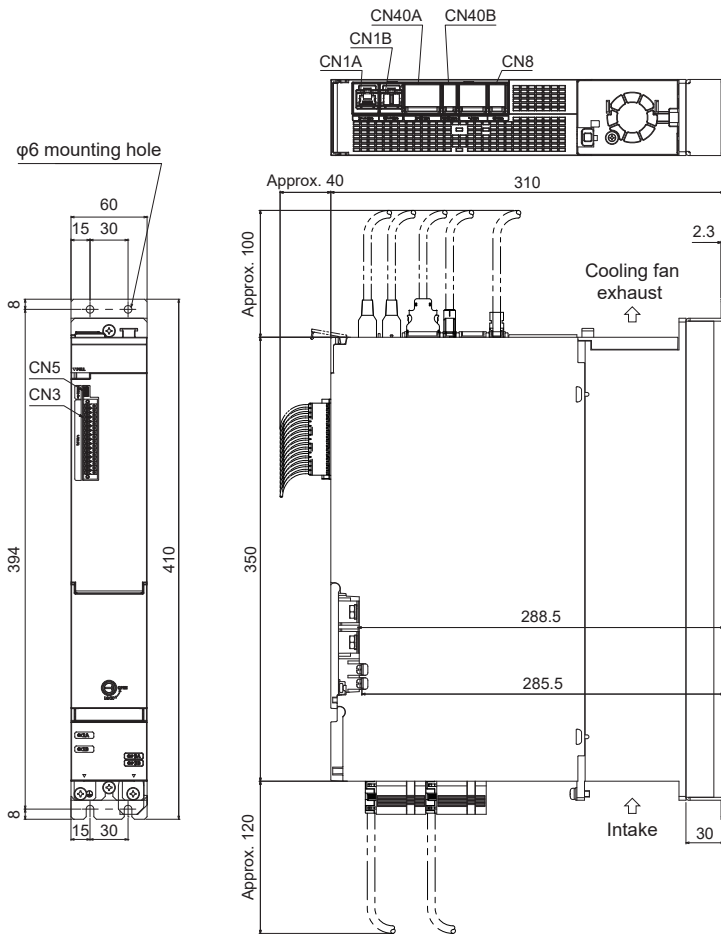

Terminal block location diagram (drawn with the cover removed)

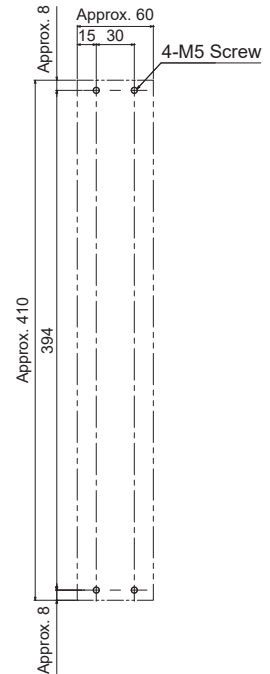
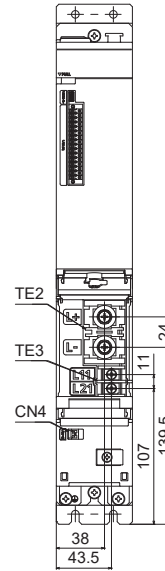

Mounting hole location diagram

Mounting screw
Screw size: M5
Tightening torque: 3.24 [N•m]

Terminal assignment

CNP3A/CNP3B	TE2	TE3
W	L+	L11
V	L-	L21
U		
E		

PE

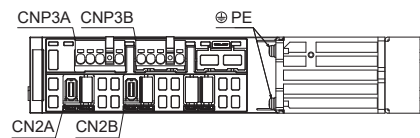

- TE2 Screw size: M6
Tightening torque: 3.0 [N•m]
- TE3 Screw size: M4
Tightening torque: 1.2 [N•m]
- PE Screw size: M5
Tightening torque: 2.0 [N•m]

MR-J5D2-500G4/MR-J5D2-700G4

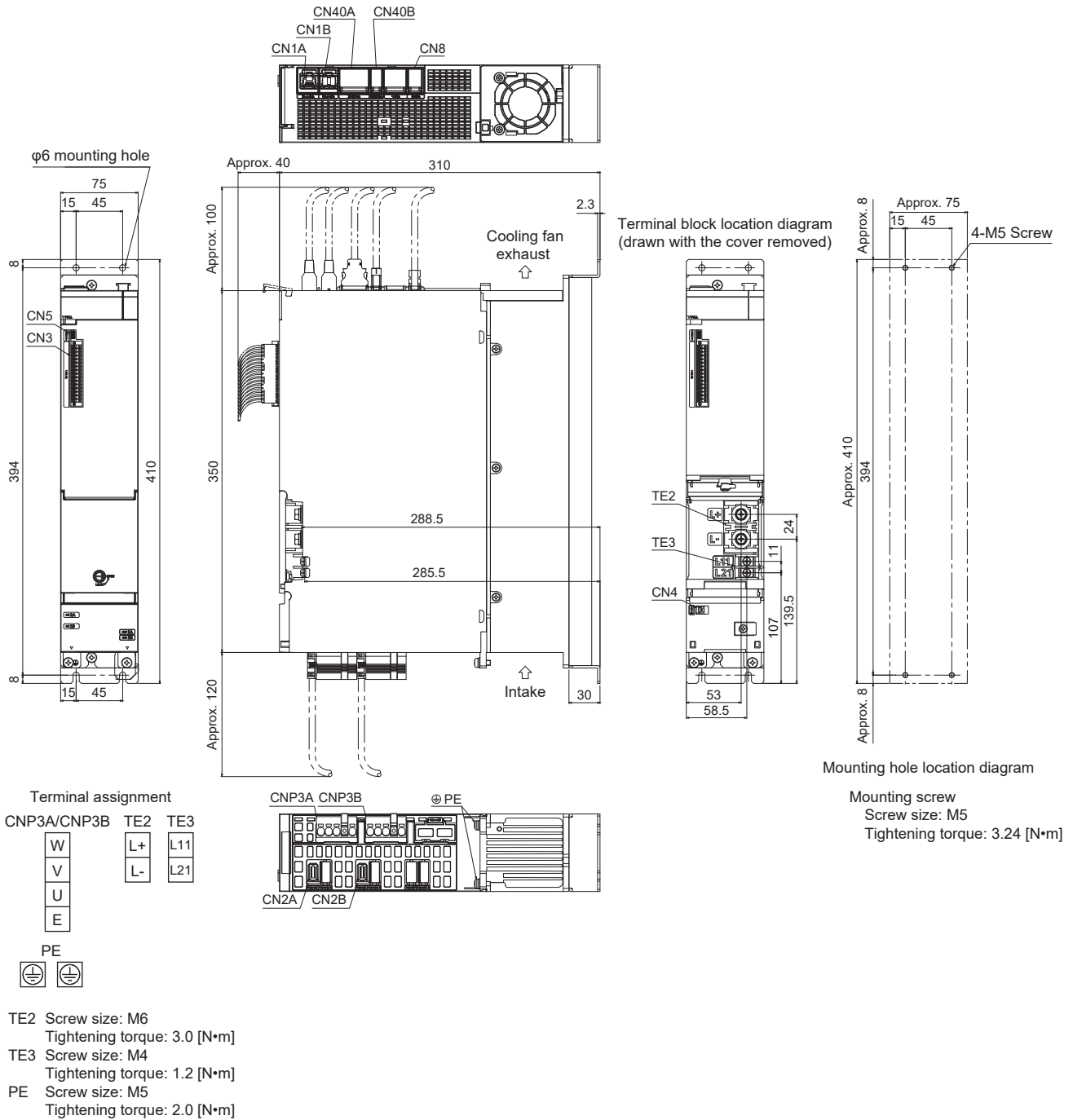

■MR-J5D3-100G4

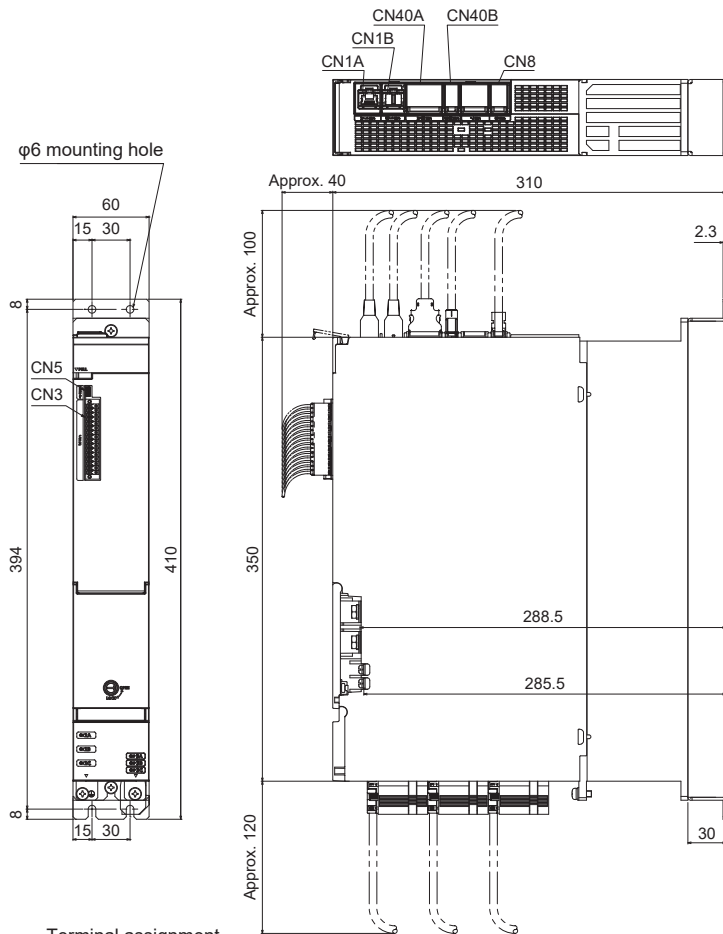

Terminal block location diagram (drawn with the cover removed)

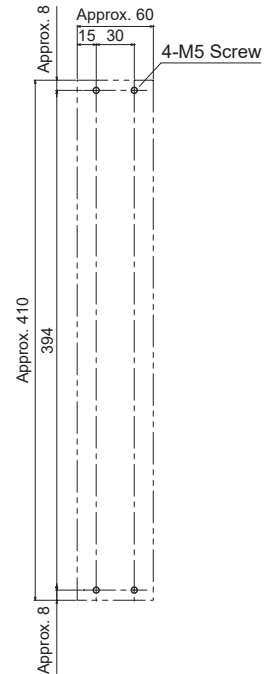
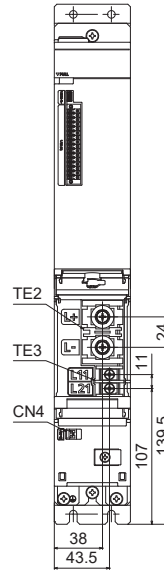

Mounting hole location diagram

Mounting screw
Screw size: M5
Tightening torque: 3.24 [N•m]

Terminal assignment

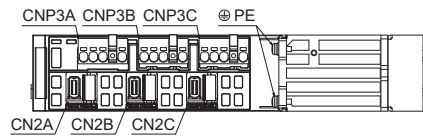
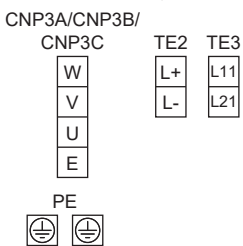

- TE2 Screw size: M6
Tightening torque: 3.0 [N•m]
- TE3 Screw size: M4
Tightening torque: 1.2 [N•m]
- PE Screw size: M5
Tightening torque: 2.0 [N•m]

MR-J5D3-200G4

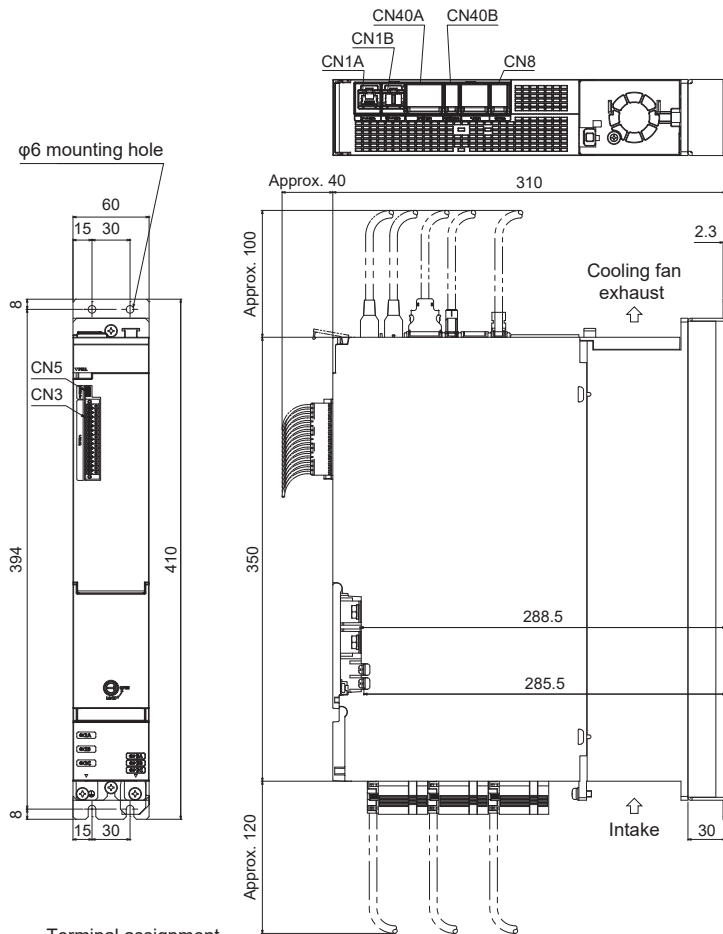

Terminal block location diagram (drawn with the cover removed)

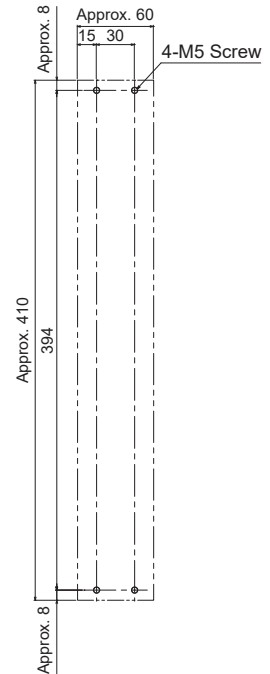
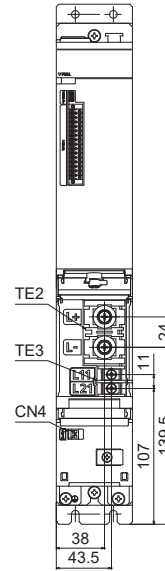

Mounting hole location diagram

Mounting screw
Screw size: M5
Tightening torque: 3.24 [N•m]

Terminal assignment

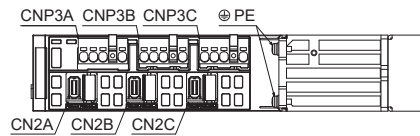
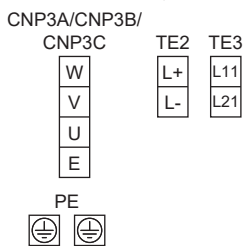

- TE2 Screw size: M6
Tightening torque: 3.0 [N•m]
- TE3 Screw size: M4
Tightening torque: 1.2 [N•m]
- PE Screw size: M5
Tightening torque: 2.0 [N•m]

3 SIGNALS AND WIRING

Precautions

- Insulate the conductive parts of the terminals.
- Turn off the power and wait for 20 minutes or more until the charge light of the unit turns off. Checking the voltage between L+ and L- using the tester, etc. is recommended.
- If using a regenerative resistor, configure a circuit that shuts off the main circuit power supply with an alarm signal because abnormal overheating of the regenerative resistor may cause smoke and fire.
- To prevent failure and malfunction, only the power supply/signal specified in the user's manual should be connected to a corresponding terminal.
- To prevent unexpected operation of the servo motor, wire the equipment correctly and securely.
- Make sure to connect the cables and connectors by using the fixing screws and the locking mechanism. Failing to do so may cause the cables and connectors to disconnect during operation.
- Unless stated otherwise, all connection diagrams in this user's manual are sink interface diagrams.
- Install a surge absorbing diode in the correct direction. Failing to do so may cause the amplifier to malfunction and not to output signals, disabling protective circuits such as the emergency stop.

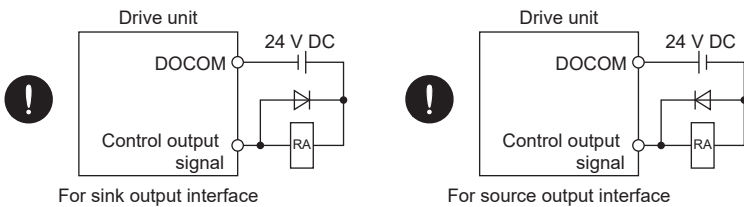

- If the wires are not properly secured to the terminal block, the poor contact may cause the wires and terminal block to generate heat. Be sure to secure the wires with the specified torque.
- Connecting the servo motor for an incorrect axis to the power outputs (U/V/W) or CN2_ of the drive unit may cause a malfunction.
- Check that no operation signal is being input to the drive unit before resetting an alarm or releasing the emergency stop. Failing to do so may cause an unexpected operation.
- If the power supply is shut off by a molded-case circuit breaker or a fuse, remove the cause and secure safety before switching the power on.
- Install the drive unit according to the EMC guidelines because electromagnetic interference may affect the electronic equipment used near the drive unit.
- To prevent an electric shock or a fire, do not disassemble, repair, or modify the product. Disassembled, repaired, and/or modified products are not covered under warranty.
- Eliminate static electricity before performing actions such as wiring or operating a switch.

3.1 Example power circuit connections

Precautions

- Connect a magnetic contactor between a power supply and the main circuit power supply (L1/L2/L3) of a converter unit to configure a circuit that shuts off the power supply on the converter unit side because failure of the converter unit may cause smoke and fire if a magnetic contactor is not connected.
- Use a configuration that shuts off the main circuit power supply with ALM (Malfunction).
- Check the converter unit model and use the correct power supply voltage.
- Exogenous noise or lightning surges may degrade the characteristics of the surge absorber (varistor) built into the converter unit and damage it.
- Do not shut off the control circuit power supply even if an alarm occurs. If the control circuit power supply is shut off, network communication will be interrupted.
- In the torque mode, EM2 functions the same as EM1.
- To prevent malfunction, avoid bundling the converter unit/drive unit's power lines (input/output) and signal cables together or running them parallel to each other. Separate the power lines from the signal cables.
- Provide adequate protection to prevent an unexpected restart after an instantaneous power failure.
- Configure wiring so that the main circuit power supply is shut off and the servo-on command is turned off after deceleration to a stop due to an alarm occurrence, an enabled servo forced stop, or a quick stop command from the controller. Use a molded-case circuit breaker (MCCB) with the input cables of the main circuit power supply.

Drive unit termination settings

Set [Pr. PC46.2] and [Pr. PC46.3] in each drive unit as follows according to the configuration of the converter unit and drive unit.

Number of drive units connected to one converter unit	Drive unit position	Servo parameter	
		[Pr. PC46.2 Protection coordination multiple connections selection]	[Pr. PC46.3 Protection coordination end terminal setting]
1	—	0 (initial value)	Setting disabled
2 or more	Far end	1	1
	Other than at the far end		0 (initial value)

When the magnetic contactor drive output is enabled



Set the converter setting rotary switch of the power regeneration converter unit to "0" (factory setting).

■ For crossover wiring of L11/L21

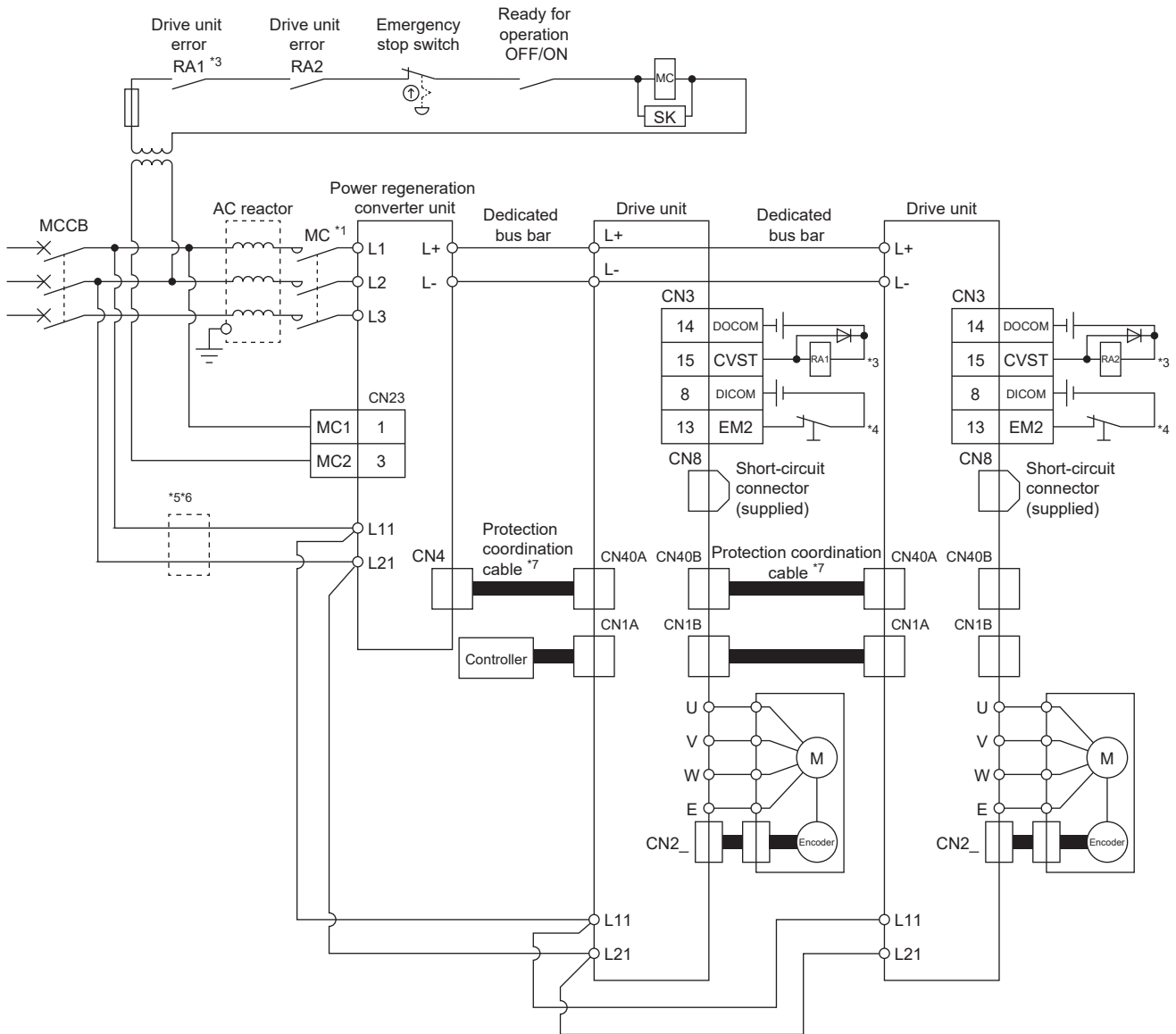

- *1 Use the magnetic contactor with an operation delay time (interval between current being applied to the coil until closure of contacts) of 80 ms or less. The bus voltage may drop depending on the main circuit power supply voltage and operation pattern, causing a dynamic brake deceleration during a forced stop deceleration.
- *2 To prevent an unexpected restart of the drive unit, configure a circuit that turns off EM2 of the drive unit when the main circuit power supply is turned off.
- *3 Use a configuration that shuts off the main circuit power supply by turning off CVST (converter stop). Assign CVST with [Pr. PD07 Output device selection 1].
- *4 When performing forced stop deceleration using EM2, the converter unit shuts off the main circuit power supply by protection coordination after the servo motor stops.
- *5 Install an overcurrent protection device (molded-case circuit breaker, fuse, etc.) to protect the branch circuit.
 Page 123 Molded-case circuit breakers, fuses
- *6 For wire size and overcurrent protection device selection, refer to the following.
 Page 121 Selection example of wires
- *7 Use the MR-ACDL_M for the protection coordination cable between the converter unit and the drive unit. Use the MR-ADDL02M for the protection coordination cable between drive units.

■ For branch wiring of L11/L21

For notes, refer to the notes in the following section.

☞ Page 43 For crossover wiring of L11/L21

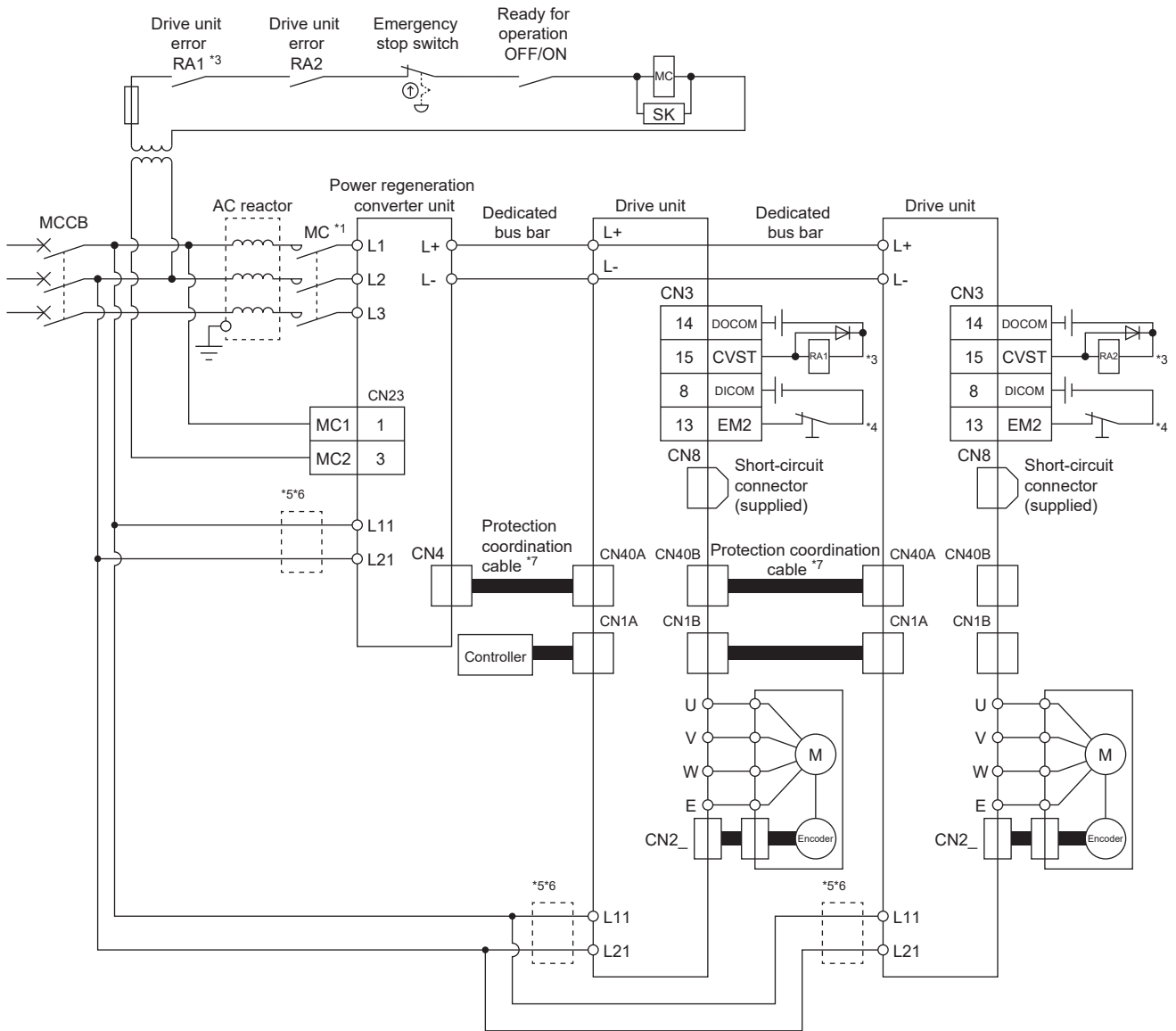

When the magnetic contactor drive output is disabled



Set the converter setting rotary switch of the power regeneration converter unit to "1".

■ For crossover wiring of L11/L21

For notes, refer to the notes in the following section.

☞ Page 43 For crossover wiring of L11/L21

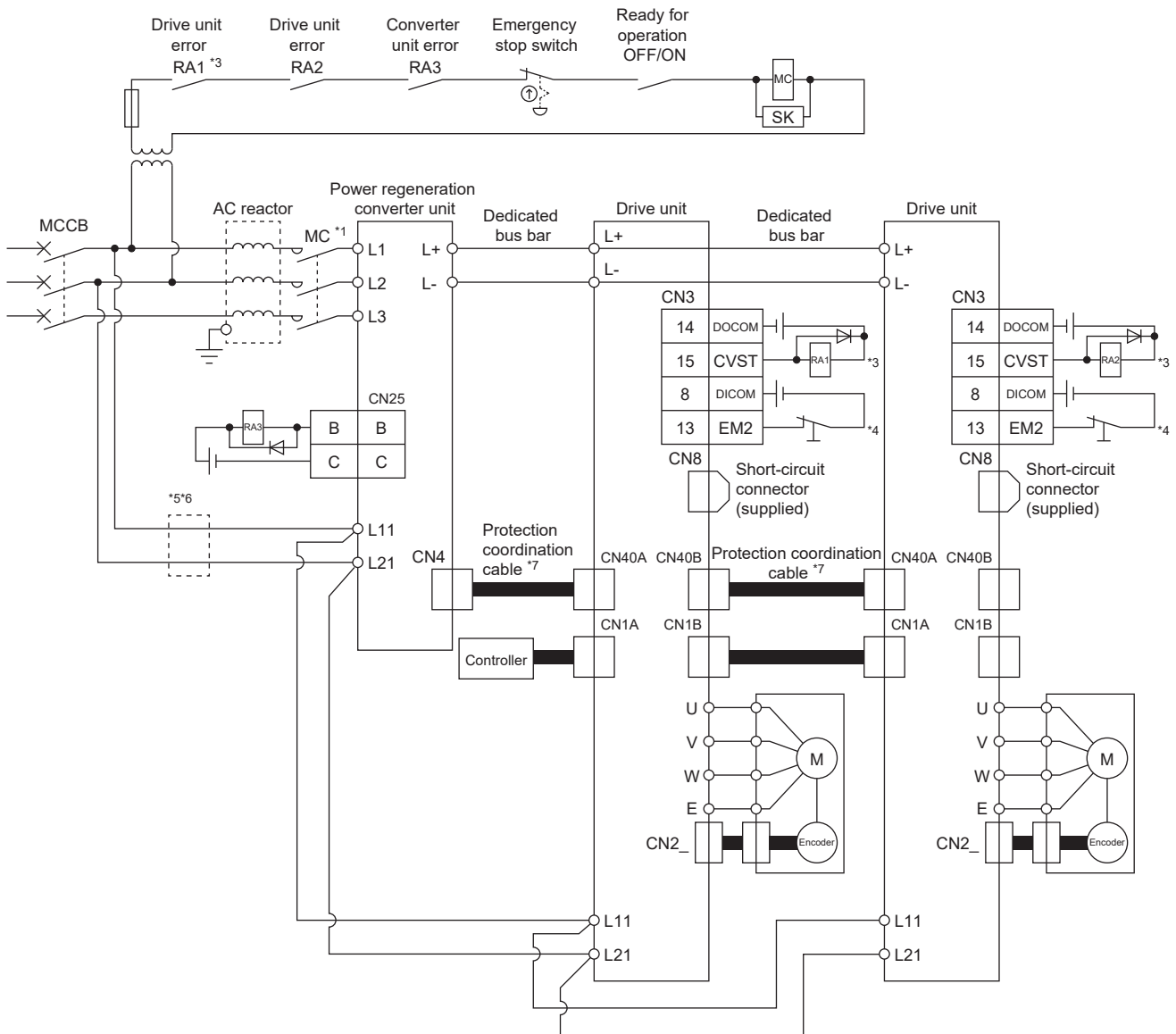

■ For branch wiring of L11/L21

For notes, refer to the notes in the following section.

☞ Page 43 For crossover wiring of L11/L21

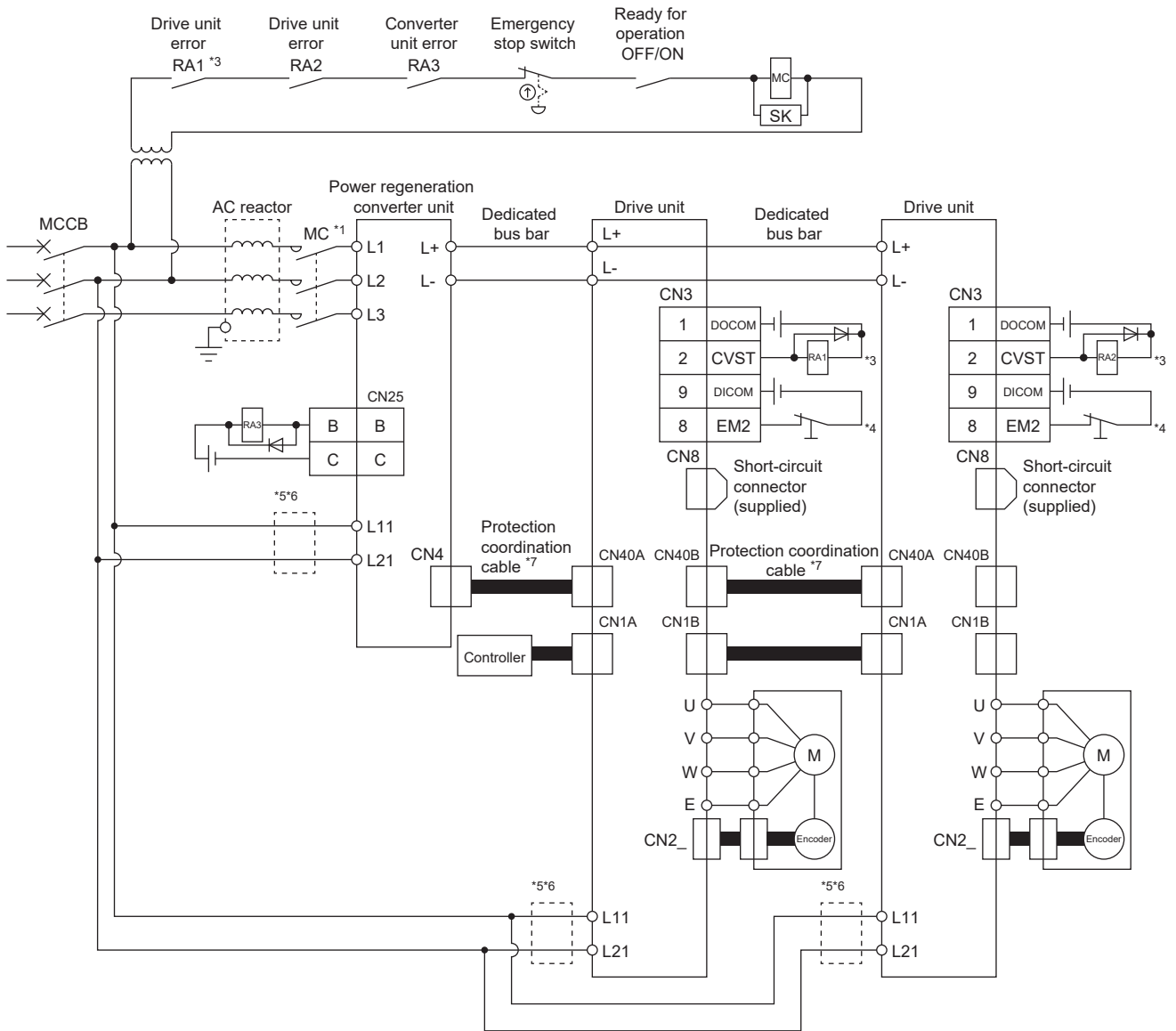

How to use the bus bar

Point

- Screw the top and bottom bus bar alternately starting from the converter unit side.
- Overlap and screw the bus bar on the TE2 terminal block of the drive unit.
- If the number of drive units connected to the converter unit is an even number, there will be a gap between the TE2 terminal block of the drive unit at the far end and the bus bar by the thickness of the conductor. Insert the adjustment bar (MR-DCBAR024-B05) between the TE2 terminal block and the bus bar and screw it in.

☞ Page 119 Adjustment bar

Connect L+ and L- of the converter unit and L+ and L- of the drive unit using the dedicated bus bar as follows. The figure is drawn with the terminal cover removed.

When connecting multiple drive units to the converter unit, arrange them in descending order of capacity per axis of the drive unit from the right side of the converter unit.

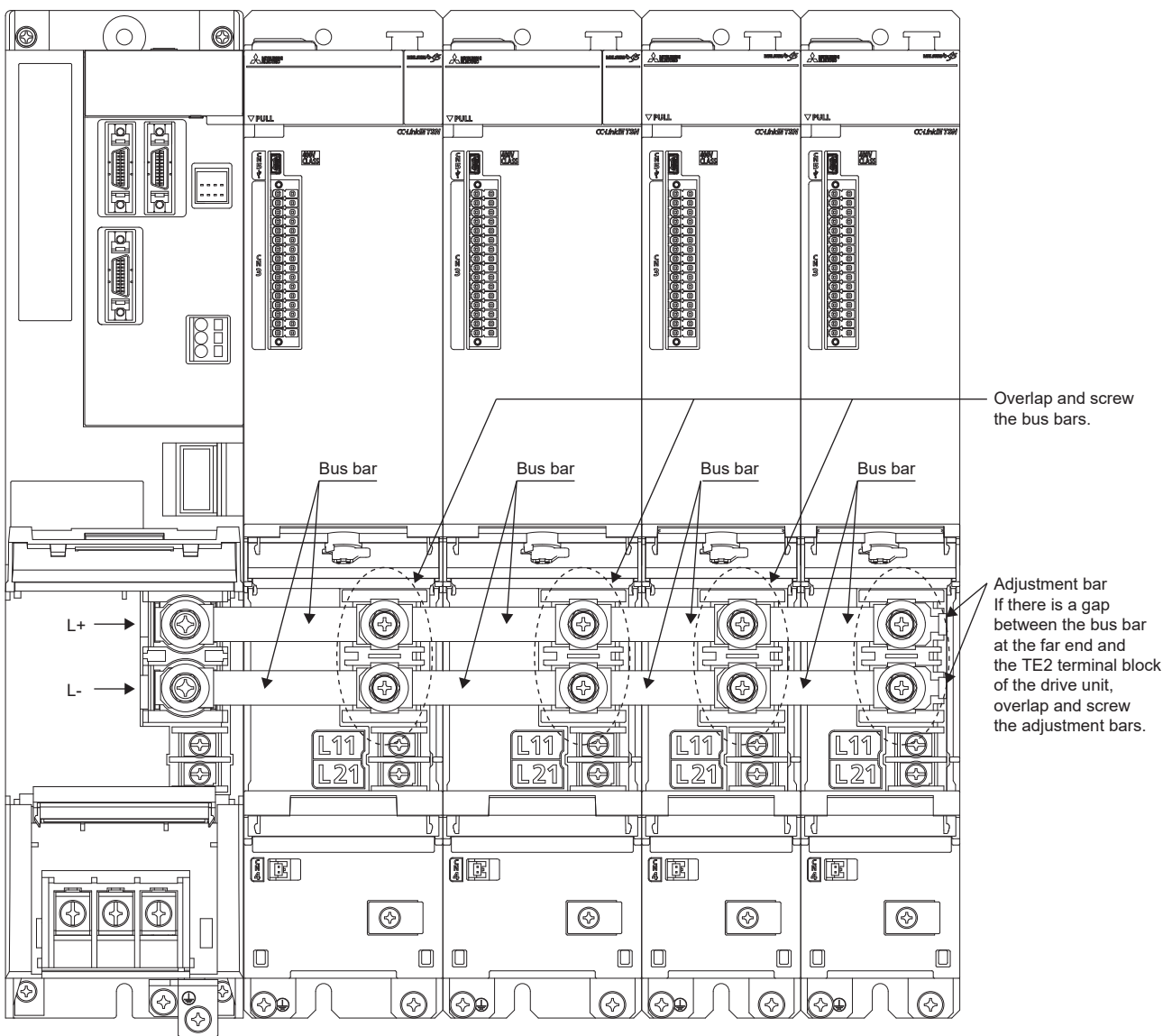

3.2 Example I/O signal connections

Precautions

- Do not connect CN1A and CN1B connectors to a network other than the network used by this drive unit. Doing so may cause a malfunction.
- In the torque mode, EM2 functions the same as EM1.

Sink I/O interface

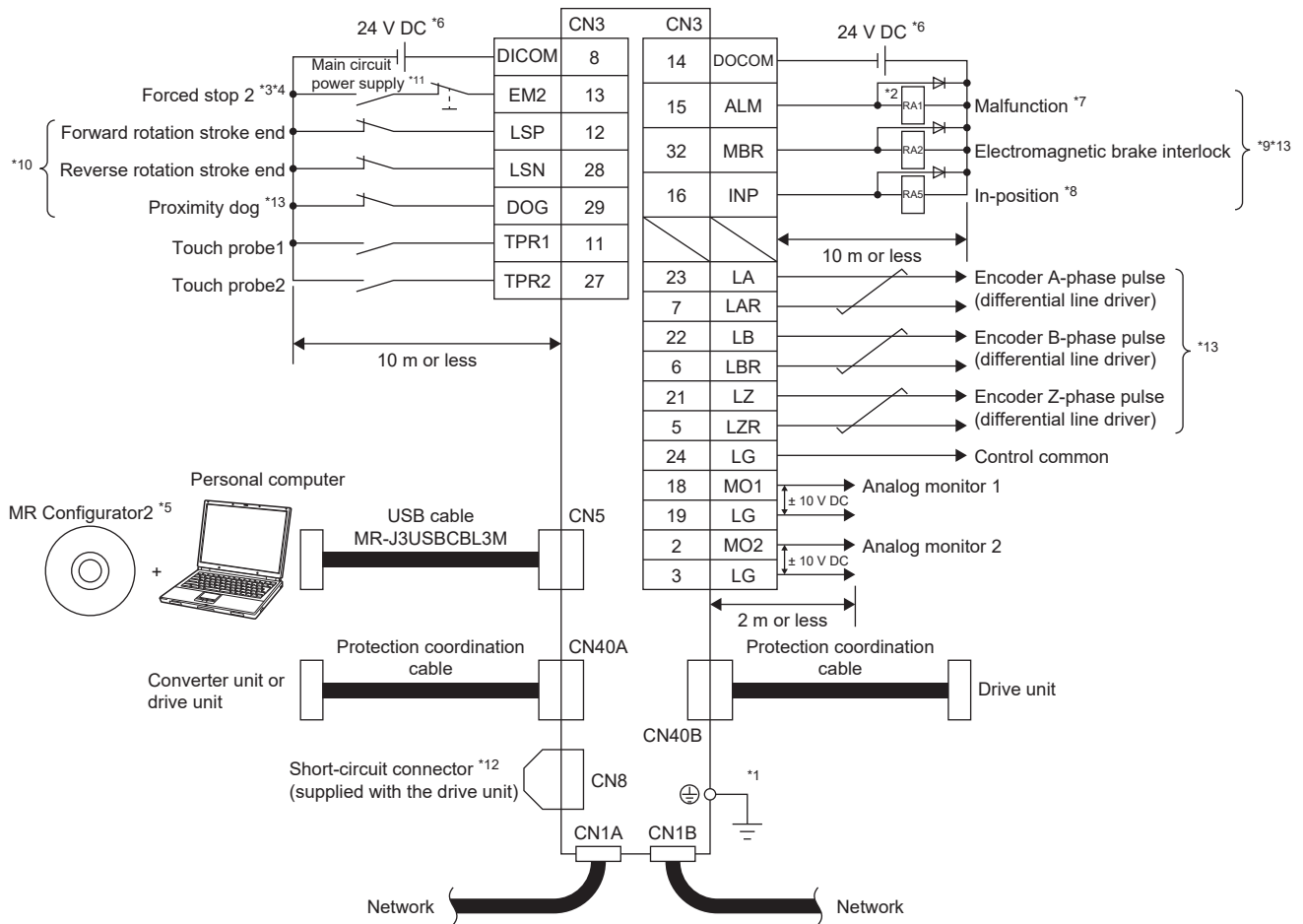

- *1 To prevent an electric shock, connect the protective earth (PE) terminal (the terminal marked with the \oplus symbol) of the drive unit to the protective earth (PE) of the cabinet.
- *2 Connect the diode in the correct direction. If it is connected reversely, the drive unit may malfunction and not output signals, disabling protective circuits such as EM2 (Forced stop 2).
- *3 If the controller does not have the forced stop function, install a forced stop 2 switch (normally closed contact).
- *4 When starting operation, turn on EM2 (Forced stop 2), LSP (Forward rotation stroke end), and LSN (Reverse rotation stroke end) (normally closed contact). If FLS (Upper stroke limit) and RLS (Lower stroke limit) are used via a controller, wiring LSP and LSN is unnecessary. In that case, set [Pr. PD41].
- *5 Use SW1DNC-MRC2-.
- *6 Supply 24 V DC \pm 10 % to interfaces from outside. The total current capacity of these power supplies is 300 mA maximum. The amperage will not exceed 300 mA when all I/O signals are used. Reducing the number of I/O points decreases the current capacity. For the amperage required for interfaces, refer to the following.
☞ Page 77 Digital input interface DI-1
 Although the diagram shows the input signal and the output signal each using a separate 24 V DC power supply for illustrative purposes, the system can be configured to use a single 24 V DC power supply.
- *7 If no alarm is occurring, ALM (Malfunction) is on (normally closed contact).
- *8 In the initial setting, INP (In-position) is assigned to this pin. The device of the pin can be changed with [Pr. PD08].
- *9 The devices of these pins can be changed with servo parameters ([Pr. PD07] to [Pr. PD09]).
- *10 The devices of these pins can be changed with servo parameters ([Pr. PD03] to [Pr. PD05]).
- *11 To prevent an unexpected restart of the drive unit, configure a circuit that turns off EM2 when the main circuit power supply is turned off.
- *12 If not using the STO function, attach the short-circuit connector that came with the drive unit.
- *13 This device can be changed to TPR3 (touch probe 3) by servo parameter settings. To set the device to TPR3, the wiring must be the same as TPR1 and TPR2.

Source I/O interface

For notes, refer to the notes in the following section.

☞ Page 49 Sink I/O interface

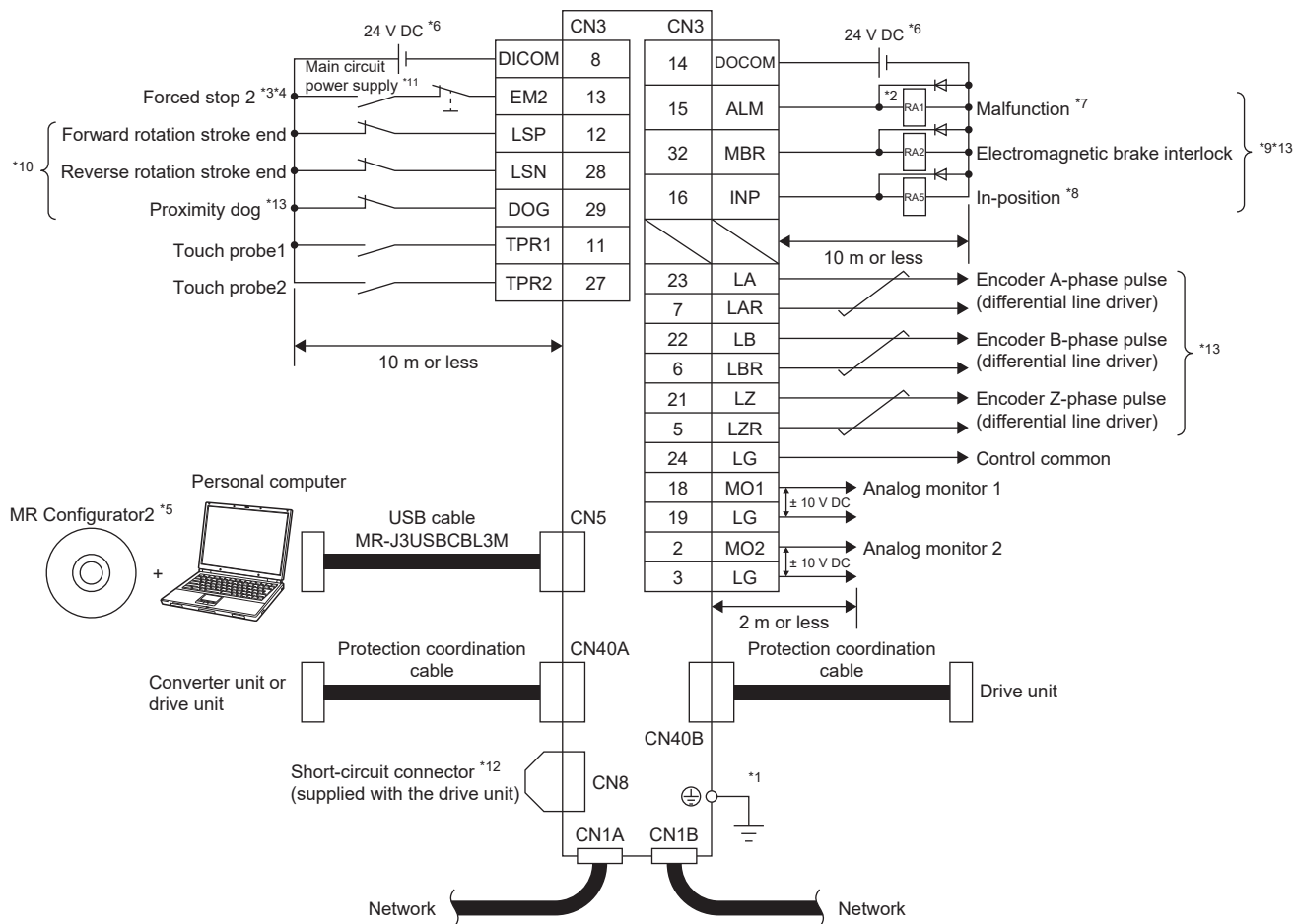

MR-J5D2-_G_/MR-J5D3-_G_

Sink I/O interface

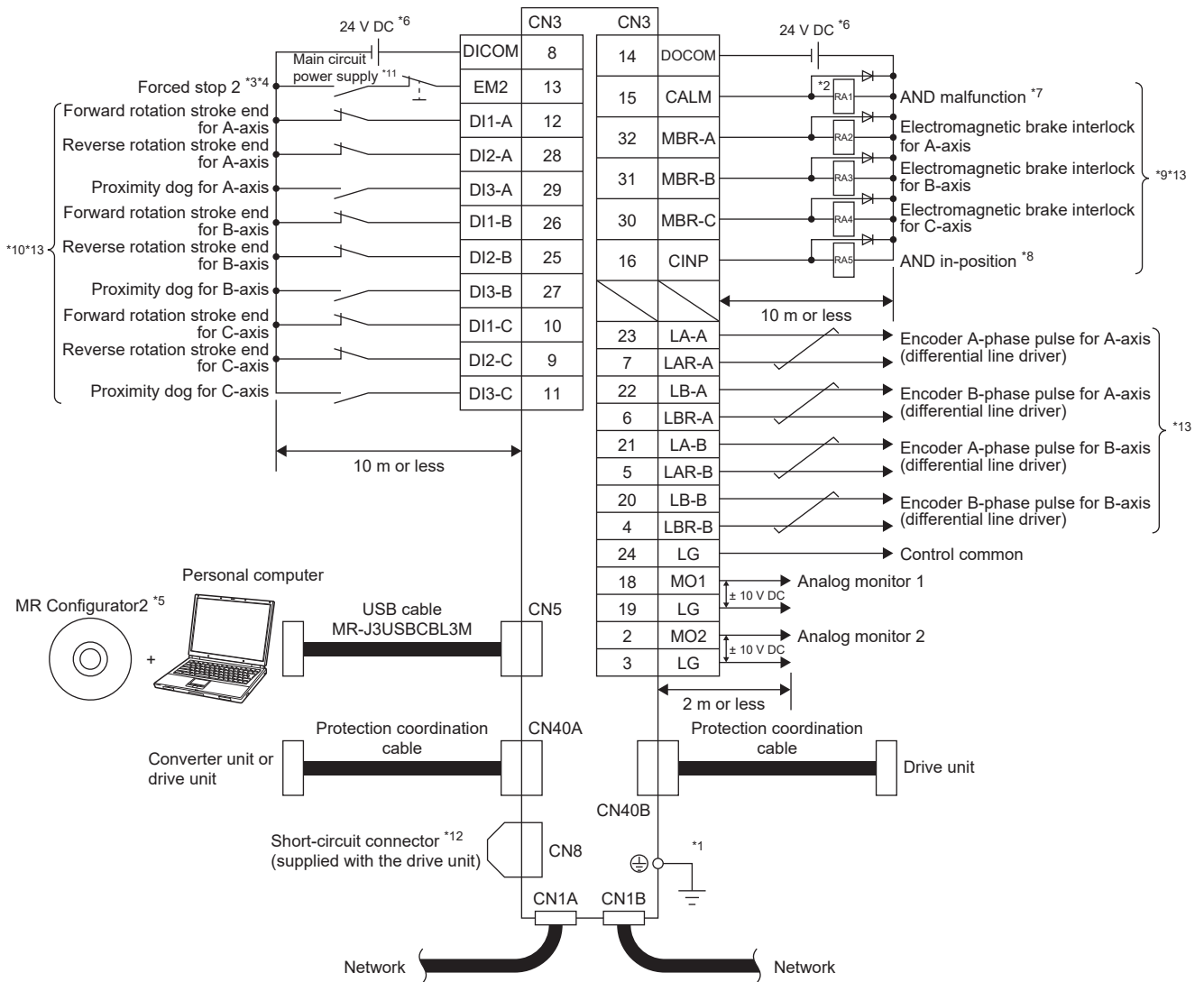

3

- *1 To prevent an electric shock, connect the protective earth (PE) terminal (the terminal marked with the \oplus symbol) of the drive unit to the protective earth (PE) of the cabinet.
- *2 Connect the diode in the correct direction. If it is connected reversely, the drive unit may malfunction and not output signals, disabling protective circuits such as EM2 (Forced stop 2).
- *3 If the controller does not have the forced stop function, install a forced stop 2 switch (normally closed contact).
- *4 When starting operation, turn on EM2 (Forced stop 2), LSP (Forward rotation stroke end), and LSN (Reverse rotation stroke end) (normally closed contact). If FLS (Upper stroke limit) and RLS (Lower stroke limit) are used via a controller, wiring LSP and LSN is unnecessary. In that case, set [Pr. PD41].
- *5 Use SW1DNC-MRC2-_-.
- *6 Supply 24 V DC \pm 10 % to interfaces from outside. The total current capacity of these power supplies is 350 mA maximum for the MR-J5D2-_G_ and 450 mA maximum for the MR-J5D3-_G_.
The amperage will not exceed 350 mA (MR-J5D2-_G_) and 450 mA (MR-J5D3-_G_) when all I/O signals are used. Reducing the number of I/O points decreases the current capacity. For the amperage required for interfaces, refer to the following.
 Page 77 Digital input interface DI-1
Although the diagram shows the input signal and the output signal each using a separate 24 V DC power supply for illustrative purposes, the system can be configured to use a single 24 V DC power supply.
- *7 If no alarm is occurring, CALM (AND malfunction) is on (normally closed contact).
- *8 In the initial setting, CINP (AND in-position) is assigned to this pin. The device of the pin can be changed with [Pr. PD08].
- *9 The devices of these pins can be changed with servo parameters ([Pr. PD07] to [Pr. PD09]).
- *10 The devices of these pins can be changed with servo parameters ([Pr. PD03] to [Pr. PD05]).
- *11 To prevent an unexpected restart of the drive unit, configure a circuit that turns off EM2 when the main circuit power supply is turned off.
- *12 If not using the STO function, attach the short-circuit connector that came with the drive unit.
- *13 This signal varies depending on the number of axes.

Source I/O interface

For notes, refer to the notes in the following section.

Page 51 Sink I/O interface

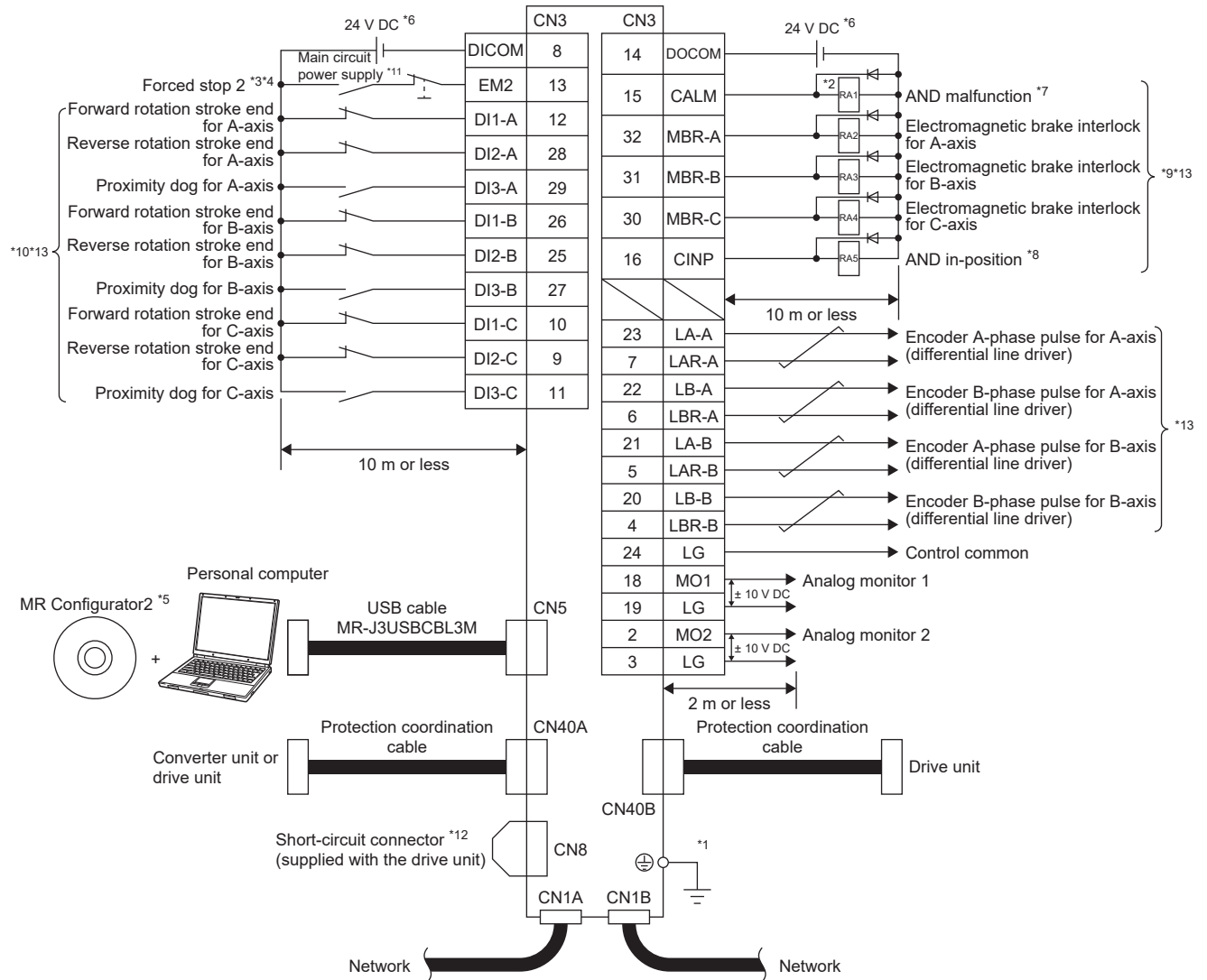

3.3 Explanation of power supply system

Explanation of signals

Point

- For the layout of connectors and terminal blocks, refer to the following.
☞ Page 84 DIMENSIONS

L+/L- (Connection destination: Converter unit)

Connect them with L+ and L- of the converter unit.
Use the bus bar.

L11/L21 (Connection destination: Control circuit power supply)

Supply 1-phase 380 V AC to 480 V AC, 50 Hz/60 Hz power to L11 and L21.

U/V/W/E (Connection destination: Servo motor power supply/servo motor grounding terminal)

Connect them to the servo motor power supply inputs (U/V/W) and servo motor grounding terminal (E). Do not connect devices such as magnetic contactors between the motor and drive unit as this will lead to abnormal operation or malfunction.

⊕ (Connection destination: Protective earth (PE))

Connect this terminal to the protective earth (PE) of the cabinet.

Power-on procedure

Point

Signals such as output signals may be unstable at power-on.

Power-on procedure

1. Wire the power supply using a magnetic contactor between the power supply and the main circuit power supply (L1/L2/L3) of a converter unit by referring to the following section. Switch off the magnetic contactor as soon as an alarm occurs.
☞ Page 42 Example power circuit connections
2. Switch on the control circuit power supply (L11 and L21) of the converter unit and drive unit simultaneously with the main circuit power supply or before switching on the main circuit power supply. If the control circuit power supply is turned on and the servo-on command is transmitted while the main circuit power supply is off, [AL. 0E9 Main circuit off warning] will occur. Turning on the main circuit power supply stops the warning and starts the operation properly.
3. When the main circuit power supply is switched on, the drive unit will receive the servo-on command after startup and initial network communication. The startup time for 1-axis drive units is 2.5 s to 3.5 s, and the startup time for multi-axis drive units is 3.5 s to 4.0 s.

Timing chart

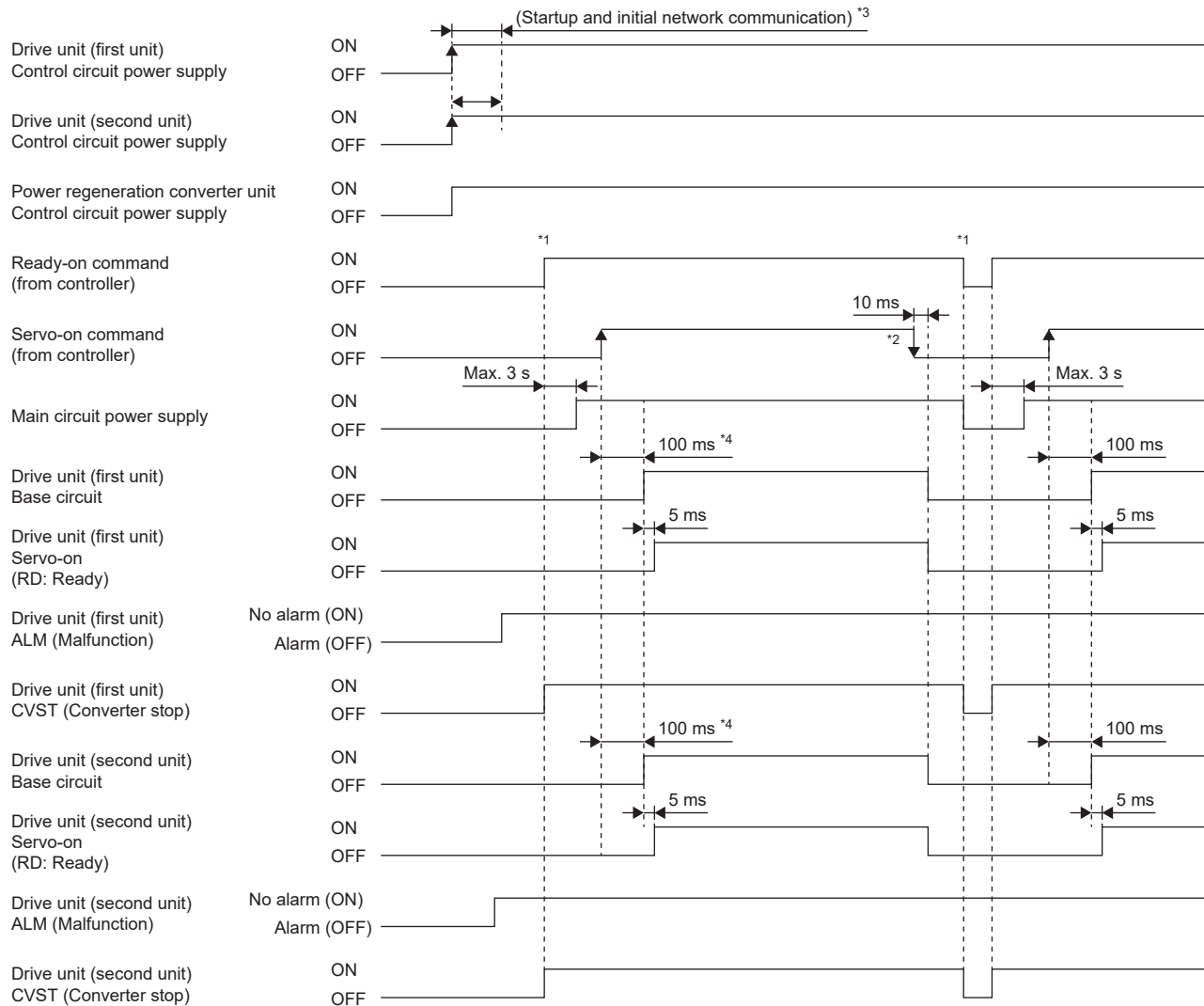

- *1 Input the ready-on command simultaneously to all drive units connected with the protection coordination cable. Otherwise, [AL. 0E9 Main circuit off warning] or [AL. 01B Protection coordination error] may occur.
- *2 If an alarm occurs, turn off all ready-on commands to the drive units connected with the protection coordination cable. Otherwise, [AL. 0E9] or [AL. 01B] may occur when the alarm is reset.
- *3 For a fully closed loop system, this time is 2 s longer.
- *4 To turn off the ready-on command, first turn off the servo-on command and turn off the ready-on command. Otherwise, [AL. 01B] may occur.

Wiring CNP3_

Point

- For the wire sizes, refer to the following.
- ☞ Page 121 Selection example of wires
- When wiring, remove the power connectors from the drive unit.
- Insert only one wire or ferrule into each wire insertion hole on each power connector.

Use the supplied drive unit power connector for wiring CNP3_.
 CNP3A/CNP3B/CNP3C connectors all have the same shape. Ensure that they are connected properly.

Connector

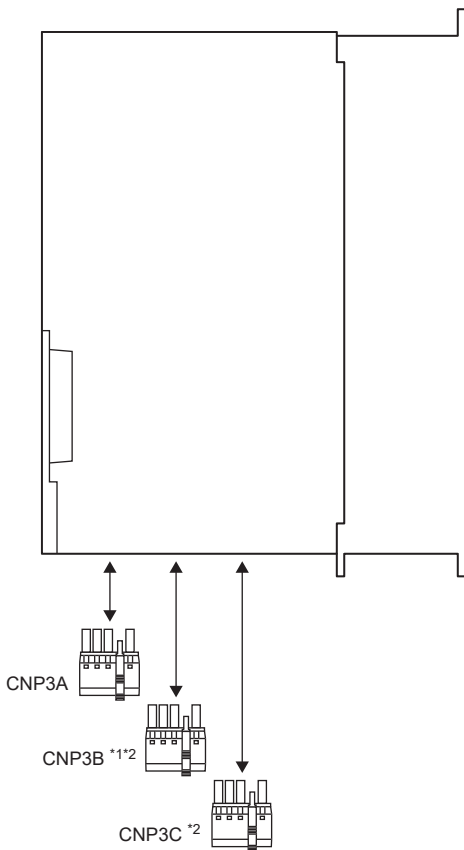

*1 For 2-axis drive units
 *2 For 3-axis drive units

Connector	Receptacle assembly	Applicable wire		Stripped length [mm]	Open tool	Manufacturer
		Size	Insulator OD			
CNP3A	BVF 7.62HP/04/180MSF4	24 to 8 AWG	10 mm ² or less	12	SDS 0.8X4.5X125	Weidmüller
CNP3B	SN BK BX LRP					
CNP3C						

Connecting wires

■ Fabricating the wire insulator

Refer to the following for the stripped length of the wire insulator. Set the appropriate length based on the wire type and fabrication condition.

☞ Page 56 Connector

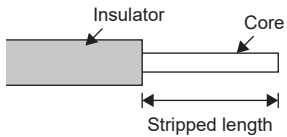

Twist the core wires lightly and straighten them as follows.



A ferrule can also be used when connecting to the connectors. If using a ferrule, choose from one of the ferrules and the crimping tools shown below.

Wire size	Ferrule model (Phoenix Contact)		Crimping tool (Weidmüller)
	Sleeve without insulation cover	Sleeve with insulation cover	
24 to 8 AWG	1.5 mm ² to 10 mm ²	1.5 mm ² to 6 mm ²	PZ 6/5

■ Inserting wire

Insert only one wire or ferrule into each wire insertion hole on each power connector.

- For stranded wire connection

1. Insert the open tool all the way into the clamp opening screwdriver insertion hole.

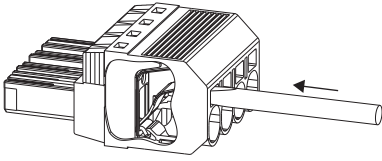

2. Insert a properly stripped wire into the wire insertion hole. The recommended wire strip length is $12\text{ mm} \pm 1\text{ mm}$. Check the wire insertion depth so that the wire insulator is not caught by the spring and that the conductive part of the stripped wire is not exposed.

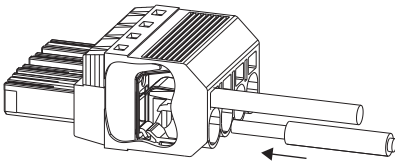

3. Pull out the open tool to fix the wire. Pull the wire lightly to confirm that the wire is surely connected. In addition, confirm that the ends of the core wires do not stick out of the connector.

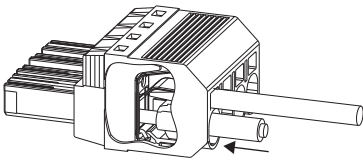

- For solid wire or treated-tip wire

If the wiring cannot be performed as shown in the following procedure, perform the wiring following "For stranded wire connection".

1. Insert a solid wire or a wire with a treated tip all the way into the wire insertion hole.

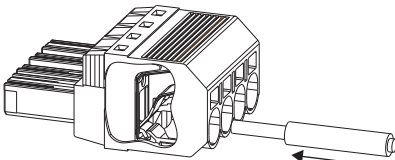

2. Pull the wire lightly to confirm that the wire is surely connected.

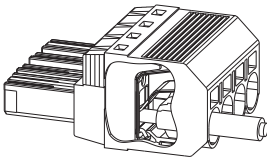

3.4 Connectors and pin assignments

Precautions

- The pin assignments of the connectors are as viewed from the cable connector wiring section.
- For information on the functional safety I/O signal connector (CN8), refer to the following page:

 Page 139 USING STO FUNCTION

Connectors and pin assignments

1-axis drive unit

The front view and bottom view of the drive unit shown below are of MR-J5D1-_G_ drive unit with a rated capacity symbol of 350 or less. Refer to the following for the appearance and connector layout of the other drive units.

☞ Page 84 DIMENSIONS

The frames of the CN2A and CN2AL connectors are connected to the protective earth terminal in the drive unit.

■Front view of drive unit

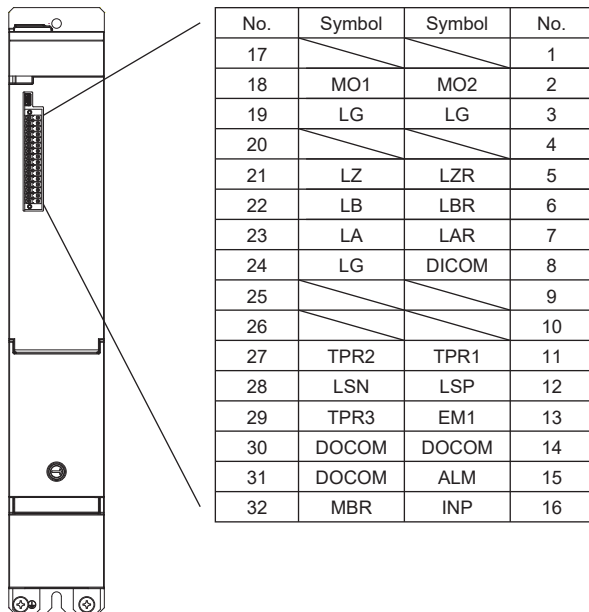

■Bottom view of drive unit

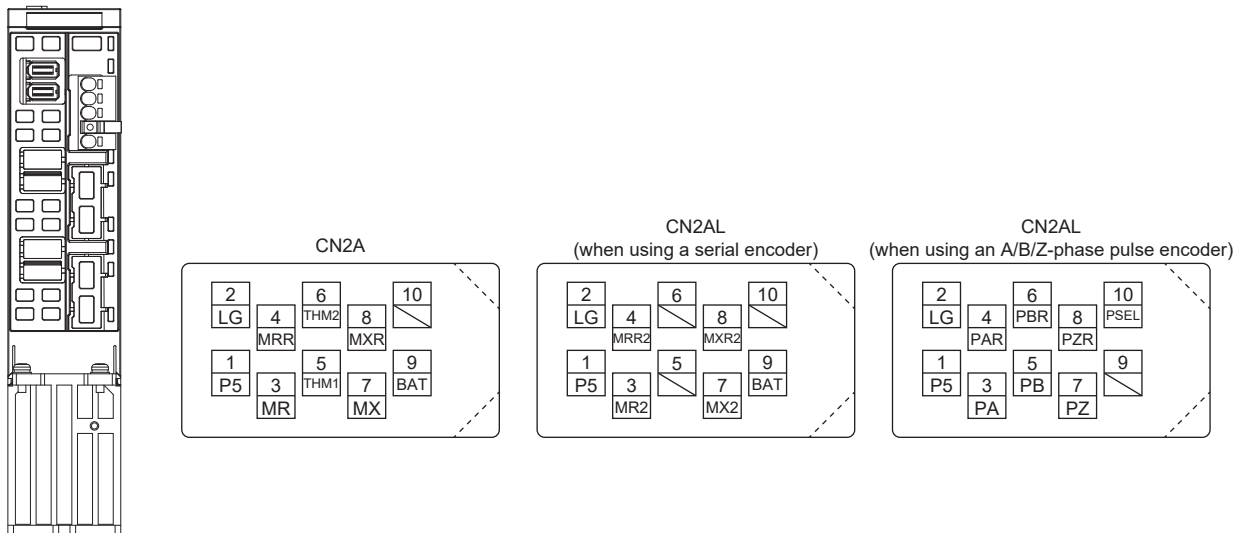

Multi-axis drive unit

The front view and bottom view of the drive unit shown below are of MR-J5D3-_G_ drive unit with a rated capacity symbol of 200 or less. Refer to the following for the appearance and connector layout of the other drive units.

☞ Page 84 DIMENSIONS

The frames of the CN2A connector, CN2B connector, and CN2C connector are connected to the protective earth terminal in the drive unit.

■Front view of drive unit

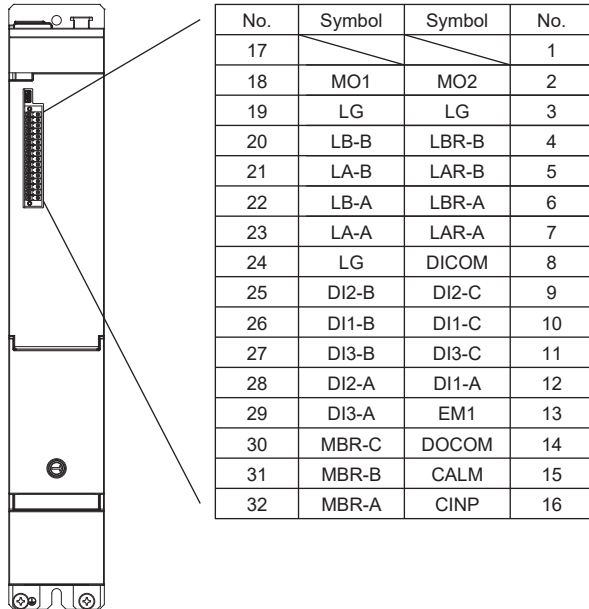

■Bottom view of drive unit

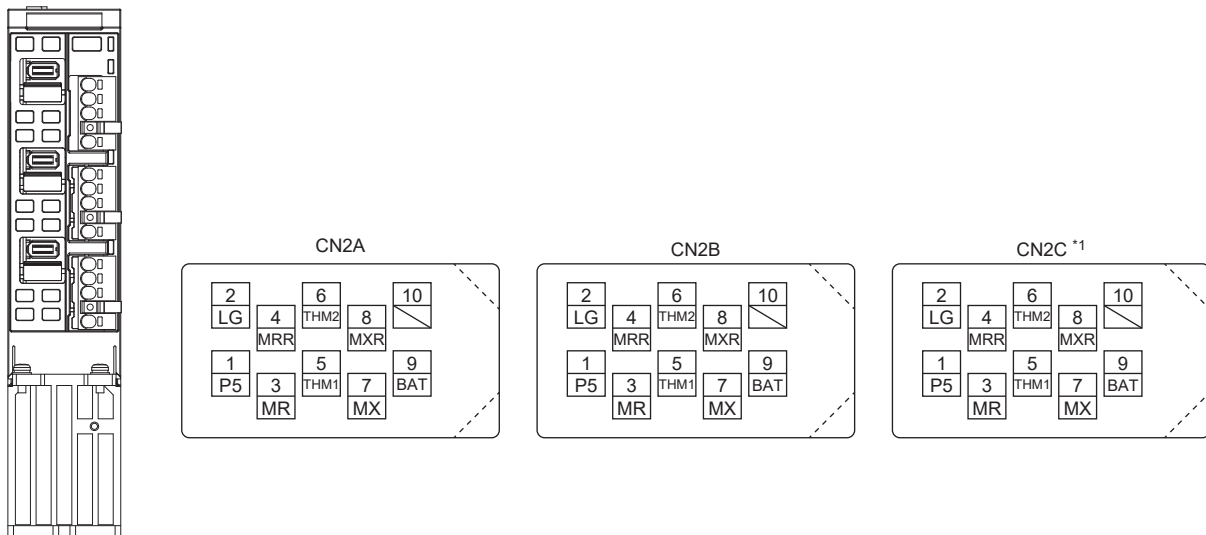

*1 This is for the MR-J5D3-_G_.

3.5 Signal (device) explanation

For the I/O interfaces (symbols in the column "I/O signal interface type" in the table), refer to the following.

☞ Page 77 Detailed explanation of interfaces

The pin numbers in the connector pin No. column are default numbers.

○ and △ in the table show the following.

○: Devices that can be used in factory settings

△: Devices which become available by servo parameter settings

📖 MR-J5-G/MR-J5W-G User's Manual (Parameters)

Input device

Input device pins

The following shows input device pins and the servo parameters used for setting devices.

■MR-J5D1-_G_

Connector pin No.	Servo parameter	Initially assigned device	TPR assignment	I/O signal interface type
CN3-11	[Pr. PD38]	TPR1	Possible	DI-1
CN3-12	[Pr. PD03]	LSP	Impossible	
CN3-13	—	EM2	Impossible	
CN3-27	[Pr. PD39]	TPR2	Possible	
CN3-28	[Pr. PD04]	LSN	Impossible	
CN3-29	[Pr. PD05]	DOG	Possible	

■MR-J5D2-_G_

Connector pin No.	Servo parameter	Initially assigned device	TPR assignment	I/O signal interface type
CN3-11	[Pr. PD51] (common to all axes)	—	Possible	DI-1
CN3-12	[Pr. PD03] (A-axis)	LSP-A	Impossible	
CN3-13	—	EM2	Impossible	
CN3-25	[Pr. PD04] (B-axis)	LSN-B	Impossible	
CN3-26	[Pr. PD03] (B-axis)	LSP-B	Impossible	
CN3-27	[Pr. PD05] (B-axis)	DOG-B	Possible	
CN3-28	[Pr. PD04] (A-axis)	LSN-A	Impossible	
CN3-29	[Pr. PD05] (A-axis)	DOG-A	Possible	

■MR-J5D3-_G_

Connector pin No.	Servo parameter	Initially assigned device	TPR assignment	I/O signal interface type
CN3-9	[Pr. PD04] (C-axis)	LSN-C	Impossible	DI-1
CN3-10	[Pr. PD03] (C-axis)	LSP-C	Impossible	
CN3-11	[Pr. PD05] (C-axis)	DOG-C	Possible	
CN3-12	[Pr. PD03] (A-axis)	LSP-A	Impossible	
CN3-13	—	EM2	Impossible	
CN3-25	[Pr. PD04] (B-axis)	LSN-B	Impossible	
CN3-26	[Pr. PD03] (B-axis)	LSP-B	Impossible	
CN3-27	[Pr. PD05] (B-axis)	DOG-B	Possible	
CN3-28	[Pr. PD04] (A-axis)	LSN-A	Impossible	
CN3-29	[Pr. PD05] (A-axis)	DOG-A	Possible	

Input devices

○ and △ in the table show the following.

○: Devices that can be used in factory settings

△: Devices which become available by servo parameter settings

Device name	Symbol	Availability	I/O signal interface type	Detailed explanation
Forced stop 2	EM2	○	DI-1	☞ Page 63 EM2 (Forced stop 2)
Forced stop 1	EM1	△	DI-1	☞ Page 63 EM1 (Forced stop 1)
Forward rotation stroke end	LSP	○	DI-1	☞ Page 64 LSP (Forward rotation stroke end)/LSN (Reverse rotation stroke end)
Reverse rotation stroke end	LSN	○	DI-1	
Proportional control	PC	△	DI-1	☞ Page 64 PC (Proportional control)
Gain switching	CDP	△	DI-1	☞ Page 64 CDP (Gain switching)
Gain switching 2	CDP2	△	DI-1	☞ Page 64 CDP2 (Gain switching 2)
Fully closed loop selection	CLD	△	DI-1	☞ Page 64 CLD (fully closed loop selection)
Proximity dog	DOG	○	DI-1	☞ Page 64 DOG (Proximity dog)
Touch probe 1	TPR1	*1	DI-1	☞ Page 65 TPR1 (touch probe 1)/TPR2 (touch probe 2)/TPR3 (touch probe 3)
Touch probe 2	TPR2	*1	DI-1	
Touch probe 3	TPR3	*1	DI-1	

*1 The device is available depending on the drive unit. Refer to each section indicated in the detailed explanation column.

Input device explanation

■EM2 (Forced stop 2)

When EM2 is turned off (open between commons), the servo motor decelerates to a stop with commands.

The forced stop will be deactivated if EM2 is turned on (short between commons) while in the forced stop state.

When not using EM2, set [Pr. PA04.3] to "2".

EM2 and EM1 are mutually exclusive. In the torque mode, EM2 functions the same as EM1.

For details, refer to "Forced stop deceleration function" in the following manual.

📖MR-J5 User's Manual (Function)

Setting value		EM2/EM1	Deceleration method	
[Pr. PA04.3]	[Pr. PA04.2]		EM2 or EM1 is off	Alarm occurrence
0	0	EM1	MBR (Electromagnetic brake interlock) turns off without the forced stop deceleration.	MBR (Electromagnetic brake interlock) turns off without the forced stop deceleration.
2	0	EM2	MBR (Electromagnetic brake interlock) turns off after the forced stop deceleration.	MBR (Electromagnetic brake interlock) turns off after the forced stop deceleration.
0	1	Neither EM2 nor EM1 is used.	—	MBR (Electromagnetic brake interlock) turns off without the forced stop deceleration.
2	1	Neither EM2 nor EM1 is used.	—	MBR (Electromagnetic brake interlock) turns off after the forced stop deceleration.

■EM1 (Forced stop 1)

When using EM1, set [Pr. PA04.3] to "0".

When EM1 is turned off (open between commons), the base circuit shuts off, and the dynamic brake operates to decelerate the servo motor to a stop.

The forced stop will be deactivated if EM1 is turned on (short between commons) while in the forced stop state.

■LSP (Forward rotation stroke end)/LSN (Reverse rotation stroke end)

To operate a servo motor, turn on LSP/LSN. Turn LSP/LSN off to bring the servo motor to a stop and switch it to the servo-lock state.

For information about areas such as the supported control modes, automatic on, and restrictions, refer to "Stroke limit function" in the following user's manual.

📖MR-J5 User's Manual (Function)

Input device		Operation	
LSP	LSN	CCW direction (positive direction)	CW direction (negative direction)
1 (on)	1 (on)	○	○
0 (off)	1 (on)	—	○
1 (on)	0 (off)	○	—
0 (off)	0 (off)	—	—

■PC (Proportional control)

Turn PC on to switch the speed amplifier from the proportional integral type to the proportional type.

If a servo motor is rotated even for a pulse due to any external factor while it is at a stop, it generates torque to compensate for a position mismatch. If locking the servo motor shaft mechanically after positioning completes, turn on PC (Proportional control) upon completion of positioning to suppress the unnecessary torque generated for compensation of a position mismatch.

If locking the shaft for a long period of time, set the torque value to be the rated torque or less.

Do not use PC in the torque mode. If PC is used in the torque mode, the servo motor may operate at a speed exceeding the speed limit value.

■CDP (Gain switching)

Turn on CDP to use the values of [Pr. PB29] to [Pr. PB36] and [Pr. PB56] to [Pr. PB60] as the load to motor inertia ratio and individual gain values.

When both CDP and CDP2 are on, the setting of CDP2 is prioritized.

For details, refer to "GAIN SWITCHING FUNCTION" in the following manual.

📖MR-J5 User's Manual (Adjustment)

■CDP2 (Gain switching 2)

Turn on CDP2 to use the values of [Pr. PB67] to [Pr. PB70] as the load to motor inertia ratio and individual gain values.

When both CDP and CDP2 are on, the setting of CDP2 is prioritized.

For details, refer to "GAIN SWITCHING FUNCTION" in the following manual.

📖MR-J5 User's Manual (Adjustment)

■CLD (fully closed loop selection)

This device can be used when the semi closed/fully closed loop control switching is enabled by [Pr. PE01].

The semi closed loop control is selected when CLD is turned off, and fully closed loop control is selected when CLD is turned on.

📖 Page 162 USING A FULLY CLOSED LOOP SYSTEM

■DOG (Proximity dog)

Turning off DOG will detect a proximity dog. The polarity for the proximity dog can be changed with [Pr. PT29.0].

[Pr. PT29.0]	Polarity for proximity dog detection
0	Dog detection with off
1	Dog detection with on

■TPR1 (touch probe 1)/TPR2 (touch probe 2)/TPR3 (touch probe 3)

Refer to the following table for drive units on which TPR1 to TPR3 are available.

○ and △ in the table show the following.

○: Devices that can be used in factory settings

△: Devices which become available by servo parameter settings

Drive unit	TPR1	TPR2	TPR3
MR-J5D1-_G_	○	○	△
MR-J5D2-_G_	△	△	△
MR-J5D3-_G_	△	△	△

These devices enable the touch probe function, which latches the current position with sensor input or by other means.

Turning on this device latches the current position.

For details, refer to "Touch probe" in the following manual.

📖MR-J5 User's Manual (Function)

Output device

Output device pins

The following shows the output device pins and the servo parameters used for assigning devices.

■MR-J5D1-_G_

Connector pin No.	Servo parameter	Initially assigned device	I/O signal interface type
CN3-15	[Pr. PD09]	ALM	DO-1
CN3-16	[Pr. PD08]	INP	
CN3-32	[Pr. PD07]	MBR	

■MR-J5D2-_G_

Connector pin No.	Servo parameter	Initially assigned device	I/O signal interface type
CN3-15	[Pr. PD09] (common to all axes)	ALM	DO-1
CN3-16	[Pr. PD08] (common to all axes)	INP	
CN3-31	[Pr. PD07] (B-axis)	MBR-B	
CN3-32	[Pr. PD07] (A-axis)	MBR-A	

■MR-J5D3-_G_

Connector pin No.	Servo parameter	Initially assigned device	I/O signal interface type
CN3-15	[Pr. PD09] (common to all axes)	ALM	DO-1
CN3-16	[Pr. PD08] (common to all axes)	INP	
CN3-30	[Pr. PD07] (C-axis)	MBR-C	
CN3-31	[Pr. PD07] (B-axis)	MBR-B	
CN3-32	[Pr. PD07] (A-axis)	MBR-A	

Output devices

○ and △ in the table show the following.

○: Devices that can be used in factory settings

△: Devices which become available by servo parameter settings

—: Devices that cannot be used

Device name	Symbol	Availability	I/O signal interface type	Detailed explanation
Malfunction	ALM	○	DO-1	☞ Page 68 ALM (Malfunction)
In-position	INP	○	DO-1	☞ Page 68 INP (In-position)
Ready	RD	○	DO-1	☞ Page 68 RD (Ready)
Speed reached	SA	△	DO-1	☞ Page 68 SA (Speed reached)
Warning	WNG	△	DO-1	☞ Page 68 WNG (Warning)
Battery warning	BWNG	△	DO-1	☞ Page 68 BWNG (Battery warning)
Motor stop warning	WNGSTOP	△	DO-1	☞ Page 68 WNGSTOP (Motor stop warning)
Variable gain enabled	CDPS	△	DO-1	☞ Page 68 CDPS (Variable gain enabled)
Variable gain enabled 2	CDPS2	△	DO-1	☞ Page 68 CDPS2 (Variable gain enabled 2)
Absolute position erased	ABSV	△	DO-1	☞ Page 69 ABSV (Absolute position erased)
Tough drive in progress	MTTR	—	DO-1	☞ Page 69 MTTR (Tough drive in progress)
Fully closed loop selection	CLDS	△	DO-1	☞ Page 69 CLDS (Fully closed loop control in progress)
Converter stop	CVST	△	DO-1	☞ Page 69 CVST (Converter stop)
Electromagnetic brake interlock	MBR	○	DO-1	[G]: ☞ Page 69 MBR (Electromagnetic brake interlock)
Limiting speed	VLC	△	DO-1	[G]: ☞ Page 69 VLC (Limiting speed)
Zero speed detection	ZSP	○	DO-1	[G]: ☞ Page 70 ZSP (Zero speed detection)
Limiting torque	TLC	△	DO-1	[G]: ☞ Page 70 TLC (Limiting torque)
General-purpose output A	DOA	△	DO-1	☞ Page 70 DOA (General-purpose output A)/DOB (General-purpose output B)/DOC (General-purpose output C)
General-purpose output B	DOB	△		
General-purpose output C	DOC	△		

Output device explanation

■ALM (Malfunction)

If the protective circuit operates and shuts off the base circuit, ALM will turn off.

If an alarm is not occurring, ALM will turn on in 2.5 s to 3.5 s after power-on (or in 3.5 s to 4.0 s for a multi-axis drive unit).

For details, refer to "Alarm function" in the following manual.

📖MR-J5 User's Manual (Function)

■INP (In-position)

If droop pulses are within the in-position range, INP will turn on. The in-position range can be changed with [Pr. PA10]. When the servo motor is operated at low speed by increasing the in-position range, INP may remain on.

The device cannot be used in the velocity mode or torque mode.

For details, refer to "In-position range setting" in the following manual.

📖MR-J5 User's Manual (Function)

■RD (Ready)

When the drive unit is switched to the servo-on state, RD switches on.

■SA (Speed reached)

At servo-off, SA is off. When the servo motor speed reaches the following range, SA turns on.

Set speed $\pm ((\text{Set speed} \times 0.05) + 20)$ r/min (mm/s)

When the set speed is 20 r/min (mm/s) or less, SA is always on.

The device cannot be used in the position mode and torque mode.

■WNG (Warning)

WNG turns on when a warning occurs. If a warning is not occurring, WNG will turn off in 2.5 s to 3.5 s after power-on (or in 3.5 s to 4.0 s for a multi-axis drive unit).

■BWNG (Battery warning)

If [AL. 092 Battery cable disconnection warning] or [AL. 09F Battery warning] occurs, BWNG will turn on. If a battery warning is not occurring, BWNG will turn off in 2.5 s to 3.5 s after power-on (or in 3.5 s to 4.0 s for a multi-axis drive unit).

In an absolute position detection system with a battery-less ABS encoder, BWNG is always off.

■WNGSTOP (Motor stop warning)

WNGSTOP will turn on if a warning that the motor cannot be driven occurs. If a motor stop warning is not occurring, WNGSTOP will turn off in 2.5 s to 3.5 s after power-on (or in 3.5 s to 4.0 s for a multi-axis drive unit).

■CDPS (Variable gain enabled)

When the gain of "Gain switching" is enabled, CDPS is on.

■CDPS2 (Variable gain enabled 2)

If the gain of "Gain switching 2" is enabled, CDPS2 will turn on.

■ABS (Absolute position erased)

ABS turns on when the absolute position is undetermined.

📖 Page 135 ABSOLUTE POSITION DETECTION SYSTEM

■MTTR (Tough drive in progress)

MTTR is always off.

■CLDS (Fully closed loop control in progress)

When the fully closed loop control is in progress, the CLDS is on.

■CVST (Converter stop)

CVST turns on when the ready-on command is received.

It turns off when an alarm that stops the converter main circuit occurs.

📖MR-J5 User's Manual (Troubleshooting)

■MBR (Electromagnetic brake interlock)

MBR is off in the servo-off state or at an alarm occurrence.

If using the device, set an operation delay time of the electromagnetic brake in [Pr. PC02].

For details, refer to "Electromagnetic brake interlock function" in the following manual.

📖MR-J5 User's Manual (Function)

■VLC (Limiting speed)

If the speed reaches the speed limit value in the torque mode, VLC will turn on. VLC will turn off in the servo-off state.

The device cannot be used in the position mode or the velocity mode.

For details, refer to "Speed limit" in the following manual.

📖MR-J5 User's Manual (Function)

■ZSP (Zero speed detection)

If the servo motor speed is the zero speed or less, ZSP will turn on. The zero speed can be changed with [Pr. PC07]. The following shows an example when the initial value (50) is set in [Pr. PC07].

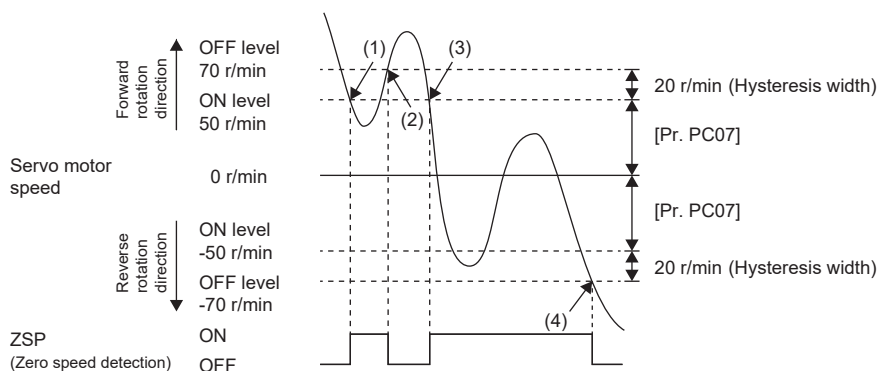

ZSP will turn on when the servo motor speed is reduced to 50 r/min (at (1)), and will turn off when the servo motor is increased to 70 r/min again (at (2)).

ZSP will turn on when the servo motor is decelerated again to 50 r/min (at (3)), and will turn off when the servo motor speed reaches -70 r/min (at (4)).

The range from the point when the servo motor speed has reached the on-level and ZSP turns on, to the point when the speed has increased again and reached the off-level is called a hysteresis width.

The hysteresis width is 20 r/min for this drive unit.

■TLC (Limiting torque)

If the torque reaches the torque limit value when torque is generated, TLC will turn on. TLC will turn off in the servo-off state. In the torque mode, TLC is off.

For details, refer to "Torque limit" in the following manual.

📖MR-J5 User's Manual (Function)

■DOA (General-purpose output A)/DOB (General-purpose output B)/DOC (General-purpose output C)

The pins to which the device is assigned can be switched on/off with the object "Digital outputs". For details, refer to "[Digital outputs (Obj. 60FEh)]" in the User's Manual (Object Dictionary).

Output signal

Output signal explanation

■LA/LAR (Encoder A-phase pulse (differential line driver))/LB/LBR (Encoder B-phase pulse (differential line driver))

These devices output encoder output pulses set in [Pr. PA15] and [Pr. PA16] in the differential line driver type.

When the servo motor rotates in the CCW direction, the encoder B-phase pulse lags the encoder A-phase pulse by a phase of 90 degrees.

The relation between rotation direction and phase difference of the A-phase and B-phase pulses can be changed with the servo parameter "Encoder output pulse - Phase selection".

[G]: [Pr. PC03.0]

Output pulse setting, dividing ratio setting, and electronic gear setting can be selected.

The maximum output frequency is 4.6 Mpulses/s.

For details, refer to "A/B/Z-phase pulse output function" in the following manual.

📖MR-J5 User's Manual (Function)

■LZ/LZR (Encoder Z-phase pulse (differential line driver))

The encoder zero-point signal is output in the differential line driver type. One pulse is output per servo motor revolution. LZ/LZR are on at the zero-point position.

The minimum pulse width is about 400 μ s. For homing using this pulse, set the creep speed to 100 r/min or less.

Multi-axis drive units do not support this output signal.

For details, refer to "A/B/Z-phase pulse output function" in the following manual.

📖MR-J5 User's Manual (Function)

■MO1 (Analog monitor 1)

This signal outputs the data set in the servo parameter "Analog monitor 1 output selection" to between MO1 and LG in terms of voltage.

[G]: [Pr. PC09.0-1]

Output voltage: ± 10 V

Resolution: 10 bits or its equivalent

For details, refer to "Analog monitor" in the following manual.

📖MR-J5 User's Manual (Function)

■MO2 (Analog monitor 2)

This signal outputs the data set in the servo parameter "Analog monitor 2 output selection" to between MO2 and LG in terms of voltage.

[G]: [Pr. PC10.0-1]

Output voltage: ± 10 V

Resolution: 10 bits or its equivalent

For details, refer to "Analog monitor" in the following manual.

📖MR-J5 User's Manual (Function)

Power supply

Power supply explanations

■DICOM (Digital input I/F power supply)

Input 24 V DC (24 V DC \pm 10 %, 300 mA) for I/O interfaces.

For sink interfaces, connect the positive terminal of the 24 V DC external power supply.

For source interfaces, connect the negative terminal of the 24 V DC external power supply.

■DOCOM (Digital output I/F power supply)

Input 24 V DC (24 V DC \pm 10 %, 300 mA) for I/O interfaces.

For sink interfaces, connect the negative terminal of the 24 V DC external power supply.

For source interfaces, connect the positive terminal of the 24 V DC external power supply.

■LG (Monitor common)

LG is a common terminal of MO1 and MO2.

3.6 Interface

Internal connection diagram



Refer to the following for the CN8 connector.

Page 139 USING STO FUNCTION

1-axis drive unit

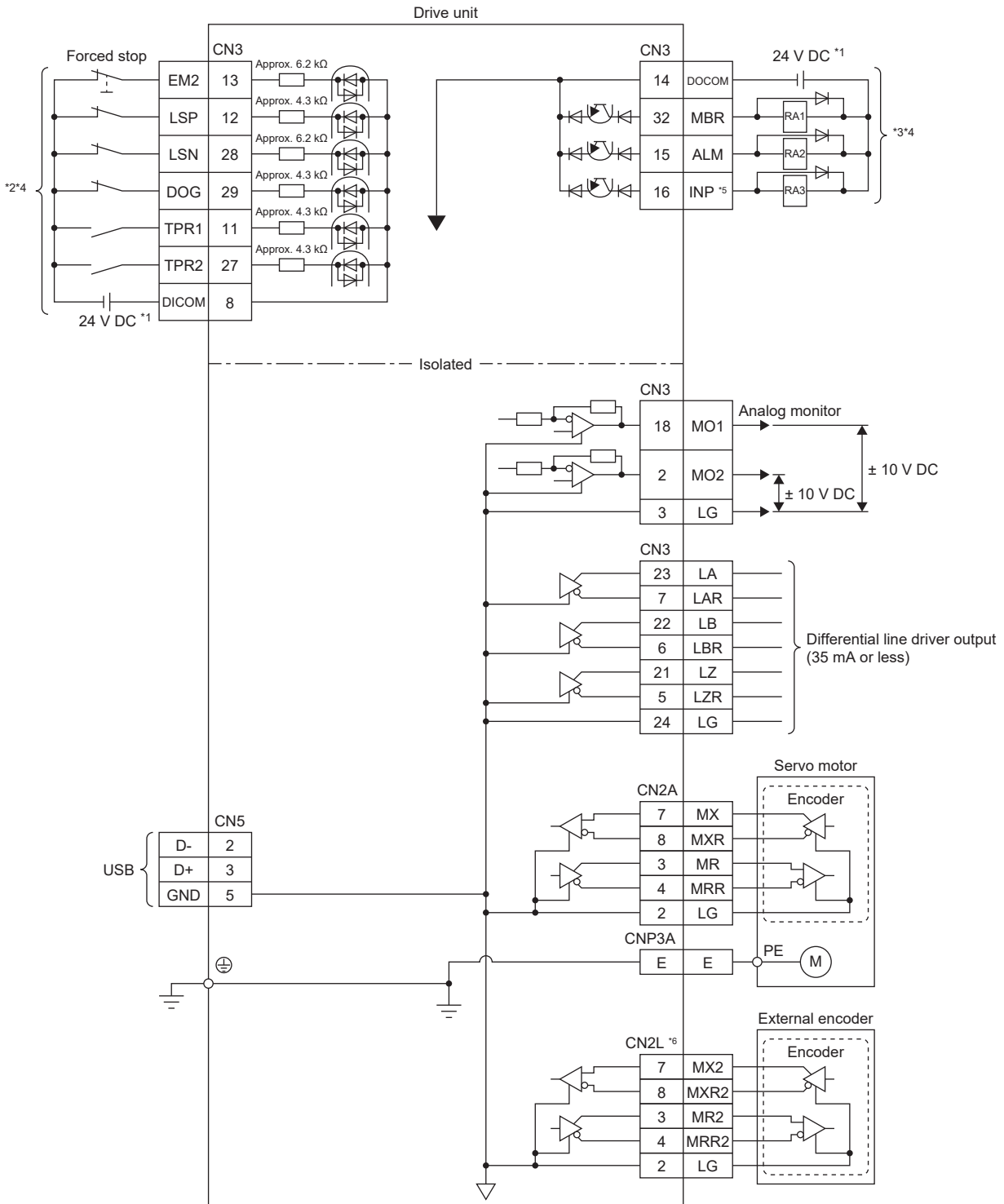

- *1 Although the diagram shows the input signal and the output signal each using a separate 24 V DC power supply for illustrative purposes, the system can be configured to use a single 24 V DC power supply.
- *2 Signals can be assigned to these pins with servo parameters ([Pr. PD03] to [Pr. PD05]).
- *3 Signals can be assigned to these pins with servo parameters ([Pr. PD07] to [Pr. PD09]).
- *4 This diagram shows a sink I/O interface.
- *5 The signal cannot be used in the velocity mode and torque mode.
- *6 Refer to "Parts identification" in User's Manual (Introduction) for connecting an external encoder.

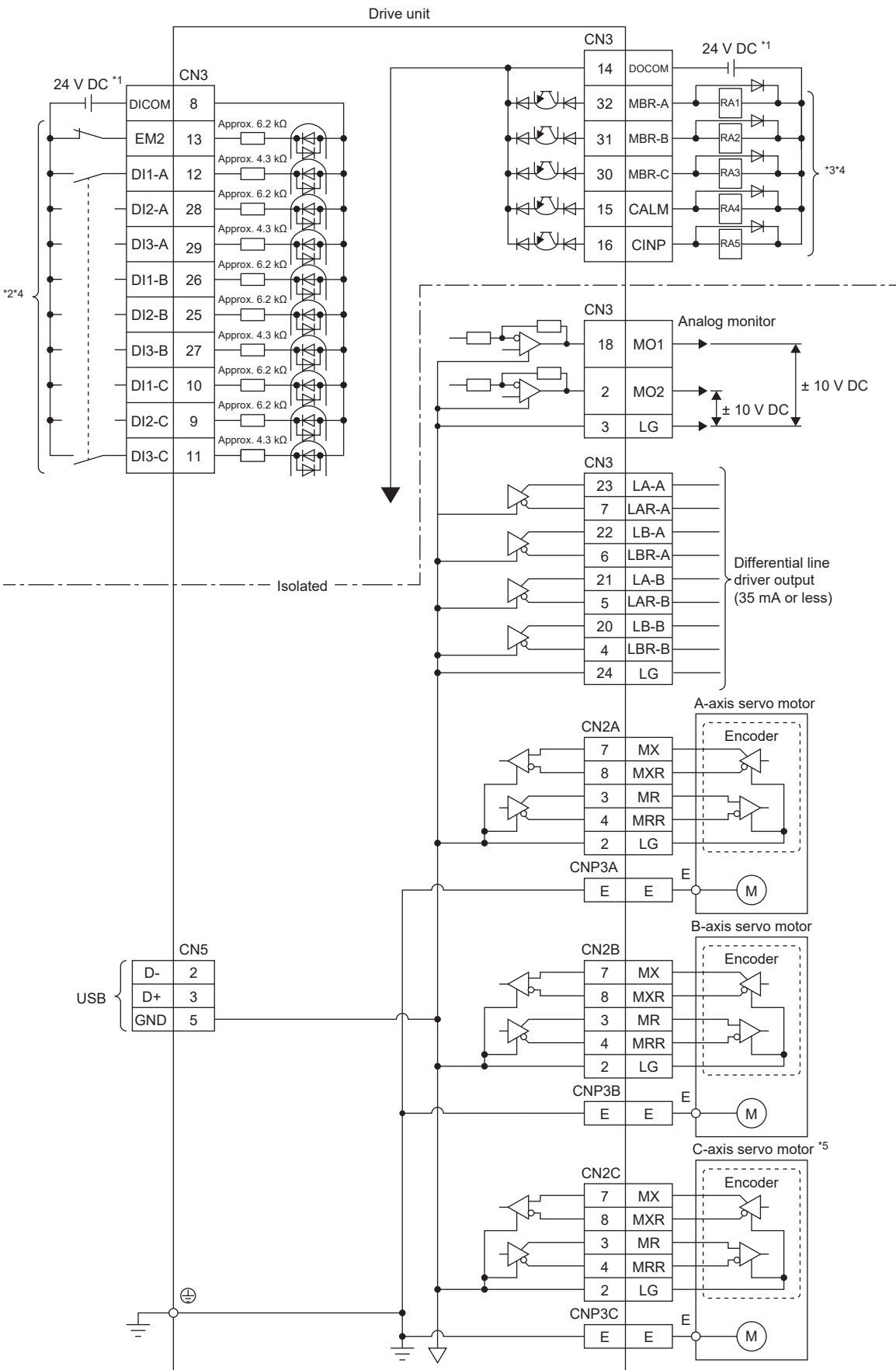

- *1 Although the diagram shows the input signal and the output signal each using a separate 24 V DC power supply for illustrative purposes, the system can be configured to use a single 24 V DC power supply.
- *2 Signals can be assigned to these pins with servo parameters ([Pr. PD03] to [Pr. PD05]).
- *3 Signals can be assigned to these pins with servo parameters ([Pr. PD07] to [Pr. PD09]).
- *4 This diagram shows a sink I/O interface.
- *5 For 3-axis drive units.

Detailed explanation of interfaces

The details of I/O signal interfaces stated in the following section (refer to the I/O signal interface type in the table) are as follows. Refer to the section and connect them with external devices.

☞ Page 62 Signal (device) explanation

Digital input interface DI-1

This is an input circuit in which the photocoupler cathode side is the input terminal. Transmit signals from a sink (open-collector) type transistor output, relay switch, etc. The following connection diagram is for sink input.

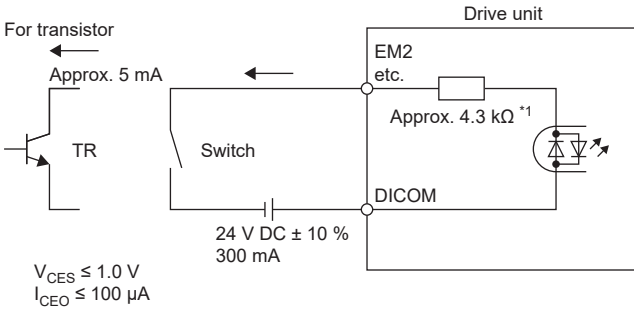

*1 For interfaces of the CN3-13 pin and CN3-28 pin, approximately 6.2 kΩ.

For interfaces of the CN3-9 pin, CN3-10 pin, CN3-13 pin, CN3-25 pin, CN3-26 pin, and CN3-28 pin of the MR-J5D2- _G_/MR-J5D3- _G_, approximately 6.2 kΩ.

☞ Page 73 Internal connection diagram

Digital output interface DO-1

This is a circuit in which the collector of the output transistor is the output terminal. When the output transistor is turned on, the current flows to the collector terminal.

A lamp, relay, or photocoupler can be driven. Install a diode (D) for an inductive load, or install an inrush current suppressing resistor (R) for a lamp load.

(Rated current: 40 mA or less, maximum current: 50 mA or less, inrush current: 100 mA or less) A maximum of 2.6 V voltage drop occurs in the drive unit. The following connection diagram is for the sink output.

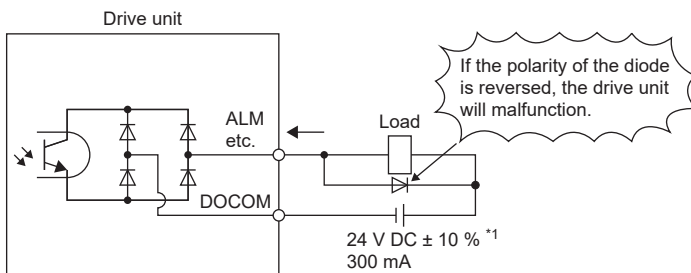

*1 If the voltage drop (a maximum of 2.6 V) interferes with the relay operation, apply high voltage (a maximum of 26.4 V) from an external source.

Refer to the following for the source output.

☞ Page 80 Source I/O interface

Encoder output pulse DO-2

■ Differential line driver type

- Interface

Maximum output current: 35 mA

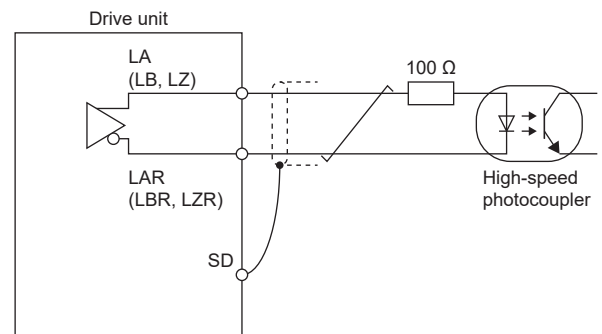
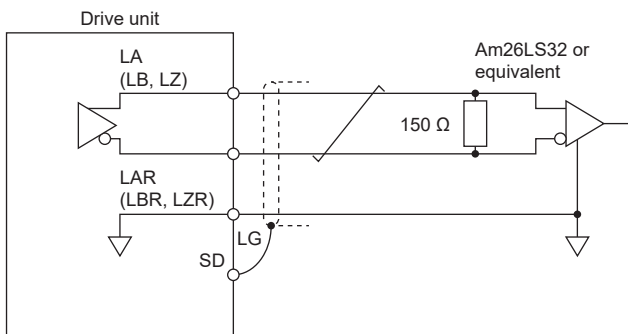

- Output pulse

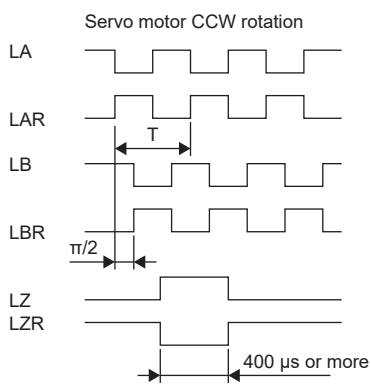

■ Open-collector type

- Interface

Maximum output current: 35 mA

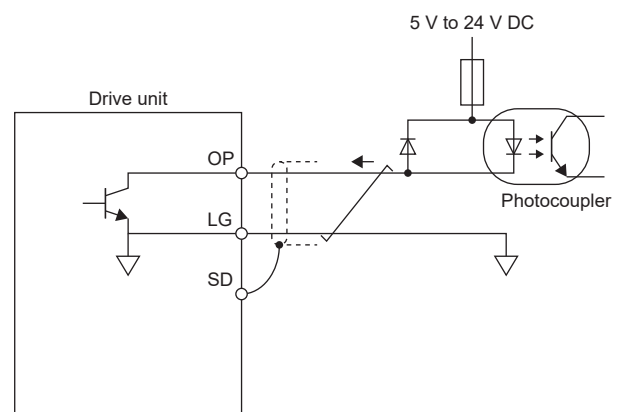
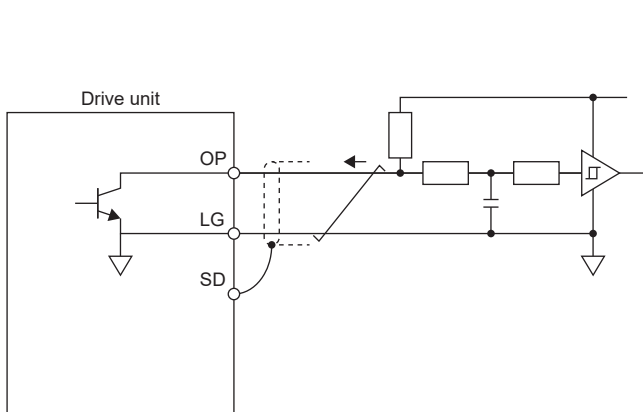

Analog output AO-1

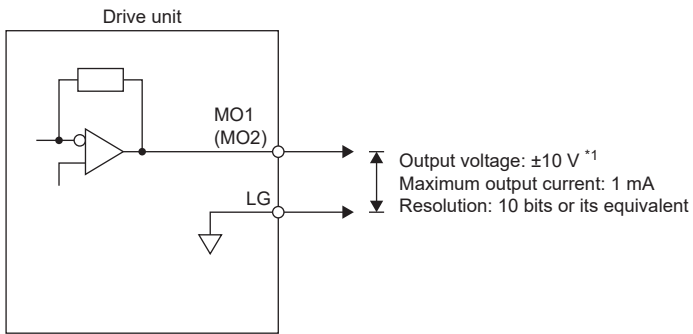

*1 The output voltage varies depending on the output contents.

Source I/O interface

For this drive unit, source type I/O interfaces can be used.

Digital input interface DI-1

This is an input circuit in which the anode of the photocoupler is the input terminal. Transmit signals from a source (open-collector) type transistor output, relay switch, etc.

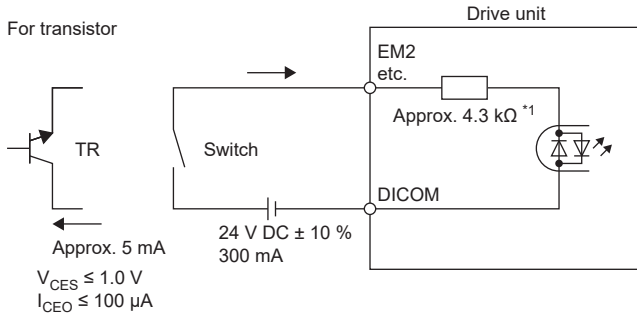

- *1 For interfaces of the CN3-13 pin and CN3-28 pin, approximately 6.2 kΩ.
For interfaces of the CN3-9 pin, CN3-10 pin, CN3-13 pin, CN3-25 pin, CN3-26 pin, and CN3-28 pin of the MR-J5D2-_G_/MR-J5D3-_G_, approximately 6.2 kΩ.

Page 73 Internal connection diagram

Digital output interface DO-1

This is a circuit in which the emitter of the output transistor is the output terminal. When the output transistor is turned on, the current flows from the output terminal to a load.

A maximum of 2.6 V voltage drop occurs in the drive unit.

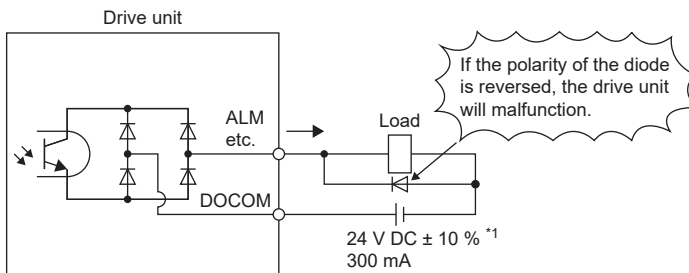

- *1 If the voltage drop (a maximum of 2.6 V) interferes with the relay operation, apply high voltage (a maximum of 26.4 V) from an external source.

3.7 Servo motor with an electromagnetic brake

Precautions

- For specifications such as the power supply capacity and operation delay time of the electromagnetic brake, and for selecting the surge absorber for the electromagnetic brake, refer to "Characteristics of electromagnetic brake" in the following manual.

📖 Rotary Servo Motor User's Manual (HK series)

- The electromagnetic brake on the servo motor is designed to hold the motor shaft. Do not use it for normal braking.
- Incorrect wiring, service life, or the mechanical structure (e.g. when coupled via a timing belt) may cause the electromagnetic brake to be unable to hold the motor shaft. To ensure safety, install a stopper on the machine side.
- If it is assumed that a hazardous situation may arise when the equipment power is off or a product malfunction occurs, use a servo motor with an electromagnetic brake or provide an external brake system for holding purpose to prevent such hazard.
- Configure an electromagnetic brake circuit that interlocks with the external emergency stop switch.
- Before operating the servo motor, confirm that the electromagnetic brake operates properly.
- For the power supply of the electromagnetic brake, use the power supply designed exclusively for the electromagnetic brake.
- If using EM2 (Forced stop 2), use MBR (Electromagnetic brake interlock) for operating the electromagnetic brake.
- If using the servo motor with the electromagnetic brake, the electromagnetic brake will operate when the power (24 V DC) turns off.
- If using the servo motor with the electromagnetic brake, turn off the servo-on command after the servo motor stops.

Connection diagram

1-axis drive unit

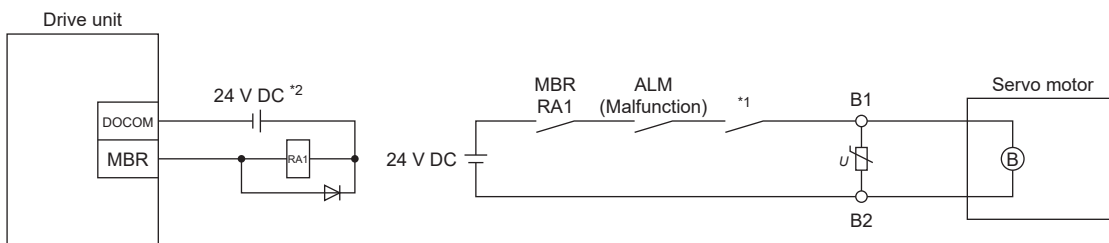

*1 Configure a circuit which interlocks with an emergency stop switch to shut off.
*2 Do not use the 24 V DC interface power supply for the electromagnetic brake.

Multi-axis drive unit

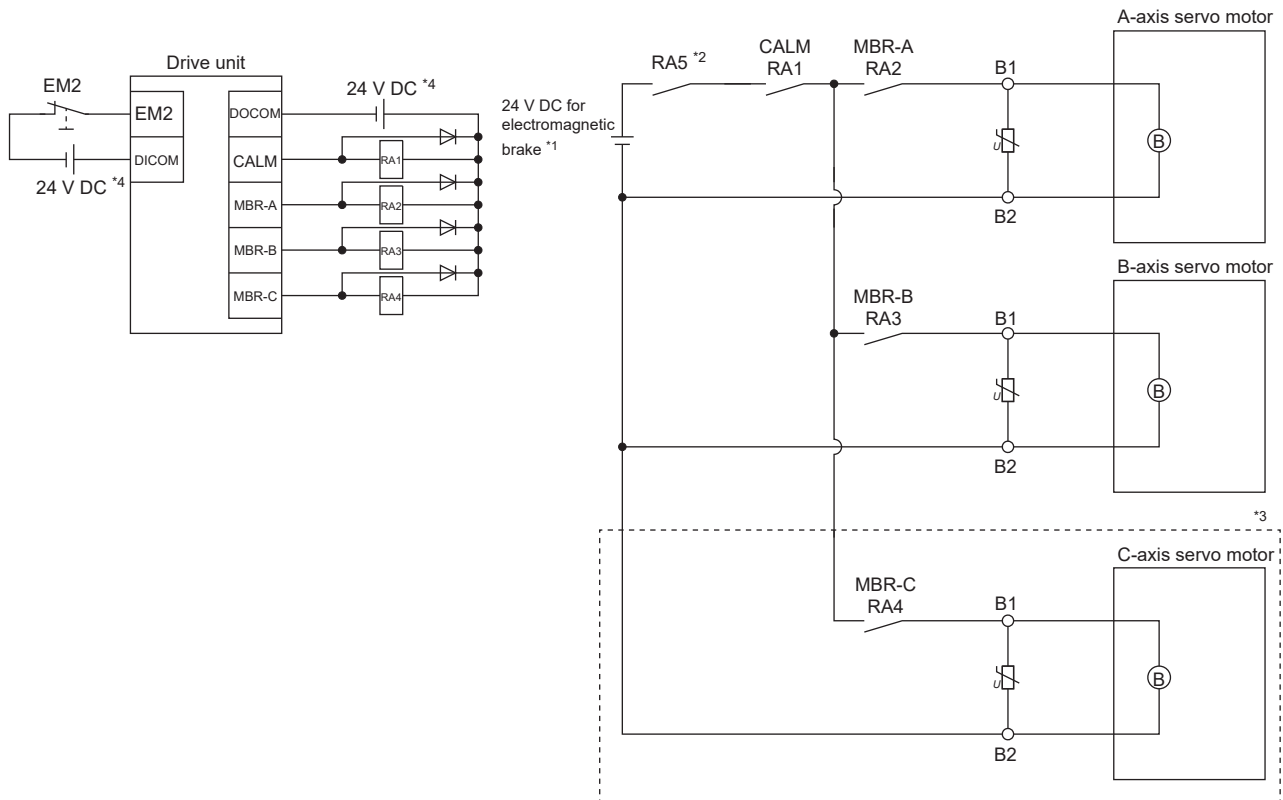

*1 Do not use the 24 V DC interface power supply for the electromagnetic brake.

*2 Configure a circuit which interlocks with an emergency stop switch to shut off.

*3 This connection is for a 3-axis drive unit.

*4 Although the diagram shows the input signal and the output signal each using a separate 24 V DC power supply for illustrative purposes, the system can be configured to use a single 24 V DC power supply.

3.8 Grounding

The drive unit supplies power to the servo motor by switching on and off a power transistor. Depending on the wiring and ground wire routing, the drive unit may be affected by the switching noise (due to di/dt and dv/dt) of the transistor. To prevent such a fault, refer to the following diagram and ground it.

For information on how to comply with the EMC Directive, refer to "EMC Installation Guidelines".

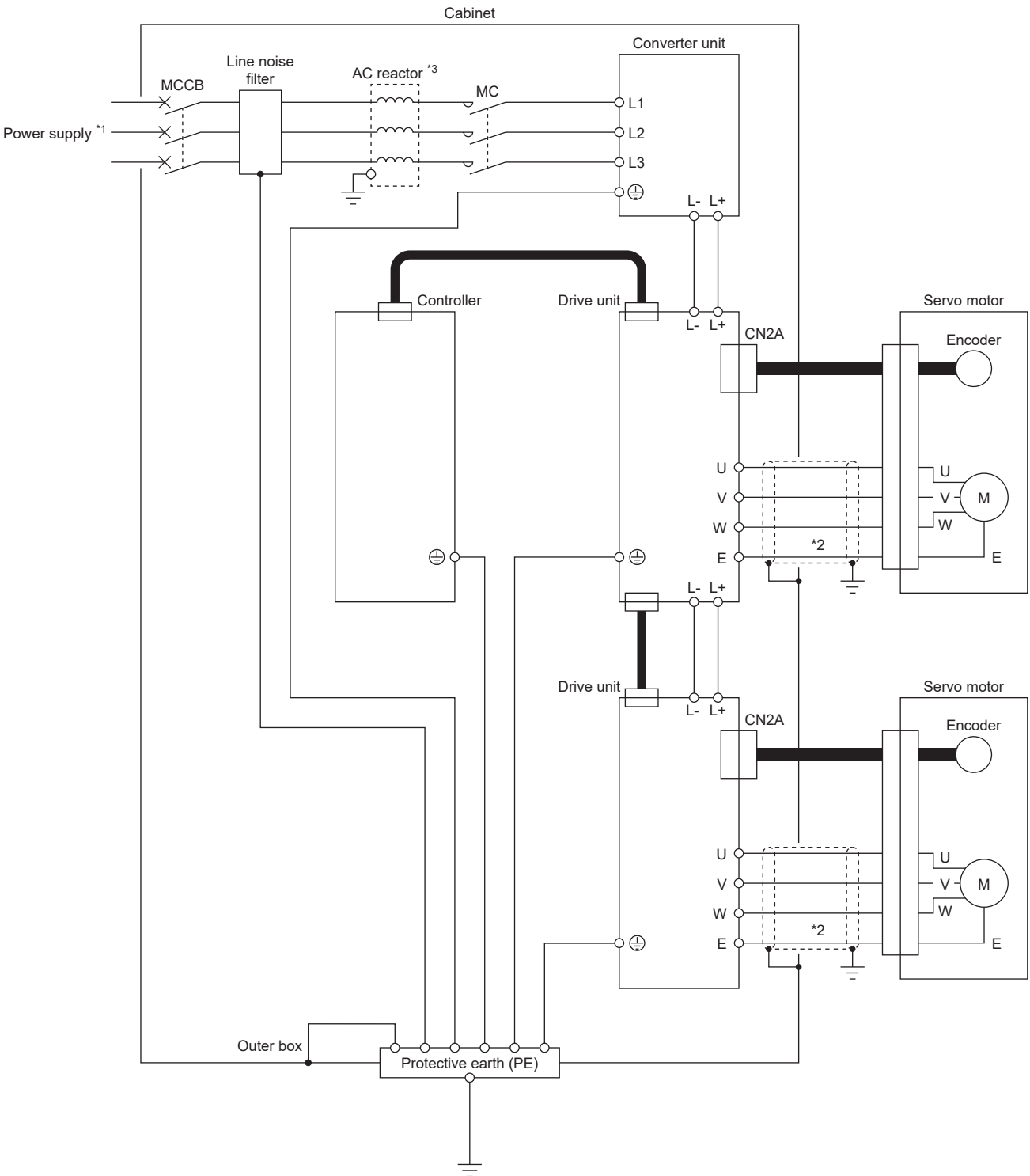

- *1 For the power supply specifications, refer to "Drive unit standard specifications" in the User's Manual (Introduction) and "Standard specifications" in the "MR-CV Power Regeneration Converter Unit User's Manual".
- *2 To ground the servo motor, connect the grounding lead wire to the drive unit, and then connect the wire from the drive unit to the ground via the protective earth (PE) terminal of the cabinet. Do not connect the wire directly to the protective earth (PE) terminal of the cabinet.
- *3 Install the MR-AL- AC reactor.

4 DIMENSIONS

4.1 400 V class

MR-J5D1-100G4 to MR-J5D1-350G4

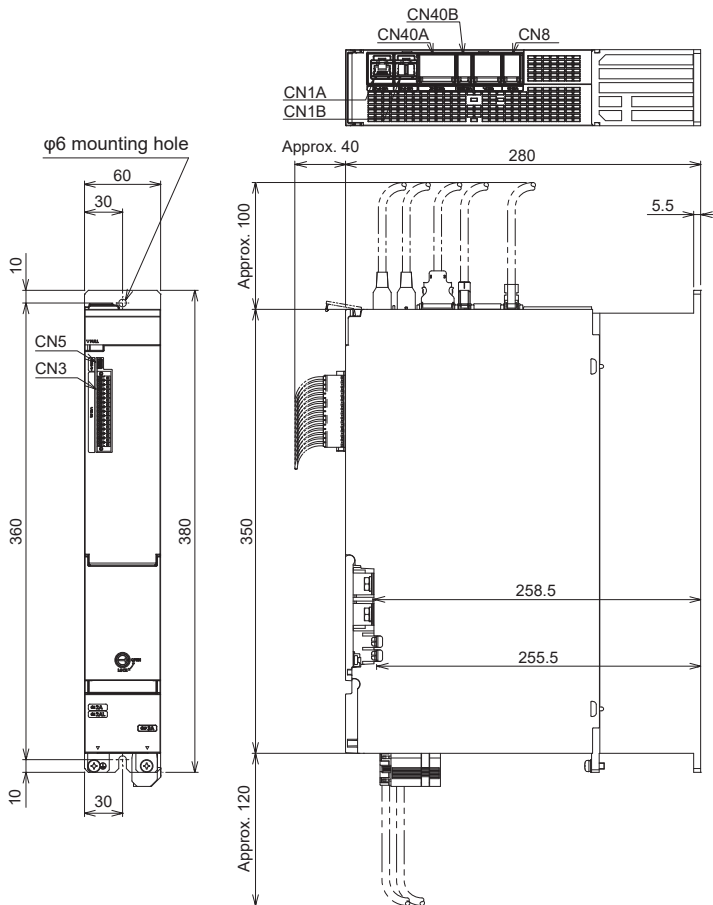

Terminal block location diagram (drawn with the cover removed)

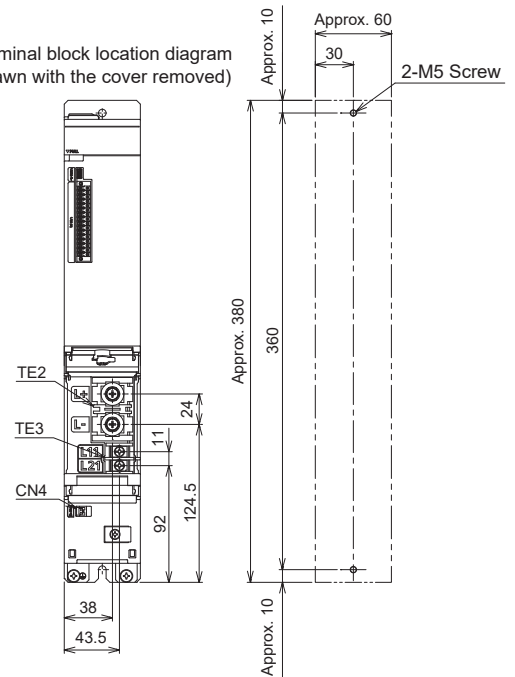

Mounting hole location diagram

Mounting screw
Screw size: M5
Tightening torque: 3.24 [N•m]

Terminal assignment

CNP3A	TE2	TE3
W	L+	L11
V	L-	L21
U		
E		

PE

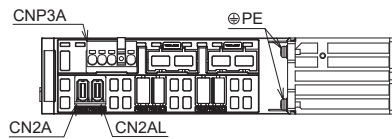

- TE2 Screw size: M6
Tightening torque: 3.0 [N•m]
- TE3 Screw size: M4
Tightening torque: 1.2 [N•m]
- PE Screw size: M5
Tightening torque: 2.0 [N•m]

MR-J5D1-500G4/MR-J5D1-700G4

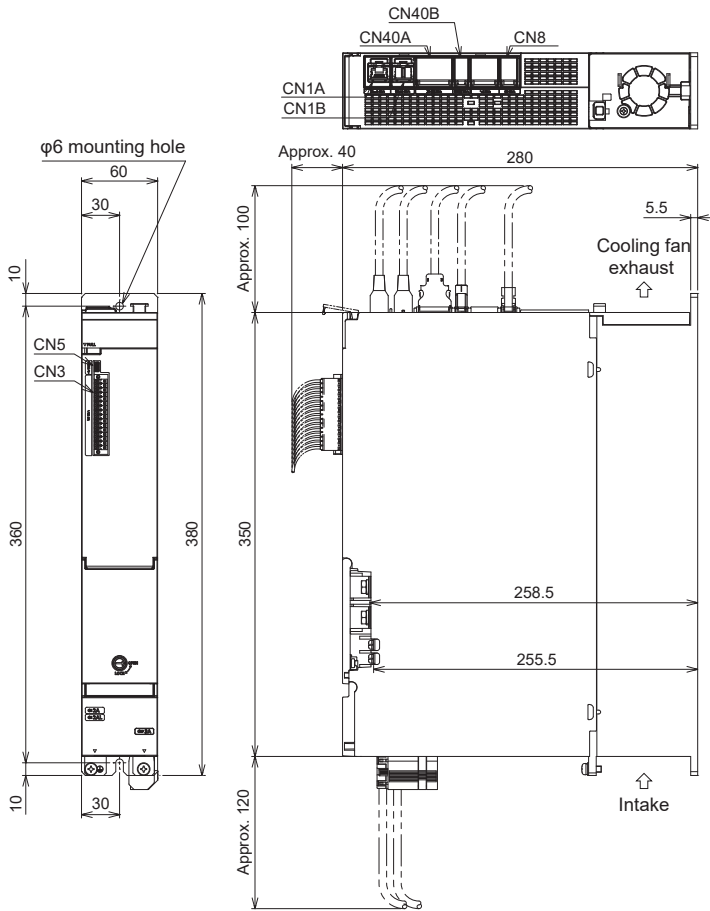

Terminal block location diagram
(drawn with the cover removed)

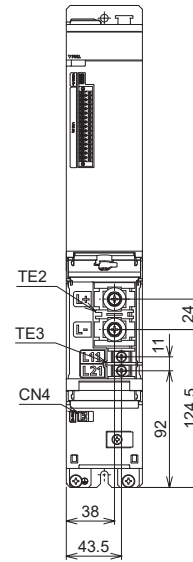

Mounting hole location diagram

Mounting screw
Screw size: M5
Tightening torque: 3.24 [N•m]

Terminal assignment

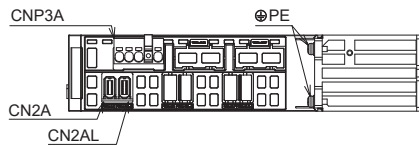
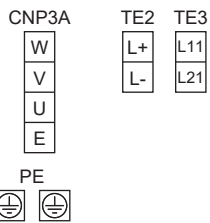

- TE2 Screw size: M6
Tightening torque: 3.0 [N•m]
- TE3 Screw size: M4
Tightening torque: 1.2 [N•m]
- PE Screw size: M5
Tightening torque: 2.0 [N•m]

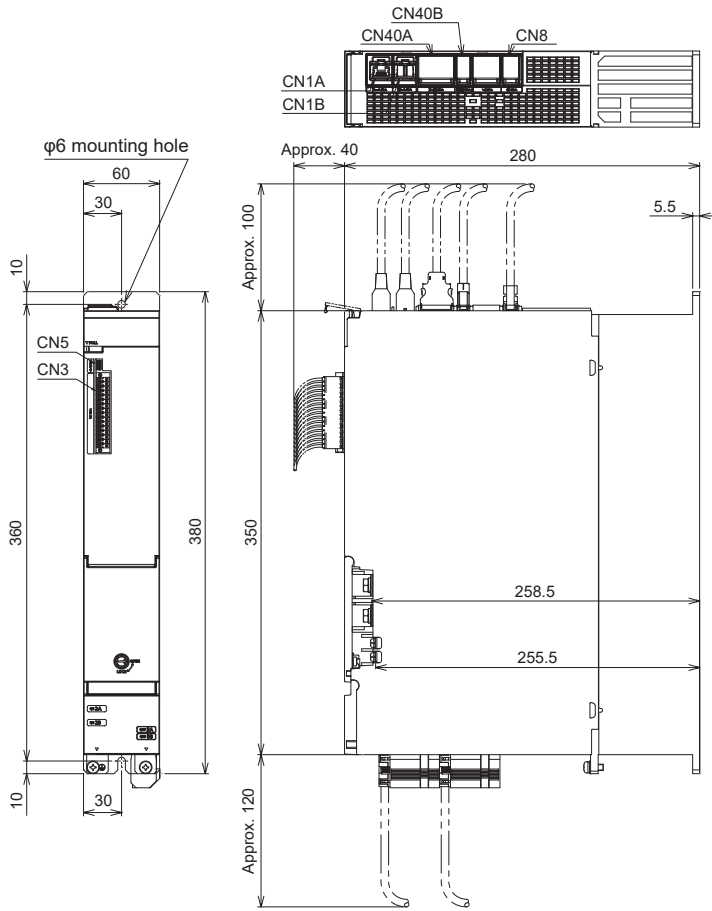

Terminal block location diagram
(drawn with the cover removed)

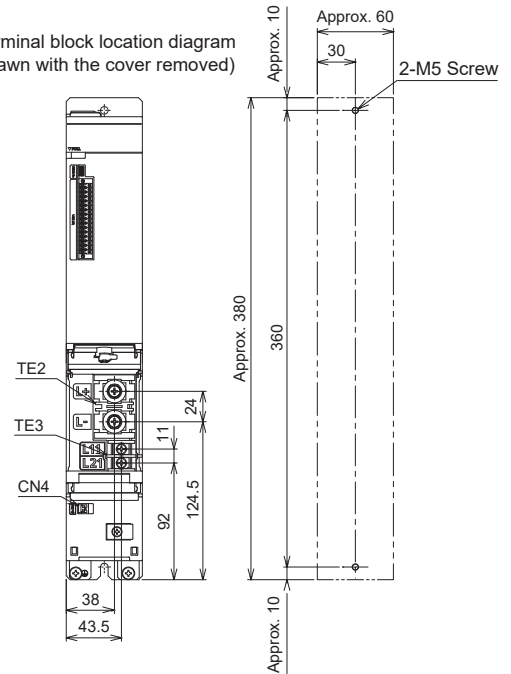

Mounting hole location diagram

Mounting screw
Screw size: M5
Tightening torque: 3.24 [N•m]

Terminal assignment

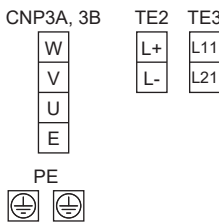

- TE2 Screw size: M6
Tightening torque: 3.0 [N•m]
- TE3 Screw size: M4
Tightening torque: 1.2 [N•m]
- PE Screw size: M5
Tightening torque: 2.0 [N•m]

MR-J5D2-200G4/MR-J5D2-350G4

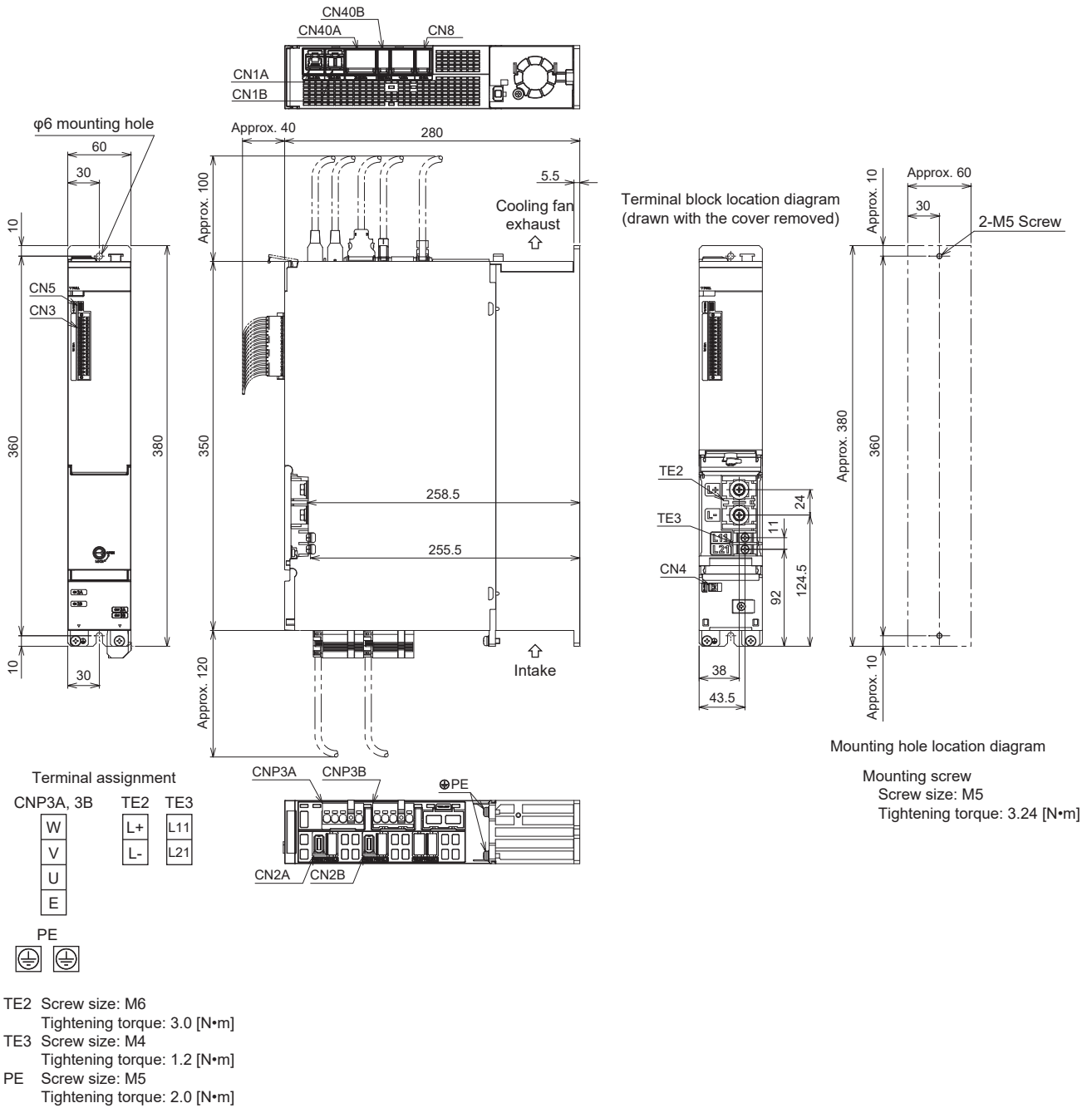

MR-J5D2-500G4/MR-J5D2-700G4

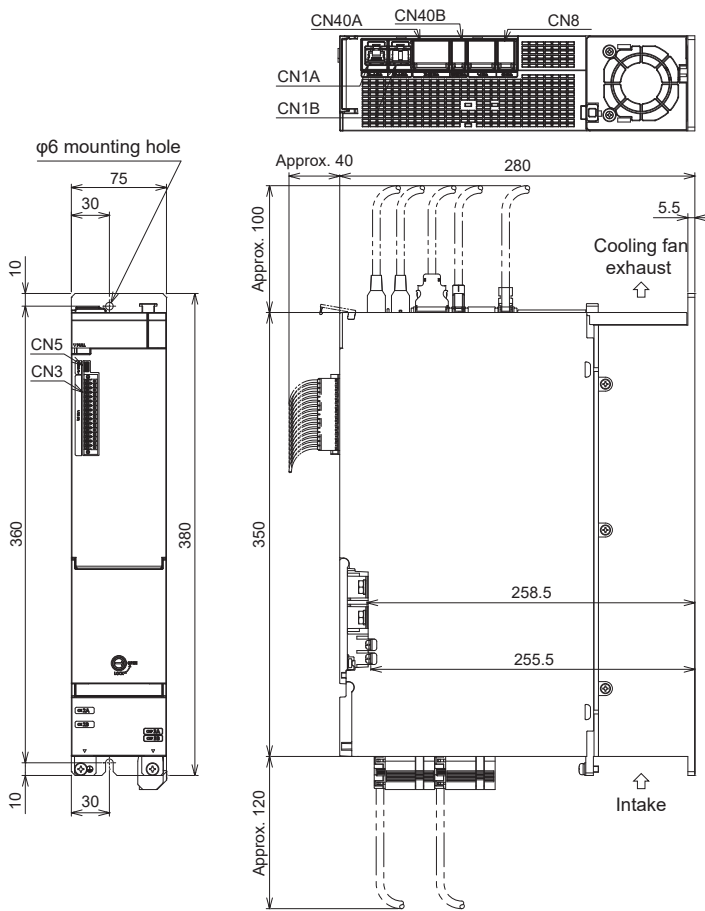

Terminal block location diagram (drawn with the cover removed)

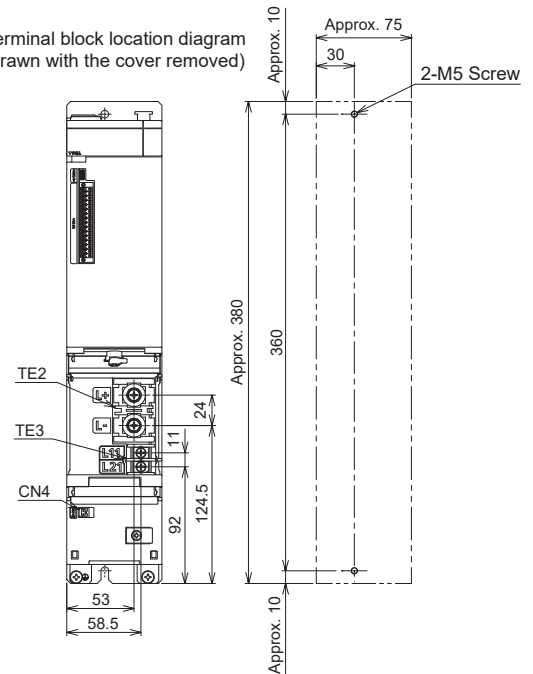

Mounting hole location diagram

Mounting screw
Screw size: M5
Tightening torque: 3.24 [N•m]

Terminal assignment

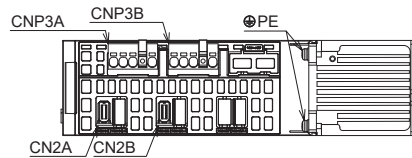
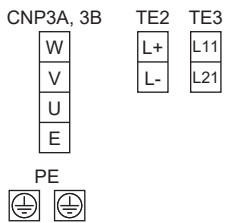

- TE2 Screw size: M6
Tightening torque: 3.0 [N•m]
- TE3 Screw size: M4
Tightening torque: 1.2 [N•m]
- PE Screw size: M5
Tightening torque: 2.0 [N•m]

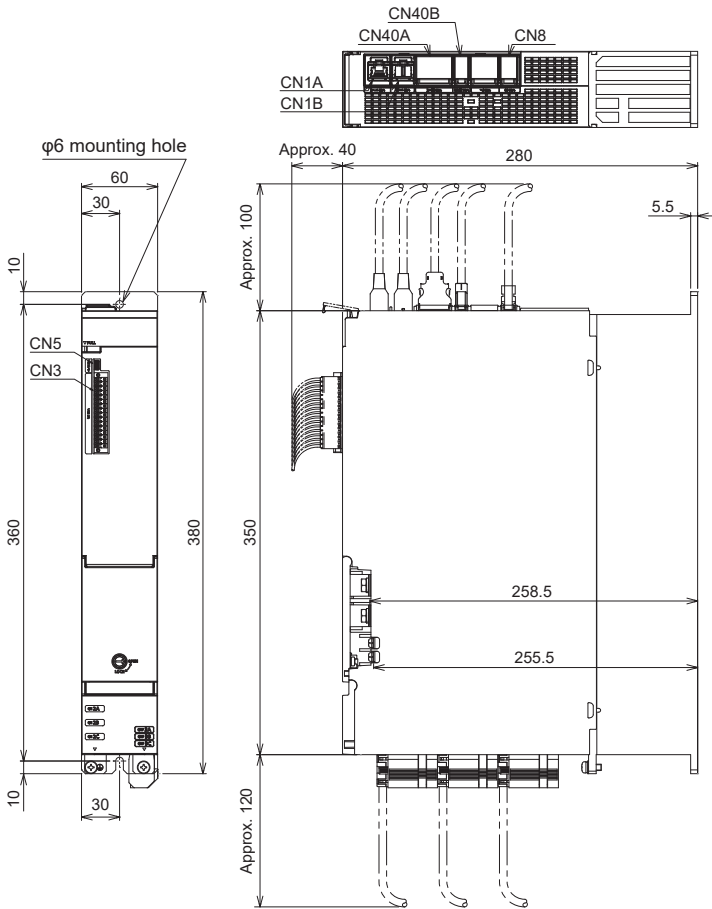

Terminal block location diagram (drawn with the cover removed)

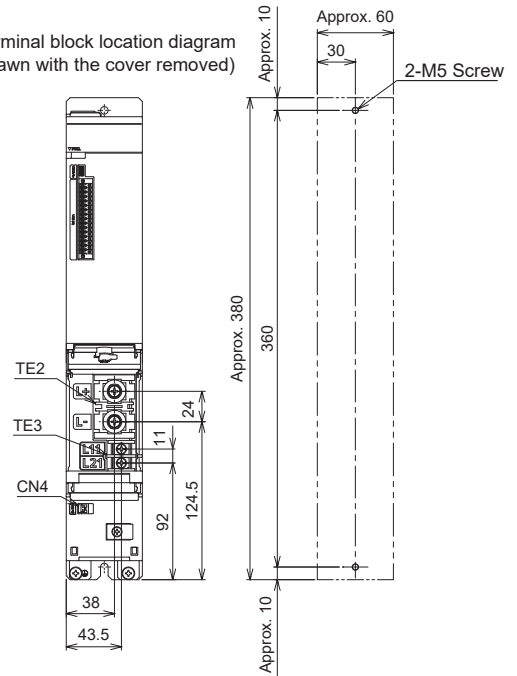

Mounting hole location diagram

Mounting screw
Screw size: M5
Tightening torque: 3.24 [N•m]

Terminal assignment

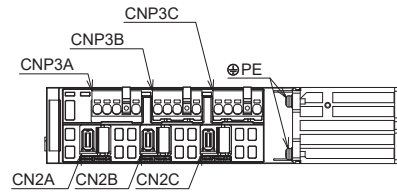
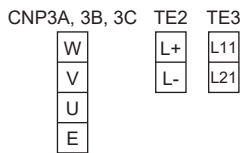

- TE2 Screw size: M6
Tightening torque: 3.0 [N•m]
- TE3 Screw size: M4
Tightening torque: 1.2 [N•m]
- PE Screw size: M5
Tightening torque: 2.0 [N•m]

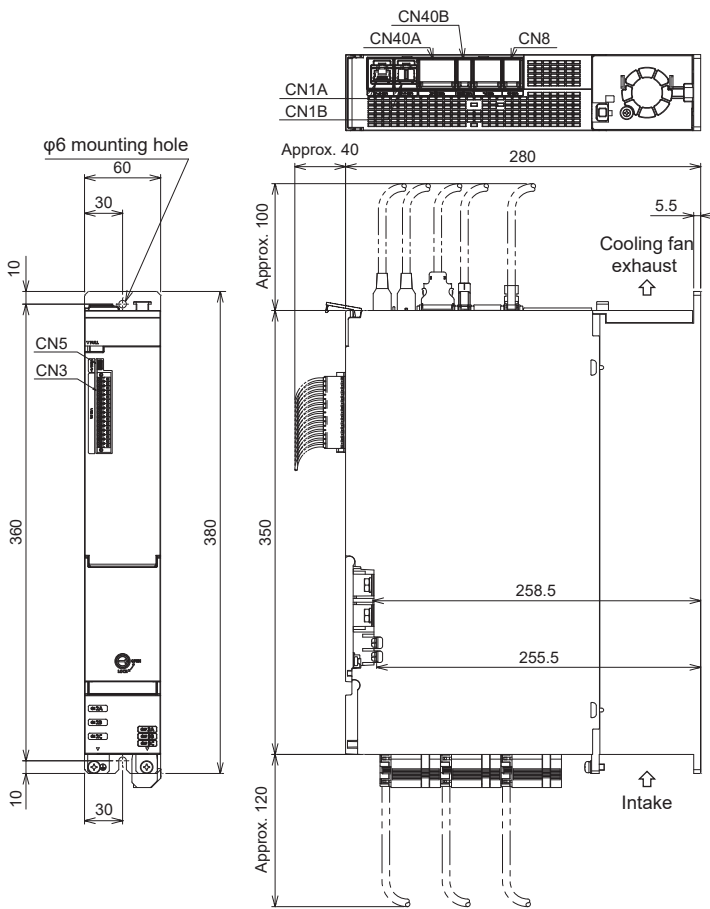

Terminal block location diagram (drawn with the cover removed)

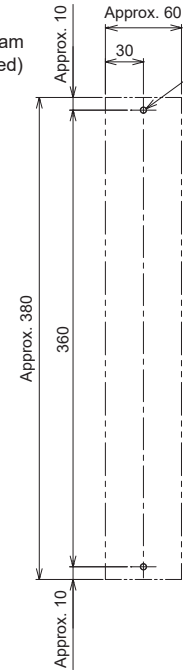
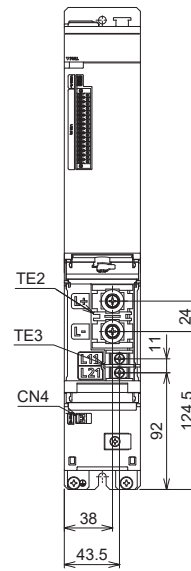

Mounting hole location diagram

Mounting screw
Screw size: M5
Tightening torque: 3.24 [N•m]

Terminal assignment

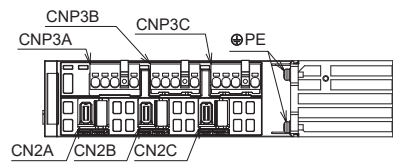
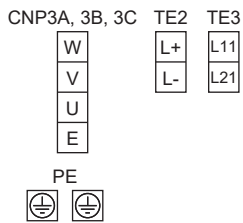

- TE2 Screw size: M6
Tightening torque: 3.0 [N•m]
- TE3 Screw size: M4
Tightening torque: 1.2 [N•m]
- PE Screw size: M5
Tightening torque: 2.0 [N•m]

4.2 Connector

Precautions

- Obtain the wiring instructions from the manufacturer and wire connectors appropriately.

CN3 connector

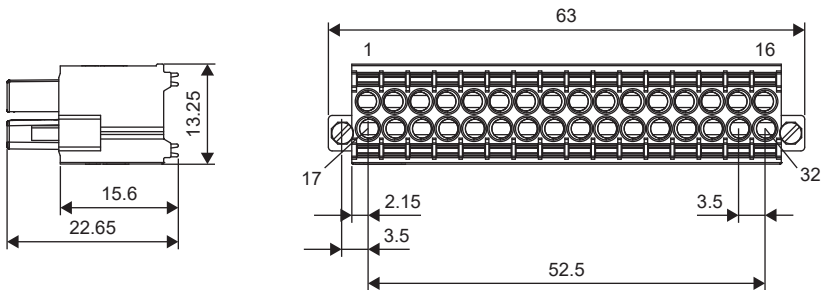

SCR connector system (3M)

Receptacle: 36210-0100PL

Shell kit: 36310-3200-008

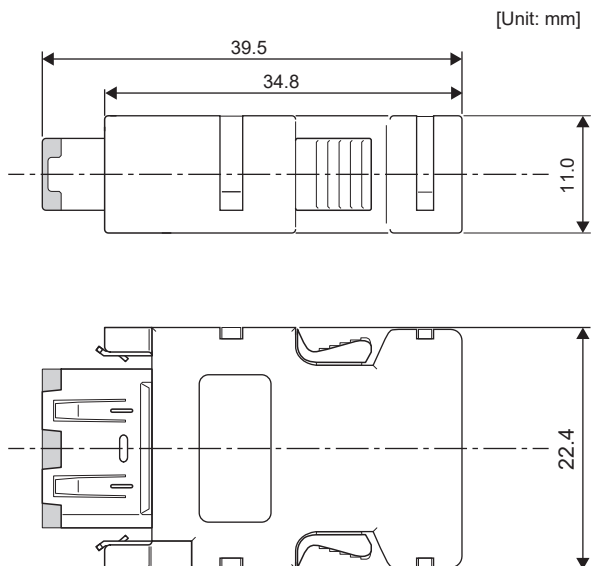

5 CHARACTERISTICS

5.1 Overload protection characteristics

Outline

An electronic thermal is built in the drive unit to protect the servo motor, drive unit and servo motor power wires from overloads. In this section, overload protection characteristics refer to the overload protection characteristics of drive units and servo motors.

[AL. 050 Overload 1] occurs if overload operation performed is above the electronic thermal protection curve shown below. [AL. 051 Overload 2] occurs if the maximum current is applied continuously for several seconds due to machine collision, etc. Use the equipment within the overload protection level indicated on the left side of the continuous or dotted lines in the following graphs.

For machines where unbalanced torque occurs, such as a vertical axis system, the unbalanced torque should be kept at 70 % or lower of the rated torque.

This drive unit has a servo motor overload protection function. (The servo motor overload current is set on the basis of 115 % rated current (full load current) of the drive unit.)

The drive unit may malfunction regardless of the electronic thermal protection if torque exceeding 100 % of the rated torque is generated too frequently while the servo motor is stopped (servo-lock status) or being operated at low speeds of 50 r/min or less.

Graph of overload protection characteristics

The following table lists servo motors and corresponding graphs of overload protection characteristics. The overload protection characteristics depend on the servo motor.

Rotary servo motor			Graph of overload protection characteristics
HK-KT	HK-ST	HK-RT	
053W 13W	—	—	☞ Page 93 Characteristic a
1M3W 434W 634W 7M34W 1034W 634UW 1034UW 1534W 2034W 2024W	524W 1024W 1724W 3024W 2024W 3524W 2024AW 3534W	1034W 1534W 2034W 3534W	☞ Page 93 Characteristic b
—	5024W 7024W 5034W	5034W 7034W	☞ Page 93 Characteristic c

Characteristic a

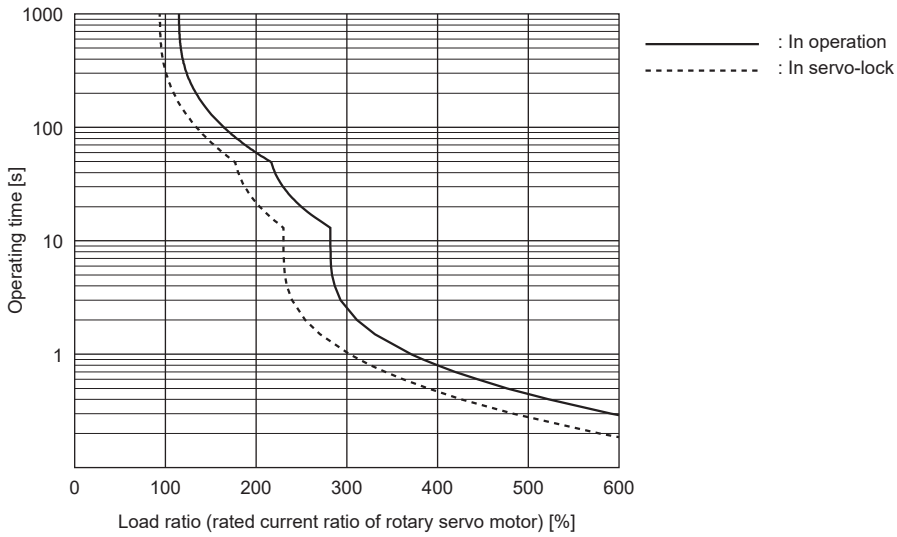

Characteristic b

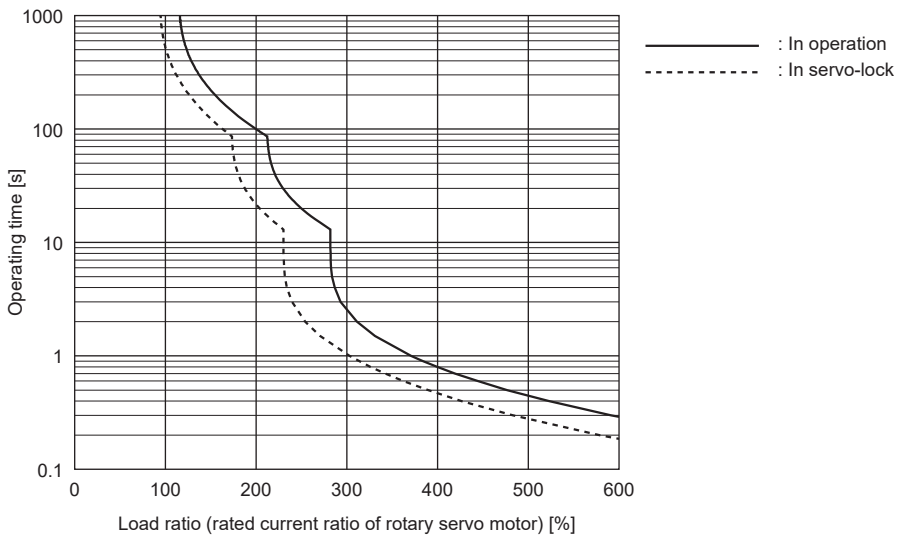

Characteristic c

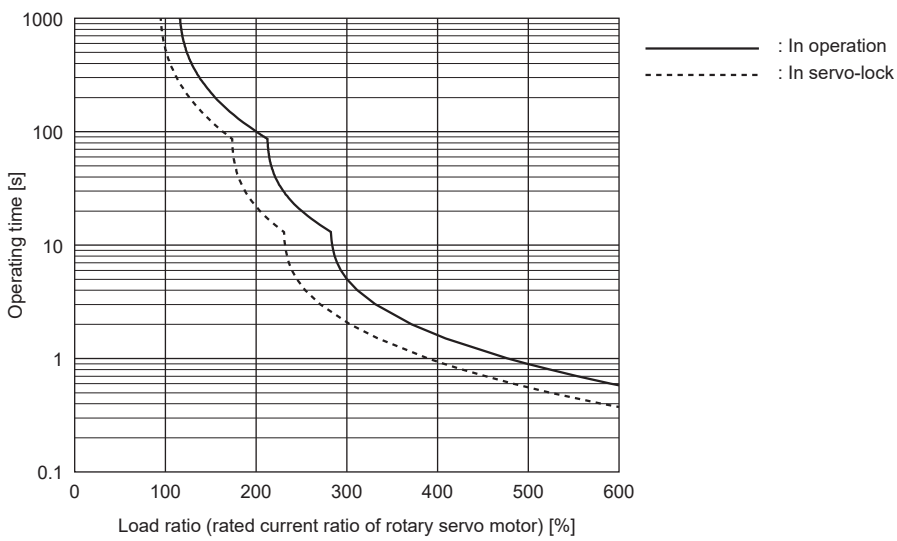

5.2 Power supply capacity and generated loss

Power supply capacity

Calculate the power supply capacity from the capacity of the converter unit.

MR-CV Power Regeneration Converter Unit User's Manual

Generated loss

Amount of heat generated by the drive unit

The following tables indicate the losses generated by drive units under rated load. For thermal design of an enclosed type cabinet, use the values in the tables in consideration for the harshest conditions with regard to the environment and operation pattern. The actual amount of generated heat depends on the frequency of operation and will be between the "At rated output" and "At servo-off" values.

■400 V class

- 1-axis drive unit

Drive unit	Drive unit generated heat [W]		Area required for heat dissipation [m ²]
	At rated output	At servo-off	
MR-J5D1-100_	100	30	2
MR-J5D1-200_	150	30	3
MR-J5D1-350_	210	30	4.2
MR-J5D1-500_	380	30	7.6
MR-J5D1-700_	450	30	9

- Multi-axis drive unit

Drive unit	Drive unit generated heat [W]		Area required for heat dissipation [m ²]
	At rated output	At servo-off	
MR-J5D2-100_	Connected to one axis: 100 Connected to two axes: 170	30	3.4
MR-J5D2-200_	Connected to one axis: 150 Connected to two axes: 270	30	5.4
MR-J5D2-350_	Connected to one axis: 210 Connected to two axes: 390	30	7.8
MR-J5D2-500_	Connected to one axis: 380 Connected to two axes: 730	30	14.6
MR-J5D2-700_	Connected to one axis: 450 Connected to two axes: 870	30	17.4
MR-J5D3-100_	Connected to one axis: 100 Connected to two axes: 170 Connected to three axes: 240	30	4.8
MR-J5D3-200_	Connected to one axis: 150 Connected to two axes: 270 Connected to three axes: 390	30	7.8

Heat dissipation area for enclosed type cabinet

For the heat dissipation area of the converter unit, refer to "Heat dissipation area for enclosed type cabinet" in the following manual.

📖 MR-CV Power Regeneration Converter Unit User's Manual

The enclosed type cabinet (hereafter called the cabinet) that stores the drive unit should be designed to ensure that its internal temperature rise is within +15 °C at an ambient temperature of 40 °C. Calculate the necessary heat dissipation area of the cabinet with the equation below (10.1) while allowing a margin of approximately 5 °C for a maximum ambient temperature of 60 °C.

$$A = \frac{P}{K \cdot \Delta T} \dots (10.1)$$

A: Heat dissipation area [m²]

P: Loss generated in the cabinet [W]

ΔT: Difference between internal and ambient temperatures [°C]

K: Heat dissipation coefficient [5 to 6]

When calculating the heat dissipation area with the equation (10.1), assume that P is the sum of all losses generated in the cabinet. For the amount of heat generated by the drive unit, refer to the following.

📖 Page 94 Amount of heat generated by the drive unit

"A" indicates the effective area for heat dissipation, but if the cabinet is directly installed on an insulated wall, that extra amount must be added to the cabinet's surface area. The required heat dissipation area will vary with the conditions in the cabinet. If convection in the cabinet is poor and heat builds up, effective heat dissipation will not be possible. Therefore, arrangement of the equipment in the cabinet and the use of a cooling fan should be considered. The following page contains information on the required heat dissipation area (estimated) of drive unit cabinets when operating amplifiers at a rated load in ambient temperatures of 40 °C.

📖 Page 94 Amount of heat generated by the drive unit

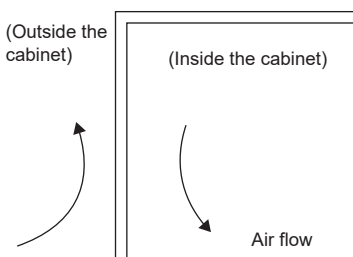

When air flows along the outer wall of the cabinet, effective heat exchange is possible, because the temperature slope inside and outside the cabinet is steeper.

5.3 Dynamic brake characteristics

Point

- The coasting distance is a theoretically calculated value that does not consider running loads such as friction. Since the coasting distance changes depending on the load moment of inertia, perform a test operation to check the actual braking distance. If the braking distance is long, a moving part may crash into the stroke end. Install an anti-crash mechanism such as an air brake or an electric/mechanical stopper such as a shock absorber to reduce the shock of moving parts.
- The dynamic brake is a function used to stop in an emergency and should not be used to stop during normal operations.
- For a machine operating at the recommended load to motor inertia ratio or less, the dynamic brake can be used approximately 1000 times if the dynamic brake is used to stop the motor from the rated speed once every 10 minutes.
- If using EM1 (Forced stop 1) frequently in non-emergency situations, enable EM1 (Forced stop 1) after the servo motor has come to a complete stop.
- Servo motors for MR-J5 may have the different coasting distance from that of the previous model.
- The time constant " τ " for the electronic dynamic brake will be shorter than that of the normal dynamic brake. Therefore, the coasting distance will be shorter than that of a normal dynamic brake. For how to set the electronic dynamic brake, refer to [Pr. PF06] and [Pr. PF12] in the following manual.
 MR-J5-G/MR-J5W-G User's Manual (Parameters)
- The MR-J5D_ drive unit has a different dynamic brake time constant from the MR-J5_ servo amplifier.

Precautions relating to the dynamic brake characteristics

The electronic dynamic brake operates in the initial state for the HK series servo motors listed below.

Series	Servo motor
HK-KT	HK-KT053W/HK-KT13W/HK-KT1M3W
HK-ST	HK-ST1024W

Dynamic brake operation

Calculation of coasting distance

The following figure shows the pattern in which the servo motor comes to a stop when the dynamic brake is operated. Use the equation (10.2) to calculate the approximate coasting distance to a stop. The dynamic brake time constant τ varies with the servo motor and machine operation speeds.

☞ Page 98 Dynamic brake time constant

A working part generally has a friction force. Therefore, the actual coasting distance will be shorter than the maximum coasting distance calculated with the following equation.

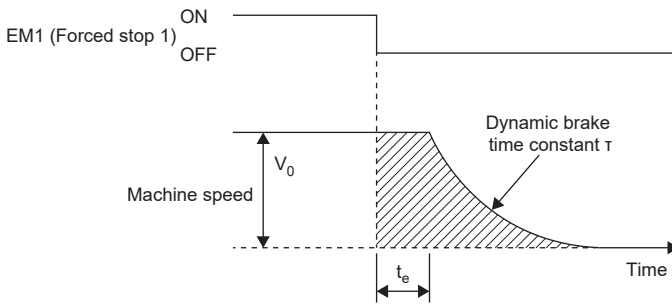

$$L_{\max} = \frac{V_0}{60} \cdot \left\{ t_e + \tau \left(1 + \frac{J_L}{J_M} \right) \right\} \dots (10.2)$$

L_{\max} : Maximum coasting distance [mm]

V_0 : Machine's fast feed speed [mm/min]

J_M : Moment of inertia of the servo motor [$\times 10^{-4}$ kg·m²]

J_L : Load moment of inertia converted into equivalent value on servo motor shaft [$\times 10^{-4}$ kg·m²]

τ : Dynamic brake time constant [s]

t_e : Delay time of control section [s]

There is an internal relay delay time of about 10 ms.

Dynamic brake time constant

The following shows dynamic brake time constant τ that is necessary to calculate the equation (10.2).

■400 V class

Servo motor	Drive unit	Waveform
HK-KT053W	MR-J5D_-100G4	
HK-KT13W	MR-J5D_-100G4	
HK-KT1M3W	MR-J5D_-100G4	
HK-KT434W	MR-J5D_-100G4 MR-J5D_-200G4	

Servo motor	Drive unit	Waveform																		
HK-KT634W	MR-J5D_-100G4 MR-J5D_-200G4	<table border="1"> <caption>Approximate data for HK-KT634W (MR-J5D_-100G4, MR-J5D_-200G4)</caption> <thead> <tr> <th>Servo motor speed [r/min]</th> <th>Dynamic brake time constant τ [ms]</th> </tr> </thead> <tbody> <tr><td>0</td><td>2.8</td></tr> <tr><td>1000</td><td>3.0</td></tr> <tr><td>2000</td><td>3.2</td></tr> <tr><td>3000</td><td>3.5</td></tr> <tr><td>4000</td><td>4.0</td></tr> <tr><td>5000</td><td>4.8</td></tr> <tr><td>6000</td><td>5.8</td></tr> <tr><td>7000</td><td>6.5</td></tr> </tbody> </table>	Servo motor speed [r/min]	Dynamic brake time constant τ [ms]	0	2.8	1000	3.0	2000	3.2	3000	3.5	4000	4.0	5000	4.8	6000	5.8	7000	6.5
	Servo motor speed [r/min]	Dynamic brake time constant τ [ms]																		
0	2.8																			
1000	3.0																			
2000	3.2																			
3000	3.5																			
4000	4.0																			
5000	4.8																			
6000	5.8																			
7000	6.5																			
MR-J5D_-350G4	<table border="1"> <caption>Approximate data for HK-KT634W (MR-J5D_-350G4)</caption> <thead> <tr> <th>Servo motor speed [r/min]</th> <th>Dynamic brake time constant τ [ms]</th> </tr> </thead> <tbody> <tr><td>0</td><td>1.8</td></tr> <tr><td>1000</td><td>2.0</td></tr> <tr><td>2000</td><td>2.5</td></tr> <tr><td>3000</td><td>3.2</td></tr> <tr><td>4000</td><td>4.2</td></tr> <tr><td>5000</td><td>5.5</td></tr> <tr><td>6000</td><td>7.0</td></tr> <tr><td>7000</td><td>7.5</td></tr> </tbody> </table>	Servo motor speed [r/min]	Dynamic brake time constant τ [ms]	0	1.8	1000	2.0	2000	2.5	3000	3.2	4000	4.2	5000	5.5	6000	7.0	7000	7.5	
Servo motor speed [r/min]	Dynamic brake time constant τ [ms]																			
0	1.8																			
1000	2.0																			
2000	2.5																			
3000	3.2																			
4000	4.2																			
5000	5.5																			
6000	7.0																			
7000	7.5																			
HK-KT7M34W	MR-J5D_-100G4 MR-J5D_-200G4	<table border="1"> <caption>Approximate data for HK-KT7M34W (MR-J5D_-100G4, MR-J5D_-200G4)</caption> <thead> <tr> <th>Servo motor speed [r/min]</th> <th>Dynamic brake time constant τ [ms]</th> </tr> </thead> <tbody> <tr><td>0</td><td>4.0</td></tr> <tr><td>1000</td><td>4.2</td></tr> <tr><td>2000</td><td>4.8</td></tr> <tr><td>3000</td><td>5.8</td></tr> <tr><td>4000</td><td>7.2</td></tr> <tr><td>5000</td><td>9.2</td></tr> <tr><td>6000</td><td>11.5</td></tr> <tr><td>7000</td><td>13.0</td></tr> </tbody> </table>	Servo motor speed [r/min]	Dynamic brake time constant τ [ms]	0	4.0	1000	4.2	2000	4.8	3000	5.8	4000	7.2	5000	9.2	6000	11.5	7000	13.0
	Servo motor speed [r/min]	Dynamic brake time constant τ [ms]																		
0	4.0																			
1000	4.2																			
2000	4.8																			
3000	5.8																			
4000	7.2																			
5000	9.2																			
6000	11.5																			
7000	13.0																			
MR-J5D_-350G4	<table border="1"> <caption>Approximate data for HK-KT7M34W (MR-J5D_-350G4)</caption> <thead> <tr> <th>Servo motor speed [r/min]</th> <th>Dynamic brake time constant τ [ms]</th> </tr> </thead> <tbody> <tr><td>0</td><td>2.5</td></tr> <tr><td>1000</td><td>3.0</td></tr> <tr><td>2000</td><td>4.0</td></tr> <tr><td>3000</td><td>5.5</td></tr> <tr><td>4000</td><td>7.8</td></tr> <tr><td>5000</td><td>11.0</td></tr> <tr><td>6000</td><td>14.5</td></tr> <tr><td>7000</td><td>16.5</td></tr> </tbody> </table>	Servo motor speed [r/min]	Dynamic brake time constant τ [ms]	0	2.5	1000	3.0	2000	4.0	3000	5.5	4000	7.8	5000	11.0	6000	14.5	7000	16.5	
Servo motor speed [r/min]	Dynamic brake time constant τ [ms]																			
0	2.5																			
1000	3.0																			
2000	4.0																			
3000	5.5																			
4000	7.8																			
5000	11.0																			
6000	14.5																			
7000	16.5																			

Servo motor	Drive unit	Waveform
HK-KT1034W	MR-J5D_-100G4 MR-J5D_-200G4	<p>Dynamic brake time constant τ [ms]</p> <p>Servo motor speed [r/min]</p>
	MR-J5D_-350G4	<p>Dynamic brake time constant τ [ms]</p> <p>Servo motor speed [r/min]</p>
HK-KT634UW	MR-J5D_-100G4 MR-J5D_-200G4	<p>Dynamic brake time constant τ [ms]</p> <p>Servo motor speed [r/min]</p>

Servo motor	Drive unit	Waveform
HK-KT1034UW	MR-J5D_-100G4 MR-J5D_-200G4	<p>Dynamic brake time constant τ [ms]</p> <p>Servo motor speed [r/min]</p>
	MR-J5D_-350G4	<p>Dynamic brake time constant τ [ms]</p> <p>Servo motor speed [r/min]</p>
HK-KT1534W	MR-J5D_-200G4	<p>Dynamic brake time constant τ [ms]</p> <p>Servo motor speed [r/min]</p>
	MR-J5D_-350G4	<p>Dynamic brake time constant τ [ms]</p> <p>Servo motor speed [r/min]</p>

Servo motor	Drive unit	Waveform
HK-KT2034W	MR-J5D_-200G4	
	MR-J5D_-350G4	
HK-KT2024W	MR-J5D_-200G4	
	MR-J5D_-350G4	

Servo motor	Drive unit	Waveform												
HK-ST524W	MR-J5D_-100G4 MR-J5D_-200G4	<table border="1"> <caption>Approximate data for HK-ST524W (MR-J5D_-100G4, MR-J5D_-200G4)</caption> <thead> <tr> <th>Servo motor speed [r/min]</th> <th>Dynamic brake time constant τ [ms]</th> </tr> </thead> <tbody> <tr><td>0</td><td>7</td></tr> <tr><td>1000</td><td>8</td></tr> <tr><td>2000</td><td>15</td></tr> <tr><td>3000</td><td>25</td></tr> <tr><td>4000</td><td>38</td></tr> </tbody> </table>	Servo motor speed [r/min]	Dynamic brake time constant τ [ms]	0	7	1000	8	2000	15	3000	25	4000	38
Servo motor speed [r/min]	Dynamic brake time constant τ [ms]													
0	7													
1000	8													
2000	15													
3000	25													
4000	38													
HK-ST1024W	MR-J5D_-100G4 MR-J5D_-200G4	<table border="1"> <caption>Approximate data for HK-ST1024W (MR-J5D_-100G4, MR-J5D_-200G4)</caption> <thead> <tr> <th>Servo motor speed [r/min]</th> <th>Dynamic brake time constant τ [ms]</th> </tr> </thead> <tbody> <tr><td>0</td><td>7</td></tr> <tr><td>1000</td><td>8</td></tr> <tr><td>2000</td><td>15</td></tr> <tr><td>3000</td><td>25</td></tr> <tr><td>4000</td><td>33</td></tr> </tbody> </table>	Servo motor speed [r/min]	Dynamic brake time constant τ [ms]	0	7	1000	8	2000	15	3000	25	4000	33
	Servo motor speed [r/min]	Dynamic brake time constant τ [ms]												
0	7													
1000	8													
2000	15													
3000	25													
4000	33													
	MR-J5D_-350G4	<table border="1"> <caption>Approximate data for HK-ST1024W (MR-J5D_-350G4)</caption> <thead> <tr> <th>Servo motor speed [r/min]</th> <th>Dynamic brake time constant τ [ms]</th> </tr> </thead> <tbody> <tr><td>0</td><td>5</td></tr> <tr><td>1000</td><td>6</td></tr> <tr><td>2000</td><td>15</td></tr> <tr><td>3000</td><td>25</td></tr> <tr><td>4000</td><td>45</td></tr> </tbody> </table>	Servo motor speed [r/min]	Dynamic brake time constant τ [ms]	0	5	1000	6	2000	15	3000	25	4000	45
Servo motor speed [r/min]	Dynamic brake time constant τ [ms]													
0	5													
1000	6													
2000	15													
3000	25													
4000	45													

Servo motor	Drive unit	Waveform												
HK-ST1724W	MR-J5D_-200G4	<table border="1"> <caption>Approximate data for MR-J5D_-200G4</caption> <thead> <tr> <th>Servo motor speed [r/min]</th> <th>Dynamic brake time constant τ [ms]</th> </tr> </thead> <tbody> <tr><td>0</td><td>9</td></tr> <tr><td>1000</td><td>10</td></tr> <tr><td>2000</td><td>13</td></tr> <tr><td>3000</td><td>18</td></tr> <tr><td>4000</td><td>27</td></tr> </tbody> </table>	Servo motor speed [r/min]	Dynamic brake time constant τ [ms]	0	9	1000	10	2000	13	3000	18	4000	27
	Servo motor speed [r/min]	Dynamic brake time constant τ [ms]												
0	9													
1000	10													
2000	13													
3000	18													
4000	27													
MR-J5D_-350G4 MR-J5D_-500G4	<table border="1"> <caption>Approximate data for MR-J5D_-350G4 and MR-J5D_-500G4</caption> <thead> <tr> <th>Servo motor speed [r/min]</th> <th>Dynamic brake time constant τ [ms]</th> </tr> </thead> <tbody> <tr><td>0</td><td>5</td></tr> <tr><td>1000</td><td>6</td></tr> <tr><td>2000</td><td>12</td></tr> <tr><td>3000</td><td>22</td></tr> <tr><td>4000</td><td>37</td></tr> </tbody> </table>	Servo motor speed [r/min]	Dynamic brake time constant τ [ms]	0	5	1000	6	2000	12	3000	22	4000	37	
Servo motor speed [r/min]	Dynamic brake time constant τ [ms]													
0	5													
1000	6													
2000	12													
3000	22													
4000	37													
HK-ST2024AW	MR-J5D_-200G4	<table border="1"> <caption>Approximate data for MR-J5D_-200G4</caption> <thead> <tr> <th>Servo motor speed [r/min]</th> <th>Dynamic brake time constant τ [ms]</th> </tr> </thead> <tbody> <tr><td>0</td><td>13</td></tr> <tr><td>1000</td><td>14</td></tr> <tr><td>2000</td><td>16</td></tr> <tr><td>3000</td><td>20</td></tr> <tr><td>4000</td><td>25</td></tr> </tbody> </table>	Servo motor speed [r/min]	Dynamic brake time constant τ [ms]	0	13	1000	14	2000	16	3000	20	4000	25
	Servo motor speed [r/min]	Dynamic brake time constant τ [ms]												
0	13													
1000	14													
2000	16													
3000	20													
4000	25													
MR-J5D_-350G4 MR-J5D_-500G4	<table border="1"> <caption>Approximate data for MR-J5D_-350G4 and MR-J5D_-500G4</caption> <thead> <tr> <th>Servo motor speed [r/min]</th> <th>Dynamic brake time constant τ [ms]</th> </tr> </thead> <tbody> <tr><td>0</td><td>7</td></tr> <tr><td>1000</td><td>8</td></tr> <tr><td>2000</td><td>13</td></tr> <tr><td>3000</td><td>20</td></tr> <tr><td>4000</td><td>29</td></tr> </tbody> </table>	Servo motor speed [r/min]	Dynamic brake time constant τ [ms]	0	7	1000	8	2000	13	3000	20	4000	29	
Servo motor speed [r/min]	Dynamic brake time constant τ [ms]													
0	7													
1000	8													
2000	13													
3000	20													
4000	29													

Servo motor	Drive unit	Waveform
HK-ST3024W	MR-J5D_-350G4 MR-J5D_-500G4	
	MR-J5D_-700G4	
HK-ST2024W	MR-J5D_-200G4	
	MR-J5D_-350G4 MR-J5D_-500G4	

Servo motor	Drive unit	Waveform												
HK-ST3524W	MR-J5D_-350G4 MR-J5D_-500G4	<table border="1"> <caption>Approximate data for MR-J5D_-350G4 and MR-J5D_-500G4</caption> <thead> <tr> <th>Servo motor speed [r/min]</th> <th>Dynamic brake time constant τ [ms]</th> </tr> </thead> <tbody> <tr><td>0</td><td>14</td></tr> <tr><td>1000</td><td>16</td></tr> <tr><td>2000</td><td>22</td></tr> <tr><td>3000</td><td>32</td></tr> <tr><td>3500</td><td>40</td></tr> </tbody> </table>	Servo motor speed [r/min]	Dynamic brake time constant τ [ms]	0	14	1000	16	2000	22	3000	32	3500	40
	Servo motor speed [r/min]	Dynamic brake time constant τ [ms]												
0	14													
1000	16													
2000	22													
3000	32													
3500	40													
MR-J5D_-700G4	<table border="1"> <caption>Approximate data for MR-J5D_-700G4</caption> <thead> <tr> <th>Servo motor speed [r/min]</th> <th>Dynamic brake time constant τ [ms]</th> </tr> </thead> <tbody> <tr><td>0</td><td>11</td></tr> <tr><td>1000</td><td>13</td></tr> <tr><td>2000</td><td>20</td></tr> <tr><td>3000</td><td>30</td></tr> <tr><td>3500</td><td>44</td></tr> </tbody> </table>	Servo motor speed [r/min]	Dynamic brake time constant τ [ms]	0	11	1000	13	2000	20	3000	30	3500	44	
Servo motor speed [r/min]	Dynamic brake time constant τ [ms]													
0	11													
1000	13													
2000	20													
3000	30													
3500	44													
HK-ST5024W	MR-J5D_-500G4	<table border="1"> <caption>Approximate data for MR-J5D_-500G4</caption> <thead> <tr> <th>Servo motor speed [r/min]</th> <th>Dynamic brake time constant τ [ms]</th> </tr> </thead> <tbody> <tr><td>0</td><td>25</td></tr> <tr><td>1000</td><td>26</td></tr> <tr><td>2000</td><td>30</td></tr> <tr><td>3000</td><td>36</td></tr> <tr><td>3800</td><td>43</td></tr> </tbody> </table>	Servo motor speed [r/min]	Dynamic brake time constant τ [ms]	0	25	1000	26	2000	30	3000	36	3800	43
	Servo motor speed [r/min]	Dynamic brake time constant τ [ms]												
0	25													
1000	26													
2000	30													
3000	36													
3800	43													
MR-J5D_-700G4	<table border="1"> <caption>Approximate data for MR-J5D_-700G4</caption> <thead> <tr> <th>Servo motor speed [r/min]</th> <th>Dynamic brake time constant τ [ms]</th> </tr> </thead> <tbody> <tr><td>0</td><td>19</td></tr> <tr><td>1000</td><td>20</td></tr> <tr><td>2000</td><td>25</td></tr> <tr><td>3000</td><td>32</td></tr> <tr><td>3800</td><td>43</td></tr> </tbody> </table>	Servo motor speed [r/min]	Dynamic brake time constant τ [ms]	0	19	1000	20	2000	25	3000	32	3800	43	
Servo motor speed [r/min]	Dynamic brake time constant τ [ms]													
0	19													
1000	20													
2000	25													
3000	32													
3800	43													

Servo motor	Drive unit	Waveform																		
HK-ST7024W	MR-J5D_-700G4	<table border="1"> <caption>Approximate data for HK-ST7024W</caption> <thead> <tr> <th>Servo motor speed [r/min]</th> <th>Dynamic brake time constant τ [ms]</th> </tr> </thead> <tbody> <tr><td>0</td><td>15</td></tr> <tr><td>500</td><td>16</td></tr> <tr><td>1000</td><td>18</td></tr> <tr><td>1500</td><td>21</td></tr> <tr><td>2000</td><td>24</td></tr> <tr><td>2500</td><td>28</td></tr> <tr><td>3000</td><td>32</td></tr> </tbody> </table>	Servo motor speed [r/min]	Dynamic brake time constant τ [ms]	0	15	500	16	1000	18	1500	21	2000	24	2500	28	3000	32		
Servo motor speed [r/min]	Dynamic brake time constant τ [ms]																			
0	15																			
500	16																			
1000	18																			
1500	21																			
2000	24																			
2500	28																			
3000	32																			
HK-ST3534W	MR-J5D_-350G4 MR-J5D_-500G4	<table border="1"> <caption>Approximate data for HK-ST3534W</caption> <thead> <tr> <th>Servo motor speed [r/min]</th> <th>Dynamic brake time constant τ [ms]</th> </tr> </thead> <tbody> <tr><td>0</td><td>13</td></tr> <tr><td>1000</td><td>14</td></tr> <tr><td>2000</td><td>17</td></tr> <tr><td>3000</td><td>22</td></tr> <tr><td>4000</td><td>28</td></tr> <tr><td>5000</td><td>35</td></tr> <tr><td>6000</td><td>42</td></tr> <tr><td>7000</td><td>45</td></tr> </tbody> </table>	Servo motor speed [r/min]	Dynamic brake time constant τ [ms]	0	13	1000	14	2000	17	3000	22	4000	28	5000	35	6000	42	7000	45
Servo motor speed [r/min]	Dynamic brake time constant τ [ms]																			
0	13																			
1000	14																			
2000	17																			
3000	22																			
4000	28																			
5000	35																			
6000	42																			
7000	45																			
HK-ST5034W	MR-J5D_-500G4	<table border="1"> <caption>Approximate data for HK-ST5034W (MR-J5D_-500G4)</caption> <thead> <tr> <th>Servo motor speed [r/min]</th> <th>Dynamic brake time constant τ [ms]</th> </tr> </thead> <tbody> <tr><td>0</td><td>16</td></tr> <tr><td>1000</td><td>17</td></tr> <tr><td>2000</td><td>19</td></tr> <tr><td>3000</td><td>23</td></tr> <tr><td>4000</td><td>28</td></tr> <tr><td>5000</td><td>33</td></tr> <tr><td>6000</td><td>35</td></tr> </tbody> </table>	Servo motor speed [r/min]	Dynamic brake time constant τ [ms]	0	16	1000	17	2000	19	3000	23	4000	28	5000	33	6000	35		
	Servo motor speed [r/min]	Dynamic brake time constant τ [ms]																		
0	16																			
1000	17																			
2000	19																			
3000	23																			
4000	28																			
5000	33																			
6000	35																			
	MR-J5D_-700G4	<table border="1"> <caption>Approximate data for HK-ST5034W (MR-J5D_-700G4)</caption> <thead> <tr> <th>Servo motor speed [r/min]</th> <th>Dynamic brake time constant τ [ms]</th> </tr> </thead> <tbody> <tr><td>0</td><td>12</td></tr> <tr><td>1000</td><td>13</td></tr> <tr><td>2000</td><td>16</td></tr> <tr><td>3000</td><td>21</td></tr> <tr><td>4000</td><td>27</td></tr> <tr><td>5000</td><td>33</td></tr> <tr><td>6000</td><td>38</td></tr> </tbody> </table>	Servo motor speed [r/min]	Dynamic brake time constant τ [ms]	0	12	1000	13	2000	16	3000	21	4000	27	5000	33	6000	38		
Servo motor speed [r/min]	Dynamic brake time constant τ [ms]																			
0	12																			
1000	13																			
2000	16																			
3000	21																			
4000	27																			
5000	33																			
6000	38																			

Servo motor	Drive unit	Waveform																		
HK-RT1034W	MR-J5D_-100G4 MR-J5D_-200G4	<table border="1"> <caption>Approximate data for HK-RT1034W</caption> <thead> <tr> <th>Servo motor speed [r/min]</th> <th>Dynamic brake time constant τ [ms]</th> </tr> </thead> <tbody> <tr><td>0</td><td>1.5</td></tr> <tr><td>1000</td><td>2.0</td></tr> <tr><td>2000</td><td>3.0</td></tr> <tr><td>3000</td><td>4.5</td></tr> <tr><td>4000</td><td>7.0</td></tr> <tr><td>5000</td><td>10.0</td></tr> <tr><td>6000</td><td>14.0</td></tr> <tr><td>7000</td><td>16.5</td></tr> </tbody> </table>	Servo motor speed [r/min]	Dynamic brake time constant τ [ms]	0	1.5	1000	2.0	2000	3.0	3000	4.5	4000	7.0	5000	10.0	6000	14.0	7000	16.5
Servo motor speed [r/min]	Dynamic brake time constant τ [ms]																			
0	1.5																			
1000	2.0																			
2000	3.0																			
3000	4.5																			
4000	7.0																			
5000	10.0																			
6000	14.0																			
7000	16.5																			
HK-RT1534W	MR-J5D_-200G4	<table border="1"> <caption>Approximate data for HK-RT1534W (MR-J5D_-200G4)</caption> <thead> <tr> <th>Servo motor speed [r/min]</th> <th>Dynamic brake time constant τ [ms]</th> </tr> </thead> <tbody> <tr><td>0</td><td>2.5</td></tr> <tr><td>1000</td><td>2.8</td></tr> <tr><td>2000</td><td>3.5</td></tr> <tr><td>3000</td><td>4.5</td></tr> <tr><td>4000</td><td>6.0</td></tr> <tr><td>5000</td><td>8.0</td></tr> <tr><td>6000</td><td>11.0</td></tr> <tr><td>7000</td><td>14.0</td></tr> </tbody> </table>	Servo motor speed [r/min]	Dynamic brake time constant τ [ms]	0	2.5	1000	2.8	2000	3.5	3000	4.5	4000	6.0	5000	8.0	6000	11.0	7000	14.0
	Servo motor speed [r/min]	Dynamic brake time constant τ [ms]																		
0	2.5																			
1000	2.8																			
2000	3.5																			
3000	4.5																			
4000	6.0																			
5000	8.0																			
6000	11.0																			
7000	14.0																			
	MR-J5D_-500G4	<table border="1"> <caption>Approximate data for HK-RT1534W (MR-J5D_-500G4)</caption> <thead> <tr> <th>Servo motor speed [r/min]</th> <th>Dynamic brake time constant τ [ms]</th> </tr> </thead> <tbody> <tr><td>0</td><td>1.5</td></tr> <tr><td>1000</td><td>2.0</td></tr> <tr><td>2000</td><td>3.0</td></tr> <tr><td>3000</td><td>4.5</td></tr> <tr><td>4000</td><td>7.0</td></tr> <tr><td>5000</td><td>10.0</td></tr> <tr><td>6000</td><td>13.0</td></tr> <tr><td>7000</td><td>16.5</td></tr> </tbody> </table>	Servo motor speed [r/min]	Dynamic brake time constant τ [ms]	0	1.5	1000	2.0	2000	3.0	3000	4.5	4000	7.0	5000	10.0	6000	13.0	7000	16.5
Servo motor speed [r/min]	Dynamic brake time constant τ [ms]																			
0	1.5																			
1000	2.0																			
2000	3.0																			
3000	4.5																			
4000	7.0																			
5000	10.0																			
6000	13.0																			
7000	16.5																			

Servo motor	Drive unit	Waveform																		
HK-RT2034W	MR-J5D_-200G4	<table border="1"> <caption>Approximate data for MR-J5D_-200G4</caption> <thead> <tr> <th>Servo motor speed [r/min]</th> <th>Dynamic brake time constant τ [ms]</th> </tr> </thead> <tbody> <tr><td>0</td><td>1.8</td></tr> <tr><td>1000</td><td>2.2</td></tr> <tr><td>2000</td><td>2.8</td></tr> <tr><td>3000</td><td>3.8</td></tr> <tr><td>4000</td><td>5.2</td></tr> <tr><td>5000</td><td>7.0</td></tr> <tr><td>6000</td><td>9.0</td></tr> <tr><td>6500</td><td>9.5</td></tr> </tbody> </table>	Servo motor speed [r/min]	Dynamic brake time constant τ [ms]	0	1.8	1000	2.2	2000	2.8	3000	3.8	4000	5.2	5000	7.0	6000	9.0	6500	9.5
Servo motor speed [r/min]	Dynamic brake time constant τ [ms]																			
0	1.8																			
1000	2.2																			
2000	2.8																			
3000	3.8																			
4000	5.2																			
5000	7.0																			
6000	9.0																			
6500	9.5																			
	MR-J5D_-350G4	<table border="1"> <caption>Approximate data for MR-J5D_-350G4</caption> <thead> <tr> <th>Servo motor speed [r/min]</th> <th>Dynamic brake time constant τ [ms]</th> </tr> </thead> <tbody> <tr><td>0</td><td>1.0</td></tr> <tr><td>1000</td><td>1.5</td></tr> <tr><td>2000</td><td>2.5</td></tr> <tr><td>3000</td><td>4.0</td></tr> <tr><td>4000</td><td>6.0</td></tr> <tr><td>5000</td><td>9.0</td></tr> <tr><td>6000</td><td>13.0</td></tr> <tr><td>6500</td><td>15.5</td></tr> </tbody> </table>	Servo motor speed [r/min]	Dynamic brake time constant τ [ms]	0	1.0	1000	1.5	2000	2.5	3000	4.0	4000	6.0	5000	9.0	6000	13.0	6500	15.5
Servo motor speed [r/min]	Dynamic brake time constant τ [ms]																			
0	1.0																			
1000	1.5																			
2000	2.5																			
3000	4.0																			
4000	6.0																			
5000	9.0																			
6000	13.0																			
6500	15.5																			
HK-RT3534W	MR-J5D_-350G4 MR-J5D_-500G4	<table border="1"> <caption>Approximate data for MR-J5D_-350G4 and MR-J5D_-500G4</caption> <thead> <tr> <th>Servo motor speed [r/min]</th> <th>Dynamic brake time constant τ [ms]</th> </tr> </thead> <tbody> <tr><td>0</td><td>2.5</td></tr> <tr><td>1000</td><td>3.0</td></tr> <tr><td>2000</td><td>4.0</td></tr> <tr><td>3000</td><td>5.5</td></tr> <tr><td>4000</td><td>8.0</td></tr> <tr><td>5000</td><td>11.0</td></tr> <tr><td>6000</td><td>14.5</td></tr> </tbody> </table>	Servo motor speed [r/min]	Dynamic brake time constant τ [ms]	0	2.5	1000	3.0	2000	4.0	3000	5.5	4000	8.0	5000	11.0	6000	14.5		
Servo motor speed [r/min]	Dynamic brake time constant τ [ms]																			
0	2.5																			
1000	3.0																			
2000	4.0																			
3000	5.5																			
4000	8.0																			
5000	11.0																			
6000	14.5																			

Servo motor	Drive unit	Waveform																
HK-RT5034W	MR-J5D_-500G4	<table border="1"> <caption>Data for MR-J5D_-500G4</caption> <thead> <tr> <th>Servo motor speed [r/min]</th> <th>Dynamic brake time constant τ [ms]</th> </tr> </thead> <tbody> <tr><td>0</td><td>4.5</td></tr> <tr><td>1000</td><td>4.8</td></tr> <tr><td>2000</td><td>5.2</td></tr> <tr><td>3000</td><td>6.0</td></tr> <tr><td>4000</td><td>7.2</td></tr> <tr><td>5000</td><td>8.8</td></tr> <tr><td>6000</td><td>11.0</td></tr> </tbody> </table>	Servo motor speed [r/min]	Dynamic brake time constant τ [ms]	0	4.5	1000	4.8	2000	5.2	3000	6.0	4000	7.2	5000	8.8	6000	11.0
Servo motor speed [r/min]	Dynamic brake time constant τ [ms]																	
0	4.5																	
1000	4.8																	
2000	5.2																	
3000	6.0																	
4000	7.2																	
5000	8.8																	
6000	11.0																	
	MR-J5D_-700G4	<table border="1"> <caption>Data for MR-J5D_-700G4</caption> <thead> <tr> <th>Servo motor speed [r/min]</th> <th>Dynamic brake time constant τ [ms]</th> </tr> </thead> <tbody> <tr><td>0</td><td>3.5</td></tr> <tr><td>1000</td><td>3.8</td></tr> <tr><td>2000</td><td>4.5</td></tr> <tr><td>3000</td><td>5.5</td></tr> <tr><td>4000</td><td>7.0</td></tr> <tr><td>5000</td><td>9.0</td></tr> <tr><td>6000</td><td>12.0</td></tr> </tbody> </table>	Servo motor speed [r/min]	Dynamic brake time constant τ [ms]	0	3.5	1000	3.8	2000	4.5	3000	5.5	4000	7.0	5000	9.0	6000	12.0
Servo motor speed [r/min]	Dynamic brake time constant τ [ms]																	
0	3.5																	
1000	3.8																	
2000	4.5																	
3000	5.5																	
4000	7.0																	
5000	9.0																	
6000	12.0																	
HK-RT7034W	MR-J5D_-700G4	<table border="1"> <caption>Data for MR-J5D_-700G4 (HK-RT7034W)</caption> <thead> <tr> <th>Servo motor speed [r/min]</th> <th>Dynamic brake time constant τ [ms]</th> </tr> </thead> <tbody> <tr><td>0</td><td>2.8</td></tr> <tr><td>1000</td><td>3.0</td></tr> <tr><td>2000</td><td>3.8</td></tr> <tr><td>3000</td><td>5.0</td></tr> <tr><td>4000</td><td>6.8</td></tr> <tr><td>5000</td><td>9.5</td></tr> </tbody> </table>	Servo motor speed [r/min]	Dynamic brake time constant τ [ms]	0	2.8	1000	3.0	2000	3.8	3000	5.0	4000	6.8	5000	9.5		
Servo motor speed [r/min]	Dynamic brake time constant τ [ms]																	
0	2.8																	
1000	3.0																	
2000	3.8																	
3000	5.0																	
4000	6.8																	
5000	9.5																	

Permissible load to motor inertia when the dynamic brake is used

Use the dynamic brake under the load to motor inertia ratio indicated in the following table. If the ratio is higher than this value, the dynamic brake may burn. If the ratio exceeds the value, contact your local sales office.

The values of the permissible load to motor inertia ratio in the table are the values at the maximum speed of the servo motor.

■400 V class

Series	Model	Permissible load to motor inertia ratio [multiplier]
HK-KT	HK-KT053W	34
	HK-KT13W	34
	HK-KT1M3W	34
	HK-KT434W	37
	HK-KT634W	37
	HK-KT7M34W	37
	HK-KT1034W	33
	HK-KT634UW	27
	HK-KT1034UW	24
	HK-KT1534W	10
	HK-KT2034W	9
	HK-KT2024W	29
	HK-ST	HK-ST524W
HK-ST1024W		16
HK-ST1724W		11
HK-ST2024AW		7 (when 2000 r/min or less: 29)
HK-ST3024W		28
HK-ST2024W		2 (when 2000 r/min or less: 12)
HK-ST3524W		4 (when 2000 r/min or less: 14)
HK-ST5024W		2 (when 2000 r/min or less: 10)
HK-ST7024W		2 (when 2000 r/min or less: 7)
HK-ST3534W		3 (when 3000 r/min or less: 20)
HK-ST5034W		2 (when 3000 r/min or less: 12)
HK-RT	HK-RT1034W	67
	HK-RT1534W	45
	HK-RT2034W	34
	HK-RT3534W	19
	HK-RT5034W	13
	HK-RT7034W	16

5.4 Cable flex life

The flex life of the cables is shown below. This graph shows calculated values and not guaranteed values. The cable flex life factors in conductor and insulation breakage. The values are calculated from fully disconnected cables and do not take into account wear from electrical characteristics, sheath abrasion, or insulation deterioration. Allow for some deviation in these values.

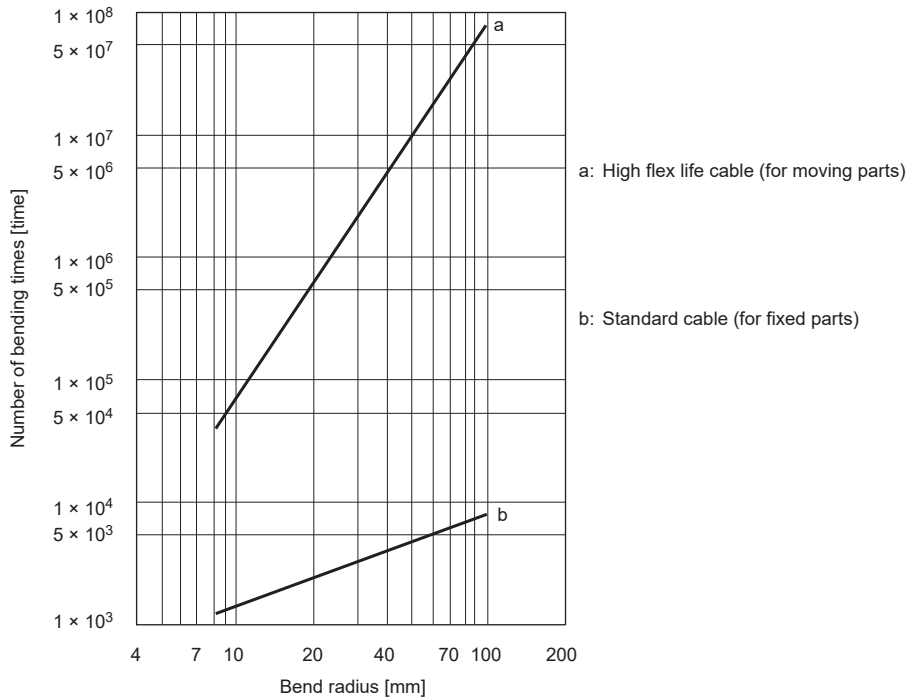

5.5 Inrush currents at power-on of control circuit

A molded-case circuit breaker and magnetic contactor may fail or malfunction due to an inrush current flowing through the drive unit's power lines (input lines) at power-on. Therefore, use products with the specifications described on the following page.

☞ Page 123 Molded-case circuit breakers, fuses

When circuit protectors are used, it is recommended that the inertia delay type, which is not tripped by an inrush current, be used.

400 V class

The following shows the inrush currents (reference data) that will flow when 480 V AC is applied.

Drive unit	Inrush currents (A_{0-P})
	Control circuit power supply (L11/L21)
MR-J5D_	16 A (attenuated to approx. 2 A in 30 ms)

6 OPTIONS AND PERIPHERAL EQUIPMENT

Precautions

- HIV wires are recommended to wire the drive units, options, and peripheral equipment. Therefore, the recommended wire sizes may differ from those used for previous generation drive units.
- To prevent an electric shock or a fire, correctly wire options and peripheral equipment, etc. in the correct combination.

6.1 Cables/connector sets

Point

The indicated IP rating is the cable and connector's protection against ingress of dust and water when the cable and connector are connected to a drive unit and servo motor. If the IP ratings of the cables, connectors, drive unit, and servo motor differ, the overall IP rating is determined by the lowest IP rating of all the components.

Purchase the cable and connector options indicated in this section for this drive unit.

Use the cables provided by Mitsubishi Electric and Mitsubishi Electric System & Service Co., Ltd. When fabricating a cable, select a wire suitable for the application. As an example of selecting a power cable suitable for the application, the 2018 edition of NFPA 79 in North America demands the use of a listed, certified product that has a thermoset insulator and is compliant with the NEC standard RHH, RHW, RHW-2, XHH, XHHW, or XHHW-2.

For information on options for servo motor power supplies, electromagnetic brakes, servo motor encoders, and load-side encoders, refer to "WIRING OPTION" in the following manual.

 Rotary Servo Motor User's Manual (HK series)

For options for linear encoders, refer to "OPTION CABLES/CONNECTOR SETS" in the following manual.

 MR-J5 Partner's Encoder User's Manual

Combinations of cables/connector sets

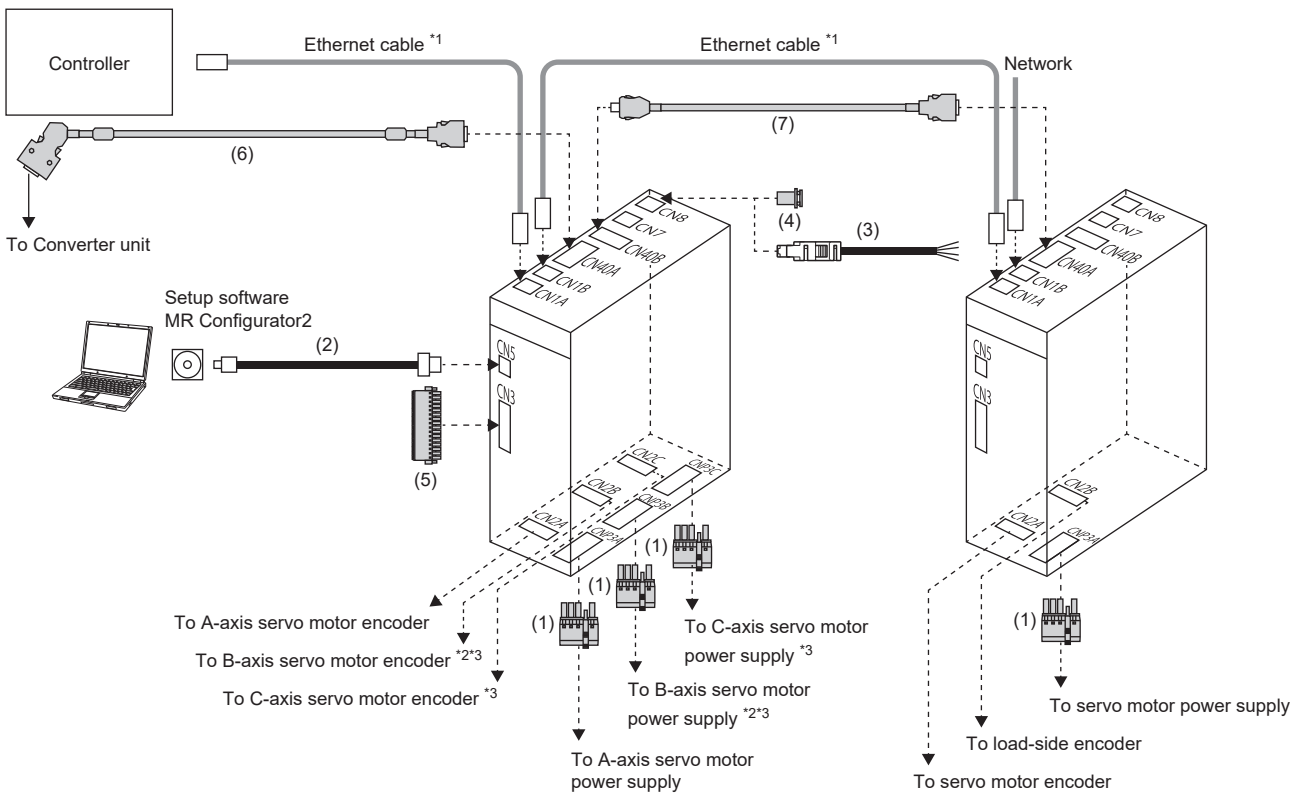





*1 Refer to the following page for information on Ethernet cable specifications.

☞ Page 118 Ethernet cable

*2 For 2-axis drive units.

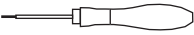
*3 For 3-axis drive units.

List of cables/connector sets

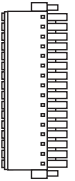
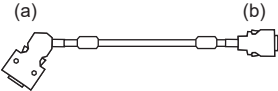
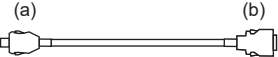
No.	Product name	Model	Description	Remark
(1)	Drive unit power connector	—	 <p>CNP3_ connector BVF 7.62HP/04/180MF4 SN BK BX LRP (Weidmüller) Applicable wire size: 0.5 mm² to 10 mm² (AWG 24 to 8)</p>	Supplied with the drive unit
			 <p>Open tool: SDS 0.8X4.5X125 (Weidmüller)</p>	Not included with the drive unit. Purchase it separately.
(2)	USB cable	MR-J3USBCBL3M cable length: 3 m	 <p>(a) CN5 connector: mini-B connector (5 pins) (b) Personal computer connector: Connector A</p>	For connection with a personal computer
(3)	STO cable	MR-D05UDL3M-B	 <p>(a) Connector set: 2069250-1 (TE Connectivity)</p>	Connection cable for the CN8 connector
(4)	Short-circuit connector	—		Supplied with the drive unit
(5)	I/O and monitor connector	MR-ADCN3	 <p>CN3 connector DFMC1,5/16-STF-3,5 (Phoenix Contact)</p>	With pin number printing
(6)	Protection coordination cable	MR-ACDL_M Cable length: 0.2 m/ 0.5 m	 <p>(a) Plug: 10120-3000PE Shell kit: 10320-56F0-008 (3M or equivalent) (b) Plug: HDR-E26MG1+ Shell kit: HDR-E26LPJP+ (Honda Tsushin Kogyo)</p>	For connection of the converter unit and drive unit
(7)	Protection coordination cable	MR-ADDL02M Cable length: 0.2 m	 <p>(a) Connector: IX30G-A-10S-CV(7.0) (Hirose Electric) (b) Plug: HDR-E26MG1+ Shell kit: HDR-E26LPJP+ (Honda Tsushin Kogyo)</p>	For connection between drive units

MR-D05UDL3M-B STO cable

This cable is for connecting an external device to the CN8 connector.

Cable model	Cable length	Cable OD ^{*1}	Application
MR-D05UDL3M-B	3 m	5.7 mm	Connection cable for the CN8 connector

*1 Standard OD. The maximum OD is about 10 % greater for dimensions without tolerances.

System architecture

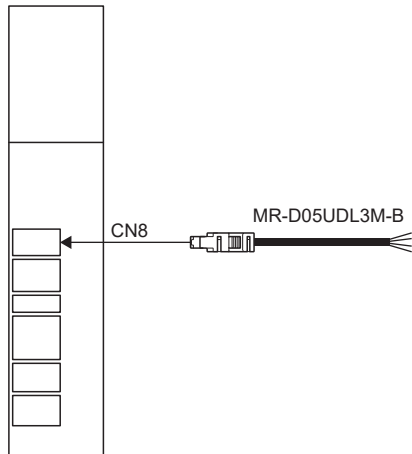

Top view of drive unit

Internal wiring diagram

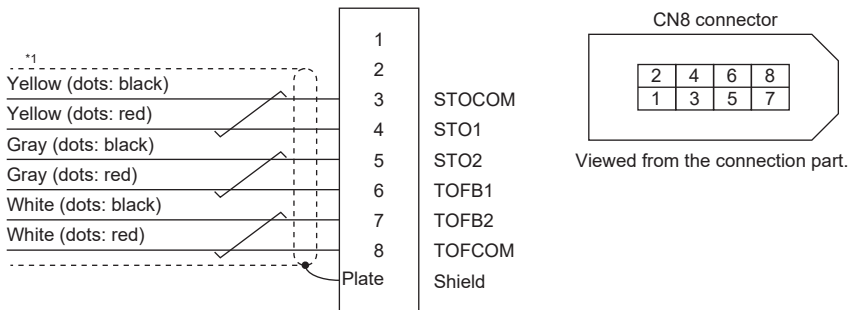

*1 Do not use the two core wires with orange insulators (with red or black dots).

Ethernet cable

For Ethernet cables used for network wiring, refer to "Communication specifications" in the User's Manual (Communication Function).

A commercially available product example is as follows.

Product name		Model	Specifications	
Ethernet cable	For indoor use	SC-E5EW-S_M	_: cable length (0.5 m, 1 to 100 m (unit: 1 m))	Double shielded cable (category 5e)
	For moving parts (indoor use)	SC-E5EW-S_M-MV	_: cable length (0.1 m, 0.2 m, 0.3 m, 0.5 m, 1 to 45 m (unit: 1 m))	
	For indoor/outdoor use	SC-E5EW-S_M-L	_: cable length (1 to 100 m (Unit: 1 m))	

For commercially available cables other than the above, refer to the CC-Link Partner Association website.

<https://www.cc-link.org/en/>

Precautions

- When branching the CC-Link IE TSN network using a switching hub, use a switching hub (Class B) that is recommended by the CC-Link Partner Association. Although a switching hub (Class A) can also be used, there are restrictions on the type of topology that can be used. For further information, refer to "MELSEC iQ-R Motion Module User's Manual (Startup)".
- When branching the CC-Link IE Field Network Basic network using a switching hub, use a hub with a transmission speed of 100 Mbps or higher. For switching hubs that do not have the auto-negotiation function, set the transmission speed to 100 Mbps and half-duplex.

Bus bar

Use a bus bar to connect the L+/L- terminals between the converter unit and the drive unit, and between the drive units. The bus bar to be used is different depending on the width and arrangement of the power regeneration converter unit or the drive unit to be connected.

Bus bar selection list

Left side unit *1	Right side unit *1	Bus bar model	Number of packages per set
MR-CV11K4 MR-CV18K4	MR-J5D1_ MR-J5D2-100G4 MR-J5D2-200G4 MR-J5D2-350G4 MR-J5D3_	MR-DCBAR077-B02	2
	MR-J5D2-500G4 MR-J5D2-700G4	MR-DCBAR092-B02	2
MR-CV30K4 MR-CV37K4 MR-CV45K4	MR-J5D1_ MR-J5D2-100G4 MR-J5D2-200G4 MR-J5D2-350G4 MR-J5D3_	MR-DCBAR097-B02	2
	MR-J5D2-500G4 MR-J5D2-700G4	MR-DCBAR112-B02	2
MR-CV55K4 MR-CV75K4	MR-J5D1_ MR-J5D2-100G4 MR-J5D2-200G4 MR-J5D2-350G4 MR-J5D3_	MR-DCBAR099-B03	2
	MR-J5D2-500G4 MR-J5D2-700G4	MR-DCBAR114-B03	2
MR-J5D1_ MR-J5D2_ MR-J5D3_	MR-J5D1_ MR-J5D2-100G4 MR-J5D2-200G4 MR-J5D2-350G4 MR-J5D3_	MR-DCBAR077-B02	2
	MR-J5D2-500G4 MR-J5D2-700G4	MR-DCBAR092-B02	2

*1 The left and right indicate the positional relationship when the unit is viewed from the front.

Adjustment bar

If the number of drive units connected to the power regeneration converter unit is an even number, there will be a gap between the bus bar of the drive unit at the far end (right end) and the TE2 terminal block by the thickness of the conductor. Therefore, overlap and screw the adjustment bar (MR-DCBAR024-B05).

 Page 47 How to use the bus bar

Bus bar	Number of packages per set
MR-DCBAR024-B05	2

6.2 MR Configurator2

Engineering tool

MR Configurator2 (SW1DNC-MRC2-_) can be used with this drive unit.

For the engineering tool specifications and system configuration, refer to the installation guide of the engineering tool.

Precautions for using USB communication function and Ethernet communication function

Note the following to prevent an electric shock or malfunction of the drive unit.

Connecting the power of a personal computer

Connect the power of a personal computer with the following procedure.

■When using a personal computer with an AC power supply

- When using a personal computer with a three-core power plug or a power plug with a grounding wire, use a three-pin socket or ground the grounding wire.
- When your personal computer has a two-core power plug and has no grounding wire, connect the personal computer to the drive unit with the following procedure.

1. Disconnect the power plug of the personal computer from the AC power socket.
2. Check that the power plug has been disconnected and connect the computer to the drive unit.
3. Connect the power plug of the personal computer to the AC power socket.

- When using a personal computer with battery

The computer can be used as it is.

■Connection with other devices using drive unit communication function

When the drive unit is charged with electricity due to connection with a personal computer and the charged drive unit is connected with other devices, the drive unit or the connected devices may malfunction. Connect the drive unit and other devices with the following procedure.

1. Shut off the power of the device to be connected with the drive unit.
2. Shut off the power of the drive unit that was connected with the personal computer, and check that the charge light is off.
3. Connect the device with the drive unit.
4. Turn on the power of the drive unit and the connected device.

6.3 Selection example of wires

Point

To comply with the IEC/EN/UL/CSA standard for wiring, use the wires described in the MR-J5D Safety Instructions and Precautions for AC Servos (IB(NA)-0300527). To comply with other standards, use wires that comply with each standard.

Selection requirements for the wire size are as follows.

Construction requirements: Single wire set in midair

Wiring length: 30 m or less

The following shows the wires used for wiring. Use the wires given in this section or equivalent wires.

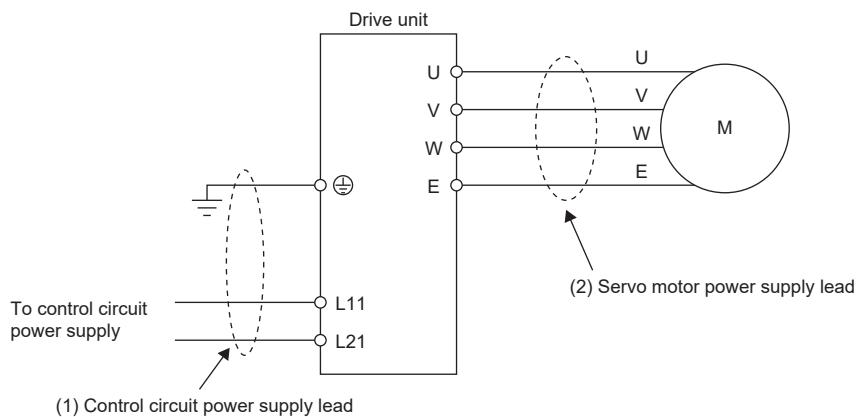

Wire size selection examples

Selection examples for the 600 V Grade heat-resistant polyvinyl chloride insulated wire (HIV wire) are indicated below. Refer to the following for selection examples for crossover wiring of the control circuit power supply.

 Page 123 For crossover wiring of the control circuit power supply

■400 V class

Drive unit ^{*2}	Wire [mm ²] ^{*1*3}	
	(1) L11/L21/ 	U/V/W/E
MR-J5D1-100G4	1.25 to 2 (AWG 16 to 14): a ^{*4}	1.25 to 2 (AWG 16 to 14)
MR-J5D1-200G4		
MR-J5D1-350G4		
MR-J5D1-500G4		3.5 (AWG 12)
MR-J5D1-700G4		5.5 (AWG 10)
MR-J5D2-100G4		1.25 to 2 (AWG 16 to 14)
MR-J5D2-200G4		
MR-J5D2-350G4		
MR-J5D2-500G4		3.5 (AWG 12)
MR-J5D2-700G4		5.5 (AWG 10)
MR-J5D3-100G4		1.25 to 2 (AWG 16 to 14)
MR-J5D3-200G4		

*1 The alphabetical letters in the table indicate the symbols of the selection example of crimp terminals.

 Page 122 Selection example of crimp terminals

*2 For connection to the terminal block, use the screws included with the terminal block.

*3 The wires are selected based on the largest rated current among the servo motors to be combined.

*4 The minimum wire size required by the National Electrical Code is AWG 14 (2 mm²).

Selection example of crimp terminals

Symbol	Drive unit side crimp terminal		Manufacturer
	Crimp terminal	Applicable tool	
a	FVD2-4	YNT-1614	JST (J.S.T. Mfg. Co., Ltd.)

6.4 Molded-case circuit breakers, fuses

When using a fuse instead of the molded-case circuit breaker, use the one having the specifications given in this section.

Precautions

- Select the molded-case circuit breakers specified in this section.
- Wire the molded-case circuit breaker and magnetic contactor as recommended.
- For the molded-case circuit breaker/fuse for the main circuit power supply, refer to "Molded-case circuit breakers, fuses, magnetic contactors" in the following manual.

📖 MR-CV Power Regeneration Converter Unit User's Manual

Selection example (for control circuit power supply)

Install an overcurrent protection device (molded-case circuit breaker, fuse, etc.) to protect the branch circuit.

For crossover wiring of the control circuit power supply

Wire L11 and L21 as follows.

Refer to the following items for wires.

📖 Page 124 Molded-case circuit breaker

📖 Page 124 Fuse

The figure is drawn with the terminal block cover removed.

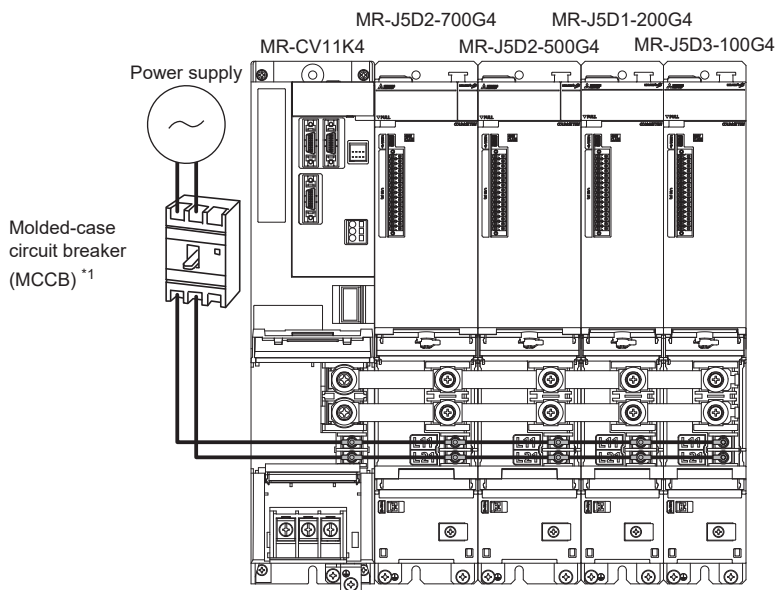

*1 Install a dedicated molded-case circuit breaker for the control circuit power supply. Do not share the molded-case circuit breaker with the main circuit power supply.

■Molded-case circuit breaker

Use a molded-case circuit breaker that has operation characteristics that will not be triggered by inrush current.

—	Number of connected converter units/drive units														Voltage AC [V]
	1	2	3	4	5	6	7	8	9	10	11	12	13	14	
Molded-case circuit breaker	30 A frame 5A		30 A frame 10A		30 A frame 15A			30 A frame 20A		30 A frame 30A				480	
Wire size	2 (AWG 14)					3.5 (AWG 12)			5.5 (AWG 10)				—		
Crimp terminal	a *1					b *1				—					

*1 The alphabetical letters in the table indicate the symbols of the selection example of crimp terminals.

☞ Page 124 Selection example of crimp terminals (crossover wiring)

■Fuse

Use a fuse with a fusing characteristic that will not fuse under repeated inrush currents.

—	Number of connected converter units/drive units														Voltage AC [V]
	1	2	3	4	5	6	7	8	9	10	11	12	13	14	
Fuse [A]	5		10		15			20	25				30		600
Wire size	2 (AWG 14)					3.5 (AWG 12)			5.5 (AWG 10)				—		
Crimp terminal	a *1					b *1				—					

*1 The alphabetical letters in the table indicate the symbols of the selection example of crimp terminals.

☞ Page 124 Selection example of crimp terminals (crossover wiring)

■Selection example of crimp terminals (crossover wiring)

Symbol	Crimp terminal	Applicable tool	Manufacturer
a	FVD2-4	YNT-1614	JST (J.S.T. Mfg. Co., Ltd.)
b	FVD5.5-4	YNT-1210S	

■When the total number of connected units exceeds 14

If the total number of power regeneration converter units and drive units exceeds 14, use two power supplies. The following is an example of wiring the control circuit when 25 drive units are connected.

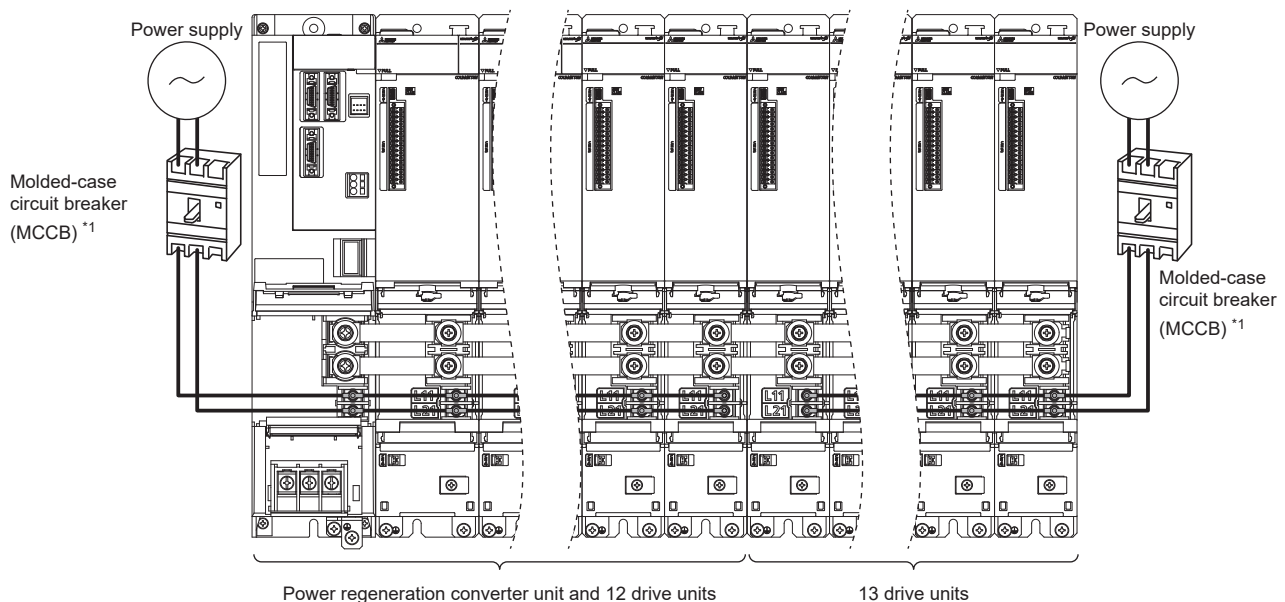

*1 Install a dedicated molded-case circuit breaker for the control circuit power supply. Do not share the molded-case circuit breaker with the main circuit power supply.

For branch wiring of the control circuit power supply

■400 V class

Drive unit	Molded-case circuit breaker *1		Fuse (Class T)		Fuse (Class K5)	
	Frame, rated current	Voltage AC [V]	Current [A]	Voltage AC [V]	Current [A]	Voltage AC [V]
MR-J5D_-_G_	30 A frame 5 A	480	1	600	1	600

*1 To comply with the IEC/EN/UL/CSA standards, refer to the MR-J5D Safety Instructions and Precautions for AC Servos (IB(NA)-0300527) for selection of molded-case circuit breakers and fuses.

Selection examples that comply with IEC/EN/UL 61800-5-1 and CSA C22.2 No.274

The semiconductor fuses and recommended wire gauges in the tables are selections based on the rated I/O of the converter unit/drive unit.

Semiconductor fuse

■400 V class

Power regeneration converter unit	Semiconductor fuse (700 V) SCCR 100 kA (Manufactured by Eaton Bussman)
MR-CV11K4	170M1413 (40 A)
MR-CV18K4	170M1416 (80 A)
MR-CV30K4	170M1419 (160 A)
MR-CV37K4	170M1419 (160 A)
MR-CV45K4	170M1420 (200 A)
MR-CV55K4	170M1421 (250 A)
MR-CV75K4	170M1422 (315 A)

Recommended wire

■400 V class

Drive unit	75 °C Stranded wire [AWG]	
	L11/L21/⊕	U/V/W/E
MR-J5D1-100G4	14	14
MR-J5D1-200G4		
MR-J5D1-350G4		
MR-J5D1-500G4		12
MR-J5D1-700G4		10
MR-J5D2-100G4		14
MR-J5D2-200G4		
MR-J5D2-350G4		
MR-J5D2-500G4		12
MR-J5D2-700G4		10
MR-J5D3-100G4		14
MR-J5D3-200G4		

6.5 Relay (recommended)

The following relays should be used with each interface.

Interface	Selection example
Digital input signal (interface DI-1) Relay used for digital input command signals	To prevent loose connections, use a relay for small signal (twin contacts). (Ex.) Omron: type G2A, type MY
Digital output signal (interface DO-1) Relay used for digital output signals	Small relay with 12 V DC or 24 V DC of rated current 40 mA or less (Ex.) Omron: type MY

6.6 Noise reduction techniques

Noises are classified into external noises, which enter the converter unit/drive unit to cause it to malfunction, and those radiated by the converter unit/drive unit to cause peripheral equipment to malfunction. Because the converter unit/drive unit is an electronic device that handles small signals, the following general noise reduction techniques are required.

The drive unit can also be a source of noise as its outputs are chopped by high carrier frequencies. If peripheral equipment malfunctions due to noise produced by the drive unit, take measures to reduce the noise. The reduction techniques will vary slightly with the routes of noise transmission.

Noise reduction techniques

General reduction techniques

- Avoid bundling power lines (input/output lines) and signal cables together or running them in parallel to each other. Separate the power lines from the signal cables.
- Use a shielded twisted pair cable for connection with the encoder and for control signal transmission, and connect the external conductor of the cable to the SD terminal.
- For grounding, refer to the following.

 Page 83 Grounding

Reduction techniques for external noises that cause the converter unit/drive unit to malfunction

If there are noise sources (such as a magnetic contactor, an electromagnetic brake, and many relays) that make a large amount of noise near the converter unit/drive unit and the converter unit/drive unit may malfunction, the following countermeasures are required.

- Provide surge killers on the noise sources to suppress noise.
- Attach data line filters to the signal cables.
- Ground the shields of the encoder connecting cable and the control signal cables with cable clamp fittings.
- Although a surge absorber is built into the converter unit, to protect the converter unit/drive unit and other equipment against large exogenous noise and lightning surge, attaching a varistor to the power input section of the equipment is recommended.

Techniques for noises radiated by the converter unit/drive unit that cause peripheral equipment to malfunction

Noises produced by the converter unit/drive unit are classified into those radiated from the cables connected to the converter unit/drive unit and its main circuits (input/output), those induced electromagnetically or statically by the signal cables of the peripheral equipment located near the main circuit cables, and those transmitted through the power supply cables.

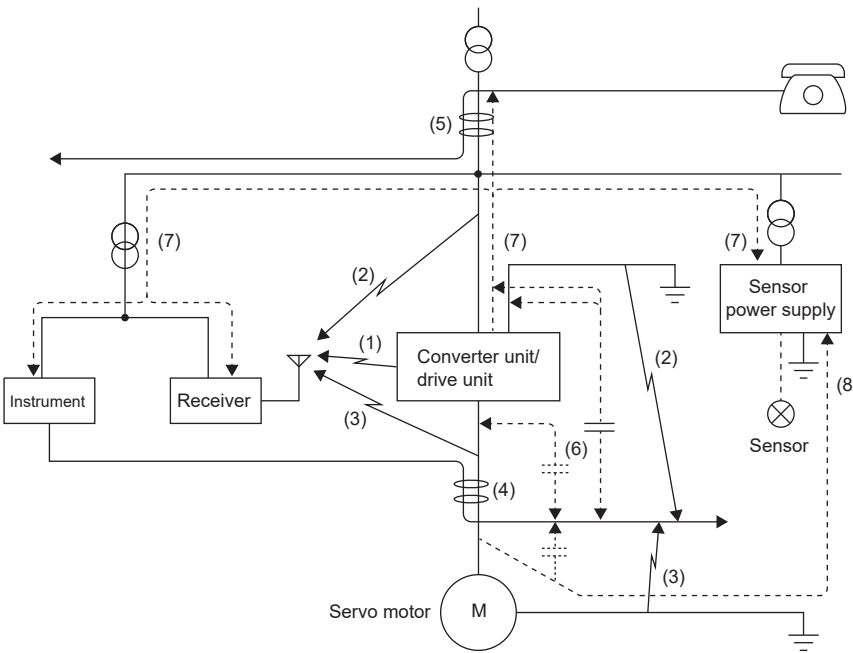
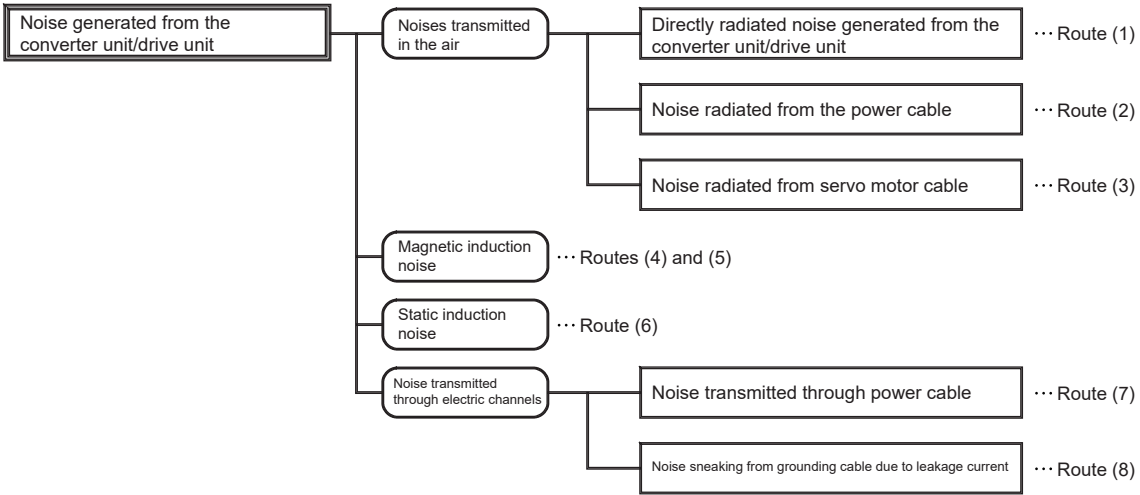

Noise transmission route	Suppression techniques
(1), (2), (3)	<p>A malfunction due to noise transmitted through the air may occur in devices which handle weak signals and are susceptible to noise, such as measuring instruments, receivers and sensors. In addition, a malfunction may also occur when their signal cables are stored in a cabinet together with the converter unit/drive unit or when the signal cables run near the converter unit/drive unit. Take the following measures to prevent a malfunction:</p> <ul style="list-style-type: none"> • Provide maximum clearance between easily affected devices and the converter unit/drive unit. • Provide maximum clearance between easily affected signal cables and the I/O cables of the converter unit/drive unit. • Avoid bundling power lines (input/output lines of the converter unit/drive unit) and signal cables together or running them in parallel to each other. • Insert a line noise filter to the I/O cables or a radio noise filter on the input line to reduce radiated noise from the cables. • Use shielded wires for the signal and power lines, or put the lines in separate metal conduits.
(4), (5), (6)	<p>When power cables and signal cables are laid side by side or bundled together, electromagnetic and static induction noise is transmitted to the signal cables, causing malfunctions. Take the following precautions to protect the signal cables against noise.</p> <ul style="list-style-type: none"> • Provide maximum clearance between easily affected devices and the converter unit/drive unit. • Provide maximum clearance between easily affected signal cables and the I/O cables of the converter unit/drive unit. • Avoid bundling power lines (input/output lines of the converter unit/drive unit) and signal cables together or running them in parallel to each other. • Use shielded wires for the signal and power lines, or put the lines in separate metal conduits.
(7)	<p>When the power supply of peripheral equipment is connected to the power supply of the converter unit/drive unit system, noise produced by the converter unit/drive unit may be transmitted back through the power supply cable, and the equipment may malfunction. The following techniques are required.</p> <ul style="list-style-type: none"> • Install the radio noise filter (FR-BIF(-H)) on the power lines (input lines) of the converter unit/drive unit. • Install the line noise filter (FR-BLF) on the power lines of the converter unit/drive unit.
(8)	<p>If the grounding wires of the peripheral equipment and the converter unit/drive unit make a closed loop circuit, leakage current may flow through, causing the equipment to malfunction. In this case, the malfunction may be prevented by disconnecting the grounding wires from the equipment.</p>

Noise reduction techniques for the network cable

Point

Take measures against noise for both ends of the network cable.

If using the network cable in an environment with excessive noise, directly connect the shield of the cable to the ground plate with cable clamp fittings at a place 200 mm to 300 mm or less from the drive unit.

When connecting the network cable from outside the cabinet, connect it to the ground plate 5 mm to 10 mm away from the cabinet entrance.

To reinforce noise reduction techniques, installing a data line filter (TDK ZCAT1730-0730) to the network cable is recommended. Install the data line filter to a place 80 mm or less from the drive unit.

■ Inside the cabinet

- When using cable clamp fittings

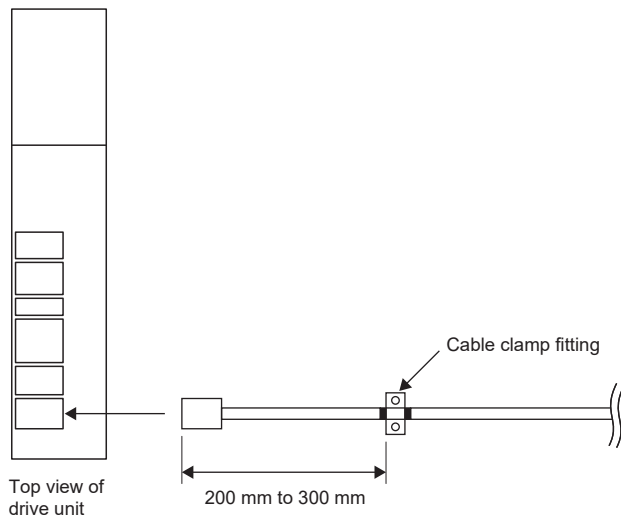

- When using a data line filter

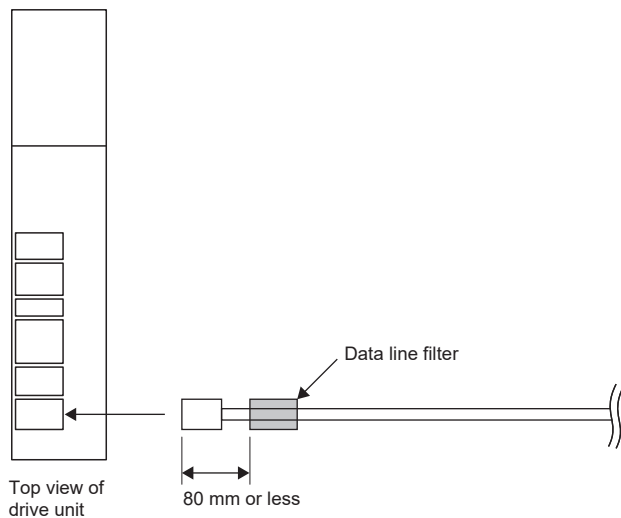

■ Outside the cabinet

- When using cable clamp fittings

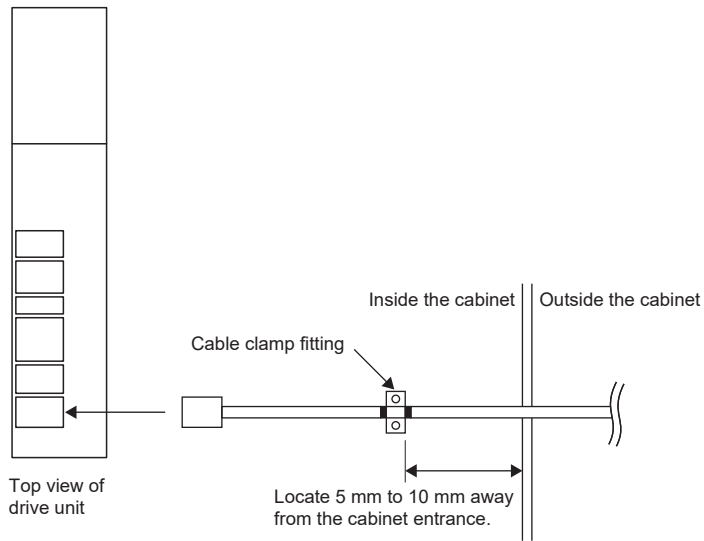

- When using a data line filter

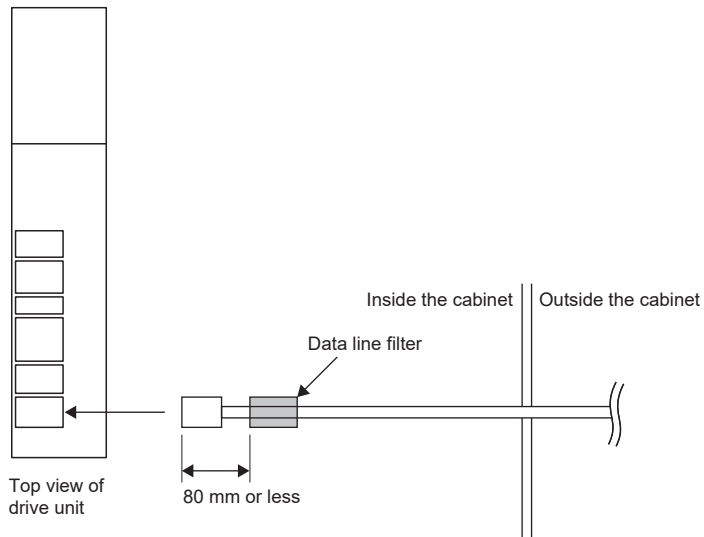

Noise reduction products

For the noise reduction products to be connected to the converter unit, refer to "Noise reduction products" in the following manual.

📖MR-CV Power Regeneration Converter Unit User's Manual

Data line filter (recommended)

Noise can be prevented by installing a data line filter onto cables such as the encoder cable.

For example, ZCAT3035-1330 by TDK, ESD-SR-250 by TOKIN, GRFC-13 by Kitagawa Industries, and E04SRM563218 by SEIWA ELECTRIC are available as data line filters.

As a reference example, the impedance specifications of the ZCAT3035-1330 (TDK) are indicated below. These impedances are reference values and not guaranteed values.

Impedance [Ω]	
10 MHz to 100 MHz	100 MHz to 500 MHz
80	150

[Unit: mm]

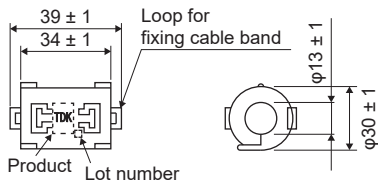

Dimensions (ZCAT3035-1330)

Surge killer (recommended)

Use of a surge killer is recommended for AC relay, magnetic contactor or the like near the drive unit. Use the following surge killer or equivalent.

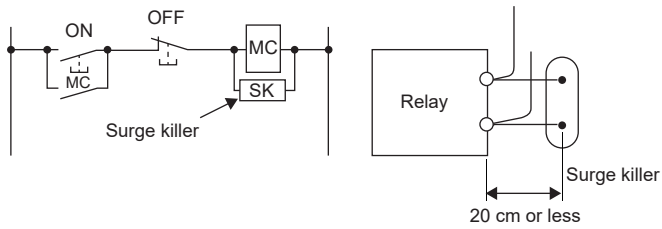

Ex.

CR-50500 (Okaya Electric Industries)

Rated voltage AC [V]	C [μF $\pm 20\%$]	R [Ω $\pm 30\%$]	Test voltage	Dimensions [Unit: mm]
250	0.5	50 (1/2W)	Between terminals: 625 V AC, 50 Hz/60 Hz 60 s Between terminal and case: 2000 V AC 50/60 Hz 60 s	

Note that a diode should be installed to a DC relay or the like.

Maximum voltage: Not less than four times the drive voltage of the relay or the like

Maximum current: Not less than two times the drive current of the relay or the like

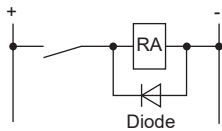

Cable clamp fitting

Generally, connecting the grounding wire of the shielded wire to the SD terminal of the connector provides a sufficient effect. However, the effect can be increased when the shielded wire is connected directly to the ground plate as shown below. Install the ground plate near the drive unit for the encoder cable. Peel part of the cable insulator to expose the external conductor, and press that part against the ground plate with the cable clamp. If the cable are thin, bunch several cables together and clamp them in place.

Precautions

- The motor cable (single cable type) has no shield on the outermost circumference. Therefore, to ground the motor cable with a cable clamp, use a motor cable (dual cable type).

■AERSBAN-_SET

The cable clamp comes as a set with the grounding plate.

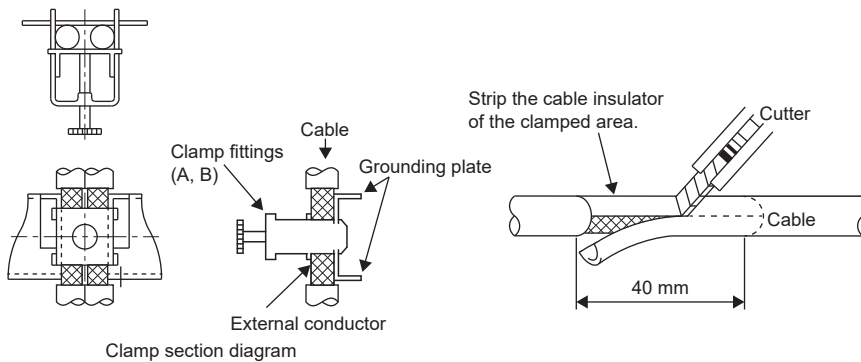

• Dimensions

[Unit: mm]

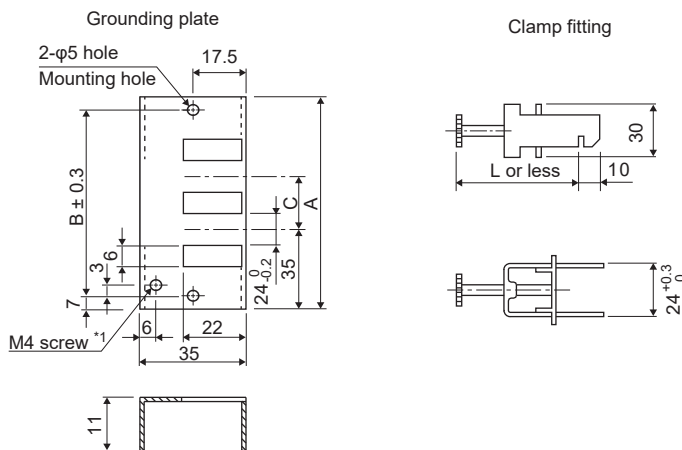

*1 Screw hole for grounding. Connect it to the ground plate of the cabinet.

Model	A	B	C	Accessory fittings
AERSBAN-DSET	100	86	30	Clamp A: 2 pcs.
AERSBAN-ESET	70	56	—	Clamp B: 1 pc.
Clamp fitting		L		
A		70		
B		45		

6.7 Earth-leakage current breaker

For details on how to select an earth-leakage circuit breaker, refer to "Earth-leakage current breaker" in the following manual.

📖 MR-CV Power Regeneration Converter Unit User's Manual

Servo motor leakage current example (Igm)

Servo motor output [kW]	Leakage current [mA]
0.05 to 1	0.1
1.2 to 2	0.2
3 to 3.5	0.3
4.2 to 5	0.5
6 to 7	0.7

Drive unit leakage current example (Iga)

Drive unit	Leakage current [mA]
MR-J5D1-100_ MR-J5D1-200_ MR-J5D1-350_	0.3
MR-J5D1-500_ MR-J5D1-700_	0.5
MR-J5D2-100_ MR-J5D2-200_ MR-J5D2-350_	0.3
MR-J5D2-500_ MR-J5D2-700_	0.5
MR-J5D3-100_ MR-J5D3-200_	0.3

7 ABSOLUTE POSITION DETECTION SYSTEM

Precautions

- If [AL. 025 Absolute position erased] or [AL. 0E3 Absolute position counter warning] occurs, execute homing again.

7.1 Outline

Characteristics

The encoder consists of a circuit designed to detect a position within one revolution and the number of revolutions.

The absolute position detection system always detects and memorize the absolute position of the machine, regardless of whether the controller power is on/off. Therefore, once homing is performed at the time of machine installation, homing is not needed when power is switched on thereafter.

Even if a power failure or a malfunction occurs, the system can be easily restored.

Restrictions [G]

The absolute position detection system cannot be configured in the following conditions.

- When an incremental type encoder is being used
- Stroke-less coordinate system for infinite positioning and the like in combination with a controller other than a Mitsubishi Electric motion module

Precautions

Even when using a servo motor with battery-less absolute position encoder, absolute position data is erased under the following conditions. If the absolute position data is erased, perform homing again.

- The servo motor or drive unit is replaced.
- The incremental system is enabled.
- [Pr. PA01 Operation mode selection] is changed.

When a servo motor other than the one that was connected at the startup of the absolute position detection system is connected, [AL. 01A Servo motor combination error] occurs. In such cases, reconnect the servo motor that was connected at the startup of the absolute position detection system to operate without losing the absolute position data. When replacing a servo motor, refer to the following.

 Page 137 Procedure of replacing a servo motor with battery-less absolute position encoder

System architecture

The following shows the architecture of the absolute position detection system.

When connecting the battery-less absolute position encoder

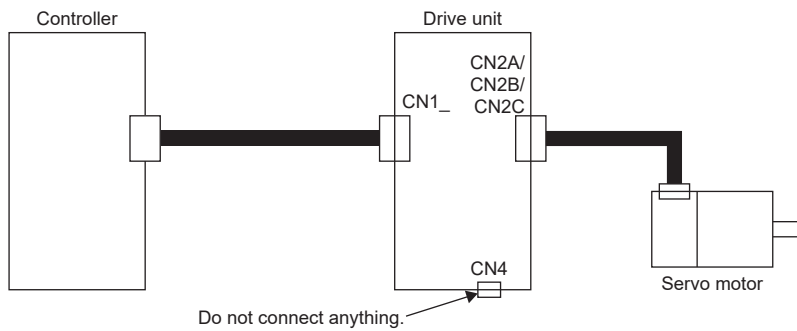

Servo parameter setting [G]

Set [Pr. PA03 Absolute position detection system] to "1" (enabled (absolute position detection system)).

Homing

After the absolute position detection system is enabled, [AL. 025 Absolute position erased] occurs at the initial startup. Then, ABSV (Absolute position erased) turns on. Refer to "CONTROL MODE" in the following manual and perform homing.

📖MR-J5 User's Manual (Function)

Checking the detected absolute position data

Absolute position data can be checked with MR Configurator2.

Choose "Monitor" and "ABS Data Display" to open the absolute position data display screen.

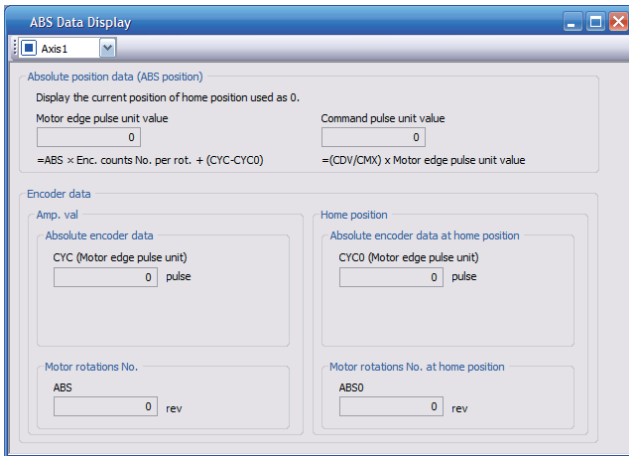

No.	Item		Screen operation
	MR Configurator2	System architecture *1	
(1)	Motor (machine) side pulse unit value	—	Acquires and displays values in the unit of the servo motor (machine) side pulses from the drive unit of the specified axis.
(2)	Command pulse unit value	Current position	Acquires and displays the command pulse unit value from the drive unit for the specified axis.
(3)	CYC	1X	[G]: Acquires and displays the position within one revolution in the unit of the servo motor (machine) side pulses from the drive unit of the specified axis.
(4)	ABS	LS	Acquires and displays the multi-revolution counter travel distance from the absolute home position from the drive unit of the specified axis.
(5)	CYC0	1XO	[G]: Acquires and displays the home position within one revolution in the unit of the servo motor (machine) side pulses from the drive unit of the specified axis.
(6)	ABS0	LSO	Acquires and displays the multi-revolution counter value of the absolute home position from the drive unit of the specified axis.

*1 For the structural drawing, refer to the following.
 Page 138 Connecting the battery-less encoder

Procedure of replacing a servo motor with battery-less absolute position encoder

To replace a servo motor with battery-less absolute position encoder, use the following procedure.

1. Replacing the servo motor

Turn off the power and replace the servo motor.

2. Canceling [AL. 01A Servo motor combination error]

After the power is turned on, [AL. 01A.5 Servo motor combination error 3] occurs.

After setting [Pr. PA03.1 Servo motor replacement preparation] to "1" (enabled), cycle the power and then deactivate [AL. 01A.5].

3. Homing

The absolute position data is erased by servo motor replacement. Perform homing again before operation.

7.2 Configuration and specifications

Connecting the battery-less encoder

The following shows an example of battery-less encoder connection.

System architecture

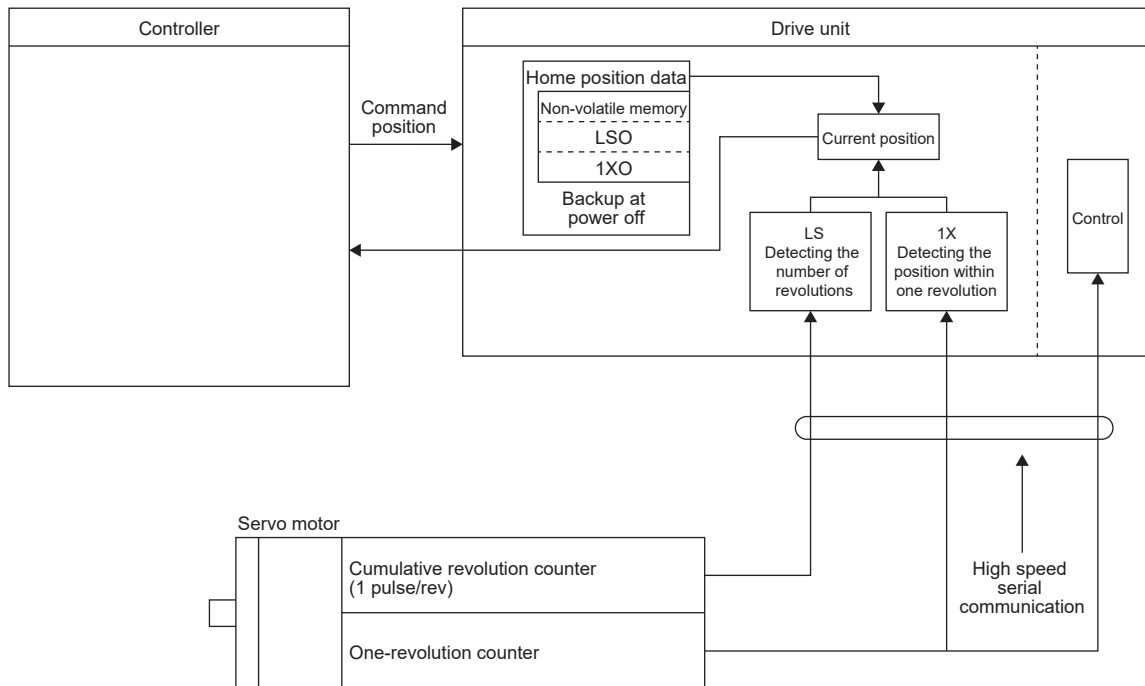

Specification list

Item	Description	
System	Electronic, battery backup type	
Maximum revolution range	Home position \pm 32767 rev	
Maximum speed at power failure [r/min] *1	Rotary servo motor manufactured by Mitsubishi Electric	8000 (only when the acceleration/deceleration time until 8000 r/min is 0.2 s or longer)

*1 Maximum speed available when the shaft is rotated by external force at the time of power failure. Also, if power is switched on when the servo motor is rotated by an external force at a speed of 3000 r/min or higher, position mismatch may occur.

8 USING STO FUNCTION

Precautions

- In the torque mode, the forced stop deceleration function cannot be used.

8.1 Introduction

This section provides the cautions of the STO function.

To extend functional safety by setting [Pr. PSA01.0] to "1", refer to the following.

☞ Page 150 USING FUNCTIONAL SAFETY

Precautions

- Do not improperly install safety-related components or systems. Installation should be performed by qualified personnel.

Outline

This drive unit complies with the following safety standards.

Item	MR-J5D_
Safety sub-function	STO (IEC/EN 61800-5-2)
Satisfied standards	EN ISO 13849-1:2015 Category 4 PL e, IEC 61508 SIL 3, EN 62061 SIL CL 3, EN 61800-5-2

Terms related to safety

The STO function shuts off energy to servo motors, thus removing torque. MR-J5D_ shuts off the energy by turning off the power supply electronically in the drive unit.

The purpose of this function is as follows.

- Uncontrolled stop according to stop category 0 of IEC/EN 60204-1
- Preventing unexpected restart

Precautions

The following basic safety instructions must be read carefully and fully to prevent injury to persons or damage to property. Only qualified personnel are authorized to install, startup, repair, or adjust the machines in which these components are installed.

They must be familiar with all applicable local regulations and laws in which machines with these components are installed, particularly the standards mentioned in this user's manual.

The staff responsible for this work must be given express permission from the company to perform startup, programming, configuration, and maintenance of the machine in accordance with the safety standards.

This drive unit satisfies the Safe Torque Off (STO) function described in IEC/EN 61800-5-2 by preventing the energy supply from the drive unit to the servo motor. If an external force acts upon the drive axis, additional safety measures, such as brakes or counterbalances must be used.

Residual risks of the STO function

Machine manufacturers are responsible for all risk evaluations and all associated residual risks. Below are residual risks associated with the STO function. Mitsubishi Electric is not liable for any damages or injuries caused by these risks.

- The STO function disables energy supply to the servo motor by electrical shut-off. The function does not mechanically disconnect electricity from and servo motor. Therefore, this function cannot prevent exposure to electric shock. To prevent an electric shock, install a magnetic contactor or a molded-case circuit breaker to the main circuit power supply (L1/L2/L3) of the converter unit.
- The STO function disables energy supply to the servo motor by electrical shut-off. It does not guarantee stop control or deceleration control of the servo motor.
- For proper installation, wiring, and adjustment, thoroughly read the installation guide of each individual safety related component.
- In the safety circuit, use components that are confirmed safe or meet the required safety standards.
- The STO function does not guarantee that the drive part of the servo motor will not rotate due to external or other forces.
- Safety is not assured until safety-related components of the system are completely installed or adjusted.
- When replacing this drive unit, confirm that the new drive unit is exactly the same model as that being replaced. After the replacement, check the performance of the functions before using the system.
- Perform all risk assessments to the machine or the entire system.
- To prevent accumulation of malfunctions, perform function checks at regular intervals based on the risk assessments of the machine or the system. Regardless of the system safety level, malfunction checks should be performed at least once per year.
- If the upper and lower power modules in the drive unit are shorted and damaged simultaneously, the servo motor may make a half revolution at a maximum.

Specifications

Drive unit specifications

For information on drive unit specifications, refer to "Functional safety" in the User's Manual (Introduction).

Function block diagram (STO function)

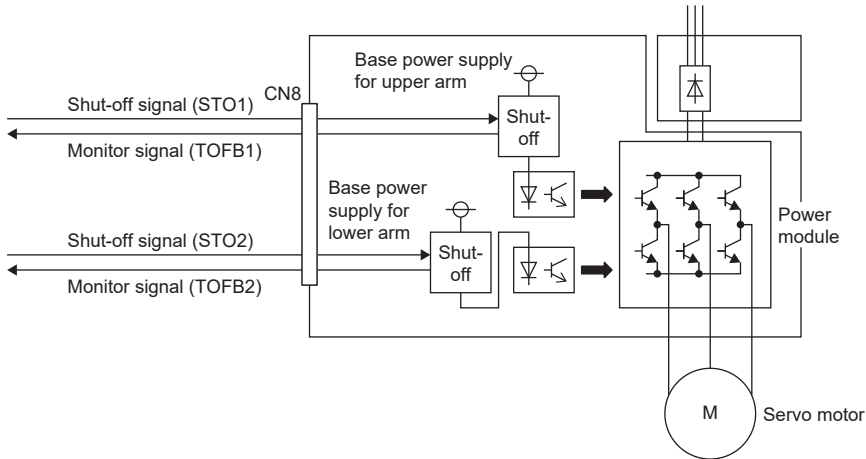

Operation sequence (STO function)

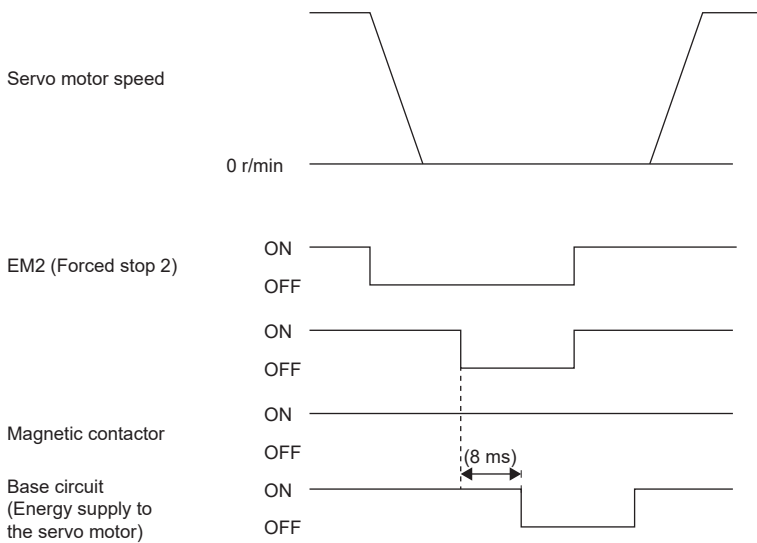

Maintenance

This drive unit has alarms and warnings for maintenance compatible with the Mitsubishi Electric Drive Safety function.

MR-J5 User's Manual (Troubleshooting)

8.2 Functional safety I/O signal connector (CN8) and pin assignments

Pin assignment



The pin assignments of the connectors are as viewed from the cable connector wiring section.

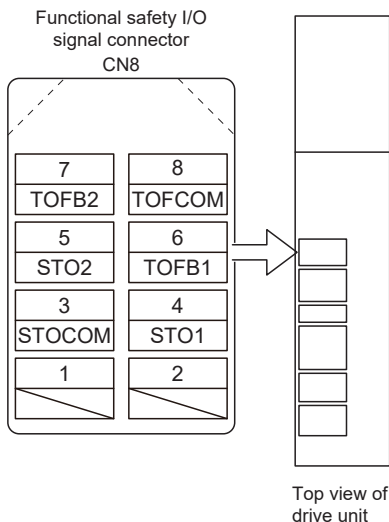

Signal (device) explanation

I/O device

Signal name	Connector pin No.	Description	I/O signal interface type
STOCOM	CN8-3	Common terminal for the STO1 and STO2 input signals	DI-1
STO1	CN8-4	Input the STO status of STO1. STO state (base circuit shut-off): Open between STO1 and STOCOM. STO release state (in driving): Close between STO1 and STOCOM. Before turning off STO1, stop the servo motor in the servo-off state or with forced stop deceleration by turning off EM2 (Forced stop 2).	DI-1
STO2	CN8-5	Input the STO status of STO2. STO state (base circuit shut-off): Open between STO2 and STOCOM. STO release state (in driving): Close between STO2 and STOCOM. Before turning off STO2, stop the servo motor in the servo-off state or with forced stop deceleration by turning off EM2 (Forced stop 2).	DI-1
TOFCOM	CN8-8	Common terminal for the TOFB1 and TOFB2 output signals	DO-1
TOFB1	CN8-6	Outputs the STO status of STO1. STO state (base circuit shut-off): Closed between TOFB1 and TOFCOM. STO release state (in driving): Open between TOFB1 and TOFCOM.	DO-1
TOFB2	CN8-7	Outputs the STO status of STO2. STO state (base circuit shut-off): Closed between TOFB2 and TOFCOM. STO release state (in driving): Open between TOFB2 and TOFCOM.	DO-1

Signals and STO status

The following table shows the status of TOFB and STO for when STO1 and STO2 are ON (closed) or OFF (open) while the power is turned on in an operation with no alarms or warnings.

Input signal		Status			
STO1	STO2	Between TOFB1 and TOFCOM (STO1 state)	Between TOFB2 and TOFCOM (STO2 state)	Between TOFB1 and TOFB2 (STO state)	STO
OFF	OFF	ON: STO state	ON: STO state	ON	STO state
OFF	ON	ON: STO state	OFF: STO release state	OFF *1	STO state
ON	OFF	OFF: STO release state	ON: STO state	OFF *1	STO state
ON	ON	OFF: STO release state	OFF: STO release state	OFF	STO release state

*1 Between TOFB1 and TOFB2 is off, but the drive unit is in the STO state.

Test pulse of STO input signal

Set the test pulse off time inputted from outside to 1 ms or less.

How to pull out the STO cable

The following shows how to pull out the STO cable from the CN8 connector of the drive unit.

With the clip (1) of the STO cable plug pressed in the direction of the arrow, hold the plug (2) and pull out.

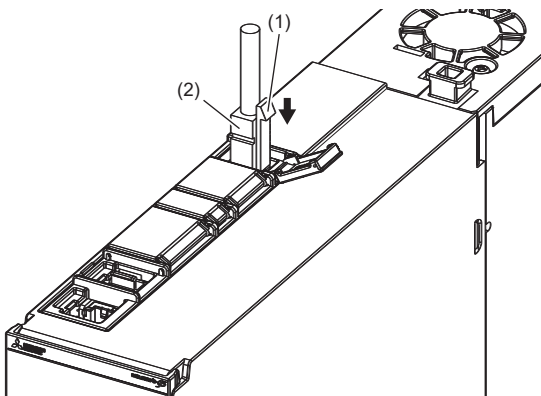

8.3 Connection example

Precautions for compliance with stop category 1 (IEC/EN 60204-1)

Point

- Before turning off STO (STO1 and STO2), stop the servo motor in the servo-off state or by turning off EM2 (Forced stop 2) (delay by SS1). Configure an external sequence that has the timings shown below by using an external device.

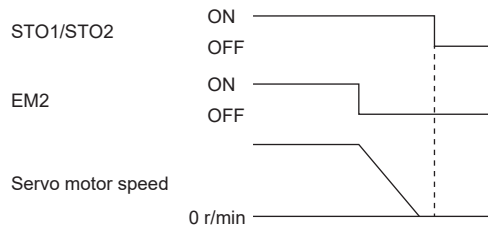

- If STO is turned off during operation, the servo motor stops with the dynamic brake stop (stop category 0).

Precautions for compliance with stop category 0 (IEC/EN 60204-1)

Point

- Before turning off STO (STO1 and STO2), make the servo-off state or turn off EM1 (Forced stop 1). If servo parameter "STO timing error selection" is set to "1 (Not detected)", wiring to EM1 can be omitted. Configure an external sequence that has the timings shown below by using an external device.

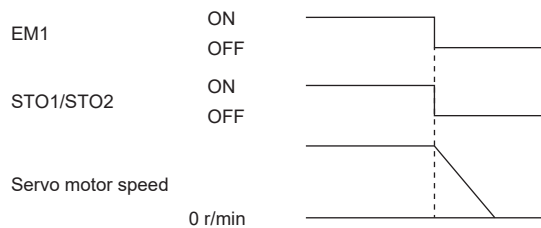

Connection example for CN8 connector

This drive unit is equipped with the connector (CN8) which enables the STO function. When this connector is used with a certified external safety relay, power to the motor can be safely removed and unexpected restart can be prevented. The safety relay used should meet the applicable safety standards and have forcibly guided contacts or mirror contacts for the purpose of error detection.

The following diagram is for source interfaces. For sink interfaces, refer to the following.

☞ Page 147 Sink I/O interface

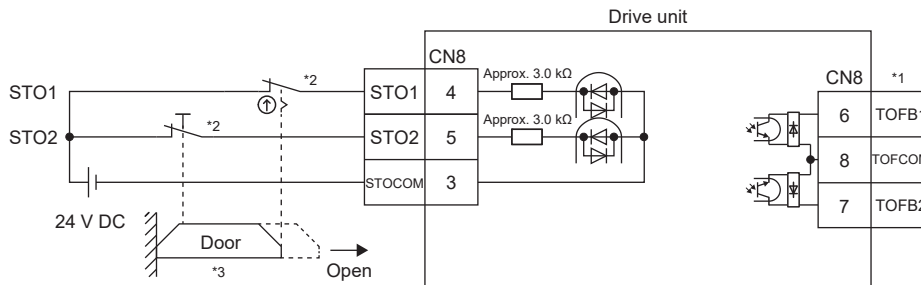

*1 With TOFB, whether the servo is in the STO state can be confirmed. Refer to the following for a connection example.

☞ Page 146 External I/O signal connection example using an external safety relay unit

The safety level depends on the setting value of [Pr. PF18 STO diagnosis error detection time] and whether STO input diagnosis by TOFB output is performed or not. For details, refer to [Pr. PF18] in the following manual.

📖 MR-J5-G/MR-J5W-G User's Manual (Parameters)

*2 When using the STO function, turn off STO1 and STO2 at the same time. Also, before turning off STO1 and STO2, stop the servo motor in the servo-off state or with forced stop deceleration by turning off EM2 (Forced stop 2).

*3 Configure the interlock circuit so that the door opens after the servo motor stops.

External I/O signal connection example using an external safety relay unit



This connection is for source interfaces. For the other I/O signals, refer to the following connection examples.
 Page 48 Example I/O signal connections

This connection example complies with the requirements up to ISO/EN ISO 13849-1:2015 category 3 PL e and IEC/EN 62061 SIL CL 3.

For details, refer to the safety relay module user's manual.

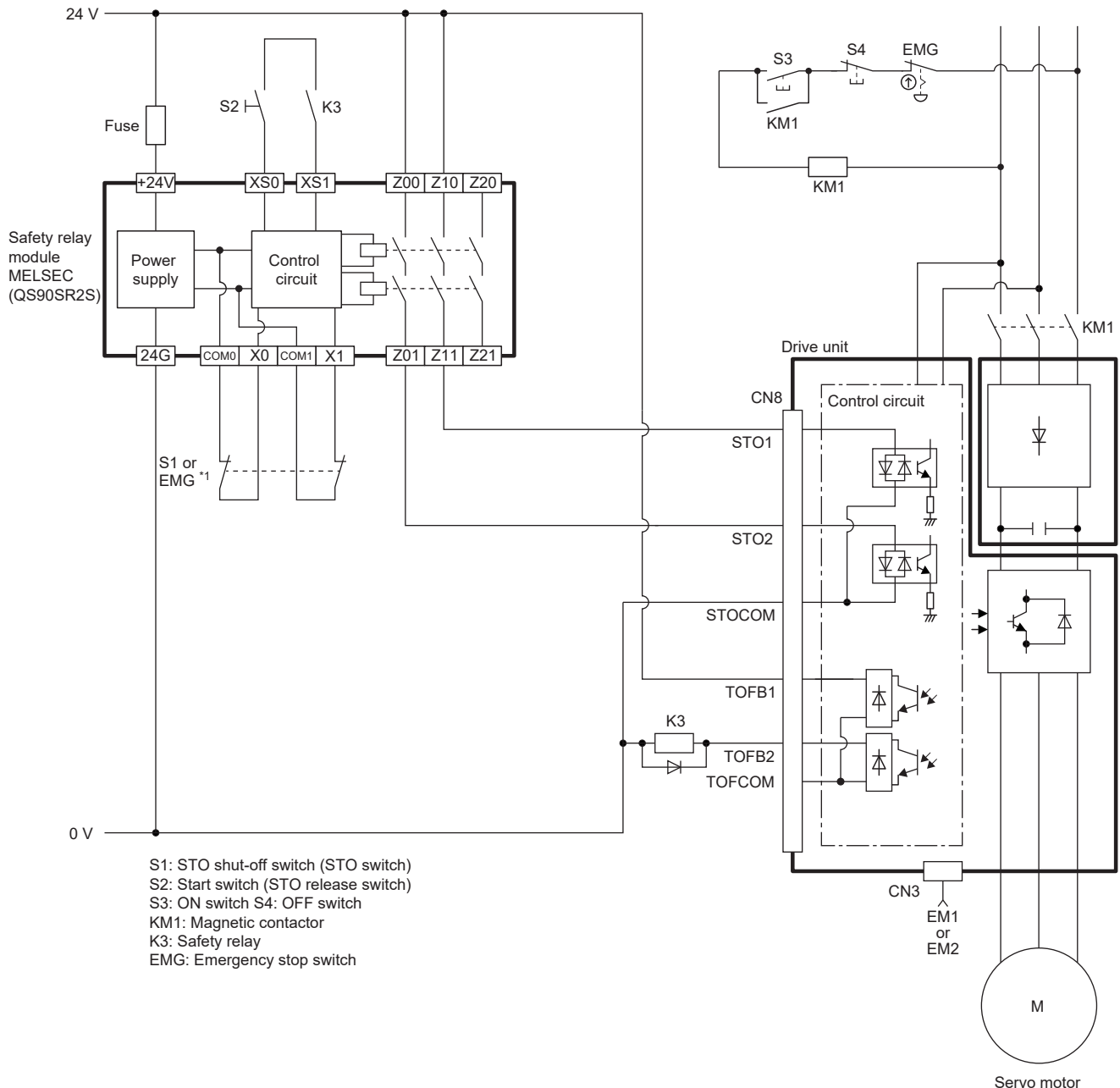

*1 To enable "Emergency switching off" for the shut-off by the STO function of the drive unit, change S1 to EMG. The stop category at this time is "0".

Page 144 Precautions for compliance with stop category 1 (IEC/EN 60204-1)

8.4 Detailed explanation of interfaces

The details of I/O signal interfaces stated in the following section (refer to the I/O signal interface type in the table) are as follows. Refer to the section and connect them with external devices.

☞ Page 142 Functional safety I/O signal connector (CN8) and pin assignments

Sink I/O interface

Digital input interface DI-1

This is an input circuit in which the photocoupler cathode side is the input terminal. Transmit signals from a sink (open-collector) type transistor output, relay switch, etc.

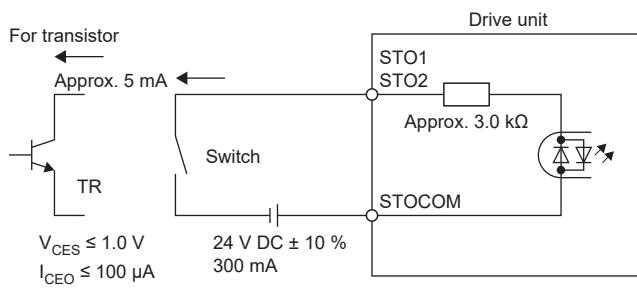

Digital output interface DO-1

This is a circuit in which the collector of the output transistor is the output terminal. When the output transistor is turned on, the current flows to the collector terminal.

A lamp, relay, or photocoupler can be driven. Install a diode (D) for an inductive load, or install an inrush current suppressing resistor (R) for a lamp load.

(Rated current: 40 mA or less, maximum current: 50 mA or less, inrush current: 100 mA or less) A maximum of 5.2 V voltage drop occurs in the drive unit.

■When outputting each of two STO states by using each TOFB

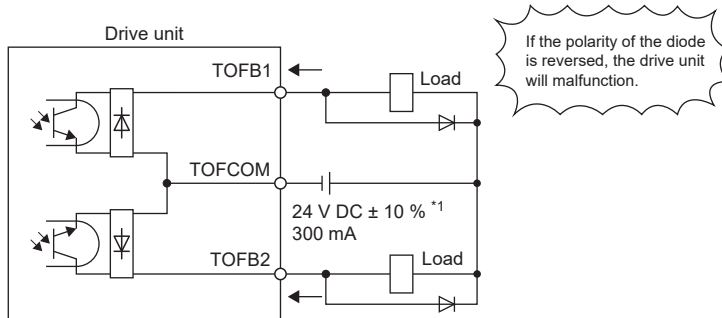

*1 If the voltage drop (a maximum of 2.6 V) interferes with the relay operation, apply high voltage (a maximum of 26.4 V) from an external source.

■When outputting two STO states by using one TOFB

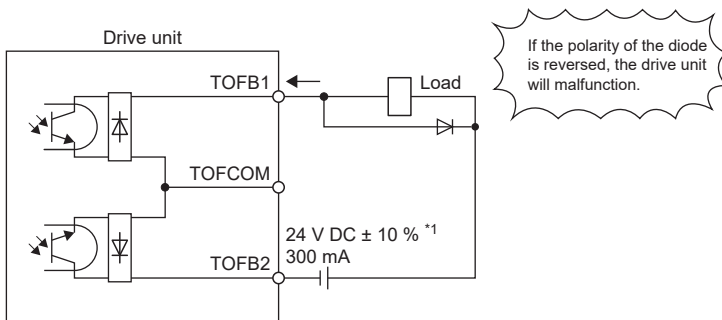

*1 If the voltage drop (a maximum of 5.2 V) interferes with the relay operation, apply high voltage (a maximum of 26.4 V) from an external source.

Source I/O interface

For this drive unit, source type I/O interfaces can be used.

Digital input interface DI-1

This is an input circuit in which the anode of the photocoupler is the input terminal. Transmit signals from a source (open-collector) type transistor output, relay switch, etc.

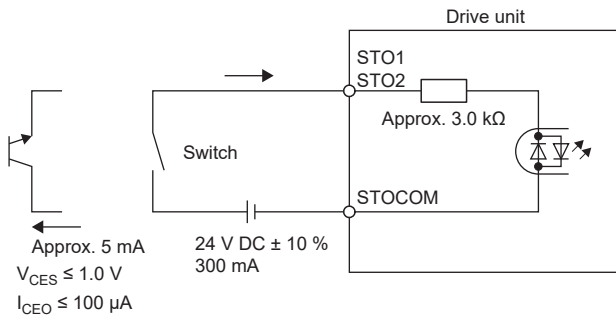

Digital output interface DO-1

This is a circuit in which the emitter of the output transistor is the output terminal. When the output transistor is turned on, the current flows from the output terminal to a load.

A maximum of 5.2 V voltage drop occurs in the drive unit.

When outputting each of two STO states by using each TOFB

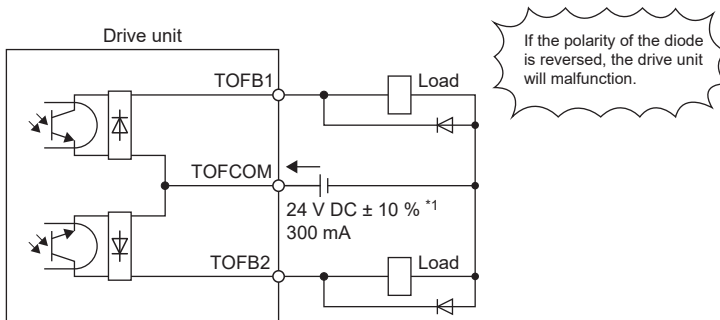

*1 If the voltage drop (a maximum of 2.6 V) interferes with the relay operation, apply high voltage (a maximum of 26.4 V) from an external source.

When outputting two STO states by using one TOFB

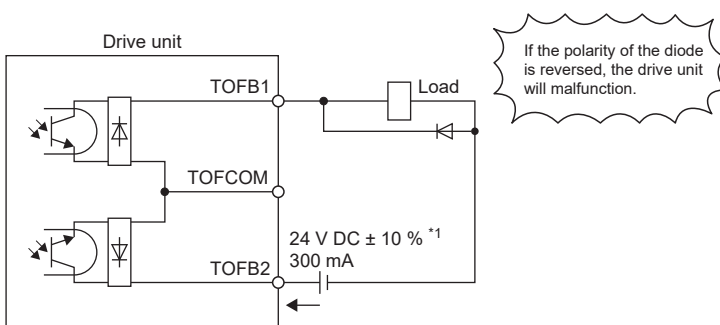

*1 If the voltage drop (a maximum of 5.2 V) interferes with the relay operation, apply high voltage (a maximum of 26.4 V) from an external source.

9 USING FUNCTIONAL SAFETY

9.1 Function block diagram

The following are examples of the MR-J5D1-_G_.

Safety sub-function control by input device

This figure shows a function block configured to allow input devices assigned to the CN8 connector pins to execute safety sub-functions.

The safety level Category 4 PL e, SIL 3 can be achieved with input signal diagnostics.

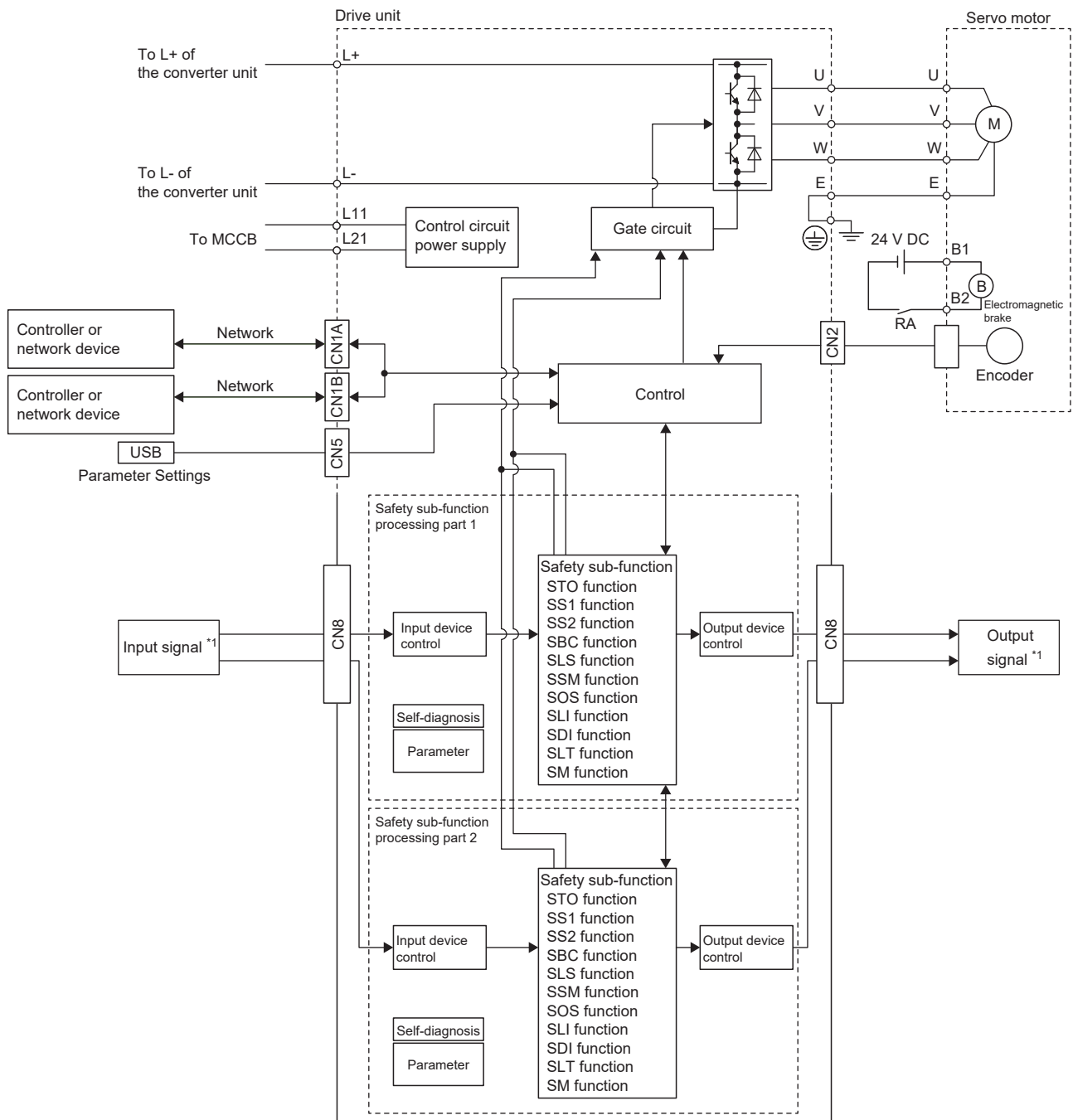

*1 Safety switches, safety relays, etc.

Safety sub-function control by network

This figure shows a function block configured to allow safety sub-functions to be executed via CC-Link IE TSN Network. Wiring can be reduced using this method.

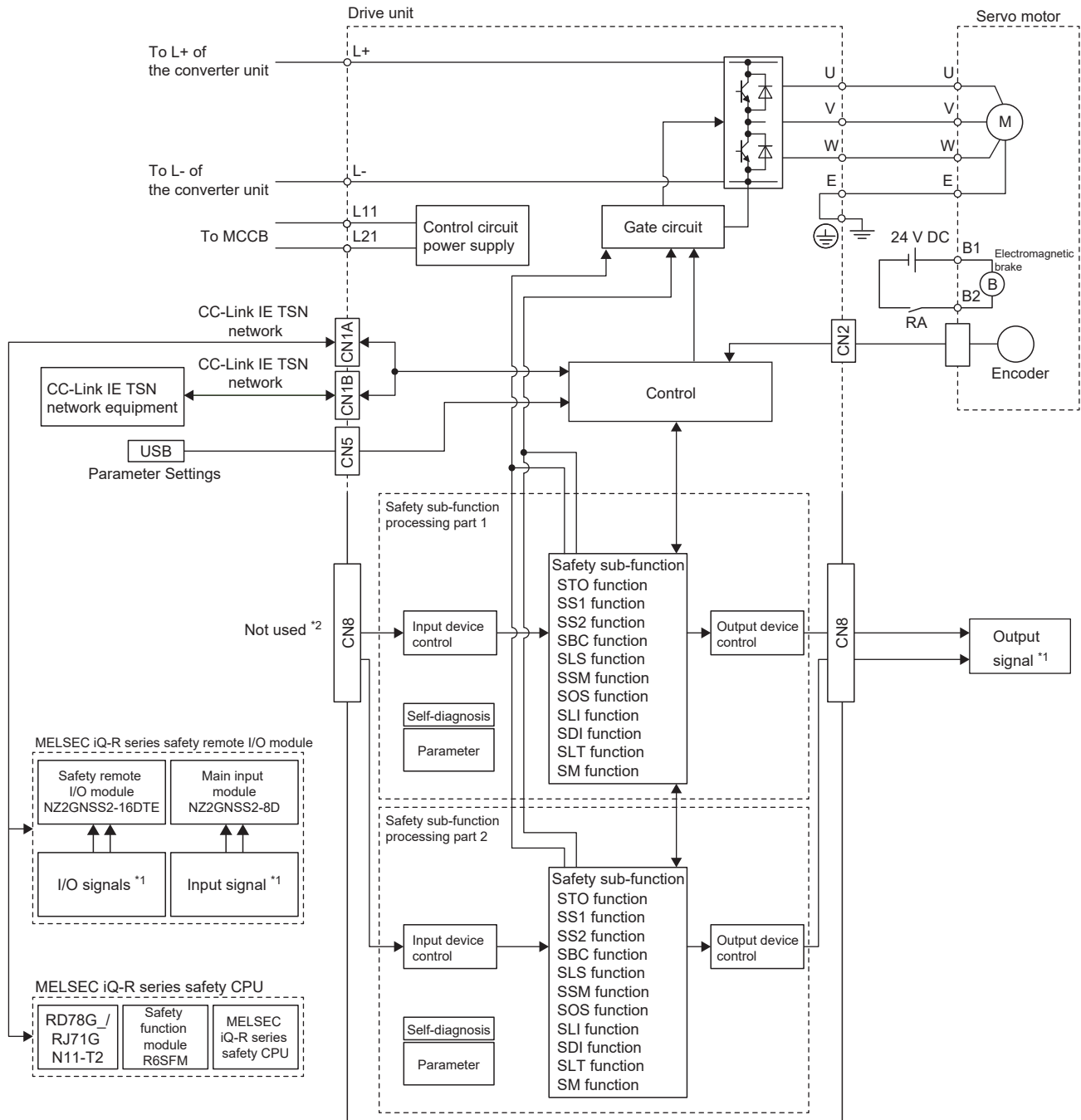

*1 Safety switches, safety relays, etc.

*2 Signal input from CN8 is disabled when using the safety sub-functions over a network. Wire the block so that signals can be input from a controller. The safety sub-functions can still be used even if a short-circuit connector is connected to CN8. CN8 output signals can also be used.

9.2 System architecture

The following are examples of the MR-J5D1-_G_.

Safety sub-function control by input device

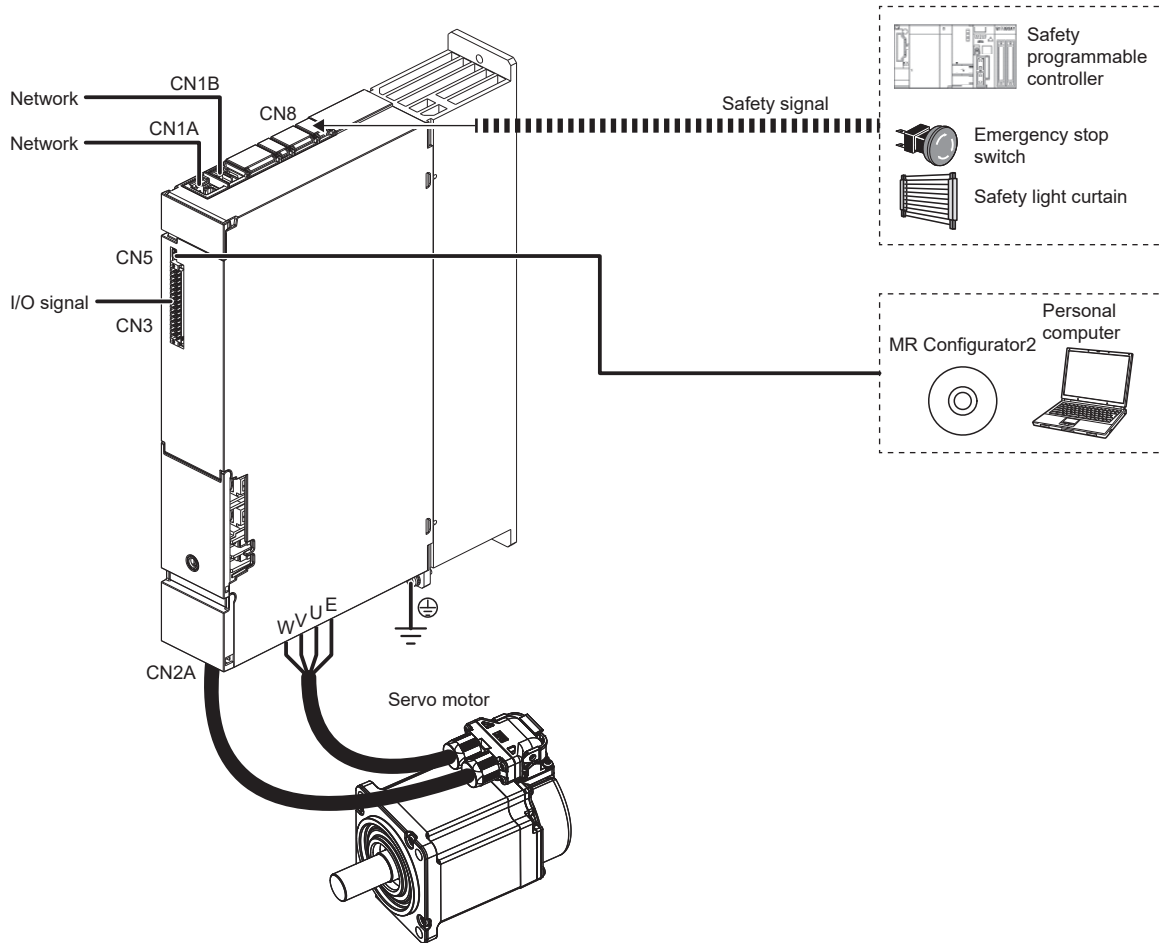

Safety sub-function control by network

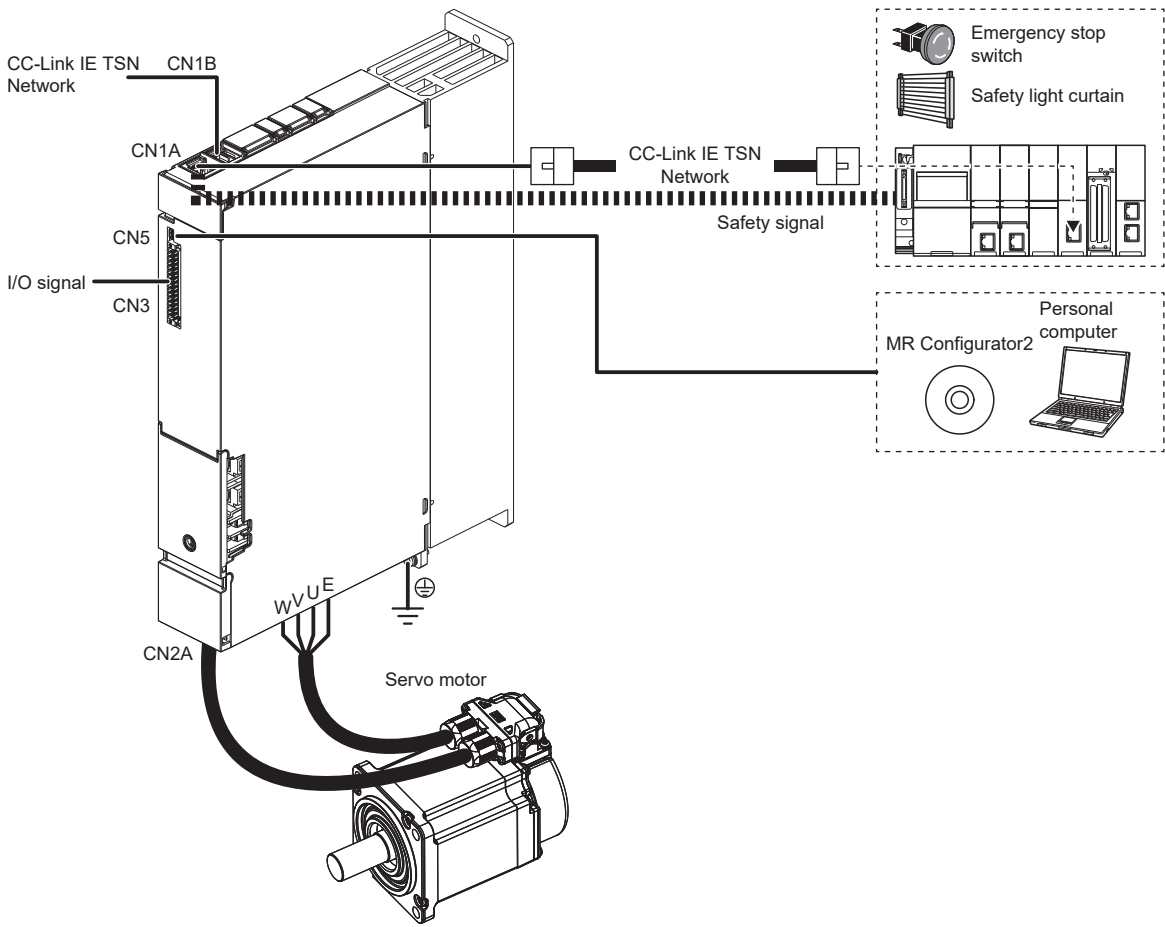

9.3 Specifications

For information on safety sub-function specifications, refer to "Functional safety" in the User's Manual (Introduction).

9.4 Connectors and pin assignments



The pin assignments of the connectors are as viewed from the cable connector wiring section.

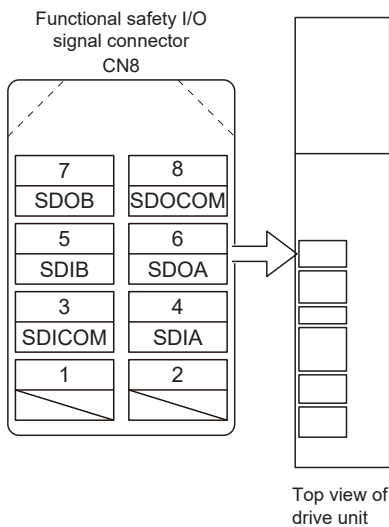

• Signal device explanations

Signal name	Connector pin No.	Description	I/O signal interface type
SDICOM	CN8-3	Common terminal for the SDIA and SDIB input signals.	DI-1
SDIA	CN8-4	Input the status of SDIA. Turning off SDIA: Open between SDIA and SDICOM. Turning on SDIA: Close between SDIA and SDICOM.	DI-1
SDIB	CN8-5	Input the status of SDIB. Turning off SDIB: Open between SDIB and SDICOM. Turning on SDIB: Close between SDIB and SDICOM.	DI-1
SDOCOM	CN8-8	Common terminal for the SDOA and SDOB output signals.	DO-1
SDOA	CN8-6	The signal that outputs the status assigned to SDOA. SDOA turned on: Closes between SDOA and SDOCOM. SDOA turned off: Opens between SDOA and SDOCOM.	DO-1
SDOB	CN8-7	The signal that outputs the status assigned to SDOB. SDOB turned on: Closes between SDOB and SDOCOM. SDOB turned off: Opens between SDOB and SDOCOM.	DO-1

9.5 Example I/O signal connections

This is only a connection example for CN8. Refer to the following for other connection examples.

☞ Page 48 Example I/O signal connections

Input signal

There is a delay of up to 5 ms from input to output.

For source input interface

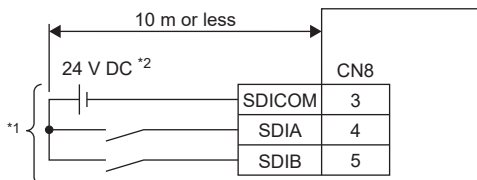

- *1 Separate the external input wiring into two routes, SDIA and SDIB.
- *2 Supply 24 V DC $\pm 10\%$ to interfaces from an external source. If all the I/O points have been used there must be a total current capacity of 0.2 A remaining. Reducing the number of I/O points decreases the current capacity. Refer to section 9.6 for information on the voltages required for interfaces. Although the diagram shows the input signal and the output signal each using a separate 24 V DC power supply for illustrative purposes, the system can be configured to use a single 24 V DC power supply.

For sink input interface

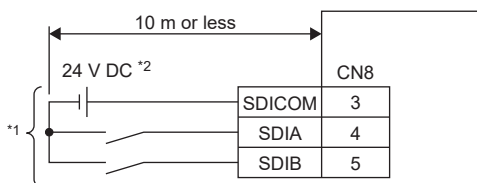

- *1 Separate the external input wiring into two routes, SDIA and SDIB.
- *2 Supply 24 V DC $\pm 10\%$ to interfaces from an external source. If all the I/O points have been used there must be a total current capacity of 0.2 A remaining. Reducing the number of I/O points decreases the current capacity. Refer to section 9.6 for information on the voltages required for interfaces. Although the diagram shows the input signal and the output signal each using a separate 24 V DC power supply for illustrative purposes, the system can be configured to use a single 24 V DC power supply.

Output signal

For source output interface

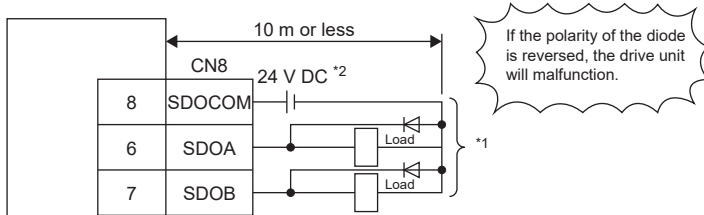

- *1 Separate the external output wiring into two routes, SDOA and SDOB.
- *2 Supply 24 V DC $\pm 10\%$ to interfaces from an external source. If all the I/O points have been used there must be a total current capacity of 0.2 A remaining. Reducing the number of I/O points decreases the current capacity. Refer to section 9.6 for information on the voltages required for interfaces. Although the diagram shows the input signal and the output signal each using a separate 24 V DC power supply for illustrative purposes, the system can be configured to use a single 24 V DC power supply.

For sink output interface

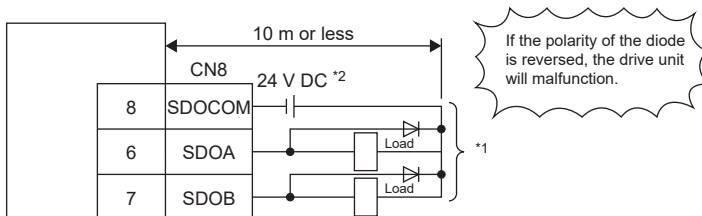

- *1 Separate the external output wiring into two routes, SDOA and SDOB.
- *2 Supply 24 V DC $\pm 10\%$ to interfaces from an external source. If all the I/O points have been used there must be a total current capacity of 0.2 A remaining. Reducing the number of I/O points decreases the current capacity. Refer to section 9.6 for information on the voltages required for interfaces. Although the diagram shows the input signal and the output signal each using a separate 24 V DC power supply for illustrative purposes, the system can be configured to use a single 24 V DC power supply.

9.6 Connecting I/O interfaces

Refer to this section before connecting I/O interfaces to external devices.

Source input

This is an input circuit in which the anode of the photocoupler is the input terminal. Transmit signals from a source (open-collector) transistor output, relay switch, etc.

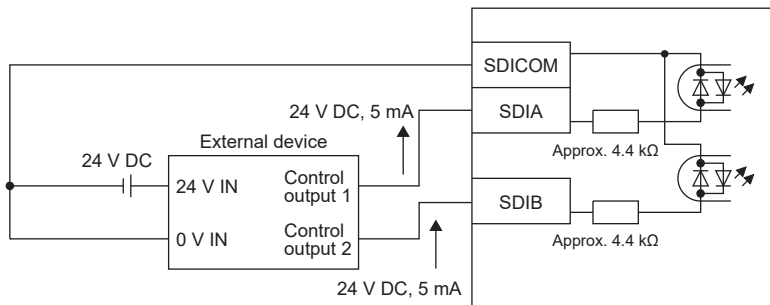

Sink input

This is an input circuit in which the photocoupler cathode side is the input terminal. Transmit signals from a sink (open-collector) type transistor output, relay switch, etc.

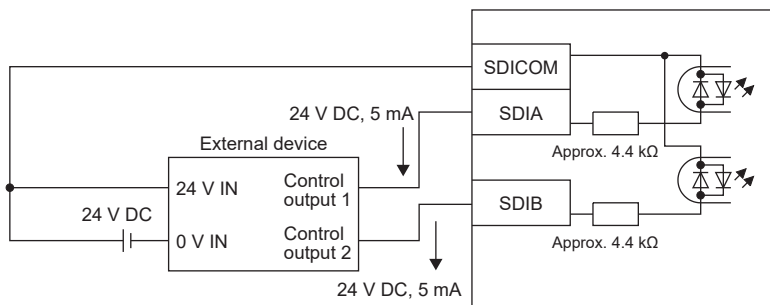

9.7 Wiring the SBC output

Point

This function only guarantees that the power supply for the mechanical brake is correct. It cannot detect brake wear. Check the mechanical brake periodically to ensure it is functioning correctly.

To use SBCS (SBC output), connect it to the electromagnetic brake of the servo motor. Wire the system so that the electromagnetic brake activates when SBCS (SBC output) turns off. It is not necessary to use MBR (electromagnetic brake interlock) of the drive unit. For information on the operation sequence when the SBC function is used, refer to "SBC function" in the following manual.

MR-J5 User's Manual (Function)

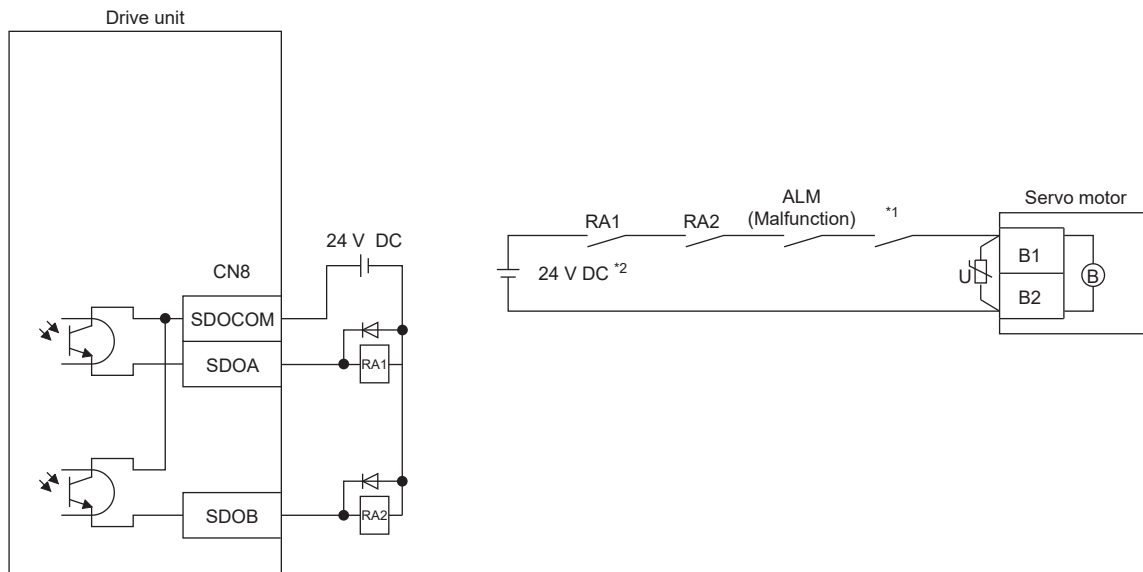

*1 Configure a circuit which interlocks with an emergency stop switch to shut off.

*2 Do not use the 24 V DC interface power supply for the electromagnetic brake.

9.8 Noise reduction techniques

This section provides information on measures that prevent the drive unit malfunctioning when it is installed next to peripheral devices that emit a large amount of noise.

Ground shielded cables close to the drive unit. Ensure that the part of the cable before the grounding point does not induce electromagnetic noise to the section of the cable after the grounding point. Strip part of the shielded cable, then ground the exposed portion of the cable on a large surface of the cabinet. A metal cable clamp can also be used to ground the cable (shown below). Mask the painted internal wall of the cabinet that touches the cable clamp.

- Exposed shield

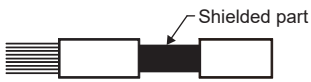

- Grounding the shield

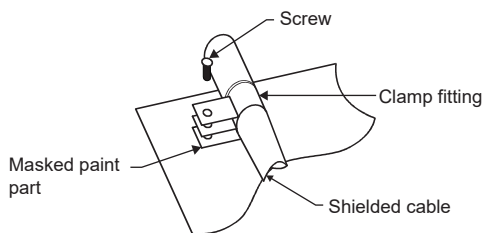

Ground the both ends of the CN8 cable with the cable clamp. The shield length from the drive unit to the cable clamp should be within 30 cm.

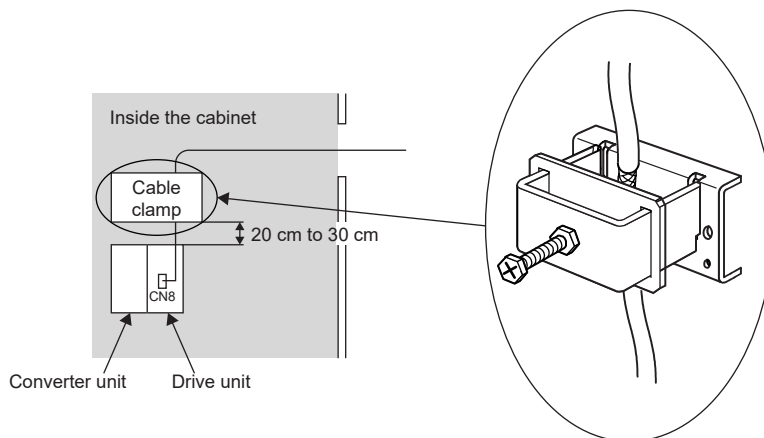

9.9 Example of connection with other devices

The following are examples of the MR-J5D1-_G_.

Safety sub-function control by input device

This figure shows the connection that allows execution of safety sub-functions from the safety controller using the input device assigned to pins of the CN8 connector.

The safety level Category 4 PL e, SIL 3 can be achieved with input signal diagnostics.

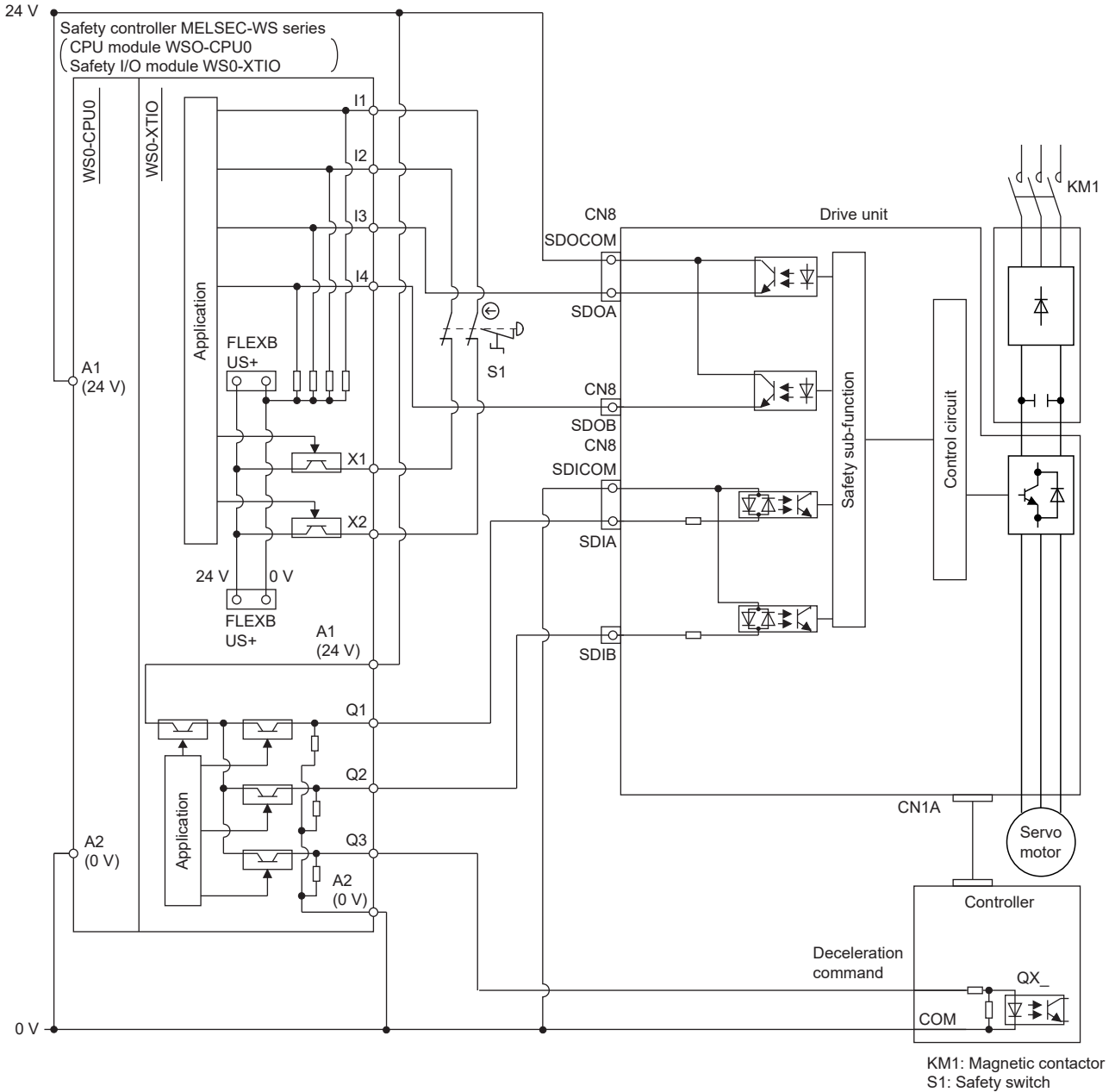

Safety sub-function control by network

This figure shows connection that allows execution of safety sub-functions via CC-Link IE TSN Network. Wiring can be reduced using this method.

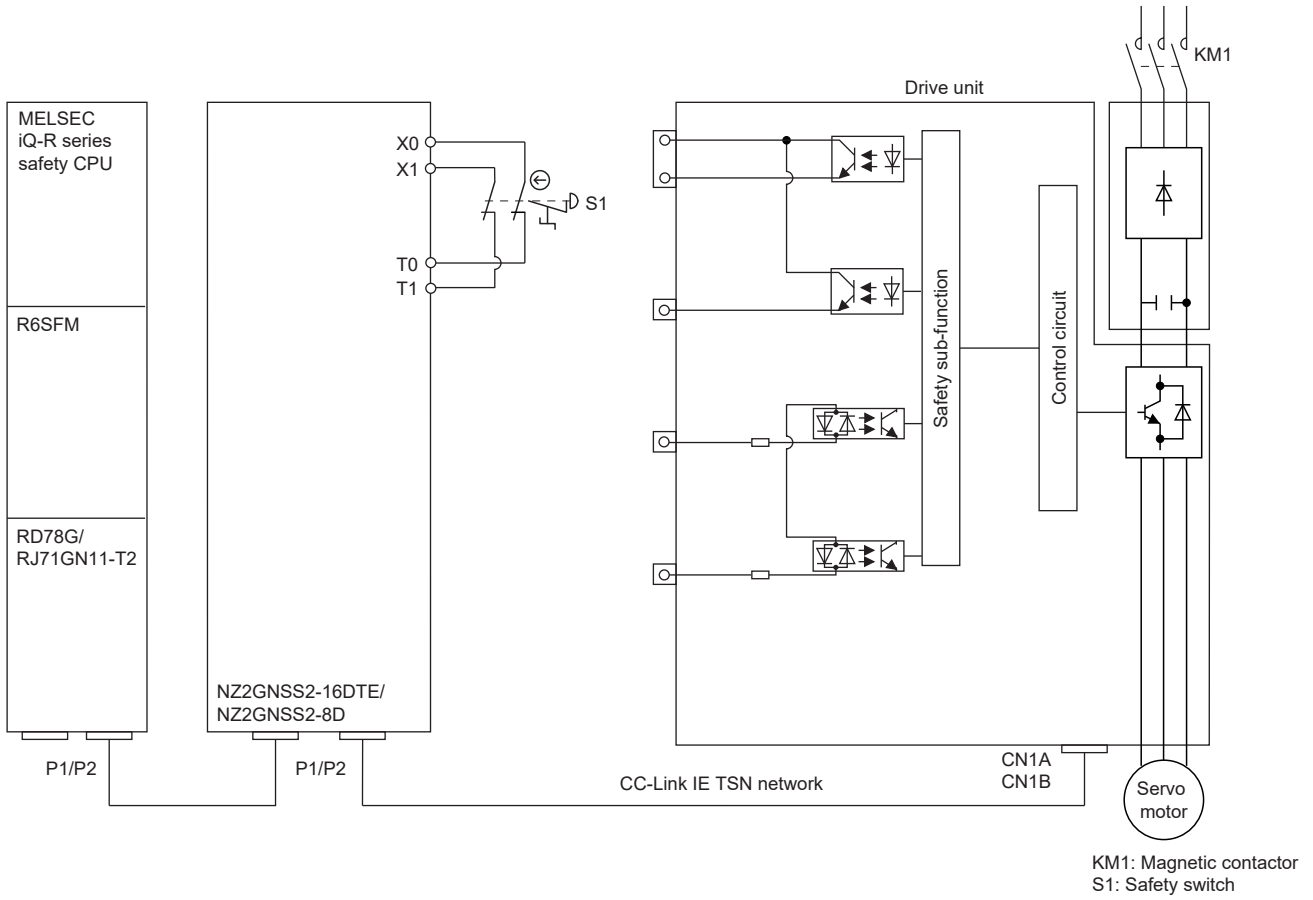

10 USING A FULLY CLOSED LOOP SYSTEM

10.1 Precautions

- A fully closed loop system cannot be used for a 3-axis drive unit. If the fully closed loop system is enabled for a 3-axis drive unit, [AL. 037 Parameter error] occurs.
- A fully closed loop system can be used in the position mode and positioning mode.
- Select a load-side encoder of which the number of load-side encoder pulses per servo motor revolution satisfies the following conditions.
 $4096 (2^{12}) \leq \text{Number of load-side encoder pulses per servo motor revolution} \leq 67108864 (2^{26})$
- Load-side encoders support HK series servo motors and linear scale and A/B/Z-phase differential output type encoders. For load-side encoders that can be used, contact your local sales office.
- When a fully closed loop system is used for a 1-axis drive unit, if a communication cycle shorter than 125 μs is set, [AL. 09E.A Communication cycle setting warning] occurs.
- When a fully closed loop system is used for a 2-axis drive unit, if a communication cycle shorter than 250 μs is set, [AL. 09E.A] occurs.
- A/B/Z-phase differential output rotary encoders cannot be connected to the servo motor side.

Restrictions when a fully closed loop system is configured with a 2-axis drive unit

- A/B/Z-phase differential output type encoders cannot be used.
- Only the load-side encoders and servo motor encoders with the two-wire type communication method can be used. The load-side encoders and servo motor encoders with the four-wire type communication method cannot be used.
- When HK series rotary servo motors are used for drive and load-side encoders, four-wire type encoder cables cannot be used.

10.2 Functions and configuration

Outline

Either a semi closed loop system or a fully closed loop system can be selected as a control method for this drive unit. In addition, the semi closed loop control, fully closed loop control, or dual feedback control can be selected by the setting of [Pr. PE08 Fully closed loop dual feedback filter] in the fully closed loop system.

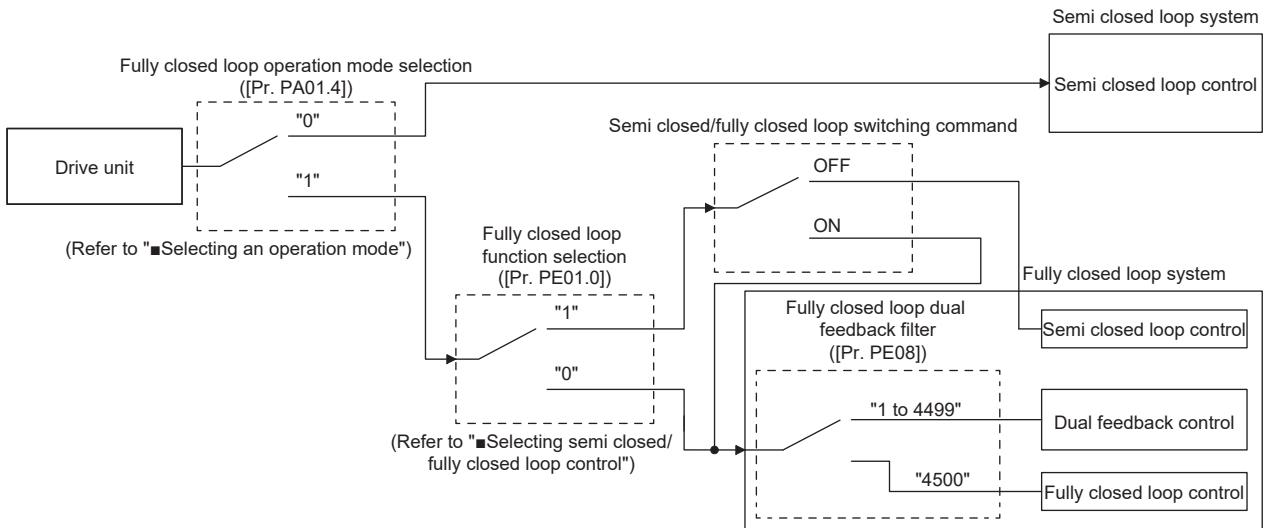

The following table lists the characteristics of each control method.

Control	Description	
Semi closed loop control	Feature	The position is controlled with servo motor-side information.
	Advantage	Because this control method is not susceptible to machine resonance, it can increase the gain of the drive unit and shorten the settling time.
	Disadvantage	Even when the servo motor side is stopped, the load side may vibrate or accuracy at the load side may not be achieved.
Dual feedback control	Feature	The position is controlled with servo motor-side information and load-side information.
	Advantage	The gain during operation can be increased and thus the settling time can be shortened by switching the information type to control the position as follows: the servo motor-side information during operation and the load-side information during stops. When the servo motor stops, it stops with the accuracy at the load side.
Fully closed loop control	Feature	The position is controlled with load-side information.
	Advantage	Accuracy at the load side is achieved not only during stops, but also during operation.
	Disadvantage	Because this control method is susceptible to machine resonance, it may be unable to increase the gain of the drive unit.

Function block diagram

Fully closed loop system block diagram

A fully closed loop system block diagram is shown below. For a fully closed loop system, the position is controlled in the units of the load-side encoder.

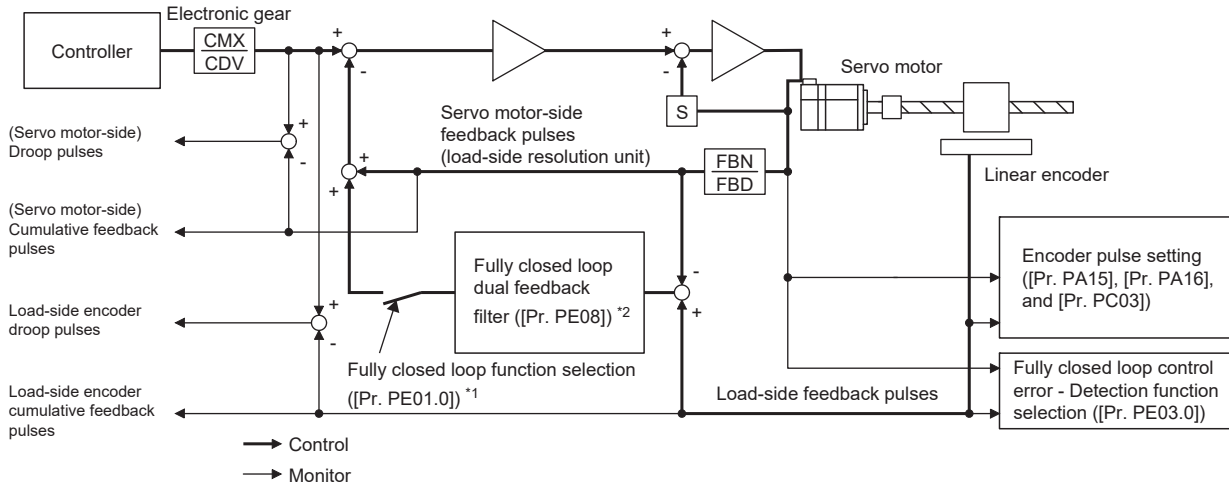

- *1 A switch between semi closed loop control and fully closed loop control can be set with [Pr. PE01.0 Fully closed loop function selection]. For semi closed loop control, regardless of whether the servo motor stops or rotates, the position is always controlled based on servo motor encoder position information.
- *2 For fully closed loop control, dual feedback control, which combines servo motor feedback signals and load-side encoder feedback signals, can be enabled with [Pr. PE08 Fully closed loop dual feedback filter]. When dual feedback control is enabled, the control performance is improved by switching the control method to fully closed loop control when the servo motor is stopped and to semi closed loop control when the servo motor is operating. When [Pr. PE08] is set to "4500", fully closed loop control is always enabled.

Dual feedback filter equivalent block diagram

The following shows a dual feedback filter equivalent block diagram for dual feedback control.

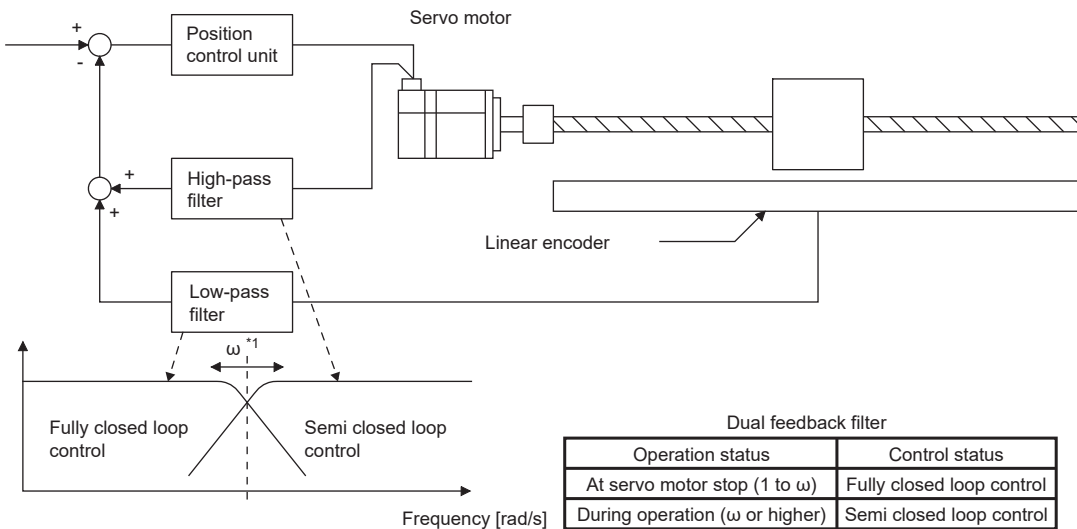

- *1 Set " ω " (dual feedback filter band) with [Pr. PE08 Fully closed loop dual feedback filter].

Operation mode and load-side encoder combinations

Refer to the following table for availability of the fully closed loop system.

Load-side encoder	[Pr. PA01.1 Operation mode selection]
	"0" Standard control mode
Linear encoder	<input type="radio"/>
Rotary servo motor manufactured by Mitsubishi Electric	<input type="radio"/>
A/B/Z-phase differential output rotary encoder	<input type="radio"/> *1

*1 It can be used with a 1-axis drive unit. If a 2-axis drive unit is used, [AL. 070] occurs.

For a 2-axis drive unit, use a two-wire type encoder cable. Note that four-wire type serial interface-compatible encoders and A/B/Z-phase pulse train interface-compatible encoders cannot be used.

System architecture

For linear encoders

■ 1-axis drive unit

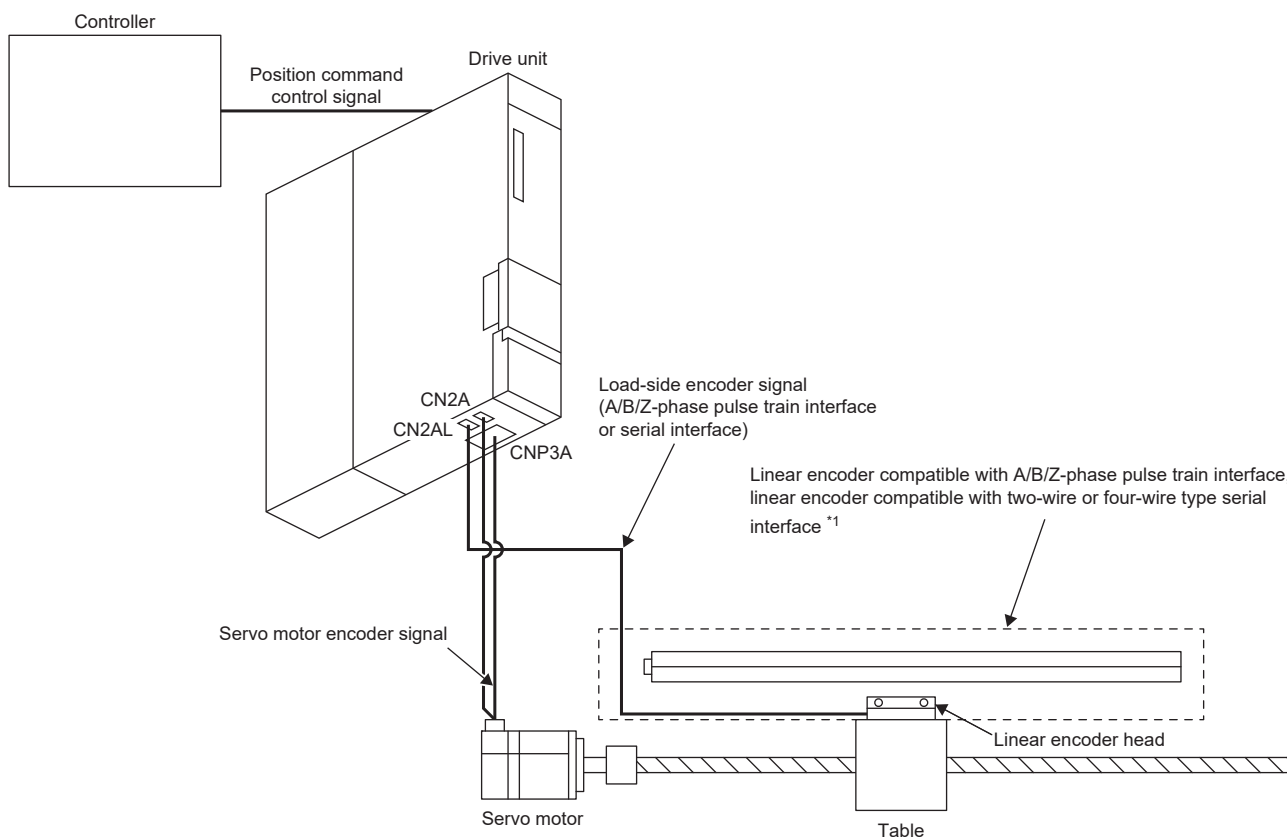

*1 When using an absolute position linear encoder, an absolute position detection system can be supported. In that case, batteries are unnecessary.

■2-axis drive unit

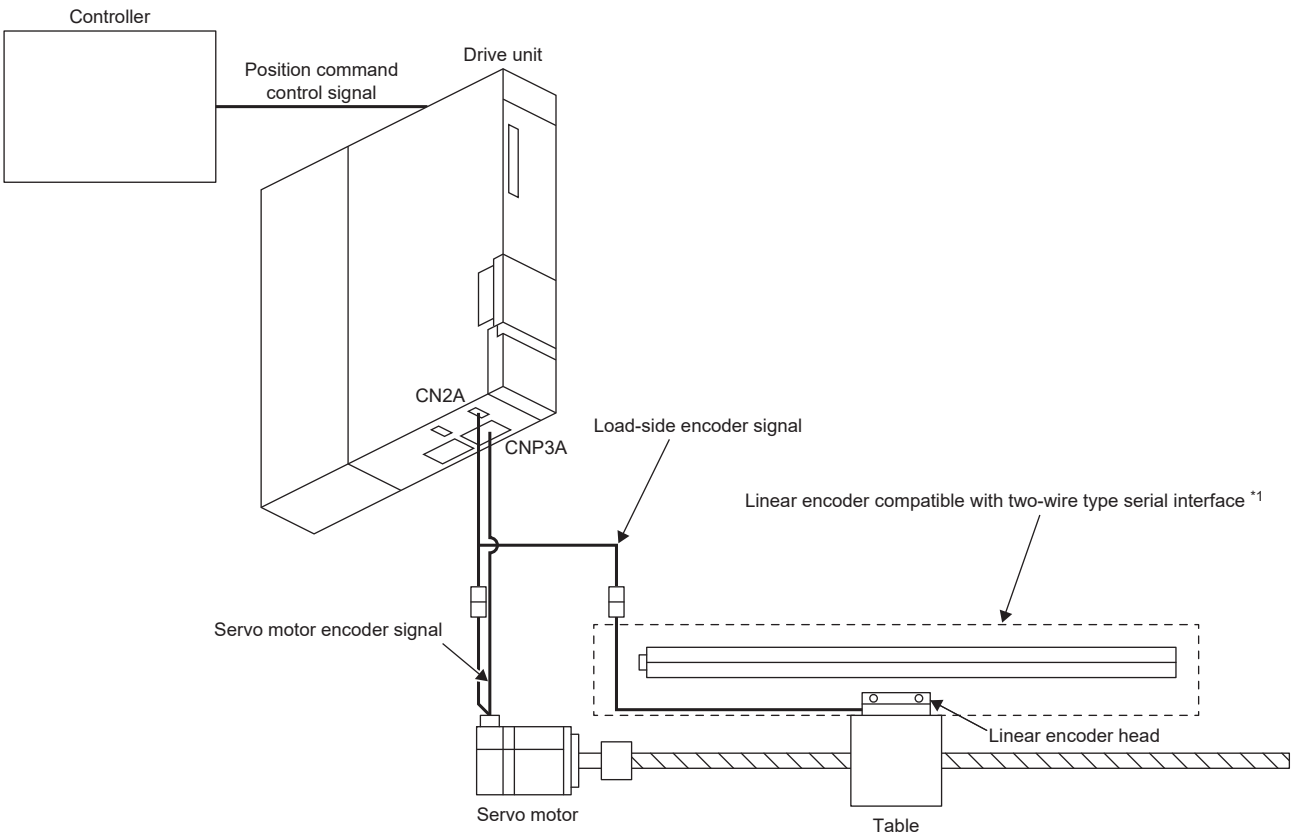

*1 When using an absolute position linear encoder, an absolute position detection system can be supported. In that case, batteries are unnecessary.

For rotary encoders

■1-axis drive unit

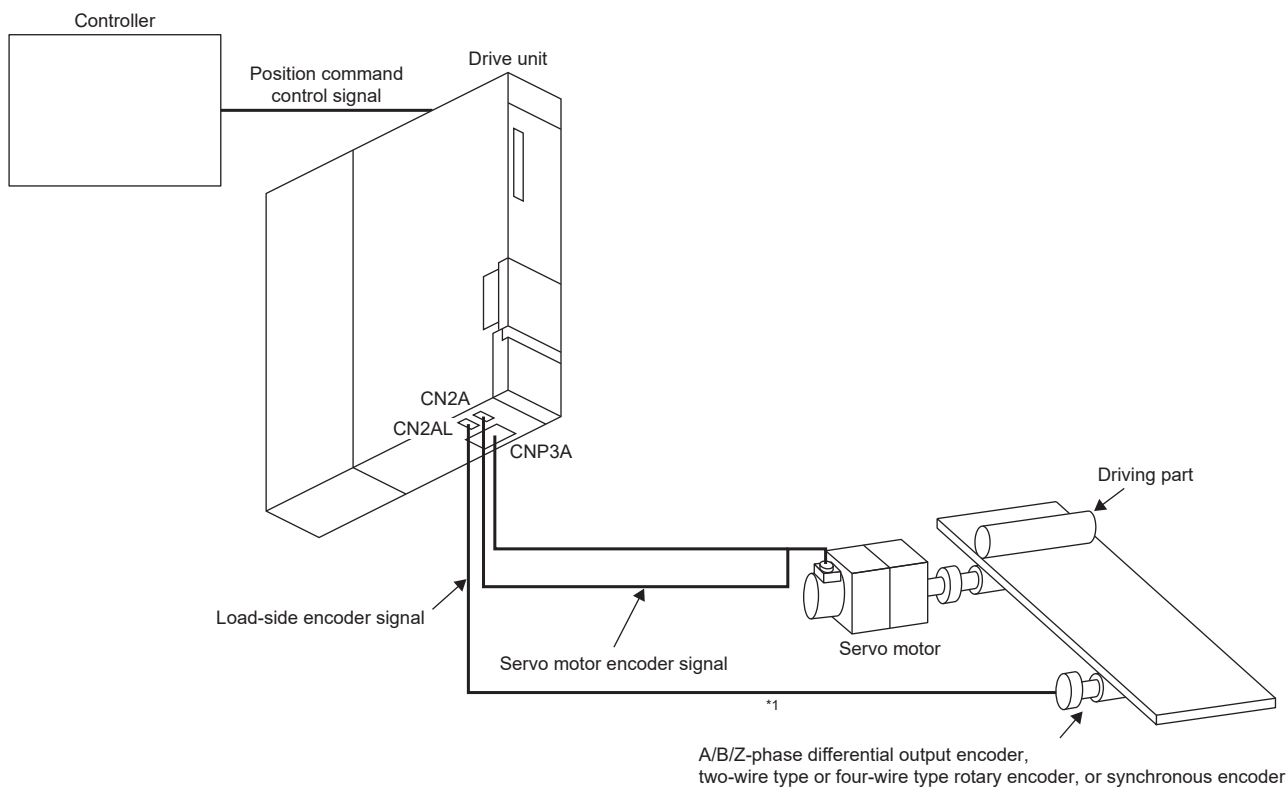

*1 When using an HK-KT servo motor, an absolute position detection system can be supported without using batteries.

■2-axis drive unit

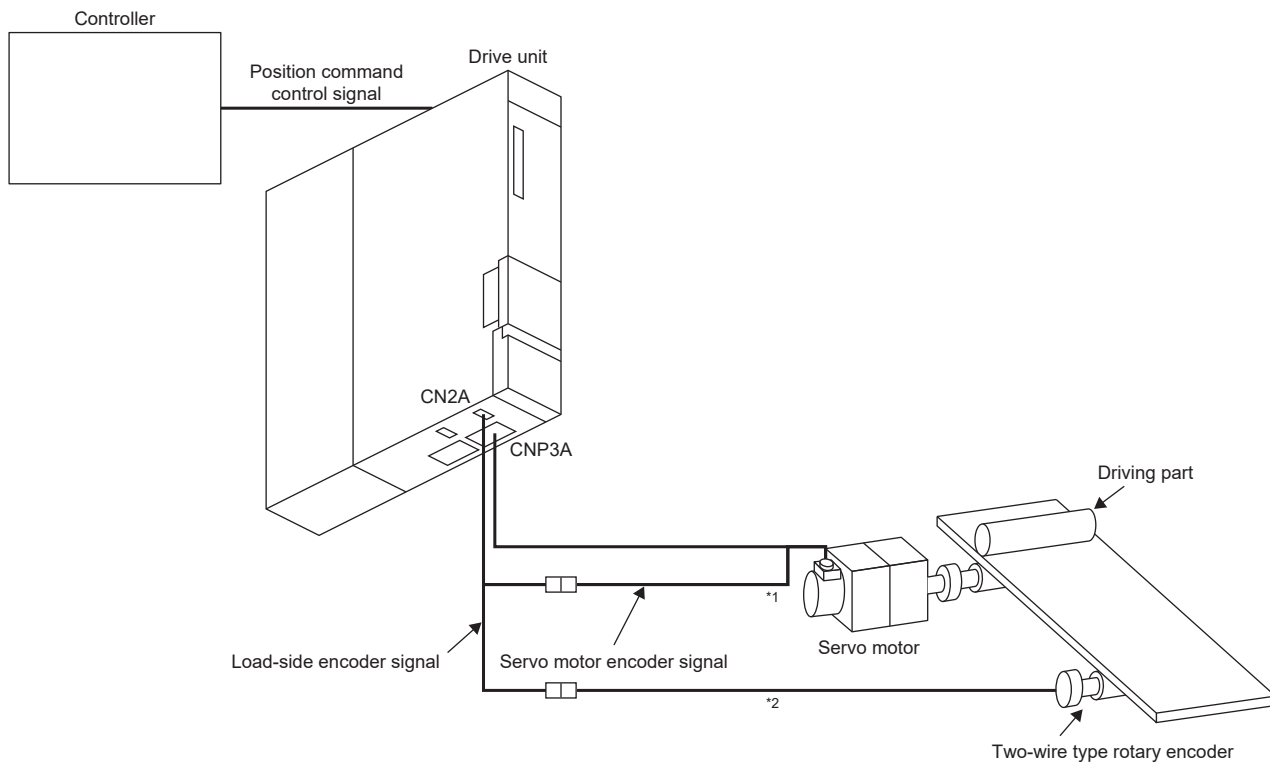

*1 Use two-wire type encoder cables. Four-wire type encoder cables cannot be used.

*2 When using an HK-KT servo motor, an absolute position detection system can be supported without using batteries.

10.3 Signals and wiring

Point

- Be sure to use the load side encoder cables specified in this section. Using products other than those specified may cause a malfunction.
- Contact the manufacturer of the load-side encoder being used for information on specifications, performance, and guarantees.

Encoder cable configuration diagram

Configuration diagrams of the drive unit and load-side encoder are shown below. The cable to be used differs depending on the load-side encoder.

Encoder cable configuration diagram for linear encoders

For linear encoder cables, refer to "OPTION CABLES/CONNECTOR SETS" in the following manual.

MR-J5 Partner's Encoder User's Manual

The encoder cable to be used differs depending on the load-side encoder.

1-axis drive unit

The linear encoder can be connected without using an MR-J4FCCBL03M branch cable. In addition, a four-wire type linear encoder can also be used.

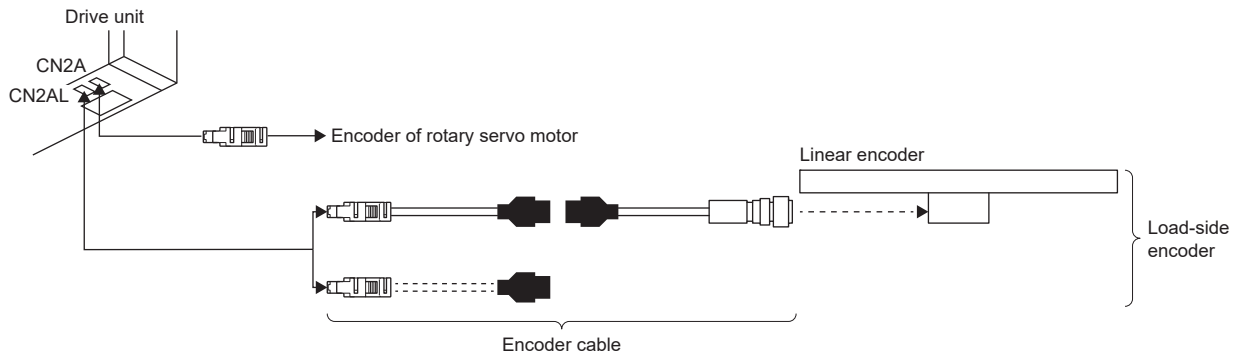

2-axis drive unit

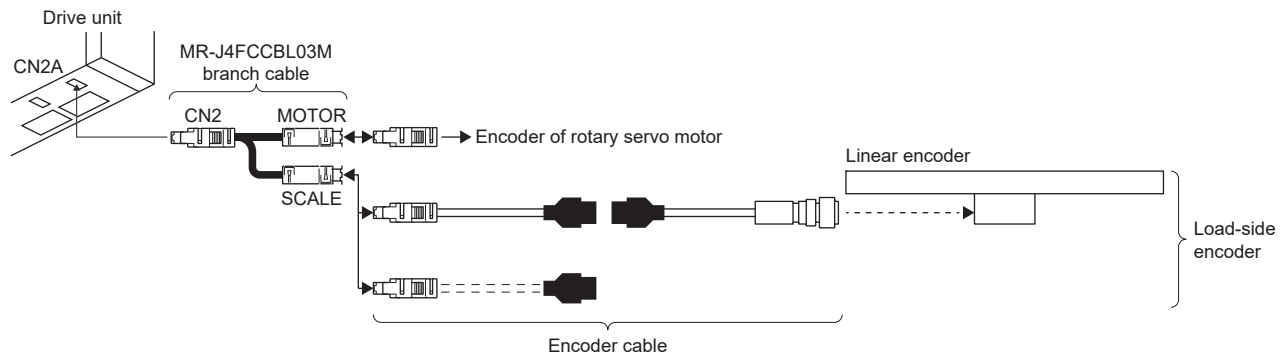

Encoder cable configuration diagram for rotary encoders

Point

- When using a rotary encoder as the load-side encoder, use an HK-KT servo motor as the encoder.
- Use a two-wire type encoder cable.
- When using an A/B/Z-phase differential output rotary encoder, refer to "A/B/Z-phase differential output type encoder" in the following manual.

MR-J5 Partner's Encoder User's Manual

For cables for rotary encoders, refer to "Motor cables/connector sets" and "Encoder cable" in the following manual.

Rotary Servo Motor User's Manual (HK series)

1-axis drive unit

The linear encoder can be connected without using an MR-J4FCCBL03M branch cable. In addition, a four-wire type linear encoder can also be used.

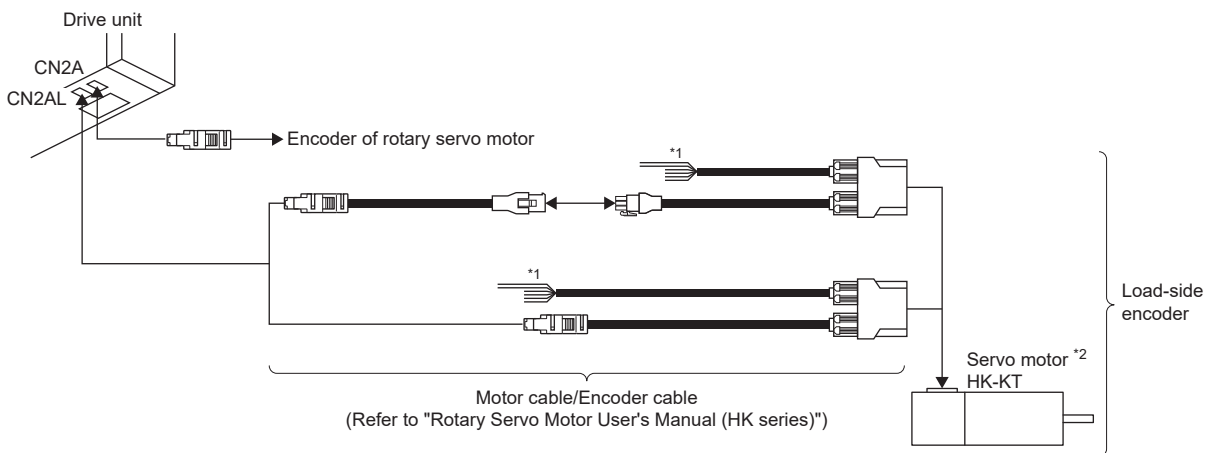

*1 When the motor type of the servo motor is "HK-KT_W", a maximum of 240 V is output from the power cable, and when the motor type is "HK-KT_4_W", a maximum of 480 V is output. Insulation is therefore required. Apply insulation protection according to the maximum voltage to U, V, W, and each grounding wire. Do not disconnect the power cable during the insulation protection.

*2 Use the servo motor in the range not exceeding the maximum servo motor speed described in "Standard specifications list" in the "Rotary Servo Motor User's Manual (HK series)".

2-axis drive unit

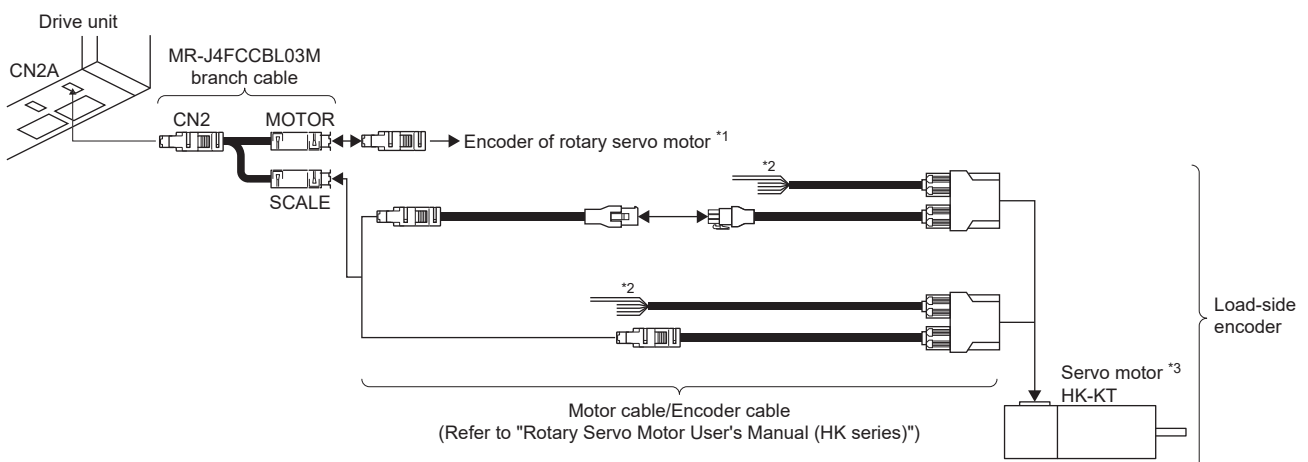

*1 Use two-wire type encoder cables. Four-wire type encoder cables cannot be used.

*2 When the motor type of the servo motor is "HK-KT_W", a maximum of 240 V is output from the power cable, and when the motor type is "HK-KT_4_W", a maximum of 480 V is output. Insulation is therefore required. Apply insulation protection according to the maximum voltage to U, V, W, and each grounding wire. Do not disconnect the power cable during the insulation protection.

*3 Use the servo motor in the range not exceeding the maximum servo motor speed described in "Standard specifications list" in the "Rotary Servo Motor User's Manual (HK series)".

10.4 Startup

Servo parameter setting

Selecting a fully closed loop system

With the settings of [Pr. PA01], [Pr. PE01], and the controller control command, a control method can be selected as described in the following table.

[Pr. PA01.4 Fully closed loop operation mode selection]	[Pr. PE01.0 Fully closed loop function selection]	Semi closed loop control/fully closed loop control switching signal	Command unit	Control method	Absolute position detection system
"0" Semi closed loop system	—	—	Servo motor encoder unit	Semi closed loop control	○
"1" Fully closed loop system	"0"	—	Load-side encoder unit	Dual feedback control (Fully closed loop control)	○*1
		OFF		Semi closed loop control	×
	ON	Dual feedback control (Fully closed loop control)		×	

*1 Can be supported when the load-side encoder is an absolute position encoder.

■Selecting an operation mode

Select an operation mode.

- [Pr. PA01.4 Fully closed loop operation mode selection]

Setting value	Operation mode	Control unit
0	Semi closed loop system	Servo motor-side resolution unit
1	Fully closed loop system	Load-side resolution unit

■Selecting semi closed/fully closed loop control

Select semi closed/fully closed loop control.

- [Pr. PE01.0 Fully closed loop function selection]

0: Always enabled

1: Switching by fully closed loop selection command from the controller and by input device CLD (fully closed loop selection)*2

Fully closed loop selection		Control method
Command from controller	CLD (fully closed loop selection) *1	
OFF	OFF	Semi closed loop control
ON	OFF	
OFF	ON	Fully closed loop control
ON	ON	

*1 This is always off if the CLD (fully closed loop selection) is not assigned to an input device.

*2 If "1" is set in [Pr. PE01.0] while [Pr. PA03.0 Absolute position detection system selection] has been set to "1" (Enabled), [AL. 037.2 Parameter combination error] occurs.

This setting is enabled when "1" (fully closed loop control mode) is selected in [Pr. PA01.4 Fully closed loop operation mode selection].

Load-side encoder communication method selection

The communication method differs depending on the load-side encoder type.

For details on each load-side encoder communication method, refer to "External encoder connector" in the "User's Manual (Introduction)" and "Compatible encoder list" in the "MR-J5 Partner's Encoder User's Manual".

Select a cable to be connected to the CN2L connector with [Pr. PC26 Function selection C-8].

■[Pr. PC26.3 Load-side encoder cable communication method selection]

0: Two-wire type

1: Four-wire type

When using an A/B/Z-phase differential input interface, set "0".

The incorrect setting triggers [AL. 070] and [AL. 071].

■[Pr. PC27.2 ABZ phase input interface encoder ABZ phase connection assessment function selection]

Setting value	Non-signal detection alarm
	Z-phase-side non-signal alarm
0	[AL. 071.6]
1	Disabled

This servo parameter is enabled only when an A/B/Z-phase input interface encoder is used.

Setting the polarity of the load-side encoder

Precautions

- Do not set the incorrect direction in [Pr. PC27.0 Encoder pulse count polarity selection].

If the correct direction is not set, the encoder will not operate correctly, possibly causing a collision that results in an accident or damage to other devices.

- [Pr. PC27.0 Encoder pulse count polarity selection] is not related to [Pr. PA14 Travel direction selection].

Set this parameter according to the relationship between the servo motor and the linear encoder /rotary encoder.

- Do not set the incorrect direction in [Pr. PC27.0 Encoder pulse count polarity selection].

During the positioning operation, [AL. 042 Fully closed loop control error] may occur.

■Servo parameter

Set the polarity of the load-side encoder that is connected to the CN2L connector so that the CCW direction of the servo motor matches the increasing direction of the load-side encoder feedback.

- [Pr. PC27.0 Encoder pulse count polarity selection]

0: Load-side encoder pulse increasing direction in the servo motor CCW

1: Load-side encoder pulse decreasing direction in the servo motor CCW

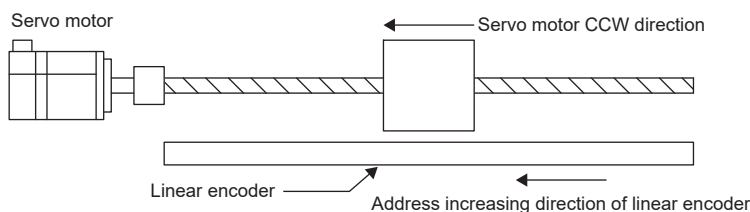

■Checking the feedback direction of the load-side encoder

Refer to the following for checking the feedback direction of the load-side encoder.

☞ Page 176 Checking position data of the load-side encoder

Setting the feedback pulse electronic gear

Precautions

If an incorrect value is set for the feedback pulse electronic gear ([Pr. PE04 Fully closed loop control - Feedback pulse electronic gear 1 - Numerator] or [Pr. PE05 Fully closed loop control - Feedback pulse electronic gear 1 - Denominator]), [AL. 037 Parameter error] may occur and prevent normal operation.

In addition, [AL. 042.8 Fully closed loop control error based on position deviation] may occur during the positioning operation. For servo motor-side encoder pulses, set the numerator [Pr. PE04] and denominator [Pr. PE05] of the electronic gear. Set the electronic gear so that the number of servo motor encoder pulses per servo motor revolution is converted into the number of load-side encoder pulses. The relation is as follows.

$$\frac{[\text{Pr. PE04}]}{[\text{Pr. PE05}]} = \frac{\text{The number of load-side encoder pulses per servo motor revolution}}{\text{The number of servo motor encoder pulses per servo motor revolution}}$$

Select a load-side encoder of which the number of load-side encoder pulses per servo motor revolution is within the following range.

$$4096 (2^{12}) \leq \text{Number of load-side encoder pulses per servo motor revolution} \leq 67108864 (2^{26})$$

■ Example settings of a ball screw (direct connection) with a linear encoder resolution of 0.05 μm

- Conditions

Servo motor resolution: 67108864 pulses/rev

Servo motor reduction ratio: 1/11

Ball screw lead: 20 mm

Linear encoder resolution: 0.05 μm

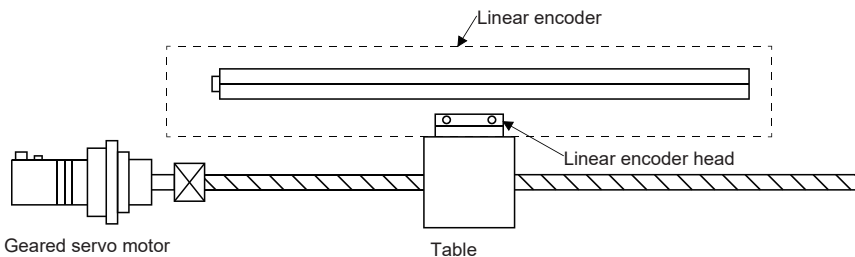

Calculate the number of linear encoder pulses per ball screw revolution.

Number of linear encoder pulses per ball screw revolution

= Ball screw lead/Linear encoder resolution

= 20 mm/0.05 μm = 400000 pulses

$$\frac{[\text{Pr. PE04}]}{[\text{Pr. PE05}]} = \frac{400000}{67108864} \times \frac{1}{11} = \frac{3125}{524288} \times \frac{1}{11}$$

■ Example settings when using a rotary encoder as the load-side encoder of a roll feeder

- Conditions

Servo motor resolution: 67108864 pulses/rev

Servo motor-side pulley diameter: 30 mm

Rotary encoder side pulley diameter: 20 mm

Rotary encoder resolution: 67108864 pulses/rev

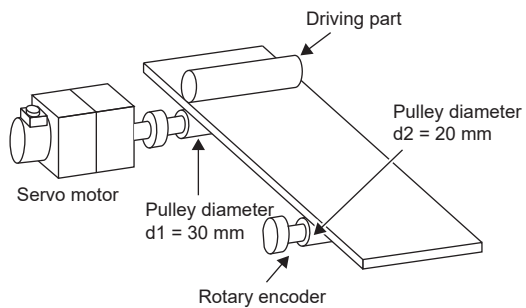

If the pulley ratio or reduction ratio is not one-to-one, calculate the electronic gear by taking that into consideration.

$$\frac{[\text{Pr. PE04}]}{[\text{Pr. PE05}]} = \frac{67108864 \times 30}{67108864 \times 20} = \frac{1}{1} \times \frac{3}{2}$$

Setting the fully closed loop dual feedback filter

Use auto tuning or a similar mode to adjust the gain in the same way as when using semi closed loop control while [Pr. PE08 Fully closed loop dual feedback filter] is being set to the initial value (setting value = 10).

Adjust the dual feedback filter while observing the servo operation waveforms with the graph function or a similar function of MR Configurator2.

The operation status of the dual feedback filter varies depending on the setting value as shown below.

Setting value of [Pr. PE08]	Control mode	Vibration	Settling time
1 to 4499	Dual feedback	Hardly occurs to Easily occurs	Longer to shorter
4500	Fully closed	—	—

When the setting value for the dual feedback filter is increased, the settling time becomes shorter. However the vibration of the servo motor will be larger because the servo motor becomes susceptible to the vibrations of the load-side encoder.

For the dual feedback filter, set a value that is equal to or smaller than a half of the setting value for PG2.

- To shorten the settling time: Increase the value for the dual feedback filter.

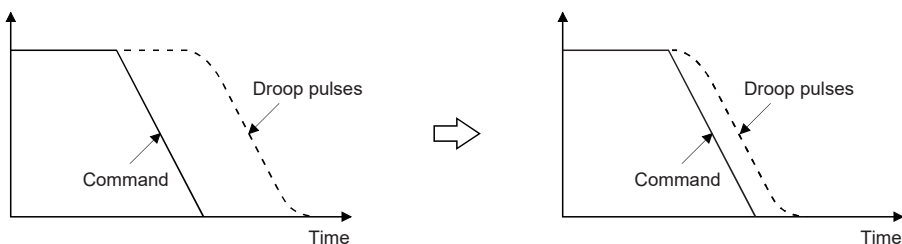

- To suppress vibration: Decrease the value for the dual feedback filter.

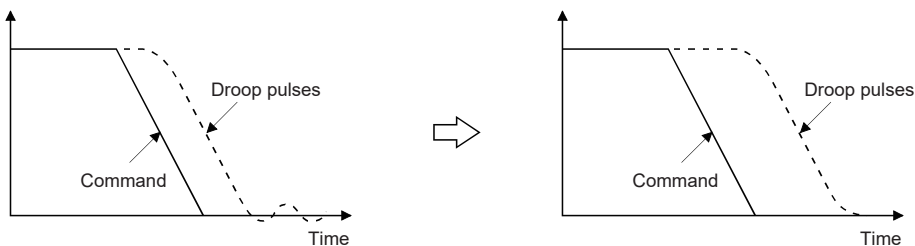

Load-side encoder resolution setting

When using an A/B/Z-phase differential output rotary encoder, set the resolution in [Pr. PE51 Load-side encoder resolution setting].

When using an A/B/Z-phase differential output linear encoder, set [Pr. PE51] to "0".

- [Pr. PE51 Load-side encoder resolution setting]

Set the resolution of the A/B/Z-phase differential output rotary encoder used on the load-side.

When an A/B/Z-phase differential output type encoder is connected, the value set to this servo parameter is used to determine whether it is a rotary encoder or a linear encoder.

0: Linear encoders

Other than 0: Rotary encoders

Checking position data of the load-side encoder

Precautions

Depending on the check items, MR Configurator2 may be used. Refer to "Help" of MR Configurator2 for the data displayed on the MR Configurator2.

Check the load-side encoder mounting and parameter settings for any problems.

No.	Check item	Confirmation method and description
1	Reading the position data of the load-side encoder	When a load-side encoder that is installed and connected correctly is operated, the value for load side encoder cumulative feedback pulses is counted correctly. If the value is not counted correctly, the following are likely causes. (1) An alarm occurred. (2) The load-side encoder is not installed correctly. (3) The encoder cable is not wired correctly.
2	Reading the home position of the load-side encoder (reference mark, Z-phase)	If the home position (reference mark, or Z-phase) of the load-side encoder is in a normal condition (mounting, connection, etc.), the value of load-side encoder information 1 is cleared to 0 when the load-side encoder is moved to pass through the home position (reference mark, or Z-phase). If the value is not cleared, the following are likely causes. (1) The load-side encoder is not installed correctly. (2) The encoder cable is not wired correctly.
3	Checking the load-side encoder feedback direction (setting the polarity of the load-side encoder)	Move the device (load-side encoder) manually in servo-off status to confirm that the directions of the cumulative feedback pulses of the servo motor encoder (after taking the gear into consideration) and the load-side cumulative feedback pulses are matched. If the directions are mismatched, reverse the polarity.
4	Setting the electronic gear for the load-side encoder	When the servo motor and the load-side encoder move synchronously, the servo motor-side cumulative feedback pulses (after taking the gear into consideration) and load side encoder cumulative feedback pulses increase by the same amount. If the cumulative feedback pulses are mismatched, use the following procedure to review the settings of the fully closed loop control feedback electronic gear ([Pr. PE04 Fully closed loop control - Feedback pulse electronic gear 1 - Numerator] and [Pr. PE05 Fully closed loop control - Feedback pulse electronic gear 1 - Denominator]). (1) Check the servo motor-side cumulative feedback pulses (before taking the gear into consideration). (2) Check the load-side cumulative feedback pulses. (3) Check that the ratio of (1) to (2) mentioned above is the same as the feedback electronic gear ratio.

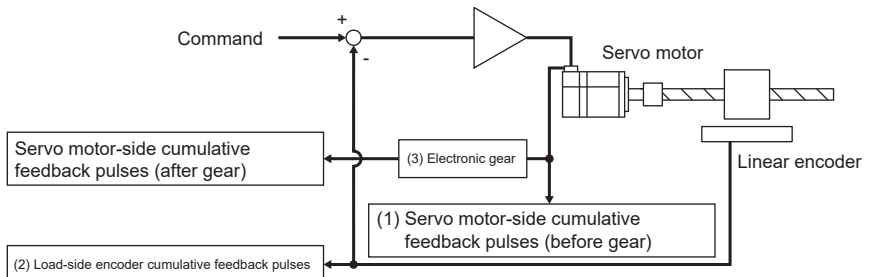

10.5 Basic functions

Homing

Homing is performed based on the load-side encoder feedback data regardless of the load-side encoder type.

It is irrelevant to the Z-phase position of the servo motor encoder.

The types and methods of homing are basically the same as in semi closed loop control.

Restriction

- In the case of homing with a dog signal, the home position (reference mark) must be passed through when an incremental type linear encoder is used, or the Z-phase must be passed through when a rotary encoder is used, during a period from a home position return start until the dog signal turns off.
- For the linear encoder, a home position (reference mark) of the linear encoder is necessary in the homing direction. In addition, place the proximity dog position one half of the rotation or more before the reference mark.

Precautions

To execute homing securely in the following example, start homing after moving the servo motor to LSN with the JOG operation.

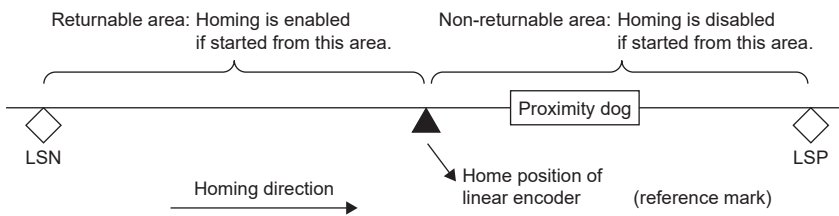

Reference home position

■ Absolute position linear encoder

The reference home position for an absolute position linear encoder is every position per servo motor revolution starting from the linear encoder home position (absolute position data = 0).

In the case of Method -1 (dog type homing), the nearest position after the proximity dog signal turned off is the home position. The linear encoder home position can be set to any position.

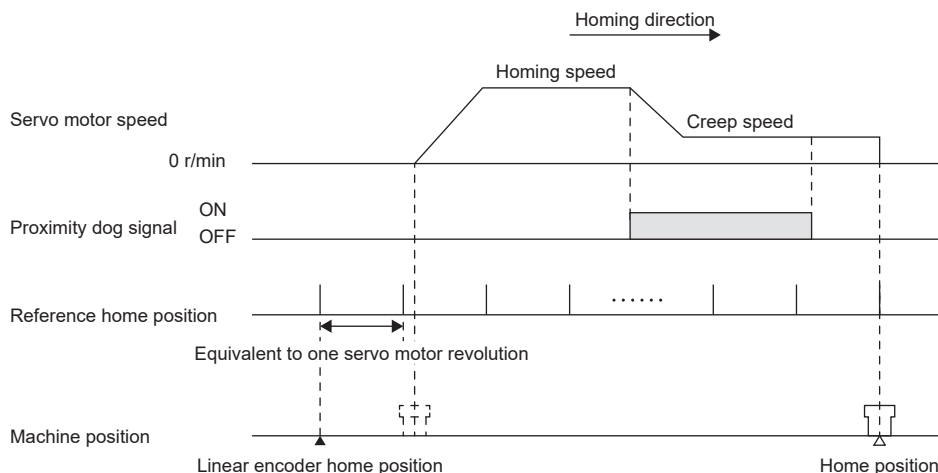

■ Incremental linear encoder

Precautions

- To execute homing securely, start homing after moving the servo motor to the opposite stroke end with the JOG operation from the controller or other methods.
- If the linear encoder home position (reference mark) does not exist on the incremental linear encoder, only the homing methods that do not use the Z-phase can be executed.
- Do not set multiple homing positions (reference marks).
- An interval for turning on home position (reference mark) signal of the linear encoder has a certain width.

(Specifications differ depending on the linear encoder.)

Example: When the Z-phase is recognized at startup

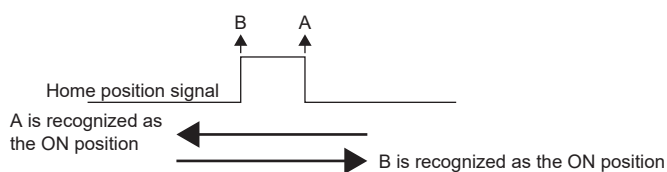

The position where the signal turns on depends on the direction in which the home position is passed through. In a case where homing is always required to be completed at the same position (such as dog type homing), start homing with the same direction.

The reference home position for an incremental linear encoder is every position per servo motor revolution starting from the first linear encoder home position which has been passed through after the power-on. (reference mark).

In the case of Method -1 (dog type homing), the nearest reference home position after the proximity dog signal rear end is detected is the home position.

- When the linear encoder home position (reference mark) exists in the homing direction

The position obtained by moving the home position shift distance from the linear encoder home position (reference mark) is set as the home position.

The following figure shows the operation of Homing method 34. The homing direction of Homing method 33 is opposite to that of Homing method 34.

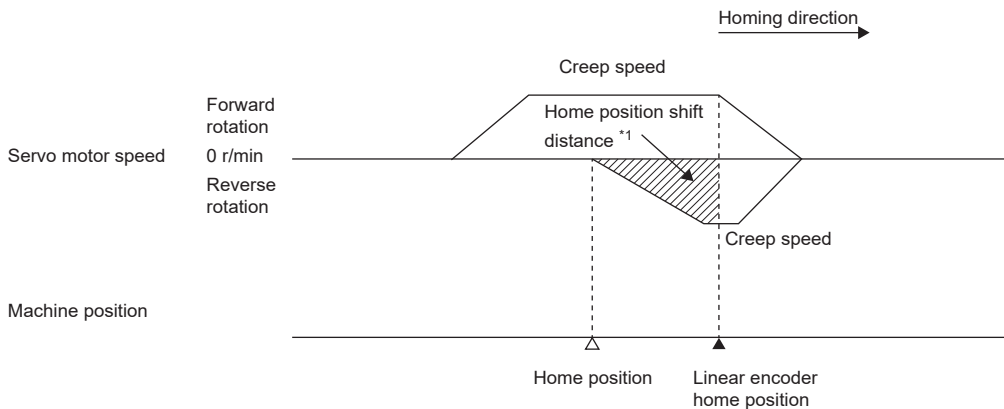

*1 Home position shift distance can be changed with [Pr. PT07 Home position shift distance].

When the stroke end is detected

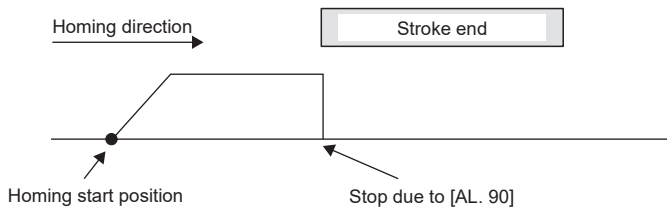

The following figure shows the operation of Homing method -11. The homing direction of Homing method -43 is opposite to that of Homing method -11.

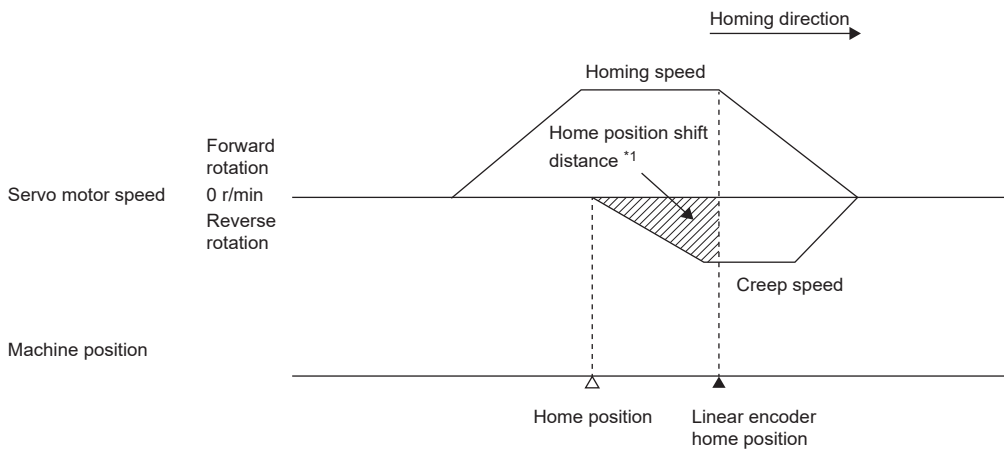

*1 Home position shift distance can be changed with [Pr. PT07].

When the servo motor returns at the stroke end

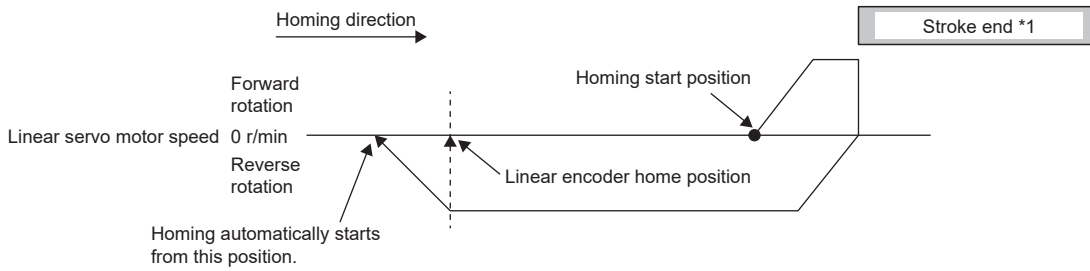

*1 This cannot be used with the software limit.

- When the linear encoder home position does not exist in the homing direction

If homing is performed from a position where the linear encoder home position does not exist in the homing direction, an error may occur depending on the homing method.

If an error occurs, change the homing method or temporarily move the servo motor to the stroke end opposite of homing with the JOG operation or other methods from the controller, then perform homing.

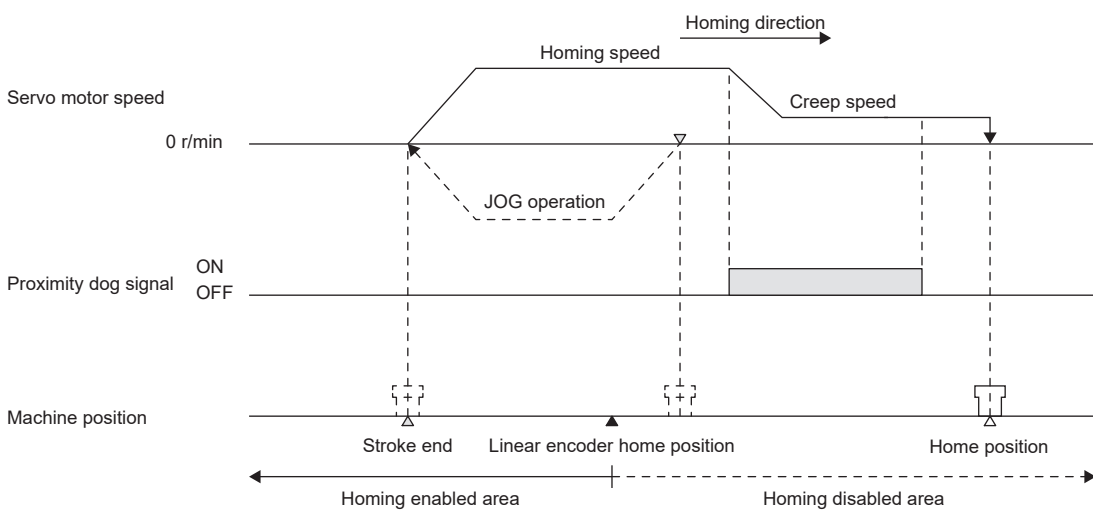

Rotary encoder of a serial communication servo motor

If using the rotary encoder of a serial communication servo motor as the load-side encoder, the home position is at the load side Z-phase position.

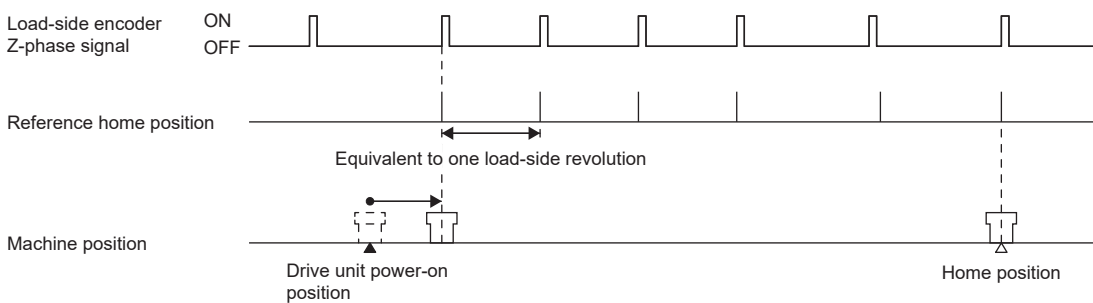

Operation from controller

The positioning operation from the controller is basically the same as in semi closed loop control.

Fully closed loop control error detection function

If fully closed loop control becomes unstable for some reason, the servo motor-side speed may increase abnormally. To detect this state and to stop operation, the fully closed loop control error detection function is used as a protective function. The fully closed loop control error detection function has two types of detection methods: speed deviation and position deviation. Errors are detected only when each method is enabled with [Pr. PE03.0 Fully closed loop control error - Detection function selection].

In addition, the detection level settings can be changed with [Pr. PE06 Fully closed loop control - Speed deviation error detection level] and [Pr. PE07 Fully closed loop control - Position deviation error detection level].

Fully closed loop control error - Detection function selection

Select the fully closed loop control error detection function.

Servo parameter	Description
PE03.0	Fully closed loop control error - Detection function selection 0: Disabled 1: Speed deviation error detection 2: Position deviation error detection 3: Speed deviation error detection and position deviation error detection (initial value)

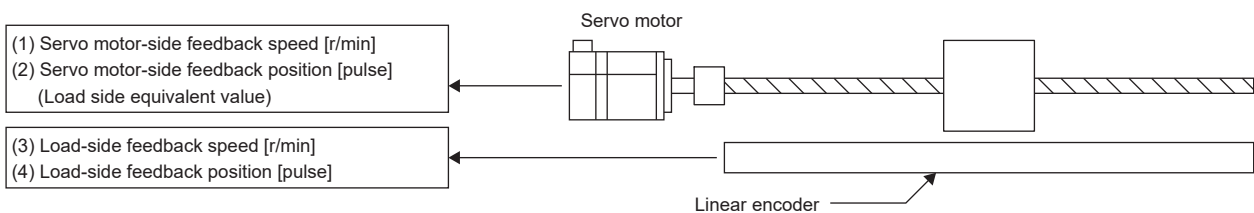

■Speed deviation error detection

Set [Pr. PE03.0 Fully closed loop control error - Detection function selection] to "1" (speed deviation error detection) to enable the speed deviation error detection.

Servo parameter	Description
PE03.0	Fully closed loop control error - Detection function selection 1: Speed deviation error detection

When the difference between the servo motor-side feedback speed (1) and the load-side feedback speed (3) is equal to or more than the value of [Pr. PE06 Fully closed loop control - Speed deviation error detection level] (1 r/min to permissible speed), [AL. 042.9 Servo control error based on speed deviation] occurs, and the servo motor stops.

The initial value for [Pr. PE06] is 400 r/min. Change the setting value as necessary.

■Position deviation error detection

Set [Pr. PE03.0 Fully closed loop control error - Detection function selection] to "2" (position deviation error detection) to enable the position deviation error detection.

Servo parameter	Description
PE03.0	Fully closed loop control error - Detection function selection 2: Position deviation error detection
PE03.1	Position deviation error - Detection method selection 0: Continuous detection 1: Detection only at stop (An error is detected if the command is "0".) 2: Detection only at stop 2 (An error is detected during servo-off or if the command is "0" while in servo-on state.)

Servo parameter	Description
PE10.1	Fully closed loop control - Position deviation error detection level - Unit selection 0: 1 [kpulse] unit 1: 1 [pulse] unit

When the difference between the servo motor-side feedback position (2) and the load-side feedback position (4) is equal to or more than the value of [Pr. PE07 Fully closed loop control - Position deviation error detection level] (1 kpulse to 20000 kpulses), [AL. 042.8 Servo control error based on position deviation] occurs, and the servo motor stops.

If the difference is equal to or more than the value of [Pr. PE07] at the command stop, [AL. 042.A Fully closed loop control error based on position deviation during command stop] occurs.

When [Pr. PE03.1 Position deviation error - Detection method selection] is set to "1" (Detection only at stop), only [AL. 042.A] is detected.

The initial value for [Pr. PE07] is 100 kpulses.

The setting unit for [Pr. PE07] can be changed with [Pr. PE10.1 Fully closed loop control - Position deviation error detection level - Unit selection].

Change the setting value as necessary.

■Detecting multiple deviation errors

Multiple deviation errors can be detected when [Pr. PE03.0 Fully closed loop control error - Detection function selection] is set as follows. Refer to the following for the error detection method.

☞ Page 181 Speed deviation error detection

☞ Page 182 Position deviation error detection

- [Pr. PE03.0 Fully closed loop control error - Detection function selection]

Setting value	Speed deviation error detection	Position deviation error detection
1	○	—
2	—	○
3	○	○

Fully closed loop control error - Reset selection

Select the reset condition of fully closed loop control errors.

■[Pr. PE03.3 Fully closed loop control error - Reset selection]

0: Reset disabled (reset by cycling the power or software reset)

1: Reset enabled

About MR Configurator2

With MR Configurator2, the servo parameters can be checked if set correctly, and the servo motor and the load-side encoder can be checked if operated properly.

This section explains the Fully Closed Loop Diagnosis screen.

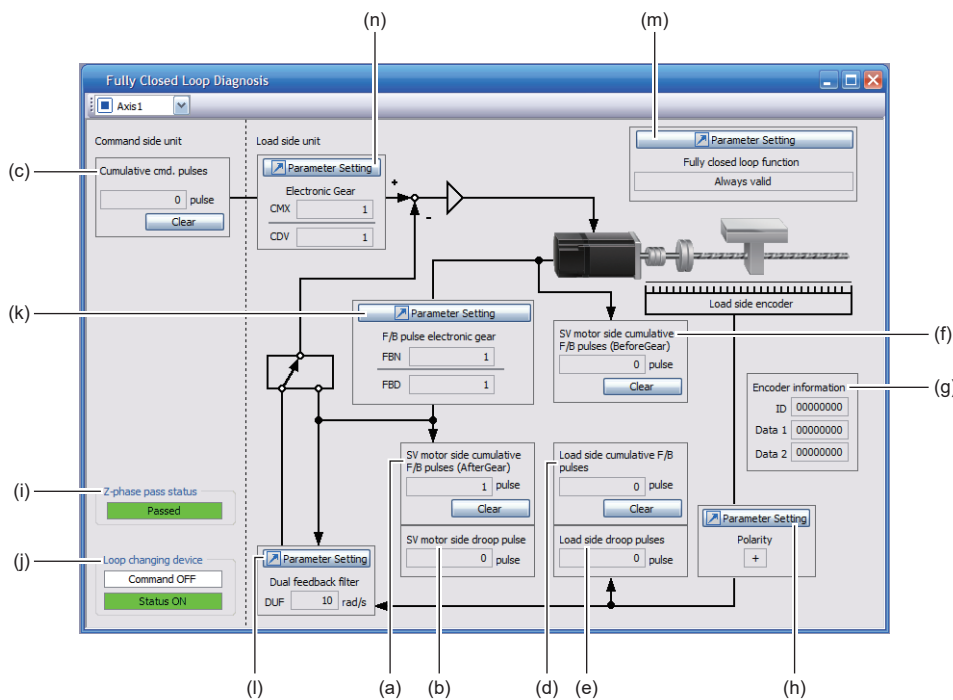

Symbol	Name	Explanation	Unit
(a)	Servo motor-side cumulative feedback pulses (after gear)	The feedback pulses from the servo motor encoder are counted and displayed. (load-side encoder unit) When the setting value exceeds 999999999, it starts from 0. Click "Clear" to reset the value to "0". In reverse rotation, the value is negative.	pulse
(b)	Servo motor-side droop pulses	Droop pulses of the deviation counter between a servo motor-side position and a command are displayed. In reverse rotation, the value is negative.	pulse
(c)	Cumulative command pulses	Position command input pulses are counted and displayed. Click "Clear" to reset the value to "0". Under reverse command, the value is negative.	pulse
(d)	Load-side encoder cumulative feedback pulses	The feedback pulses from the load-side encoder are counted and displayed. When the setting value exceeds 999999999, it starts from 0. Click "Clear" to reset the value to "0". In reverse rotation, the value is negative.	pulse
(e)	Load-side encoder droop pulses	Droop pulses of the deviation counter between a load-side position and a command are displayed. In reverse rotation, the value is negative.	pulse
(f)	Servo motor-side cumulative feedback pulses (before gear)	The feedback pulses from the servo motor encoder are counted and displayed. (Servo motor encoder unit) When the setting value exceeds 999999999, it starts from 0. Click "Clear" to reset the value to "0". In reverse rotation, the value is negative.	pulse
(g)	Encoder information	The load-side encoder information is displayed. The display contents differ depending on the load-side encoder type. <ul style="list-style-type: none"> • ID: The ID No. of the load-side encoder is displayed. • Data 1: For an incremental type linear encoder, the counter from powering on is displayed. For an absolute position type linear encoder, absolute position data is displayed. • Data 2: For the incremental type linear encoder, the distance (number of pulses) from the reference mark (Z-phase) is displayed. For the absolute position type linear encoder, "00000000" is displayed. 	—
(h)	Parameter Setting (Polarity)	"+" is displayed for the address increasing direction in the servo motor CCW direction, and "-" is displayed for the address decreasing direction in the servo motor CCW direction.	—

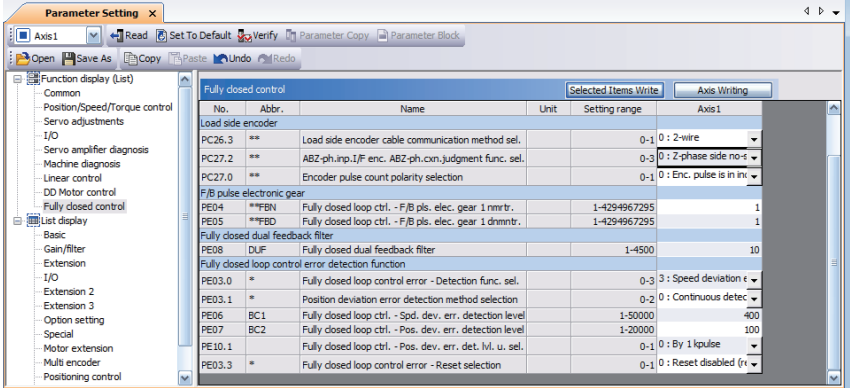
Symbol	Name	Explanation	Unit
(i)	Z-phase pass status	When the fully closed loop system is disabled, the Z-phase pass status of the servo motor encoder is displayed. When the fully closed loop system is enabled or when switching between semi closed loop control and fully closed loop control is enabled, Z-phase pass status of the load-side encoder is displayed.	—
(j)	Fully closed loop changing device	This item is displayed only when switching between semi closed loop control and fully closed loop control is enabled. The state of the semi closed loop control/fully closed loop control switching signal and the internal state when switching between semi closed loop control and fully closed loop control is enabled.	—
(k)	Parameter Setting (F/B pulse electronic gear)	With this servo parameter, the feedback pulse electronic gears ([Pr. PE04 Fully closed loop control - Feedback pulse electronic gear 1 - Numerator] and [Pr. PE05 Fully closed loop control - Feedback pulse electronic gear 1 - Denominator]) for servo motor encoder pulses can be displayed and set. ☞ Page 173 Setting the feedback pulse electronic gear	—
(l)	Parameter Setting (Dual F/B filter)	With this servo parameter, the band for [Pr. PE08 Fully closed loop dual feedback filter] can be displayed and set.	—
(m)	Parameter Setting (Fully closed loop function) [G]	The servo parameters for the fully closed loop control can be displayed and set. Click "Parameter Setting" to display the "Parameter Setting (Function display (List))" window. 	—
(n)	Parameter Setting (Electronic gear) [G]	Set the servo parameters for the electronic gears. [Pr. PA06 Electronic gear numerator], [Pr. PA07 Electronic gear denominator]	—

10.6 Options and peripheral equipment

MR-J4FCCBL03M branch cable

Use an MR-J4FCCBL03M branch cable to connect a rotary encoder and load-side encoder to the CN2 connector. When fabricating a branch cable by using an MR-J3THMCN2 connector set, refer to "Fabricating a branch cable for a fully closed loop system" in the following manual.

📖 MR-J5 Partner's Encoder User's Manual

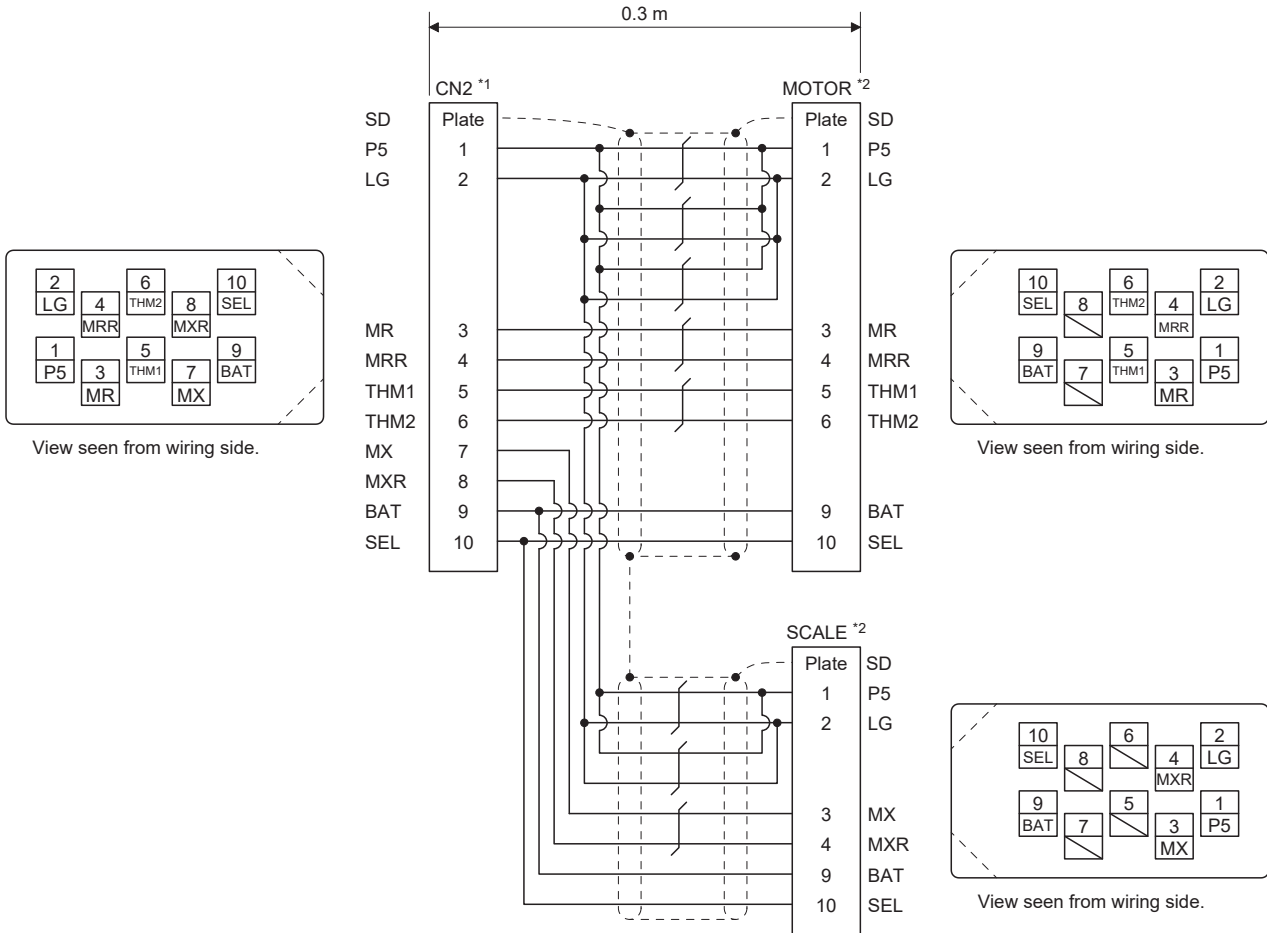

*1 Receptacle: 36210-0100PL, Shell kit: 36310-3200-008 (3M)

*2 Plug: 36110-3000FD, Shell kit: 36310-F200-008 (3M)

10.7 Absolute position detection system

Structure

An absolute position linear encoder is required to configure an absolute position detection system under fully closed loop control using a linear encoder.

In this case, an encoder battery need not be installed to the drive unit.

When a battery backup type rotary encoder is used, an absolute position detection system can be configured by installing the encoder battery to the drive unit.

When a batteryless rotary encoder is used, the encoder battery need not be mounted to the drive unit.

Restriction

- Use an absolute position type encoder for the load-side encoder.

Using an incremental type encoder triggers [AL. 037 Parameter error].

- Switching between semi closed loop control and fully closed loop control cannot be performed. Set [Pr. PE01.0 Fully closed loop function selection] to "0" (Always enabled).

If [Pr. PE01.0 Fully closed loop function selection] is set to "1" (switching by fully closed loop selection command from the controller and by input device CLD), [AL. 037 Parameter error] occurs.

- Use the encoder within the range of 32-bit absolute position data. When using the degree unit, the infinite feed function is enabled. For details, refer to "Infinite feed function" in the following manual.

 MR-J5 User's Manual (Function)

- When a linear encoder is used for the load-side encoder, absolute position-related alarms ([AL. 025 Absolute position erased]) and warnings ([AL. 092 Battery cable disconnection warning] and [AL. 09F Battery warning]) are not detected.
-

Precautions

When the absolute position detection system is configured with a rotary encoder, the battery life will be shorten because the current consumption is increased as the power from the battery is supplied to both the servo motor-side and the load-side encoder.

REVISIONS

*The manual number is given on the bottom left of the back cover.

Revision date	*Manual number	Description
June 2021	IB(NA)-0300548ENG-A	First edition

This manual confers no industrial property rights or any rights of any other kind, nor does it confer any patent licenses. Mitsubishi Electric Corporation cannot be held responsible for any problems involving industrial property rights which may occur as a result of using the contents noted in this manual.

© 2021 MITSUBISHI ELECTRIC CORPORATION

WARRANTY

Warranty

1. Warranty period and coverage

We will repair any failure or defect hereinafter referred to as "failure" in our FA equipment hereinafter referred to as the "Product" arisen during warranty period at no charge due to causes for which we are responsible through the distributor from which you purchased the Product or our service provider. However, we will charge the actual cost of dispatching our engineer for an on-site repair work on request by customer in Japan or overseas countries. We are not responsible for any on-site readjustment and/or trial run that may be required after a defective unit are repaired or replaced.

[Term]

For terms of warranty, please contact your original place of purchase.

[Limitations]

(1) You are requested to conduct an initial failure diagnosis by yourself, as a general rule.

It can also be carried out by us or our service company upon your request and the actual cost will be charged. However, it will not be charged if we are responsible for the cause of the failure.

(2) This limited warranty applies only when the condition, method, environment, etc. of use are in compliance with the terms and conditions and instructions that are set forth in the instruction manual and user manual for the Product and the caution label affixed to the Product.

(3) Even during the term of warranty, the repair cost will be charged on you in the following cases;

1. a failure caused by your improper storing or handling, carelessness or negligence, etc., and a failure caused by your hardware or software problem
2. a failure caused by any alteration, etc. to the Product made on your side without our approval
3. a failure which may be regarded as avoidable, if your equipment in which the Product is incorporated is equipped with a safety device required by applicable laws and has any function or structure considered to be indispensable according to a common sense in the industry
4. a failure which may be regarded as avoidable if consumable parts designated in the instruction manual, etc. are duly maintained and replaced
5. any replacement of consumable parts (battery, fan, smoothing capacitor, etc.)
6. a failure caused by external factors such as inevitable accidents, including without limitation fire and abnormal fluctuation of voltage, and acts of God, including without limitation earthquake, lightning and natural disasters
7. a failure generated by an unforeseeable cause with a scientific technology that was not available at the time of the shipment of the Product from our company
8. any other failures which we are not responsible for or which you acknowledge we are not responsible for

2. Term of warranty after the stop of production

(1) We may accept the repair at charge for another seven (7) years after the production of the product is discontinued. The announcement of the stop of production for each model can be seen in our Sales and Service, etc.

(2) Please note that the Product (including its spare parts) cannot be ordered after its stop of production.

3. Service in overseas countries

Our regional FA Center in overseas countries will accept the repair work of the Product. However, the terms and conditions of the repair work may differ depending on each FA Center. Please ask your local FA center for details.

4. Exclusion of loss in opportunity and secondary loss from warranty liability

Regardless of the gratis warranty term, Mitsubishi shall not be liable for compensation to:

- (1) Damages caused by any cause found not to be the responsibility of Mitsubishi.
- (2) Loss in opportunity, lost profits incurred to the user by Failures of Mitsubishi products.
- (3) Special damages and secondary damages whether foreseeable or not, compensation for accidents, and compensation for damages to products other than Mitsubishi products.
- (4) Replacement by the user, maintenance of on-site equipment, start-up test run and other tasks.

5. Change of Product specifications

Specifications listed in our catalogs, manuals or technical documents may be changed without notice.

6. Application and use of the Product

- (1) For the use of our AC Servo, its applications should be those that may not result in a serious damage even if any failure or malfunction occurs in AC Servo, and a backup or fail-safe function should operate on an external system to AC Servo when any failure or malfunction occurs.
- (2) Our AC Servo is designed and manufactured as a general purpose product for use at general industries. Therefore, applications substantially influential on the public interest for such as atomic power plants and other power plants of electric power companies, and also which require a special quality assurance system, including applications for railway companies and government or public offices are not recommended, and we assume no responsibility for any failure caused by these applications when used.
In addition, applications which may be substantially influential to human lives or properties for such as airlines, medical treatments, railway service, incineration and fuel systems, man-operated material handling equipment, entertainment machines, safety machines, etc. are not recommended, and we assume no responsibility for any failure caused by these applications when used. We will review the acceptability of the abovementioned applications, if you agree not to require a specific quality for a specific application. Please contact us for consultation.

TRADEMARKS

MELSERVO is a trademark or registered trademark of Mitsubishi Electric Corporation in Japan and/or other countries. All other product names and company names are trademarks or registered trademarks of their respective companies.

IB(NA)-0300548ENG-A(2106)MEE

MODEL:

MODEL CODE:

mitsubishi electric corporation

HEAD OFFICE : TOKYO BUILDING, 2-7-3 MARUNOUCHI, CHIYODA-KU, TOKYO 100-8310, JAPAN
NAGOYA WORKS : 1-14, YADA-MINAMI 5-CHOME, HIGASHI-KU, NAGOYA, JAPAN

When exported from Japan, this manual does not require application to the
Ministry of Economy, Trade and Industry for service transaction permission.

Specifications are subject to change without notice.