



General-Purpose AC Servo

MITSUBISHI SERVO AMPLIFIERS & MOTORS
MELSERVO-J4

General-Purpose Interface AC Servo
MODEL

MR-J4- _A_ -RJ

MR-J4-03A6-RJ

SERVO AMPLIFIER
INSTRUCTION MANUAL
(POSITIONING MODE)

● Safety Instructions ●

Please read the instructions carefully before using the equipment.

To use the equipment correctly, do not attempt to install, operate, maintain, or inspect the equipment until you have read through this Instruction Manual, Installation guide, and appended documents carefully. Do not use the equipment until you have a full knowledge of the equipment, safety information and instructions. In this Instruction Manual, the safety instruction levels are classified into "WARNING" and "CAUTION".



Indicates that incorrect handling may cause hazardous conditions, resulting in death or severe injury.



Indicates that incorrect handling may cause hazardous conditions, resulting in medium or slight injury to personnel or may cause physical damage.

Note that the CAUTION level may lead to a serious consequence according to conditions. Please follow the instructions of both levels because they are important to personnel safety. What must not be done and what must be done are indicated by the following diagrammatic symbols.



Indicates what must not be done. For example, "No Fire" is indicated by .



Indicates what must be done. For example, grounding is indicated by .

In this Instruction Manual, instructions at a lower level than the above, instructions for other functions, and so on are classified into "POINT".

After reading this Instruction Manual, keep it accessible to the operator.

1. To prevent electric shock, note the following

WARNING

- Before wiring or inspection, turn off the power and wait for 15 minutes or more until the charge lamp turns off. Then, confirm that the voltage between P+ and N- is safe with a voltage tester and others. Otherwise, an electric shock may occur. In addition, when confirming whether the charge lamp is off or not, always confirm it from the front of the servo amplifier.
- Ground the servo amplifier and servo motor securely.
- Any person who is involved in wiring and inspection should be fully competent to do the work.
- Do not attempt to wire the servo amplifier and servo motor until they have been installed. Otherwise, it may cause an electric shock.
- Do not operate switches with wet hands. Otherwise, it may cause an electric shock.
- The cables should not be damaged, stressed, loaded, or pinched. Otherwise, it may cause an electric shock.
- During power-on or operation, do not open the front cover of the servo amplifier. Otherwise, it may cause an electric shock.
- Do not operate the servo amplifier with the front cover removed. High-voltage terminals and charging area are exposed and you may get an electric shock.
- Except for wiring and periodic inspection, do not remove the front cover of the servo amplifier even if the power is off. The servo amplifier is charged and you may get an electric shock.
- To prevent an electric shock, always connect the protective earth (PE) terminal (marked \oplus) of the servo amplifier to the protective earth (PE) of the cabinet.
- To avoid an electric shock, insulate the connections of the power supply terminals.

2. To prevent fire, note the following

CAUTION

- Install the servo amplifier, servo motor, and regenerative resistor on incombustible material. Installing them directly or close to combustibles will lead to a fire or smoke generation.
- Always connect a magnetic contactor between the power supply and the main circuit power supply (L1/L2/L3) of the servo amplifier, in order to configure a circuit that shuts down the power supply on the side of the servo amplifier's power supply. If a magnetic contactor is not connected, continuous flow of a large current may cause smoke or a fire when the servo amplifier malfunctions.
- In order to configure a circuit that shuts down the power supply on the side of the servo amplifier's power supply, always connect one molded-case circuit breaker or fuse per one servo amplifier between the power supply and the main circuit power supply (L1/L2/L3) of a servo amplifier. If a molded-case circuit breaker or fuse is not connected, continuous flow of a large current may cause smoke or a fire when the servo amplifier malfunctions.
- When using the regenerative resistor, switch power off with the alarm signal. Otherwise, a regenerative transistor malfunction or the like may overheat the regenerative resistor, causing smoke or a fire.
- Provide adequate protection to prevent screws and other conductive matter, oil and other combustible matter from entering the servo amplifier and servo motor.

3. To prevent injury, note the following

CAUTION

- Only the voltage specified in the Instruction Manual should be applied to each terminal. Otherwise, a burst, damage, etc. may occur.
- Connect cables to the correct terminals. Otherwise, a burst, damage, etc. may occur.
- Ensure that polarity (+/-) is correct. Otherwise, a burst, damage, etc. may occur.
- The servo amplifier heat sink, regenerative resistor, servo motor, etc., may be hot while the power is on and for some time after power-off. Take safety measures such as providing covers to avoid accidentally touching them by hands and parts such as cables.

4. Additional instructions

The following instructions should also be fully noted. Incorrect handling may cause a malfunction, injury, electric shock, fire, etc.

(1) Transportation and installation

CAUTION

- Transport the products correctly according to their mass.
- Stacking in excess of the specified number of product packages is not allowed.
- Do not hold the front cover when transporting the servo amplifier. Otherwise, it may drop.
- Install the servo amplifier and the servo motor in a load-bearing place in accordance with the Instruction Manual.
- Do not get on or put heavy load on the equipment.
- The equipment must be installed in the specified direction.
- Leave specified clearances between the servo amplifier and the cabinet walls or other equipment.
- Do not install or operate the servo amplifier and servo motor which have been damaged or have any parts missing.
- Do not block the intake and exhaust areas of the servo amplifier. Otherwise, it may cause a malfunction.
- Do not drop or strike the servo amplifier and servo motor. Isolate them from all impact loads.
- When you keep or use the equipment, please fulfill the following environment.

Item		Environment
Ambient temperature	Operation	0 °C to 55 °C (non-freezing)
	Storage	-20 °C to 65 °C (non-freezing)
Ambient humidity	Operation	5 %RH to 90 %RH (non-condensing)
	Storage	
Ambience		Indoors (no direct sunlight), free from corrosive gas, flammable gas, oil mist, dust, and dirt
Altitude		2000 m or less above sea level (Contact your local sales office for the altitude for options.)
Vibration resistance		5.9 m/s ² , at 10 Hz to 55 Hz (directions of X, Y and Z axes)

- When the product has been stored for an extended period of time, contact your local sales office.
- When handling the servo amplifier, be careful about the edged parts such as corners of the servo amplifier.
- The servo amplifier must be installed in a metal cabinet.

⚠ CAUTION

- When fumigants that contain halogen materials such as fluorine, chlorine, bromine, and iodine are used for disinfecting and protecting wooden packaging from insects, they cause malfunction when entering our products. Please take necessary precautions to ensure that remaining materials from fumigant do not enter our products, or treat packaging with methods other than fumigation (heat method). Additionally, disinfect and protect wood from insects before packing products.

(2) Wiring

⚠ CAUTION

- Wire the equipment correctly and securely. Otherwise, the servo motor may operate unexpectedly.
- Do not install a power capacitor, surge killer, or radio noise filter (optional FR-BIF(-H)) on the servo amplifier output side.
- To avoid a malfunction, connect the wires to the correct phase terminals (U/V/W) of the servo amplifier and servo motor.
- Connect the servo amplifier power output (U/V/W) to the servo motor power input (U/V/W) directly. Do not let a magnetic contactor, etc. intervene. Otherwise, it may cause a malfunction.

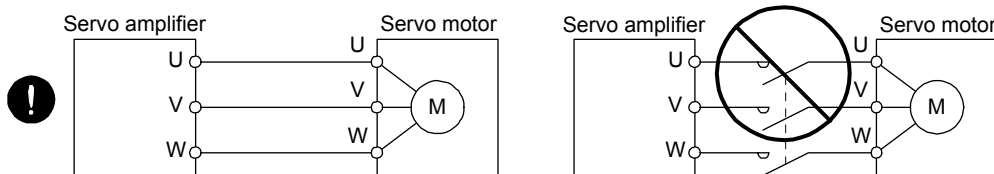

- The connection diagrams in this instruction manual are shown for sink interfaces, unless stated otherwise.
- The surge absorbing diode installed to the DC relay for control output should be fitted in the specified direction. Otherwise, the emergency stop and other protective circuits may not operate.

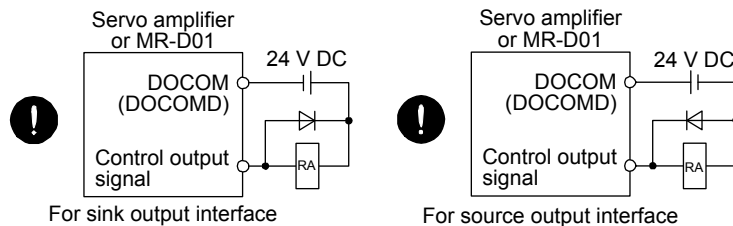

- When the cable is not tightened enough to the terminal block, the cable or terminal block may generate heat because of the poor contact. Be sure to tighten the cable with specified torque.
- Connecting a servo motor of the wrong axis to U, V, W, or CN2 of the servo amplifier may cause a malfunction.
- Configure a circuit to turn off EM2 or EM1 when the main circuit power is turned off to prevent an unexpected restart of the servo amplifier.

(3) Test run and adjustment

⚠ CAUTION

- Before operation, check the parameter settings. Improper settings may cause some machines to operate unexpectedly.
- Never make a drastic adjustment or change to the parameter values as doing so will make the operation unstable.
- Do not get close to moving parts during the servo-on status.

(4) Usage

⚠ CAUTION

- When it is assumed that a hazardous condition may occur due to a power failure or product malfunction, use a servo motor with an external brake to prevent the condition.
- Do not disassemble, repair, or modify the equipment.
- Before resetting an alarm, make sure that the run signal of the servo amplifier is off in order to prevent a sudden restart. Otherwise, it may cause an accident.
- Use a noise filter, etc. to minimize the influence of electromagnetic interference. Electromagnetic interference may be given to the electronic equipment used near the servo amplifier.
- Burning or breaking a servo amplifier may cause a toxic gas. Do not burn or break it.
- Use the servo amplifier with the specified servo motor.
- The electromagnetic brake on the servo motor is designed to hold the motor shaft and should not be used for ordinary braking.
- For such reasons as service life and mechanical structure (e.g. where a ball screw and the servo motor are coupled via a timing belt), the electromagnetic brake may not hold the motor shaft. To ensure safety, install a stopper on the machine side.

(5) Corrective actions

⚠ CAUTION

- Ensure safety by confirming the power off, etc. before performing corrective actions. Otherwise, it may cause an accident.
- When it is assumed that a hazardous condition may occur due to a power failure or product malfunction, use a servo motor with an electromagnetic brake or external brake to prevent the condition.
- Configure an electromagnetic brake circuit which is interlocked with an external emergency stop switch.

Contacts must be opened when ALM (Malfunction) or MBR (Electromagnetic brake interlock) turns off.

Contacts must be opened with the emergency stop switch.

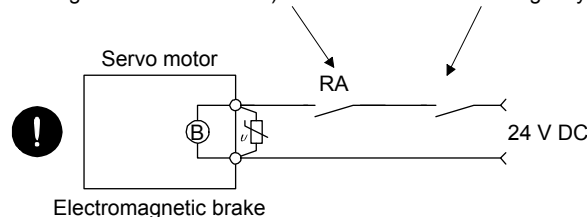

- When any alarm has occurred, eliminate its cause, ensure safety, and deactivate the alarm before restarting operation.
- Provide an adequate protection to prevent unexpected restart after an instantaneous power failure.

(6) Maintenance, inspection and parts replacement

CAUTION

- Make sure that the emergency stop circuit operates properly such that an operation can be stopped immediately and a power is shut off by the emergency stop switch.
- It is recommended that the servo amplifier be replaced every 10 years when it is used in general environment.
- When using the servo amplifier that has not been energized for an extended period of time, contact your local sales office.

(7) General instruction

- To illustrate details, the equipment in the diagrams of this Instruction Manual may have been drawn without covers and safety guards. When the equipment is operated, the covers and safety guards must be installed as specified. Operation must be performed in accordance with this Instruction Manual.

● DISPOSAL OF WASTE ●

Please dispose a servo amplifier, battery (primary battery) and other options according to your local laws and regulations.

EEPROM life

The number of write times to the EEPROM, which stores parameter settings, etc., is limited to 100,000. If the total number of the following operations exceeds 100,000, the servo amplifier may malfunction when the EEPROM reaches the end of its useful life.

- Write to the EEPROM due to parameter setting changes
- Write to the EEPROM due to device changes
- Write to the EEPROM due to point table changes
- Write to the EEPROM due to program changes

STO function of the servo amplifier

When using the STO function of the servo amplifier, refer to chapter 13 of "MR-J4-_A_(-RJ) Servo Amplifier Instruction Manual".

For the MR-J3-D05 safety logic unit, refer to app. 5 of "MR-J4-_A_(-RJ) Servo Amplifier Instruction Manual".

Compliance with global standards

For the compliance with global standards, refer to app. 4 of "MR-J4-_A_(-RJ) Servo Amplifier Instruction Manual".

«About the manual»

You must have this Instruction Manual and the following manuals to use this servo. Ensure to prepare them to use the servo safely.

Relevant manuals

Manual name	Manual No.
MELSERVO MR-J4-_A_(-RJ) Servo Amplifier Instruction Manual	SH(NA)030107ENG
MELSERVO MR-J4-_A_-RJ Servo Amplifier Instruction Manual (Modbus-RTU Protocol) (Note 5)	SH(NA)030175ENG
MELSERVO MR-J4-DU_(-RJ)/MR-CR55K_ Instruction Manual (Note 6)	SH(NA)030153ENG
MELSERVO-J4 Servo Amplifier Instruction Manual (Troubleshooting)	SH(NA)030109ENG
MELSERVO Servo Motor Instruction Manual (Vol. 3) (Note 1)	SH(NA)030113ENG
MELSERVO Linear Servo Motor Instruction Manual (Note 2)	SH(NA)030110ENG
MELSERVO Direct Drive Motor Instruction Manual (Note 3)	SH(NA)030112ENG
MELSERVO Linear Encoder Instruction Manual (Note 2, 4)	SH(NA)030111ENG
EMC Installation Guidelines	IB(NA)67310ENG
Parameter Unit MR-PRU03 Instruction Manual (MR-J4)	SH(NA)030186ENG

- Note
1. It is necessary for using a rotary servo motor.
 2. It is necessary for using a linear servo motor.
 3. It is necessary for using a direct drive motor.
 4. It is necessary for using a fully closed loop system.
 5. It is necessary for using the Modbus-RTU communication function.
 6. It is necessary for using the MR-J4-DU-_A_(-RJ) drive unit or MR-CR55K_ converter unit.

This Instruction Manual does not describe the following items. The followings are the same as MR-J4-_A_-RJ Servo amplifiers. For details of the items, refer to each chapter/section of the detailed explanation field. "MR-J4-_A_" means "MR-J4-_A_(-RJ) Servo Amplifier Instruction Manual".

Item	Detailed explanation
Installation	MR-J4-_A_ chapter 2
Normal gain adjustment	MR-J4-_A_ chapter 6
Special adjustment functions	MR-J4-_A_ chapter 7
Dimensions	MR-J4-_A_ chapter 9
Characteristics	MR-J4-_A_ chapter 10
ABSOLUTE POSITION DETECTION SYSTEM (only 12.1 Summary and 12.2 Battery)	MR-J4-_A_ chapter 12
USING STO FUNCTION	MR-J4-_A_ chapter 13
USING A LINEAR SERVO MOTOR (Note)	MR-J4-_A_ chapter 15
USING A DIRECT DRIVE MOTOR	MR-J4-_A_ chapter 16
FULLY CLOSED LOOP SYSTEM (Note)	MR-J4-_A_ chapter 17
MR-J4-03A6-RJ SERVO AMPLIFIER	MR-J4-_A_ chapter 18

Note. For the home position return, refer to each chapter indicated in the detailed explanation field and chapter 4 in this Instruction Manual.

«Wiring»

Wires mentioned in this Instruction Manual are selected based on the ambient temperature of 40 °C.

«U.S. customary units»

U.S. customary units are not shown in this manual. Convert the values if necessary according to the following table.

Quantity	SI (metric) unit	U.S. customary unit
Mass	1 [kg]	2.2046 [lb]
Length	1 [mm]	0.03937 [inch]
Torque	1 [N·m]	141.6 [oz·inch]
Moment of inertia	1 [(× 10 ⁻⁴ kg·m ²)]	5.4675 [oz·inch ²]
Load (thrust load/axial load)	1 [N]	0.2248 [lbf]
Temperature	N [°C] × 9/5 + 32	N [°F]

CONTENTS

1. FUNCTIONS AND CONFIGURATION	1- 1 to 1-12
1.1 For proper use of the positioning mode.....	1- 1
1.2 Positioning mode specification list.....	1- 2
1.3 Function list.....	1- 5
1.4 Configuration including peripheral equipment.....	1-10
2. SIGNALS AND WIRING	2- 1 to 2-46
2.1 I/O signal connection example.....	2- 3
2.1.1 MR-J4-_A_-RJ 100 W or more	2- 3
2.1.2 MR-J4-03A6-RJ	2- 9
2.2 Connectors and pin assignment	2-15
2.3 Signal (device) explanations.....	2-22
2.4 Analog override.....	2-38
2.5 Internal connection diagram	2-40
2.6 Power-on sequence.....	2-45
2.6.1 MR-J4-_A_-RJ 100 W or more	2-45
2.6.2 MR-J4-03A6-RJ	2-46
3. DISPLAY AND OPERATION SECTIONS	3- 1 to 3-54
3.1 MR-J4-_A_-RJ 100 W or more	3- 1
3.1.1 Display sequence.....	3- 1
3.1.2 Status display	3- 3
3.1.3 Diagnostic mode	3-12
3.1.4 Alarm mode	3-15
3.1.5 Point table setting.....	3-17
3.1.6 Parameter mode	3-21
3.1.7 External I/O signal display.....	3-23
3.1.8 Output signal (DO) forced output.....	3-24
3.1.9 Single-Step feed.....	3-25
3.1.10 Teaching function.....	3-27
3.2 MR-J4-03A6-RJ	3-28
3.2.1 Display flowchart	3-28
3.2.2 Status display mode.....	3-29
3.2.3 Diagnostic mode	3-34
3.2.4 Alarm mode	3-38
3.2.5 Point table setting.....	3-40
3.2.6 Parameter mode	3-44
3.2.7 External I/O signal display.....	3-49
3.2.8 Output signal (DO) forced output.....	3-50
3.2.9 Step feed.....	3-51
3.2.10 Teaching function.....	3-53
4. HOW TO USE THE POINT TABLE	4- 1 to 4-80
4.1 Startup	4- 2
4.1.1 Power on and off procedures.....	4- 2

4.1.2	Stop	4- 2
4.1.3	Test operation	4- 3
4.1.4	Parameter setting	4- 4
4.1.5	Point table setting	4- 5
4.1.6	Actual operation	4- 5
4.1.7	Troubleshooting at start-up	4- 5
4.2	Automatic operation mode	4- 7
4.2.1	Automatic operation mode	4- 7
4.2.2	Automatic operation using point table	4-12
4.3	Manual operation mode	4-42
4.3.1	JOG operation	4-42
4.3.2	Manual pulse generator operation	4-44
4.4	Home position return mode	4-46
4.4.1	Outline of home position return	4-46
4.4.2	Dog type home position return	4-49
4.4.3	Count type home position return	4-51
4.4.4	Data set type home position return	4-53
4.4.5	Stopper type home position return	4-54
4.4.6	Home position ignorance (servo-on position as home position)	4-56
4.4.7	Dog type rear end reference home position return	4-57
4.4.8	Count type front end reference home position return	4-59
4.4.9	Dog cradle type home position return	4-60
4.4.10	Dog type last Z-phase reference home position return	4-62
4.4.11	Dog type front end reference home position return type	4-64
4.4.12	Dogless Z-phase reference home position return type	4-66
4.4.13	Automatic retract function used for the home position return	4-67
4.4.14	Automatic positioning to home position function	4-68
4.4.15	Precautions for using linear servo motors	4-69
4.4.16	Precautions for using the fully closed loop system	4-73
4.5	Roll feed mode using the roll feed display function	4-76
4.6	Point table setting method	4-78
4.6.1	Setting procedure	4-78
4.6.2	Detailed setting window	4-80

5. HOW TO USE THE PROGRAM	5- 1 to 5-68
----------------------------------	---------------------

5.1	Startup	5- 1
5.1.1	Power on and off procedures	5- 1
5.1.2	Stop	5- 2
5.1.3	Test operation	5- 3
5.1.4	Parameter setting	5- 4
5.1.5	Actual operation	5- 5
5.1.6	Troubleshooting at start-up	5- 5
5.2	Program operation method	5- 6
5.2.1	Program operation method	5- 6
5.2.2	Program language	5- 7
5.2.3	Basic settings of signals and parameters	5-30
5.2.4	Timing chart of the program operation	5-32
5.3	Manual operation mode	5-34
5.3.1	JOG operation	5-34
5.3.2	Manual pulse generator operation	5-35

5.4 Home position return mode	5-37
5.4.1 Summary of home position return	5-37
5.4.2 Dog type home position return	5-40
5.4.3 Count type home position return	5-42
5.4.4 Data set type home position return	5-44
5.4.5 Stopper type home position return	5-45
5.4.6 Home position ignorance (servo-on position as home position)	5-46
5.4.7 Dog type rear end reference home position return	5-47
5.4.8 Count type front end reference home position return	5-49
5.4.9 Dog cradle type home position return	5-51
5.4.10 Dog type last Z-phase reference home position return	5-53
5.4.11 Dog type front end reference home position return type	5-55
5.4.12 Dogless Z-phase reference home position return type	5-57
5.4.13 Automatic retract function used for the home position return	5-58
5.5 Serial communication operation	5-59
5.5.1 Positioning operation using the program	5-59
5.5.2 Multi-drop method (RS-422 communication)	5-60
5.5.3 Group specification	5-61
5.6 Incremental value command method	5-63
5.7 Roll feed mode using the roll feed display function	5-64
5.8 Program setting method	5-65
5.8.1 Setting procedure	5-65
5.8.2 Window for program edit	5-66
5.8.3 Indirect addressing window	5-67

6. HOW TO USE INDEXER	6- 1 to 6-30
------------------------------	---------------------

6.1 Startup	6- 2
6.1.1 Power on and off procedures	6- 2
6.1.2 Stop	6- 2
6.1.3 Test operation	6- 3
6.1.4 Parameter setting	6- 4
6.1.5 Actual operation	6- 5
6.1.6 Troubleshooting at start-up	6- 5
6.2 Automatic operation mode	6- 7
6.2.1 Automatic operation mode	6- 7
6.2.2 Automatic operation mode 1 (rotation direction specifying indexer)	6- 8
6.2.3 Automatic operation mode 2 (shortest rotating indexer)	6-12
6.3 Manual operation mode	6-15
6.3.1 Station JOG operation	6-15
6.3.2 JOG operation	6-18
6.4 Home position return mode	6-20
6.4.1 Outline of home position return	6-20
6.4.2 Torque limit changing dog type home position return	6-22
6.4.3 Torque limit changing data set type	6-24
6.4.4 Backlash compensation and digital override	6-26
6.4.5 Safety precautions	6-29

7. PARAMETERS	7- 1 to 7-100
----------------------	----------------------

7.1 Parameter list	7- 2
--------------------------	------

7.1.1	Basic setting parameters ([Pr. PA__])	7- 3
7.1.2	Gain/filter setting parameters ([Pr. PB__])	7- 4
7.1.3	Extension setting parameters ([Pr. PC__])	7- 6
7.1.4	I/O setting parameters ([Pr. PD__])	7- 9
7.1.5	Extension setting 2 parameters ([Pr. PE__])	7-10
7.1.6	Extension setting 3 parameters ([Pr. PF__])	7-12
7.1.7	Linear servo motor/DD motor setting parameters ([Pr. PL__])	7-13
7.1.8	Option setting parameters ([Pr. Po__])	7-14
7.1.9	Positioning control parameters ([Pr. PT__])	7-15
7.2	Detailed list of parameters	7-16
7.2.1	Basic setting parameters ([Pr. PA__])	7-17
7.2.2	Gain/filter setting parameters ([Pr. PB__])	7-30
7.2.3	Extension setting parameters ([Pr. PC__])	7-42
7.2.4	I/O setting parameters ([Pr. PD__])	7-56
7.2.5	Extension setting 2 parameters ([Pr. PE__])	7-68
7.2.6	Extension setting 3 parameters ([Pr. PF__])	7-71
7.2.7	Linear servo motor/DD motor setting parameters ([Pr. PL__])	7-73
7.2.8	Option setting parameters ([Pr. Po__])	7-75
7.2.9	Positioning control parameters ([Pr. PT__])	7-83
7.3	How to set the electronic gear	7-93
7.3.1	Electronic gear settings in the point table method and program method	7-93
7.3.2	Electronic gear setting in the indexer method	7-96
7.4	Software limit	7-97
7.5	Stop method for LSP (Forward rotation stroke end) off or LSN (Reverse rotation stroke end) off	7-98
7.6	Stop method at software limit detection	7-99

8. TROUBLESHOOTING	8- 1 to 8-14
---------------------------	---------------------

8.1	Explanation for the lists	8- 1
8.2	Alarm list	8- 2
8.3	Warning list	8-11

9. OPTIONS AND PERIPHERAL EQUIPMENT	9- 1 to 9- 4
--	---------------------

9.1	MR-HDP01 manual pulse generator	9- 2
-----	---------------------------------	------

10. COMMUNICATION FUNCTION (MITSUBISHI GENERAL-PURPOSE AC SERVO PROTOCOL)	10- 1 to 10-40
--	-----------------------

10.1	Command and data No. list	10- 1
10.1.1	Reading command	10- 2
10.1.2	Writing commands	10-12
10.2	Detailed explanations of commands	10-16
10.2.1	External I/O signal status (DIO diagnosis)	10-16
10.2.2	Input device on/off	10-21
10.2.3	Input device on/off (for test operation)	10-22
10.2.4	Test operation mode	10-23
10.2.5	Output signal pin on/off (output signal (DO) forced output)	10-25
10.2.6	Point table	10-26
10.3	Settings equivalent to previous models	10-34
10.3.1	Relevant matters to monitor information	10-34
10.3.2	Relevant matters to input/output	10-36

11. MR-D01 EXTENSION I/O UNIT

11- 1 to 11-78

11.1	Function block diagram.....	11- 2
11.2	Structure	11- 4
11.2.1	Parts identification.....	11- 4
11.2.2	Installation and removal of the MR-D01 extension I/O unit	11- 5
11.3	Configuration including peripheral equipment.....	11- 9
11.4	Installation direction and clearances	11-11
11.5	Signals and wiring.....	11-13
11.5.1	I/O signal connection diagram	11-14
11.5.2	Connectors and pin assignment	11-40
11.5.3	Signal (device) explanations	11-42
11.5.4	Interfaces	11-56
11.6	Monitor display with MR Configurator2.....	11-60
11.7	Operation	11-62
11.7.1	Operation mode and selecting method	11-62
11.7.2	When using MR-DS60 (6-digit digital switch) for automatic operation with BCD (3-digit × 2) inputs	11-62
11.7.3	When using a programmable controller for automatic operation with BCD (3 digits × 2) inputs.....	11-66
11.7.4	Home position return in the BCD (3 digits × 2) input operation	11-69
11.8	Dimensions	11-70
11.8.1	MR-D01 extension I/O unit.....	11-70
11.8.2	When an MR-D01 extension IO unit is connected to a servo amplifier	11-70
11.9	Options and peripheral equipment	11-71
11.9.1	Combinations of cable/connector sets.....	11-71
11.9.2	MR-DS60 (6-digit digital switch).....	11-72
11.9.3	PS7DW-20V14B-F (Junction terminal block) (recommended).....	11-75
11.9.4	MR-TB50 (Junction terminal block).....	11-77

12. APPLICATION OF FUNCTIONS

12- 1 to 12-62

12.1	Simple cam function	12- 1
12.1.1	Outline of simple cam function.....	12- 1
12.1.2	Simple cam function block	12- 2
12.1.3	Simple cam specification list.....	12- 3
12.1.4	Control of simple cam function.....	12- 4
12.1.5	Operation in combination with the simple cam	12- 5
12.1.6	Setting list.....	12- 7
12.1.7	Data to be used with simple cam function	12- 8
12.1.8	Function block diagram for displaying state of simple cam control	12-28
12.1.9	Operation	12-28
12.1.10	Cam No. setting method	12-38
12.1.11	Stop operation of cam control	12-39
12.1.12	Restart operation of cam control.....	12-41
12.1.13	Cam axis position at cam control switching.....	12-42
12.1.14	Clutch	12-49
12.1.15	Cam position compensation target position.....	12-51
12.1.16	Cam position compensation time constant.....	12-52
12.2	Mark detection	12-53
12.2.1	Current position latch function	12-53

12.2.2 Interrupt positioning function.....	12-59
12.3 Infinite feed function (setting degree).....	12-62

1. FUNCTIONS AND CONFIGURATION

1. FUNCTIONS AND CONFIGURATION

The following items are the same as MR-J4-A-RJ servo amplifiers. For details, refer to each section indicated in the detailed explanation field. "MR-J4-A" means "MR-J4-A(-RJ) Servo Amplifier Instruction Manual".

Item	Detailed explanation	
	MR-J4- <u>A</u> -RJ 100 W or more	MR-J4-03A6-RJ
Combinations of servo amplifiers and servo motors	MR-J4- <u>A</u> section 1.4	MR-J4- <u>A</u> section 18.1.4
Model code definition	MR-J4- <u>A</u> section 1.6	MR-J4- <u>A</u> section 18.1.6
Structure (parts identification)	MR-J4- <u>A</u> section 1.7	MR-J4- <u>A</u> section 18.1.7

1.1 For proper use of the positioning mode

(1) Servo amplifier/MR Configurator2

The positioning mode is used by the servo amplifier and MR Configurator2 with the following software versions.

Product name	Model	Software version
Servo amplifier	MR-J4- <u>A</u> -RJ 100 W or more	B3 or later
	MR-J4-03A6-RJ	Does not depend on the software version.
MR Configurator2	SW1DNC-MRC2- <u> </u>	1.34L or later

(2) Parameter setting

(a) Selection of the positioning mode

Select a positioning mode with [Pr. PA01 Operation mode] to use.

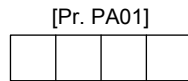

Control mode selection
 6: Positioning mode (point table method)
 7: Positioning mode (program method)
 8: Positioning mode (indexer method)

(b) Positioning control parameters ([Pr. PT_ _])

To enable read/write the positioning control parameters ([Pr. PT_ _]), set [Pr. PA19 Parameter writing inhibit] to "0 0 A B".

(c) Assigning recommended input/output devices

Assign recommended input/output devices to the pins of CN1 in accordance with each chapter of point table/program/indexer method.

1. FUNCTIONS AND CONFIGURATION

1.2 Positioning mode specification list

The specifications only of the positioning mode are listed here. For other specifications, refer to section 1.3 and 18.1.3 of "MR-J4-_A_(-RJ) Servo Amplifier Instruction Manual".

Item		Description			
Servo amplifier model		MR-J4-_A_-RJ 100 W or more/MR-J4-03A6-RJ			
Positioning mode	Command method	Point table	Operational specifications	Positioning with specification of point table No. (255 points) (Note 6, 7)	
			Position command input (Note 1)	Absolute value command method	Set in the point table. Setting range of feed length per point: -999999 to 999999 [$\times 10^{\text{STM}}$ μm], -99.9999 to 99.9999 [$\times 10^{\text{STM}}$ inch], -999999 to 999999 [pulse], Setting range of rotation angle: -360.000 to 360.000 [degree]
		Incremental value command method		Set in the point table. Setting range of feed length per point: 0 to 999999 [$\times 10^{\text{STM}}$ μm], 0 to 99.9999 [$\times 10^{\text{STM}}$ inch], 0 to 999999 [pulse], Setting range of rotation angle: 0 to 999.999 [degree]	
		Speed command input	Set the acceleration/deceleration time constants in the point table. Set the S-pattern acceleration/deceleration time constants with [Pr. PC03].		
		System	Signed absolute value command method/incremental value command method		
		Analog override	0 V DC to ± 10 V DC/0% to 200%		
		Torque limit	Set with parameter or external analog input (0 V DC to +10 V DC/maximum torque)		
		BCD input	Position command input (Note 1)	Absolute value command method	Signed 6-digit BCD digital switch or contact input Setting range of feed length: -999999 to 999999 [$\times 10^{\text{STM}}$ μm], -99.9999 to 99.9999 [$\times 10^{\text{STM}}$ inch], -999999 to 999999 [pulse], Setting range of rotation angle: -360.000 to 360.000 [degree]
				Incremental value command method	Signed 6-digit BCD digital switch or contact input Setting range of feed length: 0 to 999999 [$\times 10^{\text{STM}}$ μm], 0 to 99.9999 [$\times 10^{\text{STM}}$ inch], 0 to 999999 [pulse], Setting range of rotation angle: 0 to 999.999 [degree]
			Speed command input	Selects the rotation speeds and acceleration/deceleration times of the point table No. 1 to 15 by a contact input. Set the S-pattern acceleration/deceleration time constants with [Pr. PC03].	
	System		Signed absolute value command method/incremental value command method		
	Position command data input	RS-422/RS-485 communication (Note 5)	Position command input (Note 1)	Setting of position command data with RS-422/RS-485 communication Setting range of feed length per point: -999999 to 999999 [$\times 10^{\text{STM}}$ μm], -99.9999 to 99.9999 [$\times 10^{\text{STM}}$ inch], -999999 to 999999 [pulse], Setting range of rotation angle: -360.000 to 360.000 [degree]	
			Incremental value command method	Setting of position command data with RS-422/RS-485 communication Setting range of feed length per point: 0 to 999999 [$\times 10^{\text{STM}}$ μm], 0 to 99.9999 [$\times 10^{\text{STM}}$ inch], 0 to 999999 [pulse], Setting range of rotation angle: 0 to 999.999 [degree]	
		Speed command input	Selects the rotation speed and acceleration/deceleration time constant through RS-422/RS-485 communication. Set the S-pattern acceleration/deceleration time constants with [Pr. PC03].		
		System	Signed absolute value command method/incremental value command method		
	Program	Operational specifications		Program language (program with MR Configurator2) Program capacity: 640 steps (256 programs)	
		Position command input (Note 1)	Absolute value command method	Set with program language. Setting range of feed length: -999999 to 999999 [$\times 10^{\text{STM}}$ μm], -99.9999 to 99.9999 [$\times 10^{\text{STM}}$ inch], -999999 to 999999 [pulse], Setting range of rotation angle: -360.000 to 360.000 [degree]	
			Incremental value command method	Set with program language. Setting range of feed length: -999999 to 999999 [$\times 10^{\text{STM}}$ μm], -99.9999 to 99.9999 [$\times 10^{\text{STM}}$ inch], -999999 to 999999 [pulse], Setting range of rotation angle: -999.999 to 999.999 [degree]	
		Speed command input	Set servo motor speed, acceleration/deceleration time constants, and S-pattern acceleration/deceleration time constants with program language. S-pattern acceleration/deceleration time constants are also settable with [Pr. PC03].		
		System	Signed absolute value command method/signed incremental value command method		
Analog override		Set with external analog input (0 V DC to ± 10 V DC/0% to 200%)			
Torque limit		Set with parameter or external analog input (0 V DC to +10 V DC/maximum torque)			

1. FUNCTIONS AND CONFIGURATION

		Item	Description		
Positioning mode	Command method	Indexer	Operational specifications	Positioning by specifying the station position (Note 7) The maximum number of divisions: 255	
			Speed command input	Selects the rotation speed and acceleration/deceleration time constant by a contact input.	
			System	Rotation direction specifying indexer/shortest rotating indexer	
			Digital override	Selects the override multiplying factor by a contact input.	
			Torque limit	Set with parameter or external analog input (0 V DC to +10 V DC/maximum torque)	
	Operation mode	Automatic operation mode	Point table	Each positioning operation	Point table No. input method/position data input method Operates each positioning based on position command and speed command.
				Automatic continuous positioning operation	Varying-speed operation (2 to 255 speeds)/automatic continuous positioning operation (2 to 255 points)/ automatic continuous operation to a point table selected at startup/ automatic continuous operation to the point table No. 1
			Program		Depends on settings of program language.
			Indexer	Rotation direction specifying indexer	Positions to the specified station. Rotation direction settable
				Shortest rotating indexer	Positions to the specified station. Rotates in the shorter direction from the current position.
		Manual operation mode	Point table/ program	JOG operation	Executes a contact input or an inching operation with the RS-422/RS-485 communication function based on speed command set with parameters.
				Manual pulse generator operation	Manual feeding is executed with a manual pulse generator. Command pulse multiplication: select from ×1, ×10, and ×100 with a parameter.
			Indexer	JOG operation	Decelerates to a stop regardless of the station.
				Station JOG operation	Rotates in a direction specified by the rotation direction decision when the start signal turns on.
					Positions to the nearest station where the servo motor can decelerate to a stop when the start signal turns off.
	Home position return mode	Point table/program	Dog type	Returns to home position upon Z-phase pulse after passing through the proximity dog. home position address settable/home position shift amount settable/home position return direction selectable/ automatic retract on dog back to home position/automatic stroke retract function	
			Count type	Returns to home position upon the encoder pulse count after touching the proximity dog. Home position return direction selectable/home position shift amount settable/home position address settable/ automatic retract on dog back to home position/automatic stroke retract function	
			Data set type	Returns to home position without dog. Sets any position as a home position using manual operation, etc./home position address settable	
			Stopper type	Returns to home position upon hitting the stroke end. Home position return direction selectable/home position address settable	
			Home position ignorance (servo-on position as home position)	Sets a home position where SON (Servo-on) signal turns on. Home position address settable	
Dog type rear end reference			Returns to home position based on the rear end of the proximity dog. Home position return direction selectable/home position shift amount settable/home position address settable/ automatic retract on dog back to home position/automatic stroke retract function		
Count type front end reference			Returns to home position based on the front end of the proximity dog. Home position return direction selectable/home position shift amount settable/home position address settable/ automatic retract on dog back to home position/automatic stroke retract function		
Dog cradle type			Returns to home position upon the first Z-phase pulse based on the front end of the proximity dog. Home position return direction selectable/home position shift amount settable/home position address settable/ automatic retract on dog back to home position/automatic stroke retract function		
Dog type last Z-phase reference (Note 4)			Returns to home position upon the Z-phase pulse right before the proximity dog based on the front end of the proximity dog. Home position return direction selectable/home position shift amount settable/home position address settable/ automatic retract on dog back to home position/automatic stroke retract function		
Dog type front end reference			Returns to home position to the front end of the dog based on the front end of the proximity dog. Home position return direction selectable/home position shift amount settable/home position address settable/ automatic retract on dog back to home position/automatic stroke retract function		
Dogless Z-phase reference (Note 4)			Returns to home position to the Z-phase pulse with respect to the first Z-phase pulse. Home position return direction selectable/home position shift amount settable/home position address settable		
Indexer			Torque limit changing dog type	Returns to home position upon Z-phase pulse after an external limit is detected. Home position return direction selectable/home position shift amount settable/home position address settable Torque limit automatic changing function	
			Torque limit changing data set type	Returns to home position without external limits. Sets any position as home position/home position address settable/torque limit automatic changing function	
Automatic positioning to home position function (Note 2)			High-speed automatic positioning to a defined home position		
Other functions		Absolute position detection/backlash compensation/overtravel prevention with external limit switch (LSP/LSN)/software stroke limit/mark detection function (Note 3)/override			

1. FUNCTIONS AND CONFIGURATION

- Note
1. STM is the ratio to the setting value of the position data. STM can be changed with [Pr. PT03 Feeding function selection].
 2. The automatic positioning to home position function is not available with the program method and the indexer method.
 3. Indexer method does not have the mark detection function.
 4. Dog type last Z-phase reference home position return and dogless Z-phase reference home position return type are not compatible with direct drive motors and incremental linear encoders.
 5. For MR-J4-_A_-RJ servo amplifiers with a capacity of 100 W or more, the RS-485 communication is available with the servo amplifiers manufactured in November, 2014 or later.
 6. For MR-J4-03A6-RJ servo amplifiers, point table No. 1 to No. 99 can be set with the operation section (4 push buttons). Use MR Configurator2 to set point table No. 100 to 255. (Refer to section 3.2.5.)
 7. For MR-J4-03A6-RJ servo amplifiers, up to six points of DO are available; therefore, PT0 (Point table No. output 1) to PT7 (Point table No. output 8) or PS0 (Station output 1) to PS7 (Station output 8) cannot be outputted simultaneously.

1. FUNCTIONS AND CONFIGURATION

1.3 Function list

POINT
<ul style="list-style-type: none"> ● The symbols in the control mode column mean as follows. CP: Positioning mode (point table method) CL: Positioning mode (program method) PS: Positioning mode (indexer method)

The following table lists the functions of this servo. For details of the functions, refer to each section indicated in the detailed explanation field. "MR-J4-_A_" means "MR-J4-_A_(-RJ) Servo Amplifier Instruction Manual".

Function	Description	Control mode			Detailed explanation
		CP/BCD	CL	PS	
Model adaptive control	This function achieves a high response and stable control following the ideal model. The two-degrees-of-freedom model adaptive control enables you to set a response to the command and response to the disturbance separately. Additionally, this function can be disabled. To disable this function, refer to section 7.5 of "MR-J4-_A_(-RJ) Servo Amplifier Instruction Manual". This is available with servo amplifiers with software version B4 or later. Check the software version using MR Configurator2.	○	○	○	/
Positioning mode (point table method)	Set 1 to 255 point tables in advance, and select any point table to perform operation in accordance with the set values. To select point tables, use external input signals or communication function.	○	/	/	Chapter 4
Positioning mode (program method)	Set 1 to 256 programs in advance and select any program to perform operation in accordance with the programs. To select programs, use external input signals or communication function.	/	○	/	Chapter 5
Positioning mode (indexer method)	Set 2 to 255 divided stations in advance to perform operation to the station positions. To select station positions, use external input signals or communication function.	/	/	○	Chapter 6
Roll feed display function	Positions based on specified travel distance from a status display "0" of current/command positions at start.	○	○	/	Section 4.5
Mark detection	Current position latch function	○	○	/	Section 12.2.1
	Interrupt positioning function	○	○	/	Section 12.2.2
Infinite feed function (setting degree)	When the unit of position data of the automatic operation or manual operation is set to degree, the detection of [AL. E3.1 Multi-revolution counter travel distance excess warning] is disabled and the home position is retained even if the servo motor rotates 32768 revolutions or more are in the same direction. Thus, the current position is restored after the power is cycled. This function can be used with the absolute position detection system. This is available with servo amplifiers with software version B7 or later.	○	○	/	Section 12.3
Simple cam function	This function enables the encoder following function, mark sensor input compensation function, synchronous operation using positioning data, and synchronous interpolation operation. This function is not available with the servo amplifier to which the MR-D30 unit has been connected. This is available with servo amplifiers with software version B7 or later. This function will be available with MR-J4-03A6-RJ servo amplifiers in the future.	○	○	/	Section 12.1

1. FUNCTIONS AND CONFIGURATION

Function	Description	Control mode			Detailed explanation
		CP/BCD	CL	P/S	
home position return	Dog type/count type/data setting type/stopper type/home position ignorance/dog type rear end reference/count type front end reference/dog cradle type/dog type last Z-phase reference/dog type Z-phase reference/dogless Z-phase reference	○	○	○	Section 4.4 Section 5.4
	Torque limit changing dog type/torque limit changing data set type	○	○	○	Section 6.4
High-resolution encoder	High-resolution encoder of 4194304 pulses/rev is used as the encoder of the rotary servo motor compatible with the MELSERVO-J4 series. However, the encoder resolution of the rotary servo motor compatible with MR-J4-03A6-RJ servo amplifiers will be 262144 pulses/rev.	○	○	○	
Absolute position detection system	Home position return is required only once, and not required at every power-on. Only "12.1 Summary" and "12.2 Battery" will be appropriate references for the positioning mode.	○	○	○	MR-J4- _A_ chapter 12
Gain switching function	You can switch gains during rotation/stop, and can use input devices to switch gains during operation.	○	○	○	MR-J4- _A_ section 7.2
Advanced vibration suppression control II	This function suppresses vibration at the arm end or residual vibration.	○	○	○	MR-J4- _A_ section 7.1.5
Machine resonance suppression filter	This is a filter function (notch filter) which decreases the gain of the specific frequency to suppress the resonance of the mechanical system.	○	○	○	MR-J4- _A_ section 7.1.1
Shaft resonance suppression filter	When a load is mounted to the servo motor shaft, resonance by shaft torsion during driving may generate a mechanical vibration at high frequency. The shaft resonance suppression filter suppresses the vibration.	○	○	○	MR-J4- _A_ section 7.1.3
Adaptive filter II	Servo amplifier detects mechanical resonance and sets filter characteristics automatically to suppress mechanical vibration.	○	○	○	MR-J4- _A_ section 7.1.2
Low-pass filter	Suppresses high-frequency resonance which occurs as servo system response is increased.	○	○	○	MR-J4- _A_ section 7.1.4
Machine analyzer function	Analyzes the frequency characteristic of the mechanical system by simply connecting an MR Configurator2 installed personal computer and servo amplifier. MR Configurator2 is necessary for this function.	○	○	○	
Robust filter	This function provides better disturbance response in case low response level that load to motor inertia ratio is high for such as roll send axes.	○	○	○	[Pr. PE41]
Slight vibration suppression control	Suppresses vibration of ± 1 pulse generated at a servo motor stop.	○	○	○	[Pr. PB24]
Electronic gear	Position commands can be multiplied by 1/864 to 33935.	○	○	○	[Pr. PA06]
	Position commands can be multiplied by 1/9999 to 9999.	○	○	○	[Pr. PA07]
Auto tuning	Automatically adjusts the gain to optimum value if load applied to the servo motor shaft varies.	○	○	○	MR-J4- _A_ section 6.3
Brake unit	Used when the regenerative option cannot provide enough regenerative power. Can be used for the 5 kW or more servo amplifier. This is not available with MR-J4-03A6-RJ servo amplifiers.	○	○	○	MR-J4- _A_ section 11.3
Power regeneration converter	Used when the regenerative option cannot provide enough regenerative power. Can be used for the 5 kW or more servo amplifier. This is not available with MR-J4-03A6-RJ servo amplifiers.	○	○	○	MR-J4- _A_ section 11.4
Regenerative option	Used when the built-in regenerative resistor of the servo amplifier does not have sufficient regenerative capability for the regenerative power generated. This is not available with MR-J4-03A6-RJ servo amplifiers.	○	○	○	MR-J4- _A_ section 11.2
Alarm history clear	Alarm history is cleared.	○	○	○	[Pr. PC18]
Input signal selection (device settings)	ST1 (Forward rotation start), ST2 (Reverse rotation start), and SON (Servo-on) and other input device can be assigned to any pins.	○	○	○	[Pr. PD04] [Pr. PD06] [Pr. PD08] [Pr. PD10] [Pr. PD12] [Pr. PD14] [Pr. PD18] [Pr. PD20] [Pr. PD22] [Pr. PD44] [Pr. PD46]

1. FUNCTIONS AND CONFIGURATION

Function	Description	Control mode			Detailed explanation
		CP/BCD	CL	PS	
Output signal selection (device settings)	The output devices including MBR (Electromagnetic brake interlock) can be assigned to certain pins of the CN1 connector. However, [Pr. PD47] is not available with MR-J4-03A6-RJ servo amplifiers.	○	○	○	[Pr. PD23] to [Pr. PD26] [Pr. PD28] [Pr. PD47]
Output signal (DO) forced output	Output signal can be forced on/off independently of the servo status. Use this function for checking output signal wiring, etc.	○	○	○	Section 3.1.8 Section 3.2.8 MR-J4- <u>A</u> section 4.5.8 section 18.5.9
Command pulse selection	Supports only A-axis/B-axis pulse trains.	○	○	○	[Pr. PA13]
Torque limit	Servo motor torque can be limited to any value.	○	○	○	[Pr. PA11] [Pr. PA12]
Status display	Servo status is shown on the 5-digit, 7-segment LED display. For MR-J4-03A6-RJ servo amplifiers, the servo status is shown on the 3-digit, 7-segment LED display.	○	○	○	Section 3.1.2 Section 3.2.2
External I/O signal display	On/off statuses of external I/O signals are shown on the display.	○	○	○	Section 3.1.7 Section 3.2.7
Alarm code output	If an alarm has occurred, the corresponding alarm number is outputted in 3-bit code.	○	○	○	Chapter 8
Test operation mode	Jog operation/positioning operation/motor-less operation/DO forced output/program operation/single-step feed However, MR Configurator2 is necessary for positioning operation, program operation, and single-step feed.	○	○	○	Section 3.1.8 Section 3.1.9 Section 3.2.8 Section 3.2.9 MR-J4- <u>A</u> section 4.5.8 section 4.5.9 section 18.5.9 section 18.5.10
Analog monitor output	Servo status is outputted in terms of voltage in real time.	○	○	○	[Pr. PC14] [Pr. PC15]
MR Configurator2	Using a personal computer, you can perform the parameter setting, test operation, monitoring, and others.	○	○	○	MR-J4- <u>A</u> section 11.7
Linear servo system	Linear servo system can be configured using a linear servo motor and linear encoder. For the home position return, refer to the chapter indicated in the detailed explanation field and section 4.4.15. This is not available with MR-J4-03A6-RJ servo amplifiers.	○	○	○	MR-J4- <u>A</u> chapter 15
Direct drive servo system	The direct drive servo system can be configured to drive a direct drive motor. This is not available with MR-J4-03A6-RJ servo amplifiers.	○	○	○	MR-J4- <u>A</u> chapter 16
Fully closed loop system	Fully closed loop system can be configured using the load-side encoder. For the home position return, refer to the chapter indicated in the detailed explanation field and section 4.4.16. This is not available with MR-J4-03A6-RJ servo amplifiers.	○	○	○	MR-J4- <u>A</u> chapter 17
One-touch tuning	Gain adjustment is performed just by one click on a certain button on MR Configurator2 or operation section.	○	○	○	MR-J4- <u>A</u> section 6.2 section 18.5.4

1. FUNCTIONS AND CONFIGURATION

Function	Description	Control mode			Detailed explanation
		CP/BCD	CL	PS	
SEMI-F47 function	This function which complies with the SEMI-F47 standard enables to avoid triggering [AL. 10 Undervoltage] using the electrical energy charged in the capacitor in case that an instantaneous power failure occurs during operation. This is not available with MR-J4-03A6-RJ servo amplifiers.	<input type="radio"/>	<input type="radio"/>	<input type="radio"/>	MR-J4- _A_ section 7.4 [Pr. PA20] [Pr. PF25]
Tough drive function	This function makes the equipment continue operating even under the condition that an alarm occurs. The tough drive function includes two types: the vibration tough drive and the instantaneous power failure tough drive. MR-J4-03A6-RJ servo amplifiers are not compatible with the instantaneous power failure tough drive.	<input type="radio"/>	<input type="radio"/>	<input type="radio"/>	MR-J4- _A_ section 7.3
Drive recorder function	This function continuously monitors the servo status and records the status transition before and after an alarm for a fixed period of time. You can check the recorded data on the drive recorder window on MR Configurator2 by clicking the "Graph" button. However, the drive recorder will not operate on the following conditions. 1.You are using the graph function of MR Configurator2. 2.You are using the machine analyzer function. 3.[Pr. PF21] is set to "-1".	<input type="radio"/>	<input type="radio"/>	<input type="radio"/>	[Pr. PA23]
STO function	This amplifier complies with the STO function as functional safety of IEC/EN 61800-5-2. You can create a safety system for the equipment easily. This is not available with MR-J4-03A6-RJ servo amplifiers.	<input type="radio"/>	<input type="radio"/>	<input type="radio"/>	MR-J4- _A_ chapter 13
Servo amplifier life diagnosis function	You can check the cumulative energization time and the number of on/off times of the inrush relay. This function gives an indication of the replacement time for parts of the servo amplifier including a capacitor and a relay before they malfunction. MR Configurator2 is necessary for this function.	<input type="radio"/>	<input type="radio"/>	<input type="radio"/>	
Power monitoring function	This function calculates the power running energy and the regenerative power from the data in the servo amplifier such as speed and current. Power consumption and others are displayed on MR Configurator2.	<input type="radio"/>	<input type="radio"/>	<input type="radio"/>	
Machine diagnosis function	From the data in the servo amplifier, this function estimates the friction and vibrational component of the drive system in the equipment and recognizes an error in the machine parts, including a ball screw and bearing. MR Configurator2 is necessary for this function.	<input type="radio"/>	<input type="radio"/>	<input type="radio"/>	
Lost motion compensation function	This function improves the response delay occurred when the machine moving direction is reversed. This is used with servo amplifiers with software version B4 or later. Check the software version of the servo amplifier with MR Configurator2.	<input type="radio"/>	<input type="radio"/>	<input type="radio"/>	MR-J4- _A_ section 7.6
Super trace control	This function sets constant and uniform acceleration/deceleration droop pulses to almost 0. This is used with servo amplifiers with software version B4 or later. Check the software version of the servo amplifier with MR Configurator2.	<input type="radio"/>	<input type="radio"/>	<input type="radio"/>	MR-J4- _A_ section 7.7
Limit switch	Limits travel intervals using LSP (Forward rotation stroke end) and LSN (Reverse rotation stroke end).	<input type="radio"/>	<input type="radio"/>	<input type="radio"/>	
S-pattern acceleration/deceleration	Enables smooth acceleration and deceleration. Set S-pattern acceleration/deceleration time constants with [Pr. PC03]. Compared with linear acceleration/deceleration, the acceleration/deceleration time will be longer for the S-pattern acceleration/deceleration time constants regardless of command speed.	<input type="radio"/>	<input type="radio"/>	<input type="radio"/>	[Pr. PC03] section 5.2.2
Software limit	Limits travel intervals by address using parameters. Enables the same function with the limit switch by setting parameters.	<input type="radio"/>	<input type="radio"/>	<input type="radio"/>	Section 7.4
Analog override	Limits a servo motor speed with analog inputs. A value can be changed from 0% to 200% for a set speed.	<input type="radio"/>	<input type="radio"/>	<input type="radio"/>	Section 2.4
Digital override	A commanded speed multiplied by an override value selected with OVR (Override selection) will be an actual servo motor speed. A value can be changed from 0% to 360% for a set speed.	<input type="radio"/>	<input type="radio"/>	<input type="radio"/>	[Pr. PT42] [Pr. PT43] section 6.4.4 (2)

1. FUNCTIONS AND CONFIGURATION

Function	Description	Control mode			Detailed explanation
		CP/BCD	CL	PS	
Teaching function	After an operation travels to a target position with a JOG operation or manual pulse generator operation, pushing the SET button of the operation part or turning on TCH (Teach) will import position data.	○	/	/	Section 3.1.10 Section 3.2.10
MR-D01 extension I/O unit	MR-D01 is an extension I/O unit that can extend the input/output signals of MR-J4-_A_-RJ servo amplifiers. MR-D01 extension I/O unit is available with servo amplifiers with software version B7 or later.	○	○	○	Chapter 11
Modbus-RTU communication function	The Modbus protocol uses dedicated message frames for the serial communication between a master and slaves. Using the functions in the message frames enables to read or write data from/to parameters, write input commands, and check operation status of servo amplifiers. When the indexer method is used, there are functional restrictions. This function is supported by MR-J4-_A_-RJ servo amplifiers with a capacity of 100 W or more manufactured in November, 2014 or later. This function will be available with MR-J4-03A6-RJ servo amplifiers in the future.	○	○	○	MR-J4-_A_-RJ Servo Amplifier Instruction Manual (Modbus-RTU Protocol)
High-resolution analog input (VC)	The analog input resolution can be increased to 16 bits. This function is available with servo amplifiers manufactured in November 2014 or later. This is not available with MR-J4-03A6-RJ servo amplifiers.	○	○	/	[Pr. PC60]

1. FUNCTIONS AND CONFIGURATION

1.4 Configuration including peripheral equipment



● Connecting a servo motor of the wrong axis to U, V, W, or CN2 of the servo amplifier may cause a malfunction.

POINT

● Equipment other than the servo amplifier and servo motor are optional or recommended products.

(1) MR-J4-_A_-RJ 100 W or more

The following illustration is an example of MR-J4-20A-RJ.

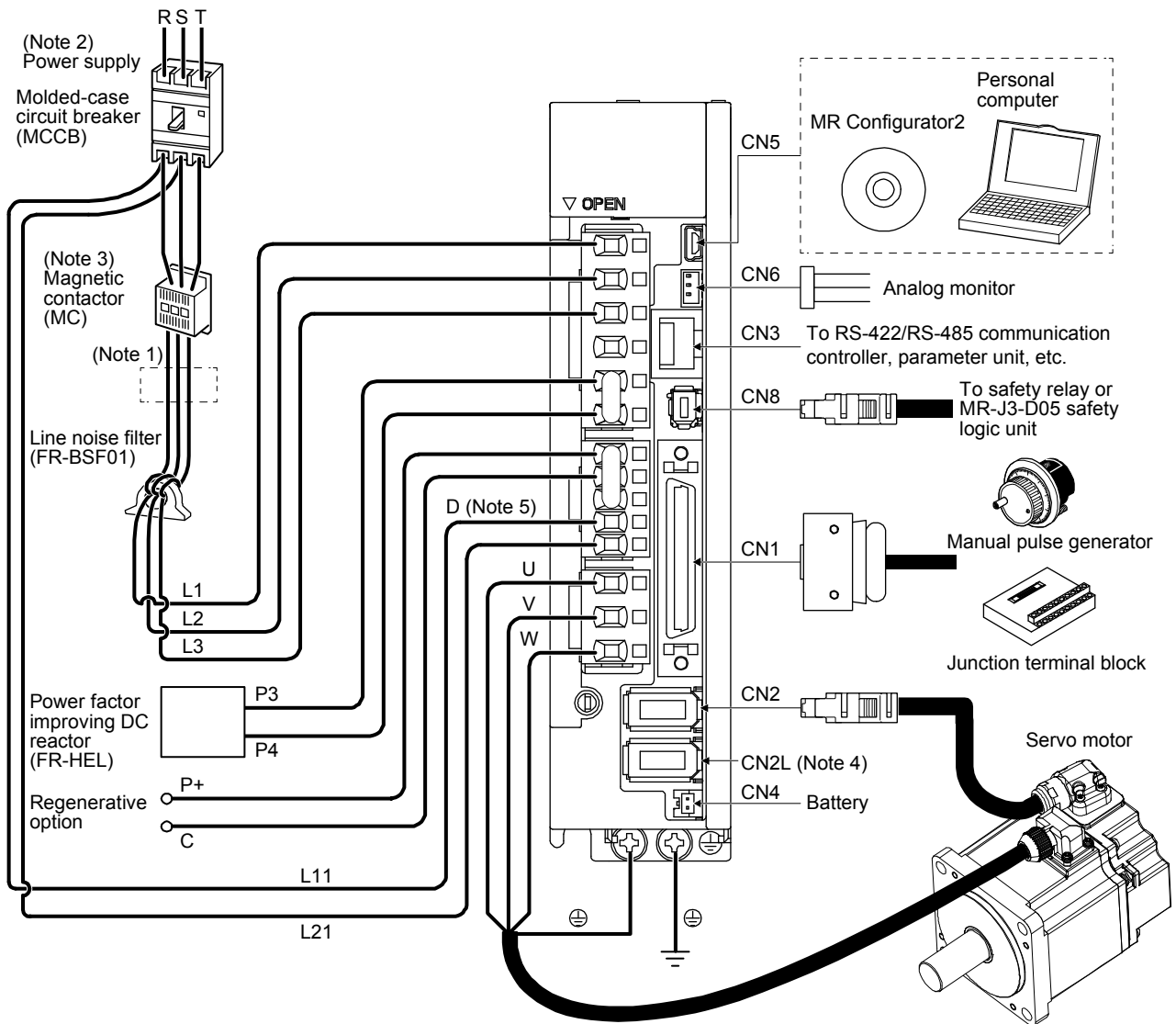

1. FUNCTIONS AND CONFIGURATION

- Note
1. The power factor improving AC reactor can also be used. In this case, the power factor improving DC reactor cannot be used. When not using the power factor improving DC reactor, short P3 and P4.
 2. A 1-phase 200 V AC to 240 V AC power supply may be used with the servo amplifier of MR-J4-200A-RJ or less. For 1-phase 200 V AC to 240 V AC, connect the power supply to L1 and L3. Leave L2 open. For power supply specifications, refer to section 1.3 of "MR-J4-_A_(-RJ) Servo Amplifier Instruction Manual".
 3. Depending on the main circuit voltage and operation pattern, bus voltage decreases, and that may cause the forced stop deceleration to shift to the dynamic brake deceleration. When dynamic brake deceleration is not required, slow the time to turn off the magnetic contactor.
 4. When using MR-J4-_A_-RJ servo amplifiers with a capacity of 100 W or more in the linear servo system or in the fully closed loop system, connect an external encoder to this connector. Refer to Table 1.1 of "MR-J4-_A_(-RJ) Servo Amplifier Instruction Manual" and "Linear Encoder Instruction Manual" for the connectible external encoders.
 5. Always connect between P+ and D terminals. When using the regenerative option, refer to section 11.2 of "MR-J4-_A_(-RJ) Servo Amplifier Instruction Manual".

(2) MR-J4-03A6-RJ

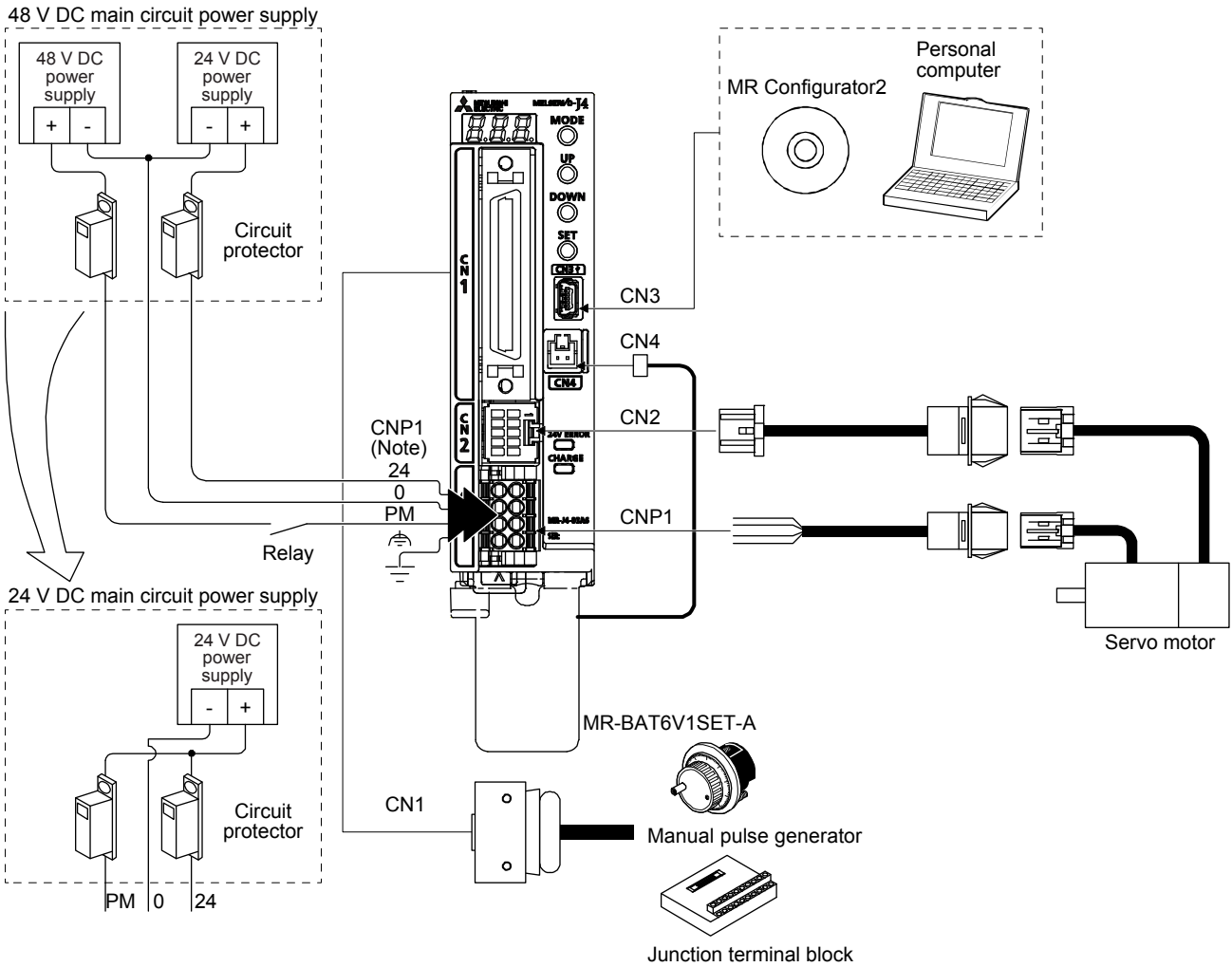

Note. For details, refer to section 18.3.2 of "MR-J4-_A_(-RJ) Servo Amplifier Instruction Manual".

2. SIGNALS AND WIRING

2. SIGNALS AND WIRING

⚠ WARNING

- Any person who is involved in wiring should be fully competent to do the work.
- Before wiring, turn off the power and wait for 15 minutes or more until the charge lamp turns off. Then, confirm that the voltage between P+ and N- is safe with a voltage tester and others. Otherwise, an electric shock may occur. In addition, when confirming whether the charge lamp is off or not, always confirm it from the front of the servo amplifier.
- Ground the servo amplifier and servo motor securely.
- Do not attempt to wire the servo amplifier and servo motor until they have been installed. Otherwise, it may cause an electric shock.
- The cables should not be damaged, stressed, loaded, or pinched. Otherwise, it may cause an electric shock.
- To avoid an electric shock, insulate the connections of the power supply terminals.

- Wire the equipment correctly and securely. Otherwise, the servo motor may operate unexpectedly, resulting in injury.
- Connect cables to the correct terminals. Otherwise, a burst, damage, etc. may occur.
- Ensure that polarity (+/-) is correct. Otherwise, a burst, damage, etc. may occur.
- The surge absorbing diode installed to the DC relay for control output should be fitted in the specified direction. Otherwise, the emergency stop and other protective circuits may not operate.

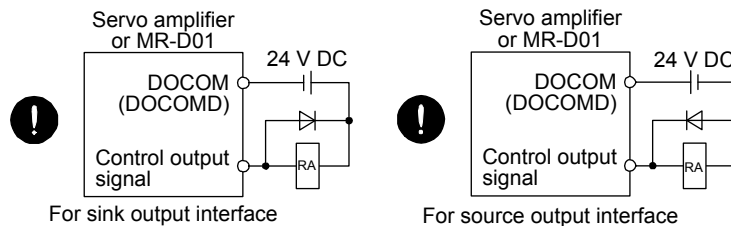

⚠ CAUTION

- Use a noise filter, etc. to minimize the influence of electromagnetic interference. Electromagnetic interference may be given to the electronic equipment used near the servo amplifier.
- Do not install a power capacitor, surge killer or radio noise filter (optional FR-BIF(-H)) with the power line of the servo motor.
- When using the regenerative resistor, switch power off with the alarm signal. Otherwise, a transistor fault or the like may overheat the regenerative resistor, causing a fire.
- Do not modify the equipment.
- Connect the servo amplifier power output (U/V/W) to the servo motor power input (U/V/W) directly. Do not let a magnetic contactor, etc. intervene. Otherwise, it may cause a malfunction.

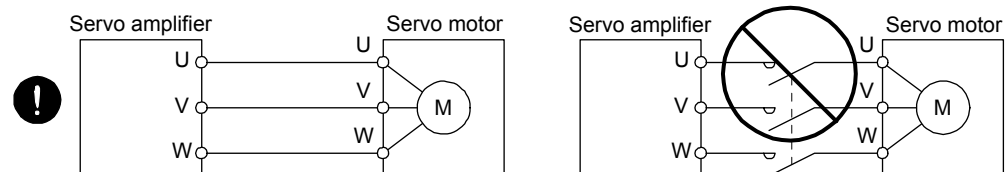

- Connecting a servo motor of the wrong axis to U, V, W, or CN2 of the servo amplifier may cause a malfunction.

2. SIGNALS AND WIRING

The following items are the same as MR-J4-__A__-RJ servo amplifiers. For details, refer to each section indicated in the detailed explanation field. "MR-J4-__A__" means "MR-J4-__A__(-RJ) Servo Amplifier Instruction Manual".

Item	Detailed explanation	
	MR-J4-__A__-RJ 100 W or more	MR-J4-03A6-RJ
Input power supply circuit	MR-J4-__A__ section 3.1	MR-J4-__A__ section 18.3.1
Explanation of power supply system (except section 2.6 Power-on sequence)	MR-J4-__A__ section 3.3	MR-J4-__A__ section 18.3.2
Detailed explanation of signals	MR-J4-__A__ section 3.6	
Forced stop deceleration function	MR-J4-__A__ section 3.7	
Alarm occurrence timing chart	MR-J4-__A__ section 3.8	MR-J4-__A__ section 18.3.8
Interface (except for section 2.5 Internal connection diagram)	MR-J4-__A__ section 3.9	
Servo motor with an electromagnetic brake	MR-J4-__A__ section 3.10	
Grounding	MR-J4-__A__ section 3.11	MR-J4-__A__ section 18.3.10

2. SIGNALS AND WIRING

2.1 I/O signal connection example

2.1.1 MR-J4-_A_-RJ 100 W or more

(1) Point table method

POINT
<ul style="list-style-type: none"> Assign the following output devices to CN1-22, CN1-23, and CN1-25 pins with [Pr. PD23], [Pr. PD24], and [Pr. PD26]. CN1-22: CPO (Rough match) CN1-23: ZP (Home position return completion) CN1-25: MEND (Travel completion)

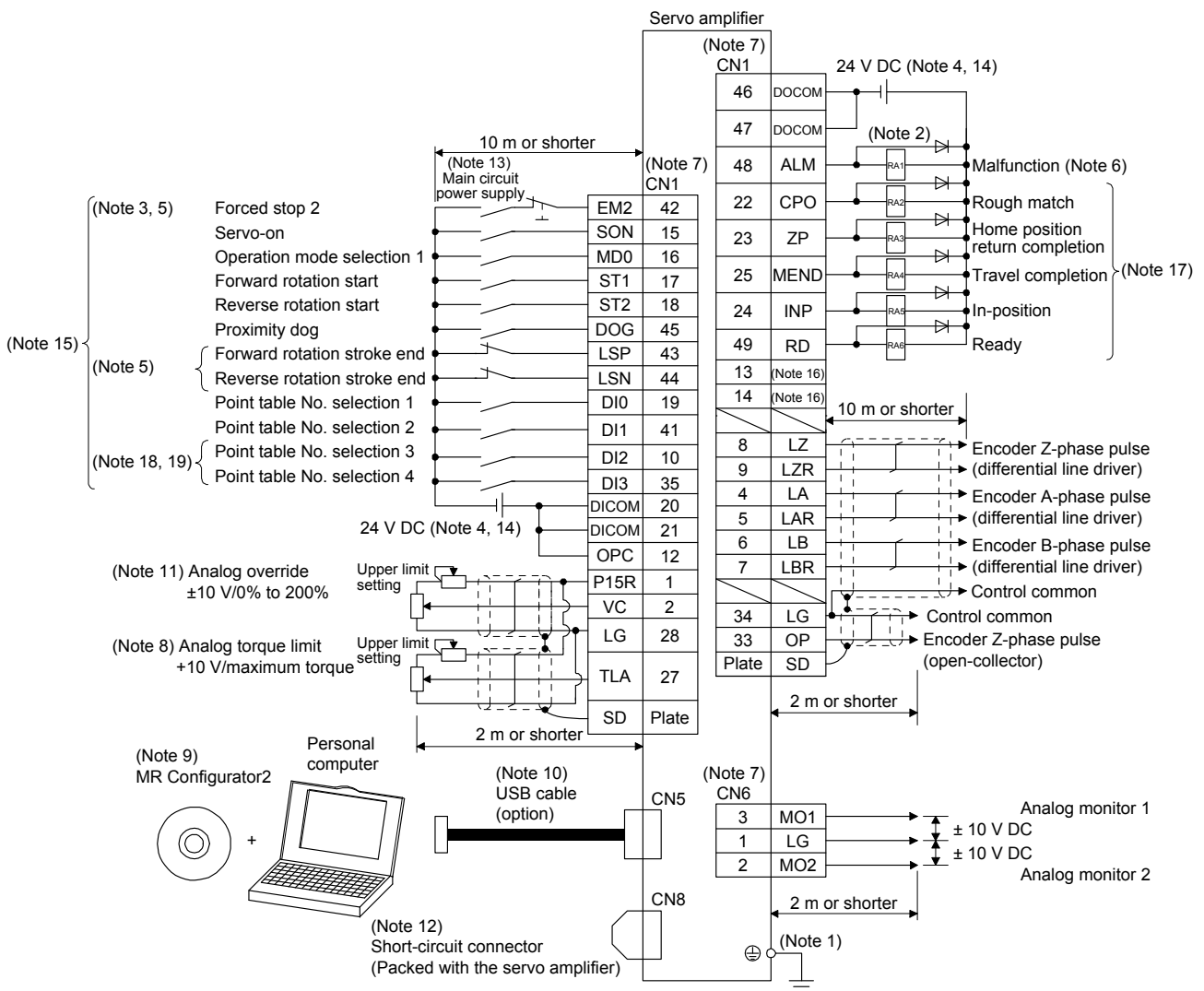

2. SIGNALS AND WIRING

- Note
- To prevent an electric shock, always connect the protective earth (PE) terminal (marked \oplus) of the servo amplifier to the protective earth (PE) of the cabinet.
 - Connect the diode in the correct direction. If it is connected reversely, the servo amplifier will malfunction and will not output signals, disabling EM2 (Forced stop 2) and other protective circuits.
 - The forced stop switch (normally closed contact) must be installed.
 - Supply 24 V DC \pm 10% to interfaces from outside. The total current capacity is up to 500 mA. 500 mA is the value applicable when all I/O signals are used. The current capacity can be decreased by reducing the number of I/O points. Refer to section 3.9.2 (1) of "MR-J4-_A_(-RJ) Servo Amplifier Instruction Manual" that gives the current value necessary for the interface. A 24 V DC power supply can be used for both input signal and output signal.
 - When starting operation, always turn on EM2 (Forced stop 2), LSP (Forward rotation stroke end) and LSN (Reverse rotation stroke end) (normally closed contact).
 - ALM (Malfunction) turns on in normal alarm-free condition (normally closed contact).
 - The pins with the same signal name are connected in the servo amplifier.
 - TLA will be available when TL (External torque limit selection) is enabled with [Pr. PD04], [Pr. PD06], [Pr. PD08], [Pr. PD10], [Pr. PD12], [Pr. PD14], [Pr. PD18], [Pr. PD20], [Pr. PD22], [Pr. PD44], and [Pr. PD46]. (Refer to section 3.6.1 (5) of "MR-J4-_A_(-RJ) Servo Amplifier Instruction Manual".)
 - Use SW1DNC-MRC2-_. (Refer to section 11.7 of "MR-J4-_A_(-RJ) Servo Amplifier Instruction Manual".)
 - Controllers or parameter units can also be connected via the CN3 connector with the RS-422/RS-485 communication. Note that using the USB communication function (CN5 connector) prevents the RS-422/RS-485 communication function (CN3 connector) from being used, and vice versa. They cannot be used together.

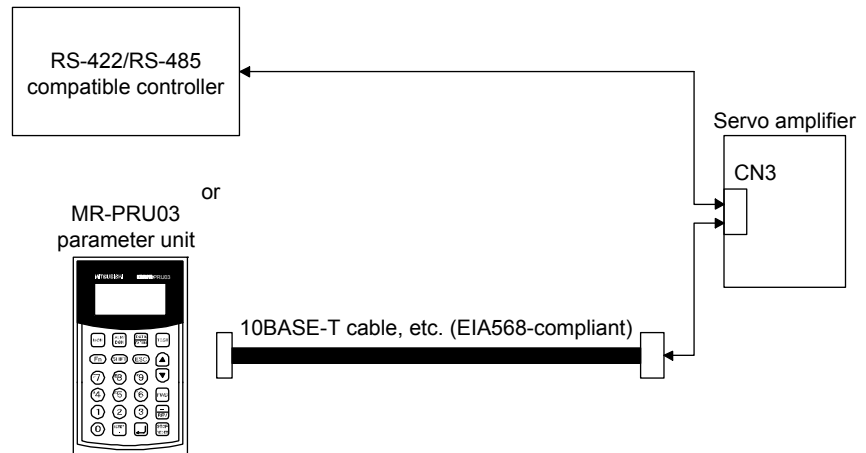

- Use an external power supply when inputting a negative voltage.
- When not using the STO function, attach the short-circuit connector came with a servo amplifier.
- Configure a circuit to turn off EM2 when the main circuit power is turned off to prevent an unexpected restart of the servo amplifier.
- This diagram shows sink I/O interface.
- The device can be changed with [Pr. PD04], [Pr. PD06], [Pr. PD08], [Pr. PD10], [Pr. PD12], [Pr. PD14], [Pr. PD18], [Pr. PD20], [Pr. PD22], [Pr. PD44], and [Pr. PD46].
- These output devices are not assigned by default. Assign the output device with [Pr. PD47] as necessary.
- These devices are recommended assignments. The device can be changed by [Pr. PD23] to [Pr. PD26], and [Pr. PD28].
- DI2 and DI3 are assigned to the CN1-10 and CN1-35 pins by default. When connecting a manual pulse generator, change them with [Pr. PD44] and [Pr. PD46]. Refer to section 9.1 for details of the manual pulse generator.
- Supply + of 24 V DC to OPC (Power input for open-collector sink interface) when input devices are assigned to the CN1-10 pin and the CN1-35 pin. They are not used with source input interface. For the positioning mode, input devices (DI2 and DI3) are assigned by default.

2. SIGNALS AND WIRING

(2) Program method

POINT
<ul style="list-style-type: none"> Assign the following output devices to CN1-22, CN1-23, and CN1-25 pins with [Pr. PD23], [Pr. PD24], and [Pr. PD26]. CN1-22: CPO (Rough match) CN1-23: ZP (Home position return completion) CN1-25: MEND (Travel completion)

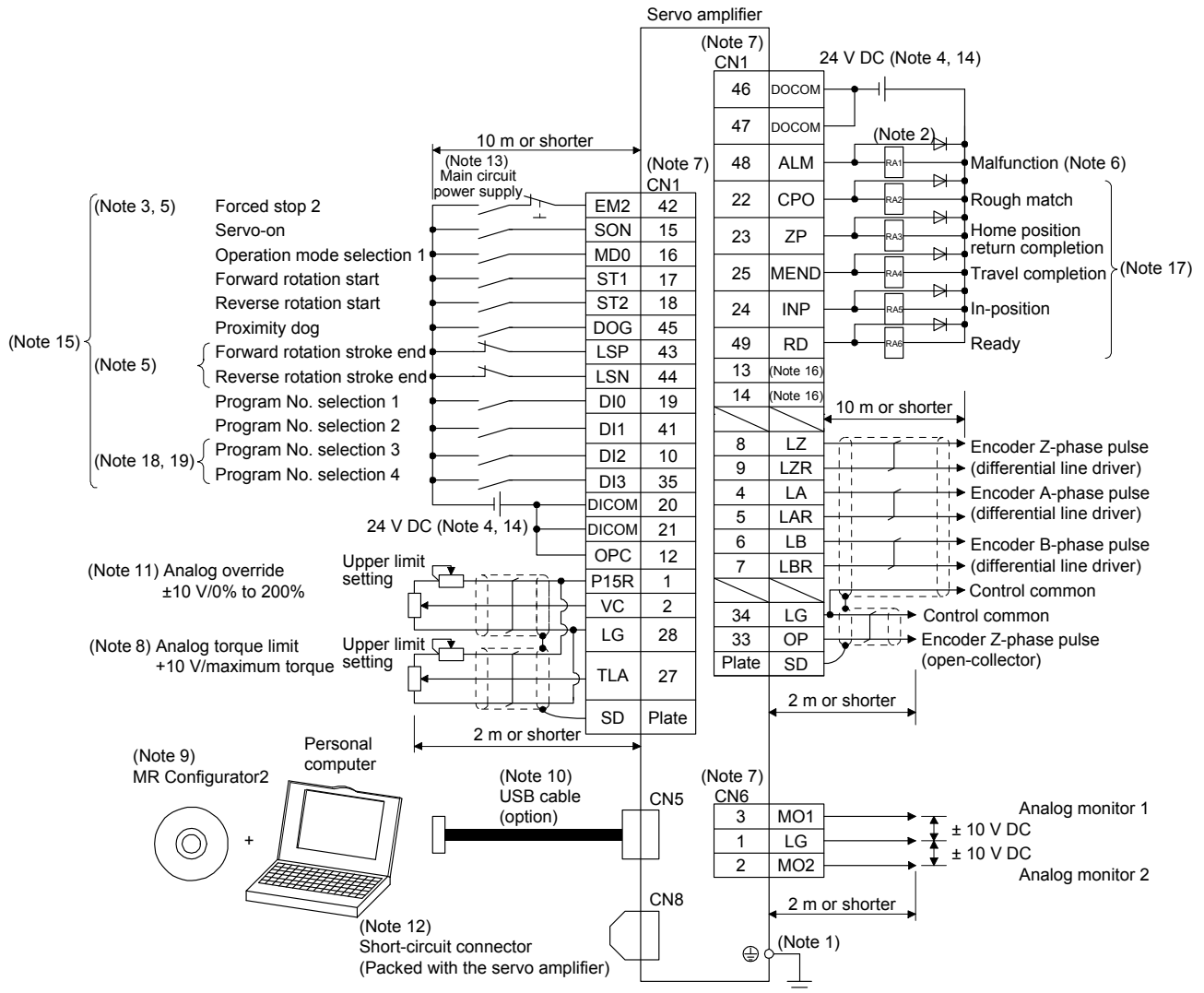

2. SIGNALS AND WIRING

- Note
- To prevent an electric shock, always connect the protective earth (PE) terminal (marked \oplus) of the servo amplifier to the protective earth (PE) of the cabinet.
 - Connect the diode in the correct direction. If it is connected reversely, the servo amplifier will malfunction and will not output signals, disabling EM2 (Forced stop 2) and other protective circuits.
 - The forced stop switch (normally closed contact) must be installed.
 - Supply 24 V DC \pm 10% to interfaces from outside. The total current capacity is up to 500 mA. 500 mA is the value applicable when all I/O signals are used. The current capacity can be decreased by reducing the number of I/O points. Refer to section 3.9.2 (1) of "MR-J4-_A_(-RJ) Servo Amplifier Instruction Manual" that gives the current value necessary for the interface. A 24 V DC power supply can be used for both input signal and output signal.
 - When starting operation, always turn on EM2 (Forced stop 2), LSP (Forward rotation stroke end) and LSN (Reverse rotation stroke end) (normally closed contact).
 - ALM (Malfunction) turns on in normal alarm-free condition (normally closed contact).
 - The pins with the same signal name are connected in the servo amplifier.
 - TLA will be available when TL (External torque limit selection) is enabled with [Pr. PD04], [Pr. PD06], [Pr. PD08], [Pr. PD10], [Pr. PD12], [Pr. PD14], [Pr. PD18], [Pr. PD20], [Pr. PD22], [Pr. PD44], and [Pr. PD46]. (Refer to section 3.6.1 (5) of "MR-J4-_A_(-RJ) Servo Amplifier Instruction Manual".)
 - Use SW1DNC-MRC2-_. (Refer to section 11.7 of "MR-J4-_A_(-RJ) Servo Amplifier Instruction Manual".)
 - Controllers or parameter units can also be connected via the CN3 connector with the RS-422/RS-485 communication. Note that using the USB communication function (CN5 connector) prevents the RS-422/RS-485 communication function (CN3 connector) from being used, and vice versa. They cannot be used together.

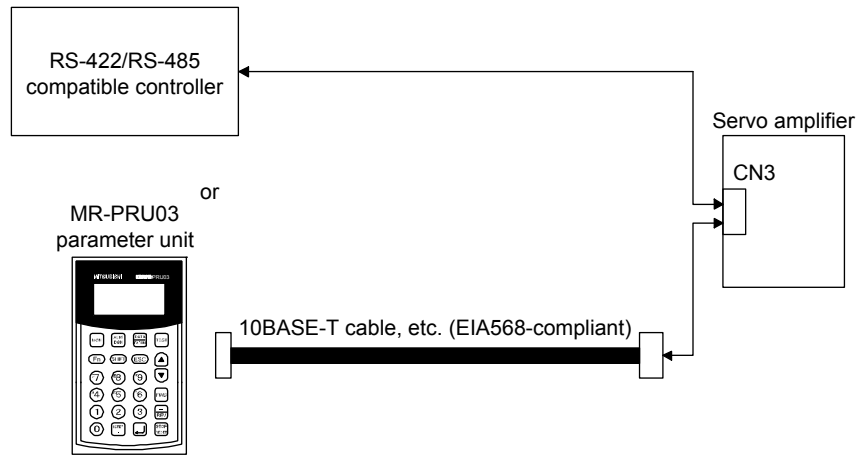

- Use an external power supply when inputting a negative voltage.
- When not using the STO function, attach the short-circuit connector came with a servo amplifier.
- Configure a circuit to turn off EM2 when the main circuit power is turned off to prevent an unexpected restart of the servo amplifier.
- This diagram shows sink I/O interface.
- The device can be changed with [Pr. PD04], [Pr. PD06], [Pr. PD08], [Pr. PD10], [Pr. PD12], [Pr. PD14], [Pr. PD18], [Pr. PD20], [Pr. PD22], [Pr. PD44], and [Pr. PD46].
- These output devices are not assigned by default. Assign the output device with [Pr. PD47] as necessary.
- These devices are recommended assignments. The device can be changed by [Pr. PD23] to [Pr. PD26], and [Pr. PD28].
- DI2 and DI3 are assigned to the CN1-10 and CN1-35 pins by default. When connecting a manual pulse generator, change them with [Pr. PD44] and [Pr. PD46]. Refer to section 9.1 for details of the manual pulse generator.
- Supply + of 24 V DC to OPC (Power input for open-collector sink interface) when input devices are assigned to the CN1-10 pin and the CN1-35 pin. They are not used with source input interface. For the positioning mode, input devices (DI2 and DI3) are assigned by default.

2. SIGNALS AND WIRING

(3) Indexer method

POINT
<ul style="list-style-type: none"> ● In the indexer method, assign the following input device to CN1-18 pin with [Pr. PD10]. CN1-18: MD1 (Operation mode selection 2) ● Assign the following output devices to CN1-22, CN1-23, and CN1-25 pins with [Pr. PD23], [Pr. PD24], and [Pr. PD26]. CN1-22: CPO (Rough match) CN1-23: ZP (Home position return completion) CN1-25: MEND (Travel completion)

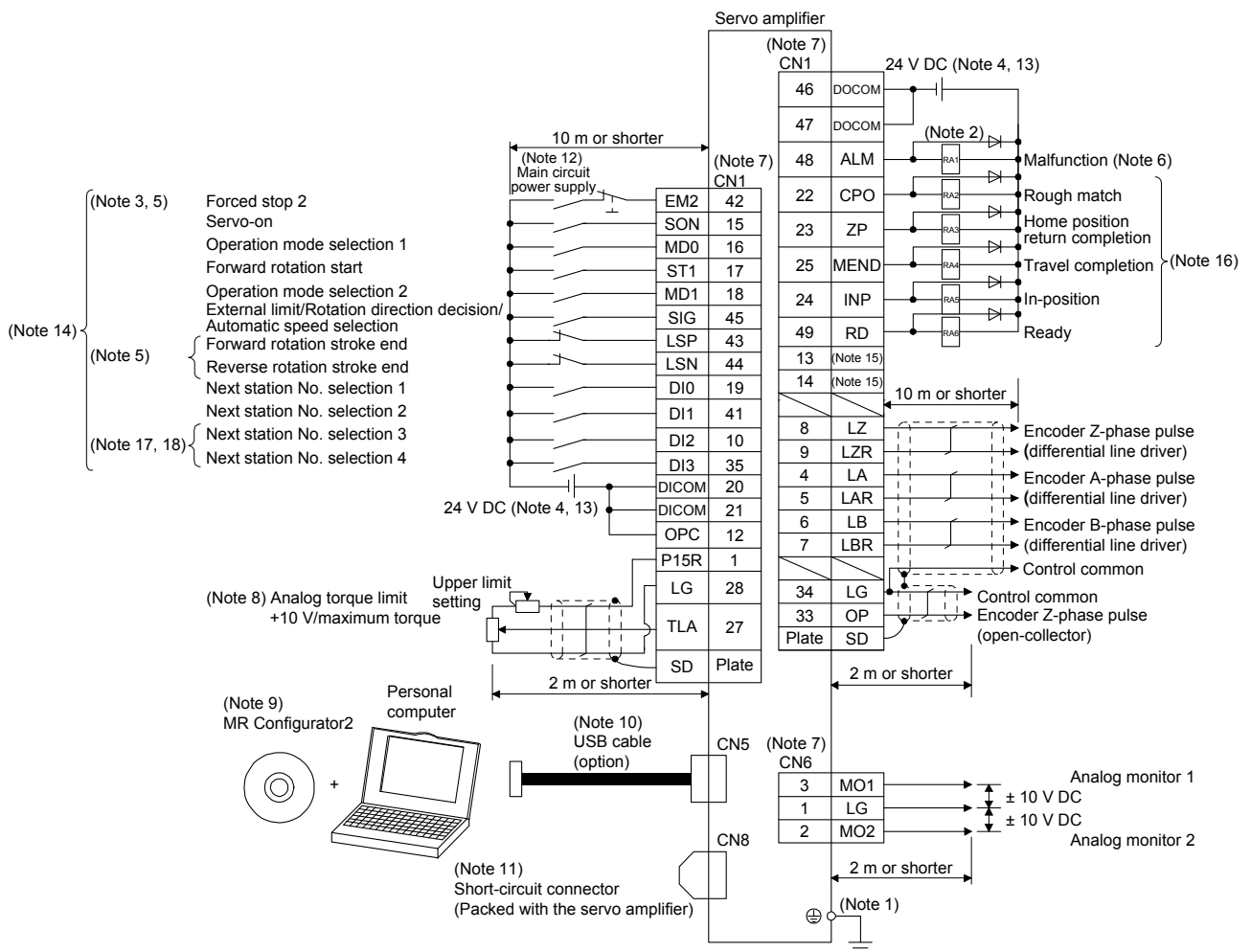

2. SIGNALS AND WIRING

- Note
- To prevent an electric shock, always connect the protective earth (PE) terminal (marked \oplus) of the servo amplifier to the protective earth (PE) of the cabinet.
 - Connect the diode in the correct direction. If it is connected reversely, the servo amplifier will malfunction and will not output signals, disabling EM2 (Forced stop 2) and other protective circuits.
 - The forced stop switch (normally closed contact) must be installed.
 - Supply 24 V DC \pm 10% to interfaces from outside. The total current capacity is up to 500 mA. 500 mA is the value applicable when all I/O signals are used. The current capacity can be decreased by reducing the number of I/O points. Refer to section 3.9.2 (1) of "MR-J4-_A_(-RJ) Servo Amplifier Instruction Manual" that gives the current value necessary for the interface. A 24 V DC power supply can be used for both input signal and output signal.
 - When starting operation, always turn on EM2 (Forced stop 2), LSP (Forward rotation stroke end) and LSN (Reverse rotation stroke end) (normally closed contact).
 - ALM (Malfunction) turns on in normal alarm-free condition (normally closed contact).
 - The pins with the same signal name are connected in the servo amplifier.
 - TLA will be available when TL (External torque limit selection) is enabled with [Pr. PD04], [Pr. PD06], [Pr. PD08], [Pr. PD10], [Pr. PD12], [Pr. PD14], [Pr. PD18], [Pr. PD20], [Pr. PD22], [Pr. PD44], and [Pr. PD46]. (Refer to section 3.6.1 (5) of "MR-J4-_A_(-RJ) Servo Amplifier Instruction Manual".)
 - Use SW1DNC-MRC2-_. (Refer to section 11.7 of "MR-J4-_A_(-RJ) Servo Amplifier Instruction Manual".)
 - Controllers or parameter units can also be connected via the CN3 connector with the RS-422/RS-485 communication. Note that using the USB communication function (CN5 connector) prevents the RS-422/RS-485 communication function (CN3 connector) from being used, and vice versa. They cannot be used together.

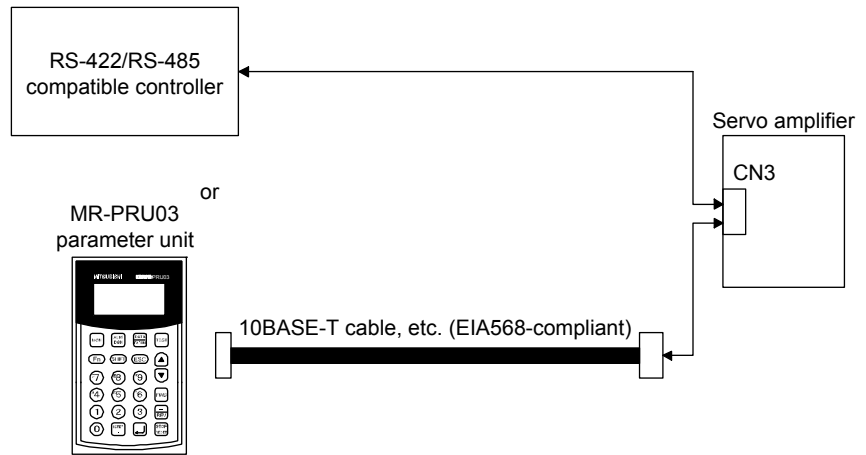

- When not using the STO function, attach the short-circuit connector came with a servo amplifier.
- Configure a circuit to turn off EM2 when the main circuit power is turned off to prevent an unexpected restart of the servo amplifier.
- This diagram shows sink I/O interface.
- The signals can be changed with [Pr. PD04], [Pr. PD06], [Pr. PD08], [Pr. PD10], [Pr. PD12], [Pr. PD14], [Pr. PD18], [Pr. PD20], [Pr. PD22], [Pr. PD44], and [Pr. PD46].
- These output devices are not assigned by default. Assign the output device with [Pr. PD47] as necessary.
- These devices are recommended assignments. The device can be changed by [Pr. PD23] to [Pr. PD26], and [Pr. PD28].
- DI2 and DI3 are assigned to the CN1-10 and CN1-35 pins by default. When connecting a manual pulse generator, change them with [Pr. PD44] and [Pr. PD46]. Refer to section 9.1 for details of the manual pulse generator.
- Supply + of 24 V DC to OPC (Power input for open-collector sink interface) when input devices are assigned to the CN1-10 pin and the CN1-35 pin. They are not used with source input interface. For the positioning mode, input devices (DI2 and DI3) are assigned by default.

2. SIGNALS AND WIRING

2.1.2 MR-J4-03A6-RJ

(1) Point table method

POINT
<ul style="list-style-type: none"> Assign the following output devices to CN1-22, CN1-23, and CN1-25 pins with [Pr. PD23], [Pr. PD24], and [Pr. PD26]. CN1-22: CPO (Rough match) CN1-23: ZP (Home position return completion) CN1-25: MEND (Travel completion)

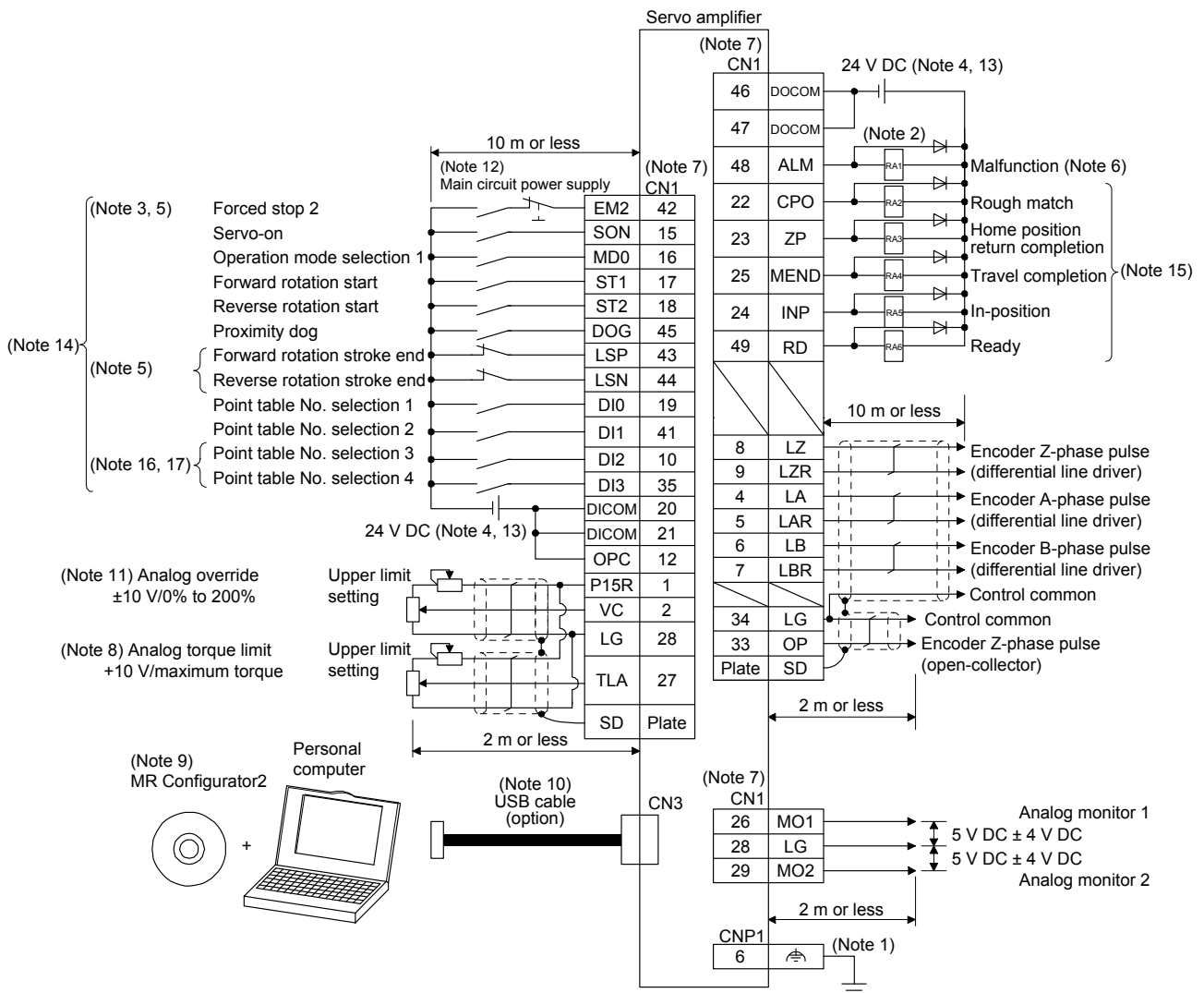

2. SIGNALS AND WIRING

- Note
1. To prevent an electric shock, always connect the CNP1 noiseless grounding terminal (⚡marked) of the servo amplifier to the grounding terminal of the cabinet.
 2. Connect the diode in the correct direction. If it is connected reversely, the servo amplifier will malfunction and will not output signals, disabling EM2 (Forced stop 2) and other protective circuits.
 3. The forced stop switch (normally closed contact) must be installed.
 4. Supply 24 V DC \pm 10% to interfaces from outside. The total current capacity of these power supplies must be 300 mA or lower. 300 mA is the value applicable when all I/O signals are used. The current capacity can be decreased by reducing the number of I/O points. Refer to section 3.9.2 (1) of "MR-J4-_A_(-RJ) Servo Amplifier Instruction Manual" that gives the current value necessary for the interface. A 24 V DC power supply can be used for both input signal and output signal. For 24 V DC power for I/O signal, use power other than 24 V DC power of servo amplifier control circuit power supply.
 5. When starting operation, always turn on EM2 (Forced stop 2), LSP (Forward rotation stroke end) and LSN (Reverse rotation stroke end). (Normally closed contact)
 6. ALM (Malfunction) turns on in normal alarm-free condition. (Normally closed contact)
 7. The pins with the same signal name are connected in the servo amplifier.
 8. TLA will be available when TL (External torque limit selection) is enabled with [Pr. PD04], [Pr. PD06], [Pr. PD08], [Pr. PD10], [Pr. PD12], [Pr. PD14], [Pr. PD18], [Pr. PD20], [Pr. PD22], [Pr. PD44], and [Pr. PD46]. (Refer to section 3.6.1 (5) of "MR-J4-_A_(-RJ) Servo Amplifier Instruction Manual".)
 9. Use SW1DNC MRC2-_. (Refer to "MR-J4-_A_(-RJ) Servo Amplifier Instruction Manual" section 11.7.)
 10. The USB communication function and RS-422 communication function are mutually exclusive. They cannot be used together.
 11. Use an external power supply when inputting a negative voltage.
 12. Configure a circuit to turn off EM2 when the main circuit power is turned off to prevent an unexpected restart of the servo amplifier.
 13. This diagram shows sink I/O interface.
 14. The devices can be changed with [Pr. PD04], [Pr. PD06], [Pr. PD08], [Pr. PD10], [Pr. PD12], [Pr. PD14], [Pr. PD18], [Pr. PD20], [Pr. PD22], [Pr. PD44], and [Pr. PD46].
 15. Recommended device assignments are shown. The device can be changed by [Pr. PD23] to [Pr. PD26], and [Pr. PD28].
 16. DI2 and DI3 are assigned to the CN1-10 and CN1-35 pins by default. When connecting a manual pulse generator, change them with [Pr. PD44] and [Pr. PD46]. Refer to section 9.1 for details of the manual pulse generator.
 17. Supply + of 24 DC V to OPC (Power input for open-collector sink interface) when input devices are assigned to the CN1-10 pin and the CN1-35 pin. They cannot be used with source input interface. For the positioning mode, input devices (DI2 and DI3) are assigned by default.

2. SIGNALS AND WIRING

(2) Program method

POINT
<ul style="list-style-type: none"> Assign the following output devices to CN1-22, CN1-23, and CN1-25 pins with [Pr. PD23], [Pr. PD24], and [Pr. PD26]. CN1-22: CPO (Rough match) CN1-23: ZP (Home position return completion) CN1-25: MEND (Travel completion)

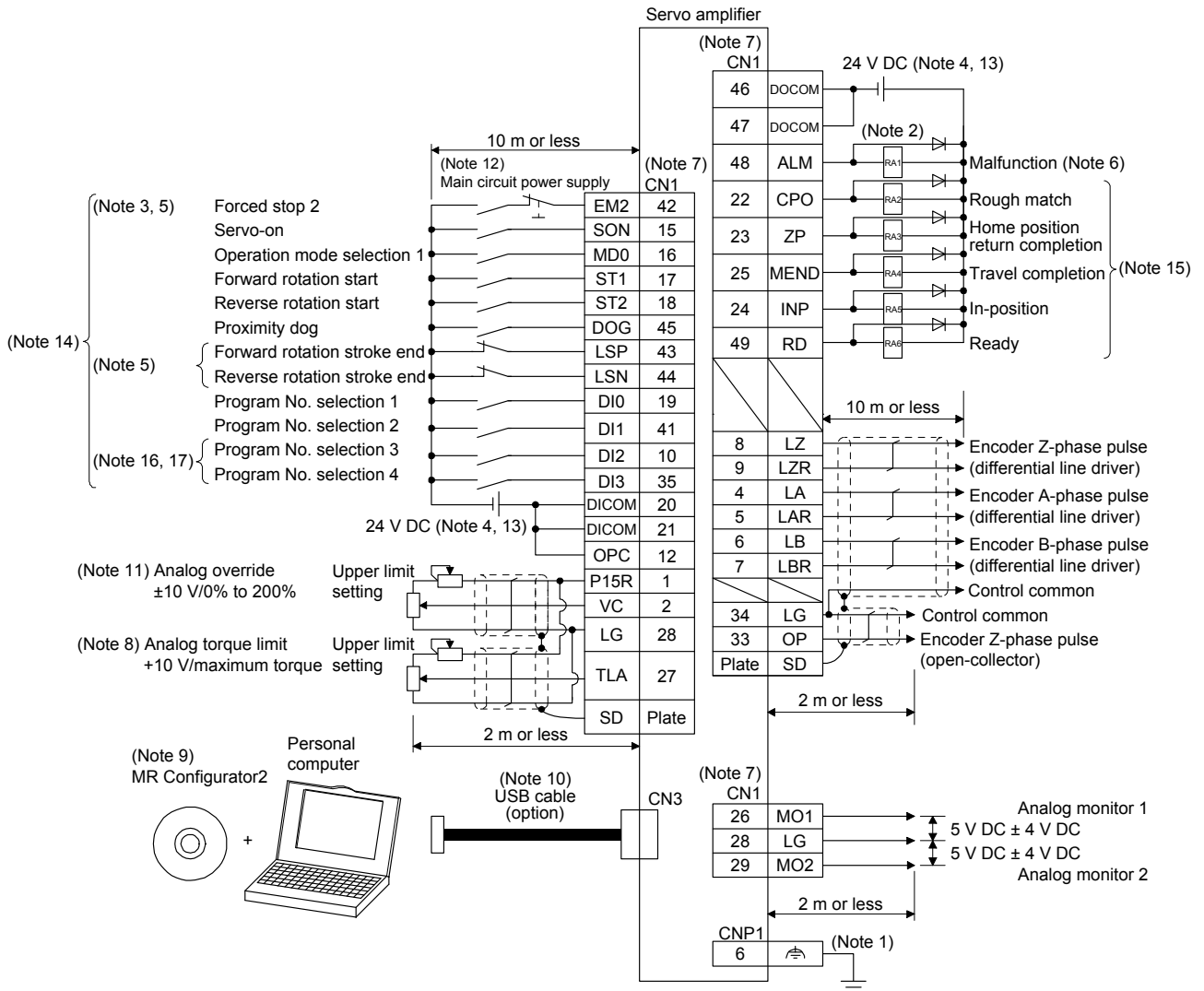

2. SIGNALS AND WIRING

- Note
1. To prevent an electric shock, always connect the CNP1 noiseless grounding terminal (≠marked) to the grounding terminal of the cabinet.
 2. Connect the diode in the correct direction. If it is connected reversely, the servo amplifier will malfunction and will not output signals, disabling EM2 (Forced stop 2) and other protective circuits.
 3. The forced stop switch (normally closed contact) must be installed.
 4. Supply 24 V DC \pm 10% to interfaces from outside. The total current capacity of these power supplies must be 300 mA or lower. 300 mA is the value applicable when all I/O signals are used. The current capacity can be decreased by reducing the number of I/O points. Refer to section 3.9.2 (1) of "MR-J4-_A_(-RJ) Servo Amplifier Instruction Manual" that gives the current value necessary for the interface. A 24 V DC power supply can be used for both input signal and output signal. For 24 V DC power for I/O signal, use power other than 24 V DC power of servo amplifier control circuit power supply.
 5. When starting operation, always turn on EM2 (Forced stop 2), LSP (Forward rotation stroke end) and LSN (Reverse rotation stroke end). (Normally closed contact)
 6. ALM (Malfunction) turns on in normal alarm-free condition. (Normally closed contact)
 7. The pins with the same signal name are connected in the servo amplifier.
 8. TLA will be available when TL (External torque limit selection) is enabled with [Pr. PD04], [Pr. PD06], [Pr. PD08], [Pr. PD10], [Pr. PD12], [Pr. PD14], [Pr. PD18], [Pr. PD20], [Pr. PD22], [Pr. PD44], and [Pr. PD46]. (Refer to section 3.6.1 (5) of "MR-J4-_A_(-RJ) Servo Amplifier Instruction Manual".)
 9. Use SW1DNC MRC2-_. (Refer to "MR-J4-_A_(-RJ) Servo Amplifier Instruction Manual" section 11.7.)
 10. The USB communication function and RS-422 communication function are mutually exclusive. They cannot be used together.
 11. Use an external power supply when inputting a negative voltage.
 12. Configure a circuit to turn off EM2 when the main circuit power is turned off to prevent an unexpected restart of the servo amplifier.
 13. This diagram shows sink I/O interface.
 14. The devices can be changed with [Pr. PD04], [Pr. PD06], [Pr. PD08], [Pr. PD10], [Pr. PD12], [Pr. PD14], [Pr. PD18], [Pr. PD20], [Pr. PD22], [Pr. PD44], and [Pr. PD46].
 15. Recommended device assignments are shown. The device can be changed by [Pr. PD23] to [Pr. PD26], and [Pr. PD28].
 16. DI2 and DI3 are assigned to the CN1-10 and CN1-35 pins by default. When connecting a manual pulse generator, change them with [Pr. PD44] and [Pr. PD46]. Refer to section 9.1 for details of the manual pulse generator.
 17. Supply + of 24 DC V to OPC (Power input for open-collector sink interface) when input devices are assigned to the CN1-10 pin and the CN1-35 pin. They cannot be used with source input interface. For the positioning mode, input devices (DI2 and DI3) are assigned by default.

2. SIGNALS AND WIRING

(3) Indexer method

POINT
<ul style="list-style-type: none"> ● In the indexer method, assign the following input device to CN1-18 pin with [Pr. PD10]. CN1-18: MD1 (Operation mode selection 2) ● Assign the following output devices to CN1-22, CN1-23, and CN1-25 pins with [Pr. PD23], [Pr. PD24], and [Pr. PD26]. CN1-22: CPO (Rough match) CN1-23: ZP (Home position return completion) CN1-25: MEND (Travel completion)

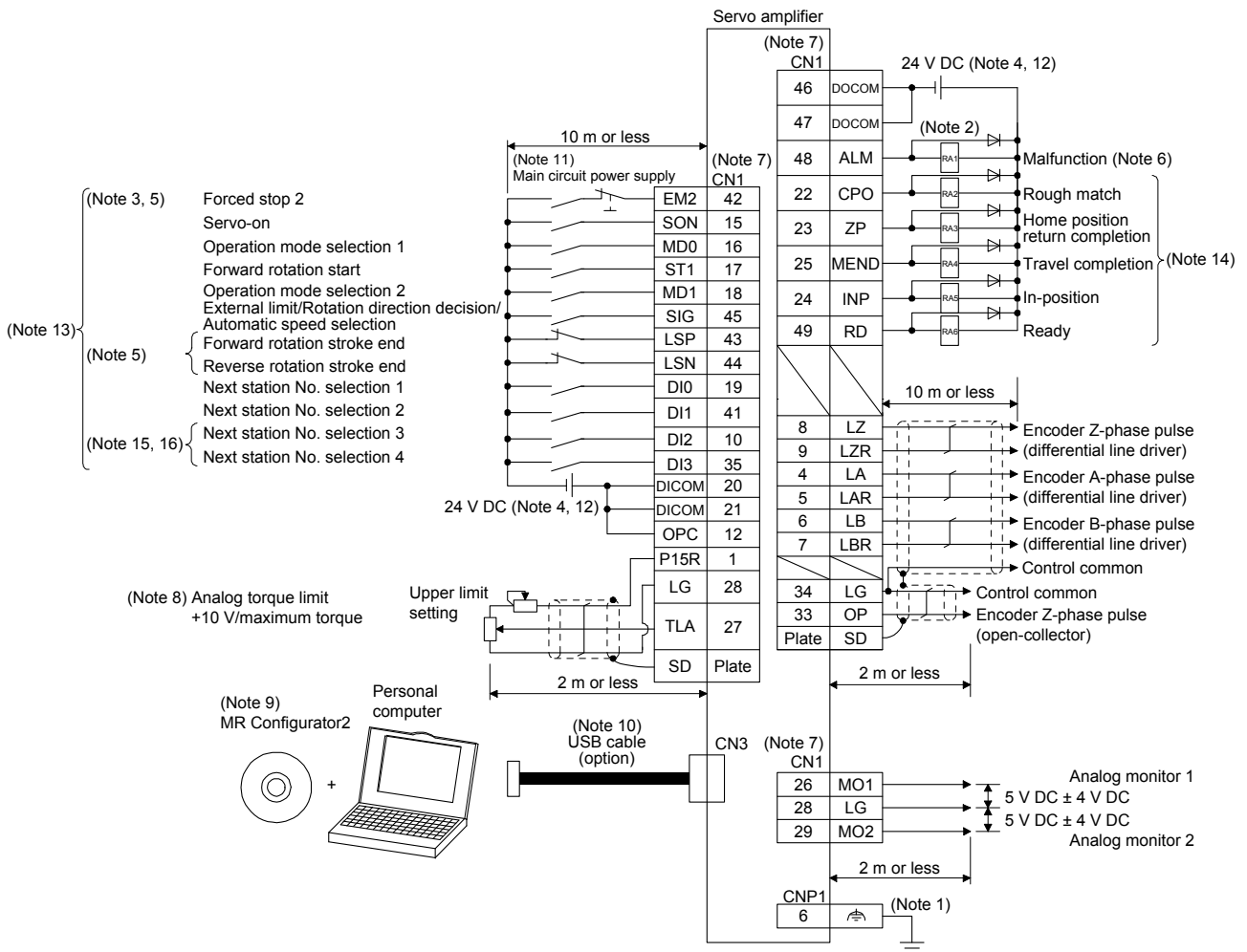

2. SIGNALS AND WIRING

- Note
1. To prevent an electric shock, always connect the CNP1 noiseless grounding terminal (≡marked) to the grounding terminal of the cabinet.
 2. Connect the diode in the correct direction. If it is connected reversely, the servo amplifier will malfunction and will not output signals, disabling EM2 (Forced stop 2) and other protective circuits.
 3. The forced stop switch (normally closed contact) must be installed.
 4. Supply 24 V DC \pm 10% to interfaces from outside. The total current capacity of these power supplies must be 300 mA or lower. 300 mA is the value applicable when all I/O signals are used. The current capacity can be decreased by reducing the number of I/O points. Refer to section 3.9.2 (1) of "MR-J4-_A_(-RJ) Servo Amplifier Instruction Manual" that gives the current value necessary for the interface. A 24 V DC power supply can be used for both input signal and output signal. For 24 V DC power for I/O signal, use power other than 24 V DC power of servo amplifier control circuit power supply.
 5. When starting operation, always turn on EM2 (Forced stop 2), LSP (Forward rotation stroke end) and LSN (Reverse rotation stroke end). (Normally closed contact)
 6. ALM (Malfunction) turns on in normal alarm-free condition. (Normally closed contact)
 7. The pins with the same signal name are connected in the servo amplifier.
 8. TLA will be available when TL (External torque limit selection) is enabled with [Pr. PD04], [Pr. PD06], [Pr. PD08], [Pr. PD10], [Pr. PD12], [Pr. PD14], [Pr. PD18], [Pr. PD20], [Pr. PD22], [Pr. PD44], and [Pr. PD46]. (Refer to section 3.6.1 (5) of "MR-J4-_A_(-RJ) Servo Amplifier Instruction Manual".)
 9. Use SW1DNC MRC2-_. (Refer to "MR-J4-_A_(-RJ) Servo Amplifier Instruction Manual" section 11.7.)
 10. The USB communication function and RS-422 communication function are mutually exclusive. They cannot be used together.
 11. Configure a circuit to turn off EM2 when the main circuit power is turned off to prevent an unexpected restart of the servo amplifier.
 12. This diagram shows sink I/O interface.
 13. The devices can be changed with [Pr. PD04], [Pr. PD06], [Pr. PD08], [Pr. PD10], [Pr. PD12], [Pr. PD14], [Pr. PD18], [Pr. PD20], [Pr. PD22], [Pr. PD44], and [Pr. PD46].
 14. Recommended device assignments are shown. The device can be changed by [Pr. PD23] to [Pr. PD26], and [Pr. PD28].
 15. DI2 and DI3 are assigned to the CN1-10 and CN1-35 pins by default. When connecting a manual pulse generator, change them with [Pr. PD44] and [Pr. PD46]. Refer to section 9.1 for details of the manual pulse generator.
 16. Supply + of 24 DC V to OPC (Power input for open-collector sink interface) when input devices are assigned to the CN1-10 pin and the CN1-35 pin. They cannot be used with source input interface. For the positioning mode, input devices (DI2 and DI3) are assigned by default.

2. SIGNALS AND WIRING

2.2 Connectors and pin assignment

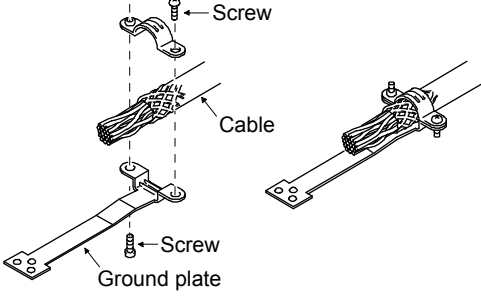
POINT
<ul style="list-style-type: none">● The pin assignment of the connectors is as viewed from the cable connector wiring section.● For the STO I/O signal connector (CN8), refer to chapter 13 of "MR-J4-_A_(-RJ) Servo Amplifier Instruction Manual".● For the CN1 connector, securely connect the external conductor of the shielded cable to the ground plate and fix it to the connector shell.  <ul style="list-style-type: none">● PP (CN1-10 pin) /NP (CN1-35 pin) and PP2 (CN1-37 pin) /NP2 (CN1-38 pin) are exclusive. They cannot be used together.

2. SIGNALS AND WIRING

(1) MR-J4-A-RJ 100 W or more

The servo amplifier front view shown is that of the MR-J4-20A-RJ or less. For other views of servo amplifiers, connector arrangements, and details, refer to chapter 9 of "MR-J4-A-(-RJ) Servo Amplifier Instruction Manual".

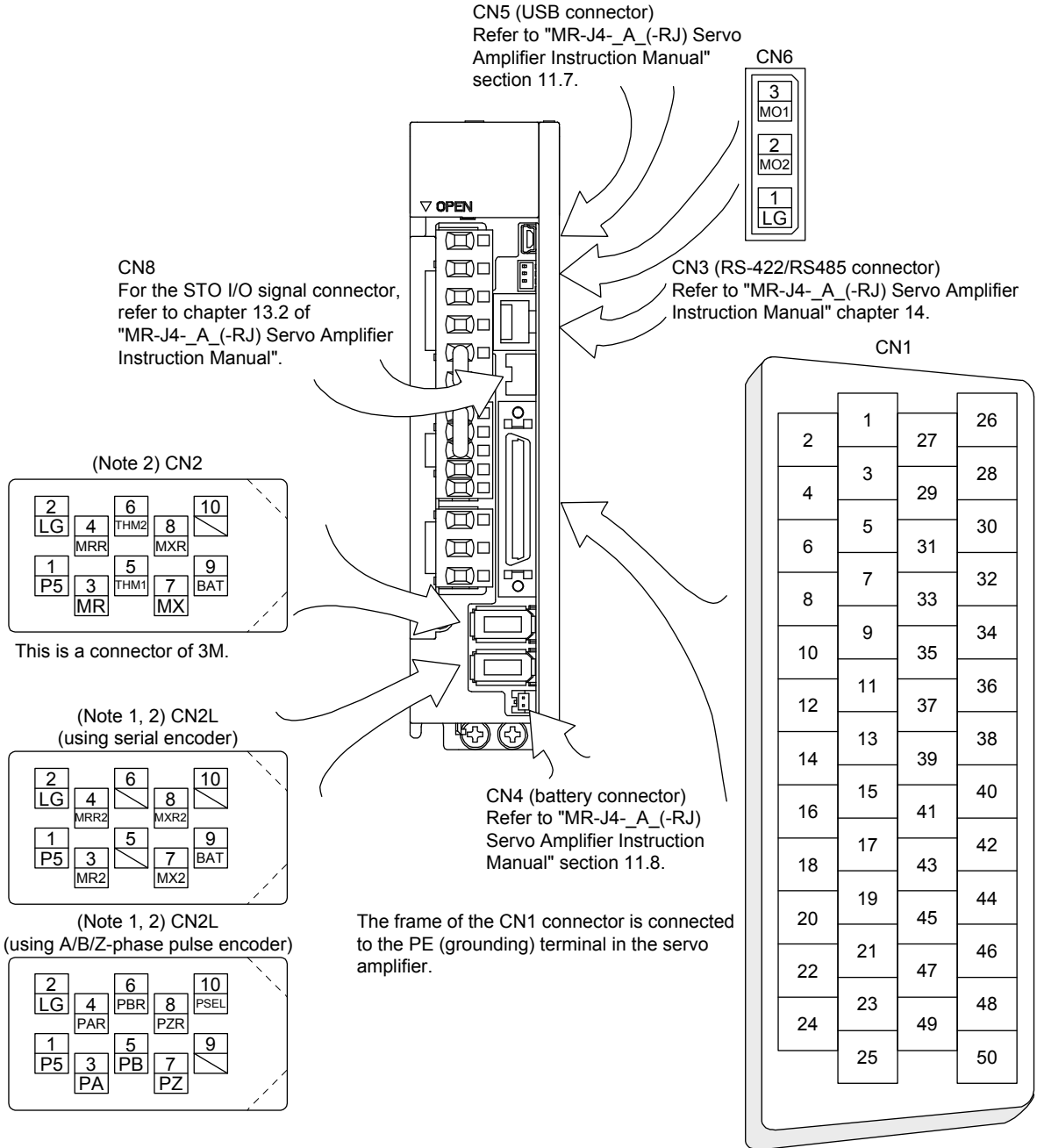

Note 1. This CN2L is a connector of 3M.

When using any other connector, refer to each servo motor instruction manual.

2. For the connection with external encoders, refer to table 1.1 of "MR-J4-A-(-RJ) Servo Amplifier Instruction Manual".

The device assignment of CN1 connector pins changes depending on the control mode. For the pins which are given parameters in the related parameter column, their devices will be changed using those parameters.

2. SIGNALS AND WIRING

Pin No.	(Note 1) I/O	(Note 2) I/O signals in control modes			Related parameter
		CP/BCD (Note 7)	CL	PS	
1		P15R	P15R	P15R	
2	I	VC	VC		
3		LG	LG	LG	
4	O	LA	LA	LA	
5	O	LAR	LAR	LAR	
6	O	LB	LB	LB	
7	O	LBR	LBR	LBR	
8	O	LZ	LZ	LZ	
9	O	LZR	LZR	LZR	
10	(Note 8) I	(Note 10)	(Note 10)	(Note 10)	PD44 (Note 9)
11	I	PG	PG	PG	
12		OPC	OPC	OPC	
13	O	(Note 4)	(Note 4)	(Note 4)	PD47
14	O	(Note 4)	(Note 4)	(Note 4)	PD47
15	I	SON	SON	SON	PD04
16	I	MD0	MD0	MD0	PD06
17	I	ST1	ST1	ST1	PD08
18	I	ST2	ST2	(Note 5) MD1	PD10
19	I	DI0	DI0	DI0	PD12
20		DICOM	DICOM	DICOM	
21		DICOM	DICOM	DICOM	
22	O	(Note 6) CPO	(Note 6) CPO	(Note 6) CPO	PD23
23	O	(Note 6) ZP	(Note 6) ZP	(Note 6) ZP	PD24
24 or less	O	INP	INP	INP	PD25
25	O	(Note 6) MEND	(Note 6) MEND	(Note 6) MEND	PD26
26					
27	I	(Note 3) TLA	(Note 3) TLA	(Note 3) TLA	
28		LG	LG	LG	
29					
30		LG	LG	LG	
31					
32					
33	O	OP	OP	OP	
34		LG	LG	LG	
35	(Note 8) I	(Note 10)	(Note 10)	(Note 10)	PD46 (Note 9)
36	I	NG	NG	NG	
37 (Note 12)	I	(Note 11)	(Note 11)	(Note 11)	PD44 (Note 9)
38 (Note 12)	I	(Note 11)	(Note 11)	(Note 11)	PD46 (Note 9)
39					
40					
41	I	DI1	DI1	DI1	PD14
42	I	EM2	EM2	EM2	
43	I	LSP	LSP	LSP	PD18
44	I	LSN	LSN	LSN	PD20
45	I	DOG	DOG	SIG	PD22
46		DOCOM	DOCOM	DOCOM	
47		DOCOM	DOCOM	DOCOM	
48	O	ALM	ALM	ALM	
49	O	RD	RD	RD	PD28
50					

2. SIGNALS AND WIRING

- Note
1. I: input signal, O: output signal
 2. CP: Positioning mode (point table method)
BCD: Positioning mode (point table method in the BCD input positioning operation)
This method is available only when the MR-D01 unit is connected. Refer to chapter 12 for details.
CL: Positioning mode (program method)
PS: Positioning mode (indexer method)
 3. TLA will be available when TL (External torque limit selection) is enabled with [Pr. PD04], [Pr. PD06], [Pr. PD08], [Pr. PD10], [Pr. PD12], [Pr. PD14], [Pr. PD18], [Pr. PD20], [Pr. PD22], [Pr. PD44], and [Pr. PD46].
 4. Assign any device with [Pr. PD47].
 5. In the indexer method, assign the following input device to CN1-18 pin with [Pr. PD10].
CN1-18: MD1 (Operation mode selection 2)
 6. Assign the following output devices to CN1-22, CN1-23, and CN1-25 pins with [Pr. PD23], [Pr. PD24], and [Pr. PD26].
CN1-22: CPO (Rough match)
CN1-23: ZP (Home position return completion)
CN1-25: MEND (Travel completion)
 7. For BCD input, refer to chapter 12.
 8. Supply + of 24 V DC to OPC (power input for open-collector sink interface) when using the CN1-10 pin and CN1-35 pin for DI.
 9. This parameter is available with servo amplifiers with software version B7 or later.
 10. This signal is used with sink interface. Input devices are not assigned by default. Assign the input devices with [Pr. PD44] and [Pr. PD46] as necessary. In addition, supply + of 24 DC V to the CN1-12 pin of OPC (Power input for open-collector sink interface). This is available with servo amplifiers with software version B7 or later.
 11. This signal is used with source interface. Input devices are not assigned by default. Assign the input devices with [Pr. PD44] and [Pr. PD46] as necessary.
 12. These pins are available with servo amplifiers having software version B7 or later, and manufactured in January 2015 or later.

2. SIGNALS AND WIRING

(2) MR-J4-03A6-RJ

For the views of servo amplifiers, connector arrangements, and details, refer to section 18.6 of "MR-J4-
A(-RJ) Servo Amplifier Instruction Manual".

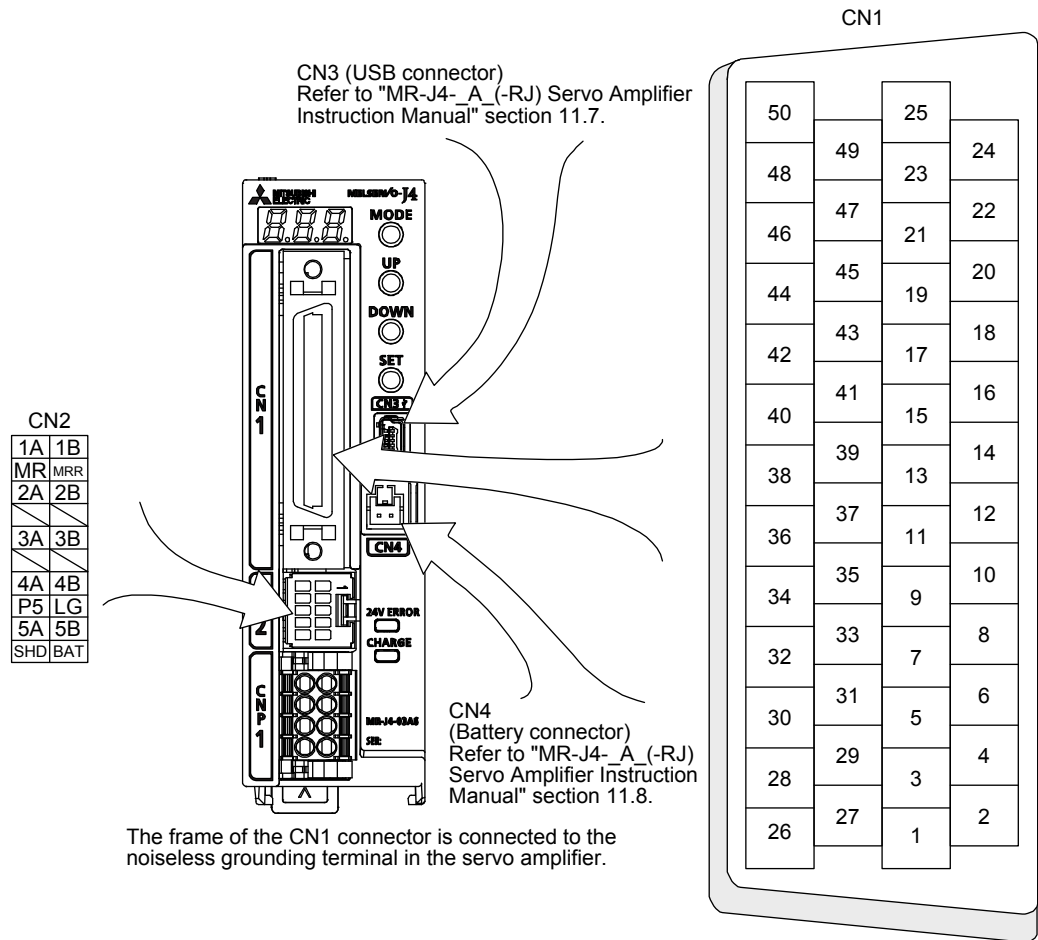

2. SIGNALS AND WIRING

The device assignment of the CN1 connector pins changes depending on the control mode. For the pins which are given parameters in the related parameter column, their devices can be changed using those parameters.

Pin No.	(Note 1) I/O	(Note 2) I/O signals in control modes			Related parameter
		CP	CL	PS	
1		P15R	P15R	P15R	
2	I	VC	VC		
3		LG	LG	LG	
4	O	LA	LA	LA	
5	O	LAR	LAR	LAR	
6	O	LB	LB	LB	
7	O	LBR	LBR	LBR	
8	O	LZ	LZ	LZ	
9	O	LZR	LZR	LZR	
10	(Note 6) I	(Note 8)	(Note 8)	(Note 8)	PD44 (Note 7)
11	I	PG	PG	PG	
12		OPC	OPC	OPC	
13	O	SDP	SDP	SDP	
14	O	SDN	SDN	SDN	
15	I	SON	SON	SON	PD04
16	I	MD0	MD0	MD0	PD06
17	I	ST1	ST1	ST1	PD08
18	I	ST2	ST2	(Note 4) MD1	PD10
19	I	DI0	DI0	DI0	PD12
20		DICOM	DICOM	DICOM	
21		DICOM	DICOM	DICOM	
22	O	(Note 5) CPO	(Note 5) CPO	(Note 5) CPO	PD23
23	O	(Note 5) ZP	(Note 5) ZP	(Note 5) ZP	PD24
24	O	INP	INP	INP	PD25
25	O	(Note 5) MEND	(Note 5) MEND	(Note 5) MEND	PD26
26	O	MO1	MO1	MO1	PC14
27	I	(Note 3) TLA	(Note 3) TLA	(Note 3) TLA	
28		LG	LG	LG	
29	O	MO2	MO2	MO2	PC15
30		LG	LG	LG	
31	I	TRE	TRE	TRE	
32					
33	O	OP	OP	OP	
34		LG	LG	LG	
35	(Note 6) I	(Note 8)	(Note 8)	(Note 8)	PD46 (Note 7)
36	I	NG	NG	NG	
37	I	(Note 9)	(Note 9)	(Note 9)	PD44 (Note 7)
38	I	(Note 9)	(Note 9)	(Note 9)	PD46 (Note 7)
39	I	RDP	RDP	RDP	
40	I	RDN	RDN	RDN	
41	I	DI1	DI1	DI1	PD14
42	I	EM2	EM2	EM2	
43	I	LSP	LSP	LSP	PD18
44	I	LSN	LSN	LSN	PD20
45	I	DOG	DOG	SIG	PD22
46		DOCOM	DOCOM	DOCOM	
47		DOCOM	DOCOM	DOCOM	
48	O	ALM	ALM	ALM	
49	O	RD	RD	RD	PD28
50					

2. SIGNALS AND WIRING

- Note
1. I: input signal, O: output signal
 2. CP: Positioning mode (point table method)
CL: Positioning mode (program method)
PS: Positioning mode (indexer method)
 3. TLA will be available when TL (External torque limit selection) is enabled with [Pr. PD04], [Pr. PD06], [Pr. PD08], [Pr. PD10], [Pr. PD12], [Pr. PD14], [Pr. PD18], [Pr. PD20], [Pr. PD22], [Pr. PD44], and [Pr. PD46].
 4. In the indexer method, assign the following input device to CN1-18 pin with [Pr. PD10].
CN1-18: MD1 (Operation mode selection 2)
 5. Assign the following output devices to CN1-22, CN1-23, and CN1-25 pins with [Pr. PD23], [Pr. PD24], and [Pr. PD26].
CN1-22: CPO (Rough match)
CN1-23: ZP (Home position return completion)
CN1-25: MEND (Travel completion)
 6. Supply + of 24 V DC to OPC (power input for open-collector sink interface) when using the CN1-10 and CN1-35 pins for DI.
 7. This is available with servo amplifiers with software version B7 or later.
 8. This is used with sink interface. Input devices are not assigned by default. Assign the input devices with [Pr. PD44] and [Pr. PD46] as necessary. In addition, supply + of 24 DC V to the CN1-12 pin of OPC (Power input for open-collector sink interface).
 9. This is used with source interface. Input devices are not assigned by default. Assign the input devices with [Pr. PD44] and [Pr. PD46] as necessary.

2. SIGNALS AND WIRING

2.3 Signal (device) explanations

The pin numbers in the connector pin No. column are those in the initial status.

For the I/O interfaces (symbols in I/O division column in the table), refer to section 3.9.2 of "MR-J4-_A_(-RJ) Servo Amplifier Instruction Manual". The symbols in the control mode field of the table show the followings.

CP: Positioning mode (point table method)

BCD: Positioning mode (point table method in the BCD input positioning operation)

This method is available only when the MR-D01 unit is connected. Refer to chapter 12 for details.

CL: Positioning mode (program method)

PS: Positioning mode (indexer method)

"○" and "△" of the table show the followings.

○: Usable device by default.

△: Usable device by setting the following parameters.

[Pr. PD04], [Pr. PD06], [Pr. PD08], [Pr. PD10], [Pr. PD12], [Pr. PD14], [Pr. PD18], [Pr. PD20], [Pr. PD22] to [Pr. PD26], [Pr. PD28], [Pr. PD44], [Pr. PD46], and [Pr. PD47]

(1) I/O device

(a) Input device

Device	Symbol	Connector pin No.	Function and application	I/O division	Control mode																
					CP/BCD	CL	PS														
Forced stop 2	EM2	CN1-42	<p>Turn off EM2 (open between commons) to decelerate the servo motor to a stop with commands.</p> <p>Turn EM2 on (short between commons) in the forced stop state to reset that state.</p> <p>The following shows the setting of [Pr. PA04].</p> <table border="1" style="margin-left: auto; margin-right: auto;"> <thead> <tr> <th rowspan="2">[Pr. PA04] setting</th> <th rowspan="2">EM2/EM1</th> <th colspan="2">Deceleration method</th> </tr> <tr> <th>EM2 or EM1 is off</th> <th>Alarm occurred</th> </tr> </thead> <tbody> <tr> <td>0 _ _ _</td> <td>EM1</td> <td>MBR (Electromagnetic brake interlock) turns off without the forced stop deceleration.</td> <td>MBR (Electromagnetic brake interlock) turns off without the forced stop deceleration.</td> </tr> <tr> <td>2 _ _ _</td> <td>EM2</td> <td>MBR (Electromagnetic brake interlock) turns off after the forced stop deceleration.</td> <td>MBR (Electromagnetic brake interlock) turns off after the forced stop deceleration.</td> </tr> </tbody> </table> <p>EM2 and EM1 are mutually exclusive.</p>	[Pr. PA04] setting	EM2/EM1	Deceleration method		EM2 or EM1 is off	Alarm occurred	0 _ _ _	EM1	MBR (Electromagnetic brake interlock) turns off without the forced stop deceleration.	MBR (Electromagnetic brake interlock) turns off without the forced stop deceleration.	2 _ _ _	EM2	MBR (Electromagnetic brake interlock) turns off after the forced stop deceleration.	MBR (Electromagnetic brake interlock) turns off after the forced stop deceleration.	DI-1	○	○	○
[Pr. PA04] setting	EM2/EM1	Deceleration method																			
		EM2 or EM1 is off	Alarm occurred																		
0 _ _ _	EM1	MBR (Electromagnetic brake interlock) turns off without the forced stop deceleration.	MBR (Electromagnetic brake interlock) turns off without the forced stop deceleration.																		
2 _ _ _	EM2	MBR (Electromagnetic brake interlock) turns off after the forced stop deceleration.	MBR (Electromagnetic brake interlock) turns off after the forced stop deceleration.																		
Forced stop 1	EM1	(CN1-42)	<p>When using EM1, set [Pr. PA04] to "0 _ _ _" to enable EM1.</p> <p>When EM1 is turned off (open between commons), the base circuit shuts off, and the dynamic brake operates to decelerate the servo motor to a stop.</p> <p>Turn EM1 on (short between commons) in the forced stop state to reset that state.</p>	DI-1	△	△	△														
Servo-on	SON	CN1-15	<p>Turn SON on to power on the base circuit and make the servo amplifier ready to operate. (servo-on status)</p> <p>Turn it off to shut off the base circuit and coast the servo motor.</p> <p>Set "_ _ _ 4" in [Pr. PD01] to switch this signal on (keep terminals connected) automatically in the servo amplifier.</p>	DI-1	○	○	○														
Reset	RES		<p>Turn on RES for more than 50 ms to reset the alarm.</p> <p>Some alarms cannot be deactivated by RES (Reset). Refer to chapter 8.</p> <p>Turning RES on in an alarm-free status shuts off the base circuit. The base circuit is not shut off when "_ _ 1 _" is set in [Pr. PD30].</p> <p>This device is not designed to make a stop. Do not turn it on during operation.</p>	DI-1	△	△	△														

2. SIGNALS AND WIRING

Device	Symbol	Connector pin No.	Function and application	I/O division	Control mode																																							
					CP/BCD	CL	CS																																					
Forward rotation stroke end	LSP	CN1-43	To start operation, turn on LSP and LSN. Turn it off to bring the motor to a sudden stop and make it servo-locked. Setting [Pr. PD30] to "___ 1" will enable "Slow stop (home position erased)".	DI-1	○	○	○																																					
Reverse rotation stroke end	LSN	CN1-44	<table border="1" data-bbox="588 528 1078 808"> <thead> <tr> <th colspan="2">(Note) Input device</th> <th colspan="2">Operation</th> </tr> <tr> <th>LSP</th> <th>LSN</th> <th>CCW direction Positive direction</th> <th>CW direction Negative direction</th> </tr> </thead> <tbody> <tr> <td>1</td> <td>1</td> <td>○</td> <td>○</td> </tr> <tr> <td>0</td> <td>1</td> <td></td> <td>○</td> </tr> <tr> <td>1</td> <td>0</td> <td>○</td> <td></td> </tr> <tr> <td>0</td> <td>0</td> <td></td> <td></td> </tr> </tbody> </table> <p>Note. 0: Off 1: On</p> <p>The stop method can be changed with [Pr. PD30]. Set [Pr. PD01] as indicated below to switch on the signals (keep terminals connected) automatically in the servo amplifier.</p> <table border="1" data-bbox="588 992 1078 1236"> <thead> <tr> <th rowspan="2">[Pr. PD01]</th> <th colspan="2">Status</th> </tr> <tr> <th>LSP</th> <th>LSN</th> </tr> </thead> <tbody> <tr> <td>_ 4 _ _</td> <td>Automatic on</td> <td></td> </tr> <tr> <td>_ 8 _ _</td> <td></td> <td>Automatic on</td> </tr> <tr> <td>_ C _ _</td> <td>Automatic on</td> <td>Automatic on</td> </tr> </tbody> </table> <p>When LSP or LSN is turned off, [AL. 99 Stroke limit warning] occurs, and WNG (Warning) turns on. When using WNG, enable it by setting [Pr. PD23] to [Pr. PD26], [Pr. PD28], and [Pr. PD47]. However, [Pr. PD47] is not available with MR-J4-03A6-RJ servo amplifiers.</p>	(Note) Input device		Operation		LSP	LSN	CCW direction Positive direction	CW direction Negative direction	1	1	○	○	0	1		○	1	0	○		0	0			[Pr. PD01]	Status		LSP	LSN	_ 4 _ _	Automatic on		_ 8 _ _		Automatic on	_ C _ _	Automatic on	Automatic on			
(Note) Input device		Operation																																										
LSP	LSN	CCW direction Positive direction	CW direction Negative direction																																									
1	1	○	○																																									
0	1		○																																									
1	0	○																																										
0	0																																											
[Pr. PD01]	Status																																											
	LSP	LSN																																										
_ 4 _ _	Automatic on																																											
_ 8 _ _		Automatic on																																										
_ C _ _	Automatic on	Automatic on																																										
External torque limit selection	TL		Turning off TL will enable [Pr. PA11 Forward torque limit] and [Pr. PA12 Reverse torque limit], and turning on it will enable TLA (Analog torque limit). For details, refer to section 3.6.1 (5) of "MR-J4- _A_(-RJ) Servo Amplifier Instruction Manual". For the indexer method, [Pr. PC35 Internal torque limit 2] will be enabled automatically depending on operation status. Refer to each timing chart in section 6.2 and section 6.4.5.	DI-1	△	△	△																																					
Internal torque limit selection	TL1		To select [Pr. PC35 Internal torque limit 2/internal thrust limit 2], enable TL1 with [Pr. PD04], [Pr. PD06], [Pr. PD08], [Pr. PD10], [Pr. PD12], [Pr. PD14], [Pr. PD18], [Pr. PD20], [Pr. PD22], [Pr. PD44], and [Pr. PD46]. For details, refer to section 3.6.1 (5) of "MR-J4- _A_(-RJ) Servo Amplifier Instruction Manual". For the indexer method, [Pr. PC35 Internal torque limit 2] will be enabled automatically depending on operation status. Refer to each timing chart in section 6.2 and section 6.4.5.	DI-1	△	△	△																																					

2. SIGNALS AND WIRING

Device	Symbol	Connector pin No.	Function and application	I/O division	Control mode		
					CP/BCD	CL	CS
Operation mode selection 1	MD0	CN1-16	Point table method/program method Turning on MD0 will be automatic operation mode, off will be manual operation mode. Changing an operation mode during operation will clear the command remaining distance and the motor will decelerate to stop. MD1 cannot be used.	DI-1	○	○	○
Operation mode selection 2	MD1		Indexer method Select an operation mode with combinations of MD0 and MD1. Refer to the following table for combinations. Changing an operation mode during operation will clear the command remaining distance and the motor will decelerate to stop.	DI-1			△

Device (Note)		Operation mode
MD1	MD0	
0	0	Home position return mode
0	1	Manual operation mode
1	0	Automatic operation mode 1 (rotation direction specifying indexer)
1	1	Automatic operation mode 2 (shortest rotating indexer)

Note. 0: Off
1: On

2. SIGNALS AND WIRING

Device	Symbol	Connector pin No.	Function and application	I/O division	Control mode		
					CP/BCD	CL	PS
Forward rotation start	ST1	CN1-17	<p>Point table method</p> <p>1. Absolute value command method Turning on ST1 during automatic operation will execute one positioning based on position data set in point tables. Turning on ST1 during home position return will also start home position return. Turning on ST1 during JOG operation will rotate the motor in the forward rotation direction while it is on. The forward rotation means address increasing direction. Turning on both ST1 and ST2 during JOG operation will stop the servo motor.</p> <p>2. Incremental value command method Turning on ST1 during automatic operation will execute one positioning in the forward rotation direction based on position data set in point tables. Turning on ST1 during home position return will also start home position return. Turning on ST1 during JOG operation will rotate the motor in the forward rotation direction while it is on. The forward rotation means address increasing direction. Turning on both ST1 and ST2 during JOG operation will stop the servo motor.</p>	DI-1	○		
			<p>Program method</p> <p>1. Automatic operation mode Turning on ST1 will execute a program operation selected with DI0 to DI7. The forward rotation means address increasing direction. Turning on both ST1 and ST2 during manual operation mode will stop the servo motor.</p> <p>2. Manual operation mode Turning on ST1 will rotate the motor in the forward rotation direction while it is on. The forward rotation means address increasing direction. Turning on both ST1 and ST2 during manual operation mode will stop the servo motor.</p>			○	
			<p>Indexer method</p> <p>1. Automatic operation mode 1 or automatic operation mode 2 Turning on ST1 will execute one positioning to the specified station No.</p> <p>2. Manual operation mode Turning on ST1 with the station JOG operation will rotate the motor in the specified direction with SIG only while it is on. Turning off ST1 will execute a positioning to a station which can be decelerated to a stop. Turning on ST1 with JOG operation will rotate the motor in the direction specified with SIG only while it is on. Turning off will decelerate the motor to a stop regardless of stations.</p> <p>3. Home position return mode Turning on ST1 will also start home position return.</p>				○
Reverse rotation start	ST2	CN1-18	<p>Point table method</p> <p>Use this device with the incremental value command method. Turning on ST2 during automatic operation will execute one positioning in the reverse rotation direction based on position data set in point tables. Turning on ST2 during JOG operation will rotate the motor in the reverse rotation direction while it is on. Turning on both ST1 and ST2 will stop the servo motor. Turning on ST2 during in the home position return mode will execute an automatic positioning to the home position. The reverse rotation means address decreasing direction. Turning on both ST1 and ST2 during JOG operation will stop the servo motor.</p>	DI-1	○		
			<p>Program method</p> <p>Turning on ST2 with JOG operation in the manual operation mode will rotate the motor in the reverse rotation direction while it is on. Turning on both ST1 and ST2 will stop the servo motor. The reverse rotation means address decreasing direction. Turning on both ST1 and ST2 during manual operation mode will stop the servo motor. ST2 will be disabled in the automatic operation mode.</p>			○	
			<p>Indexer method</p> <p>This device is not used.</p>				

2. SIGNALS AND WIRING

Device	Symbol	Connector pin No.	Function and application	I/O division	Control mode																			
					CP/BCD	CU	CS																	
Temporary stop/restart	TSTP		Turning on TSTP during automatic operation will temporarily stop the motor. Turning on TSTP again will restart. Turning on ST1 (Forward rotation start)/ST2 (Reverse rotation start) during a temporary stop will not rotate the motor. Changing the automatic operation mode to manual operation mode during a temporary stop will erase a travel remaining distance. The temporary stop/restart input will not function during home position return/JOG operation.	DI-1	△	△																		
Proximity dog	DOG	CN1-45	Turning off DOG will detect a proximity dog. The polarity for dog detection can be changed with [Pr. PT29]. <table border="1" style="margin: 10px auto;"> <thead> <tr> <th>[Pr. PT29]</th> <th>Polarity for proximity dog detection</th> </tr> </thead> <tbody> <tr> <td>___ 0</td> <td>Detection with off</td> </tr> <tr> <td>___ 1</td> <td>Detection with on</td> </tr> </tbody> </table>	[Pr. PT29]	Polarity for proximity dog detection	___ 0	Detection with off	___ 1	Detection with on	DI-1	○	○												
[Pr. PT29]	Polarity for proximity dog detection																							
___ 0	Detection with off																							
___ 1	Detection with on																							
External limit/ Rotation direction decision/ Automatic speed selection	SIG	CN1-45	The function varies depending on the operation mode. <ol style="list-style-type: none"> Home position return mode (MD1 = 0, MD0 = 0) You can use SIG as an input device of external limit. This operation mode is enabled when the home position return type of the torque limit changing dog type is selected. Manual operation mode (MD1 = 0, MD0 = 1) You can use this as an input device for specifying a rotation direction of the servo motor. The rotation direction varies depending on the setting of [Pr. PA14 Rotation direction selection]. (Refer to section 2.1.) Automatic operation mode 1 (rotation direction specifying indexer) (MD1 = 1, MD0 = 0) You can use this as an input device for specifying a rotation direction of the servo motor. The rotation direction varies depending on the setting of [Pr. PA14 Rotation direction selection]. (Refer to section 2.1.) Automatic operation mode 2 (shortest rotating indexer) (MD1 = 1, MD0 = 1) You can use SIG as an input device for selecting a speed of the servo motor. <p>Table 2.1 Rotation direction selection</p> <table border="1" style="margin: 10px auto;"> <thead> <tr> <th>[Pr. PA14]</th> <th>SIG (Note)</th> <th>Servo motor rotation direction</th> </tr> </thead> <tbody> <tr> <td>0</td> <td>0</td> <td>CCW direction</td> </tr> <tr> <td>0</td> <td>1</td> <td>CW direction</td> </tr> <tr> <td>1</td> <td>0</td> <td>CW direction</td> </tr> <tr> <td>1</td> <td>1</td> <td>CCW direction</td> </tr> </tbody> </table> <p>Note. 0: Off 1: On</p>	[Pr. PA14]	SIG (Note)	Servo motor rotation direction	0	0	CCW direction	0	1	CW direction	1	0	CW direction	1	1	CCW direction	DI-1			○		
[Pr. PA14]	SIG (Note)	Servo motor rotation direction																						
0	0	CCW direction																						
0	1	CW direction																						
1	0	CW direction																						
1	1	CCW direction																						
Manual pulse generator multiplication 1	TP0		Select a multiplication of the manual pulse generator. When a multiplication is not selected, the setting of [Pr. PT03] will be enabled.	DI-1	△	△																		
Manual pulse generator multiplication 2	TP1		<table border="1" style="margin: 10px auto;"> <thead> <tr> <th colspan="2">Device (Note)</th> <th rowspan="2">Manual pulse generator multiplication</th> </tr> <tr> <th>TP1</th> <th>TP0</th> </tr> </thead> <tbody> <tr> <td>0</td> <td>0</td> <td>[Pr. PT03] setting</td> </tr> <tr> <td>0</td> <td>1</td> <td>× 1</td> </tr> <tr> <td>1</td> <td>0</td> <td>× 10</td> </tr> <tr> <td>1</td> <td>1</td> <td>× 100</td> </tr> </tbody> </table> <p>Note. 0: Off 1: On</p>	Device (Note)		Manual pulse generator multiplication	TP1	TP0	0	0	[Pr. PT03] setting	0	1	× 1	1	0	× 10	1	1	× 100	DI-1	△	△	
Device (Note)		Manual pulse generator multiplication																						
TP1	TP0																							
0	0	[Pr. PT03] setting																						
0	1	× 1																						
1	0	× 10																						
1	1	× 100																						

2. SIGNALS AND WIRING

Device	Symbol	Connector pin No.	Function and application	I/O division	Control mode																																																																																																					
					CP/BCD	CL	PS																																																																																																			
Analog override selection	OVR		Turning on OVR will enable VC (Analog override).	DI-1	△	△																																																																																																				
Teach	TCH		Use this for teaching. Turning on TCH in the point table method will rewrite a position data of the selected point table No. to the current position.	DI-1	△																																																																																																					
Program input 1	PI1		Turning on PI1 will restart a step which was suspended with the SYNC (1) command during programming.	DI-1		△																																																																																																				
Program input 2	PI2		Turning on PI2 will restart a step which was suspended with the SYNC (2) command during programming.	DI-1		△																																																																																																				
Program input 3	PI3		Turning on PI3 will restart a step which was suspended with the SYNC (3) command during programming.	DI-1		△																																																																																																				
Current position latch input	LPS		Turning on LPS during execution of the LPOS command will latch a current position with its rising edge. The latched current position can be read with communication commands.	DI-1		△																																																																																																				
Point table No./program No. selection 1	DI0	CN1-19	Point table method Select point tables and home position return mode with DI0 to DI7.	DI-1	○	○																																																																																																				
Point table No./program No. selection 2	DI1	CN1-41			<table border="1"> <thead> <tr> <th colspan="8">Device (Note)</th> <th rowspan="2">Selection contents</th> </tr> <tr> <th>DI7</th> <th>DI6</th> <th>DI5</th> <th>DI4</th> <th>DI3</th> <th>DI2</th> <th>DI1</th> <th>DI0</th> </tr> </thead> <tbody> <tr> <td>0</td> <td>0</td> <td>0</td> <td>0</td> <td>0</td> <td>0</td> <td>0</td> <td>0</td> <td>Home position return mode</td> </tr> <tr> <td>0</td> <td>0</td> <td>0</td> <td>0</td> <td>0</td> <td>0</td> <td>0</td> <td>1</td> <td>Point table No. 1</td> </tr> <tr> <td>0</td> <td>0</td> <td>0</td> <td>0</td> <td>0</td> <td>0</td> <td>1</td> <td>0</td> <td>Point table No. 2</td> </tr> <tr> <td>0</td> <td>0</td> <td>0</td> <td>0</td> <td>0</td> <td>0</td> <td>1</td> <td>1</td> <td>Point table No. 3</td> </tr> <tr> <td>.</td> <td>.</td> <td>.</td> <td>.</td> <td>.</td> <td>.</td> <td>.</td> <td>.</td> <td>.</td> </tr> <tr> <td>.</td> <td>.</td> <td>.</td> <td>.</td> <td>.</td> <td>.</td> <td>.</td> <td>.</td> <td>.</td> </tr> <tr> <td>.</td> <td>.</td> <td>.</td> <td>.</td> <td>.</td> <td>.</td> <td>.</td> <td>.</td> <td>.</td> </tr> <tr> <td>1</td> <td>1</td> <td>1</td> <td>1</td> <td>1</td> <td>1</td> <td>1</td> <td>0</td> <td>Point table No. 254</td> </tr> <tr> <td>1</td> <td>1</td> <td>1</td> <td>1</td> <td>1</td> <td>1</td> <td>1</td> <td>1</td> <td>Point table No. 255</td> </tr> </tbody> </table>	Device (Note)								Selection contents	DI7	DI6	DI5	DI4	DI3	DI2	DI1	DI0	0	0	0	0	0	0	0	0	Home position return mode	0	0	0	0	0	0	0	1	Point table No. 1	0	0	0	0	0	0	1	0	Point table No. 2	0	0	0	0	0	0	1	1	Point table No. 3	1	1	1	1	1	1	1	0	Point table No. 254	1	1	1	1	1	1	1	1	Point table No. 255	○	○	
Device (Note)								Selection contents																																																																																																		
DI7	DI6	DI5			DI4	DI3	DI2		DI1	DI0																																																																																																
0	0	0			0	0	0	0	0	Home position return mode																																																																																																
0	0	0			0	0	0	0	1	Point table No. 1																																																																																																
0	0	0			0	0	0	1	0	Point table No. 2																																																																																																
0	0	0			0	0	0	1	1	Point table No. 3																																																																																																
.																																																																																																		
.																																																																																																		
.																																																																																																		
1	1	1	1	1	1	1	0	Point table No. 254																																																																																																		
1	1	1	1	1	1	1	1	Point table No. 255																																																																																																		
Point table No./program No. selection 3	DI2	CN1-10		○	○																																																																																																					
Point table No./program No. selection 4	DI3	CN1-35		○	○																																																																																																					
Point table No./program No. selection 5	DI4			△	△																																																																																																					
Point table No./program No. selection 6	DI5			△	△																																																																																																					
Point table No./program No. selection 7	DI6			△	△																																																																																																					
Point table No./program No. selection 8	DI7		Program method Select program Nos. with DI0 to DI7.	△	△																																																																																																					
			<table border="1"> <thead> <tr> <th colspan="8">Device (Note)</th> <th rowspan="2">Selection contents</th> </tr> <tr> <th>DI7</th> <th>DI6</th> <th>DI5</th> <th>DI4</th> <th>DI3</th> <th>DI2</th> <th>DI1</th> <th>DI0</th> </tr> </thead> <tbody> <tr> <td>0</td> <td>0</td> <td>0</td> <td>0</td> <td>0</td> <td>0</td> <td>0</td> <td>0</td> <td>Program No. 1</td> </tr> <tr> <td>0</td> <td>0</td> <td>0</td> <td>0</td> <td>0</td> <td>0</td> <td>0</td> <td>1</td> <td>Program No. 2</td> </tr> <tr> <td>0</td> <td>0</td> <td>0</td> <td>0</td> <td>0</td> <td>0</td> <td>1</td> <td>0</td> <td>Program No. 3</td> </tr> <tr> <td>0</td> <td>0</td> <td>0</td> <td>0</td> <td>0</td> <td>0</td> <td>1</td> <td>1</td> <td>Program No. 4</td> </tr> <tr> <td>.</td> <td>.</td> <td>.</td> <td>.</td> <td>.</td> <td>.</td> <td>.</td> <td>.</td> <td>.</td> </tr> <tr> <td>.</td> <td>.</td> <td>.</td> <td>.</td> <td>.</td> <td>.</td> <td>.</td> <td>.</td> <td>.</td> </tr> <tr> <td>.</td> <td>.</td> <td>.</td> <td>.</td> <td>.</td> <td>.</td> <td>.</td> <td>.</td> <td>.</td> </tr> <tr> <td>1</td> <td>1</td> <td>1</td> <td>1</td> <td>1</td> <td>1</td> <td>1</td> <td>0</td> <td>Program No. 255</td> </tr> <tr> <td>1</td> <td>1</td> <td>1</td> <td>1</td> <td>1</td> <td>1</td> <td>1</td> <td>1</td> <td>Program No. 256</td> </tr> </tbody> </table>	Device (Note)								Selection contents	DI7	DI6	DI5	DI4	DI3	DI2	DI1	DI0	0	0	0	0	0	0	0	0	Program No. 1	0	0	0	0	0	0	0	1	Program No. 2	0	0	0	0	0	0	1	0	Program No. 3	0	0	0	0	0	0	1	1	Program No. 4	1	1	1	1	1	1	1	0	Program No. 255	1	1	1	1	1	1	1	1	Program No. 256					
Device (Note)								Selection contents																																																																																																		
DI7	DI6	DI5	DI4	DI3	DI2	DI1	DI0																																																																																																			
0	0	0	0	0	0	0	0	Program No. 1																																																																																																		
0	0	0	0	0	0	0	1	Program No. 2																																																																																																		
0	0	0	0	0	0	1	0	Program No. 3																																																																																																		
0	0	0	0	0	0	1	1	Program No. 4																																																																																																		
.																																																																																																		
.																																																																																																		
.																																																																																																		
1	1	1	1	1	1	1	0	Program No. 255																																																																																																		
1	1	1	1	1	1	1	1	Program No. 256																																																																																																		

2. SIGNALS AND WIRING

Device	Symbol	Connector pin No.	Function and application	I/O division	Control mode																																																																																											
					CP/BCD	CL	PS																																																																																									
Next station No. selection 1	DI0	CN1-19	Indexer method Select next station Nos. with DI0 to DI7. A setting value at ST1 on will be enabled.	DI-1	/	/	○																																																																																									
Next station No. selection 2	DI1	CN1-41	<table border="1"> <thead> <tr> <th colspan="8">Device (Note 1)</th> <th rowspan="2">Selection contents</th> </tr> <tr> <th>DI7</th> <th>DI6</th> <th>DI5</th> <th>DI4</th> <th>DI3</th> <th>DI2</th> <th>DI1</th> <th>DI0</th> </tr> </thead> <tbody> <tr> <td>0</td> <td>0</td> <td>0</td> <td>0</td> <td>0</td> <td>0</td> <td>0</td> <td>0</td> <td>Next station No. 0</td> </tr> <tr> <td>0</td> <td>0</td> <td>0</td> <td>0</td> <td>0</td> <td>0</td> <td>0</td> <td>1</td> <td>Next station No. 1</td> </tr> <tr> <td>0</td> <td>0</td> <td>0</td> <td>0</td> <td>0</td> <td>0</td> <td>1</td> <td>0</td> <td>Next station No. 2</td> </tr> <tr> <td>0</td> <td>0</td> <td>0</td> <td>0</td> <td>0</td> <td>0</td> <td>1</td> <td>1</td> <td>Next station No. 3</td> </tr> <tr> <td>.</td> <td>.</td> <td>.</td> <td>.</td> <td>.</td> <td>.</td> <td>.</td> <td>.</td> <td>.</td> </tr> <tr> <td>.</td> <td>.</td> <td>.</td> <td>.</td> <td>.</td> <td>.</td> <td>.</td> <td>.</td> <td>.</td> </tr> <tr> <td>1</td> <td>1</td> <td>1</td> <td>1</td> <td>1</td> <td>1</td> <td>1</td> <td>0</td> <td>Next station No. 254</td> </tr> <tr> <td>1</td> <td>1</td> <td>1</td> <td>1</td> <td>1</td> <td>1</td> <td>1</td> <td>1</td> <td>Setting inhibited (Note 2)</td> </tr> </tbody> </table>				Device (Note 1)								Selection contents	DI7	DI6	DI5	DI4	DI3	DI2	DI1	DI0	0	0	0	0	0	0	0	0	Next station No. 0	0	0	0	0	0	0	0	1	Next station No. 1	0	0	0	0	0	0	1	0	Next station No. 2	0	0	0	0	0	0	1	1	Next station No. 3	1	1	1	1	1	1	1	0	Next station No. 254	1	1	1	1	1	1	1	1	Setting inhibited (Note 2)	○
Device (Note 1)								Selection contents																																																																																								
DI7	DI6	DI5					DI4		DI3	DI2	DI1	DI0																																																																																				
0	0	0					0	0	0	0	0	Next station No. 0																																																																																				
0	0	0					0	0	0	0	1	Next station No. 1																																																																																				
0	0	0					0	0	0	1	0	Next station No. 2																																																																																				
0	0	0					0	0	0	1	1	Next station No. 3																																																																																				
.																																																																																							
.																																																																																								
1	1	1	1	1	1	1	0	Next station No. 254																																																																																								
1	1	1	1	1	1	1	1	Setting inhibited (Note 2)																																																																																								
Next station No. selection 3	DI2	CN1-10	○																																																																																													
Next station No. selection 4	DI3	CN1-35	○																																																																																													
Next station No. selection 5	DI4	/	△																																																																																													
Next station No. selection 6	DI5	/	△																																																																																													
Next station No. selection 7	DI6	/	△																																																																																													
Next station No. selection 8	DI7	/	△																																																																																													
			Note 1. 0: Off 1: On 2. [AL. 97.2 Next station position warning] will occur.																																																																																													
Second acceleration/deceleration selection	RT	/	Turning on ST1 with RT-off will select acceleration/deceleration time constants set with [Pr. PC01 Acceleration time constant 1] and [Pr. PC02 Deceleration time constant 1]. Turning on ST1 with RT-on will select acceleration/deceleration time constants set with [Pr. PC30 Acceleration time constant 2] and [Pr. PC31 Deceleration time constant 2]. RT will not be accepted during operation.	DI-1	/	/	△																																																																																									
			<table border="1"> <thead> <tr> <th>Device (Note)</th> <th colspan="2">Description</th> </tr> </thead> <tbody> <tr> <td>RT</td> <td>Acceleration time constant</td> <td>Deceleration time constant</td> </tr> <tr> <td>0</td> <td>[Pr. PC01]</td> <td>[Pr. PC02]</td> </tr> <tr> <td>1</td> <td>[Pr. PC30]</td> <td>[Pr. PC31]</td> </tr> </tbody> </table>	Device (Note)	Description		RT	Acceleration time constant	Deceleration time constant	0	[Pr. PC01]	[Pr. PC02]	1	[Pr. PC30]	[Pr. PC31]																																																																																	
Device (Note)	Description																																																																																															
RT	Acceleration time constant	Deceleration time constant																																																																																														
0	[Pr. PC01]	[Pr. PC02]																																																																																														
1	[Pr. PC30]	[Pr. PC31]																																																																																														
			Note. 0: Off 1: On																																																																																													
Second acceleration/deceleration gain selection	RTCDP	/	This has two functions of CDP (Gain switching) and RT (Second acceleration/deceleration selection). When RTCDP is off, the servo control gain set with [Pr. PB06], [Pr. PB08] to [Pr. PB10] will be selected. Turning on ST1 (Forward rotation start) will select acceleration/deceleration time constants set with [Pr. PC01 Acceleration time constant 1] and [Pr. PC02 Deceleration time constant 1]. When RTCDP is on, the servo control gain set with [Pr. PB29] to [Pr. PB32] will be selected. Turning on ST1 (Forward rotation start) will select acceleration/deceleration time constants set with [Pr. PC30 Acceleration time constant 2] and [Pr. PC31 Deceleration time constant 2].	DI-1	/	/	△																																																																																									

2. SIGNALS AND WIRING

Device	Symbol	Connector pin No.	Function and application	I/O division	Control mode																																																																																											
					CP/BCD	CL	PS																																																																																									
Digital override selection 1	OV0		<p>To enable the digital override function, set [Pr. PT38] to " __ 1 _". This signal is for multiplying a command speed by the digital override (multiplying factor). A command speed multiplied by the digital override value selected with this signal will be an actual servo motor speed. If the servo motor speed multiplied by the digital override value exceeds the servo motor maximum speed, the speed will be limited at the maximum speed.</p> <p>The following table shows an example of setting "50" to [Pr. PT42] and "5" to [Pr. PT43].</p> <table border="1"> <thead> <tr> <th colspan="4">Device (Note)</th> <th rowspan="2">Description</th> </tr> <tr> <th>OV3</th> <th>OV2</th> <th>OV1</th> <th>OV0</th> </tr> </thead> <tbody> <tr><td>0</td><td>0</td><td>0</td><td>0</td><td>100 [%] of command speed</td></tr> <tr><td>0</td><td>0</td><td>0</td><td>1</td><td>50 [%] of command speed</td></tr> <tr><td>0</td><td>0</td><td>1</td><td>0</td><td>55 [%] of command speed</td></tr> <tr><td>0</td><td>0</td><td>1</td><td>1</td><td>60 [%] of command speed</td></tr> <tr><td>0</td><td>1</td><td>0</td><td>0</td><td>65 [%] of command speed</td></tr> <tr><td>0</td><td>1</td><td>0</td><td>1</td><td>70 [%] of command speed</td></tr> <tr><td>0</td><td>1</td><td>1</td><td>0</td><td>75 [%] of command speed</td></tr> <tr><td>0</td><td>1</td><td>1</td><td>1</td><td>80 [%] of command speed</td></tr> <tr><td>1</td><td>0</td><td>0</td><td>0</td><td>85 [%] of command speed</td></tr> <tr><td>1</td><td>0</td><td>0</td><td>1</td><td>90 [%] of command speed</td></tr> <tr><td>1</td><td>0</td><td>1</td><td>0</td><td>95 [%] of command speed</td></tr> <tr><td>1</td><td>0</td><td>1</td><td>1</td><td>100 [%] of command speed</td></tr> <tr><td>1</td><td>1</td><td>0</td><td>0</td><td>105 [%] of command speed</td></tr> <tr><td>1</td><td>1</td><td>0</td><td>1</td><td>110 [%] of command speed</td></tr> <tr><td>1</td><td>1</td><td>1</td><td>0</td><td>115 [%] of command speed</td></tr> <tr><td>1</td><td>1</td><td>1</td><td>1</td><td>0 [%] of command speed</td></tr> </tbody> </table> <p>Note. 0: Off 1: On</p>	Device (Note)				Description	OV3	OV2	OV1	OV0	0	0	0	0	100 [%] of command speed	0	0	0	1	50 [%] of command speed	0	0	1	0	55 [%] of command speed	0	0	1	1	60 [%] of command speed	0	1	0	0	65 [%] of command speed	0	1	0	1	70 [%] of command speed	0	1	1	0	75 [%] of command speed	0	1	1	1	80 [%] of command speed	1	0	0	0	85 [%] of command speed	1	0	0	1	90 [%] of command speed	1	0	1	0	95 [%] of command speed	1	0	1	1	100 [%] of command speed	1	1	0	0	105 [%] of command speed	1	1	0	1	110 [%] of command speed	1	1	1	0	115 [%] of command speed	1	1	1	1	0 [%] of command speed	DI-1			△
Device (Note)				Description																																																																																												
OV3	OV2				OV1	OV0																																																																																										
0	0			0	0	100 [%] of command speed																																																																																										
0	0	0	1	50 [%] of command speed																																																																																												
0	0	1	0	55 [%] of command speed																																																																																												
0	0	1	1	60 [%] of command speed																																																																																												
0	1	0	0	65 [%] of command speed																																																																																												
0	1	0	1	70 [%] of command speed																																																																																												
0	1	1	0	75 [%] of command speed																																																																																												
0	1	1	1	80 [%] of command speed																																																																																												
1	0	0	0	85 [%] of command speed																																																																																												
1	0	0	1	90 [%] of command speed																																																																																												
1	0	1	0	95 [%] of command speed																																																																																												
1	0	1	1	100 [%] of command speed																																																																																												
1	1	0	0	105 [%] of command speed																																																																																												
1	1	0	1	110 [%] of command speed																																																																																												
1	1	1	0	115 [%] of command speed																																																																																												
1	1	1	1	0 [%] of command speed																																																																																												
Digital override selection 2	OV1						△																																																																																									
Digital override selection 3	OV2						△																																																																																									
Digital override selection 4	OV3						△																																																																																									
Mark detection	MSD		The current position latch function by sensor input can be used. For the current position latch function, refer to section 12.2.1. For the current position latch function, refer to section 12.2.2.	DI-1	△	△																																																																																										

2. SIGNALS AND WIRING

Device	Symbol	Connector pin No.	Function and application	I/O division	Control mode																																																																				
					CP/BCD	CL	CL																																																																		
Proportion control	PC		Turn PC on to switch the speed amplifier from the proportional integral type to the proportional type. If the servo motor at a stop is rotated even one pulse due to any external factor, it generates torque to compensate for a position shift. When the servo motor shaft is to be locked mechanically after positioning completion (stop), switching on the PC (Proportion control) upon positioning completion will suppress the unnecessary torque generated to compensate for a position shift. When the shaft is to be locked for a long time, switch on the PC (Proportion control) and TL (External torque limit selection) at the same time to make the torque less than the rated by TLA (Analog torque limit).	DI-1	△	△	△																																																																		
Clear	CR		Turn CR on to clear the position control counter droop pulse on its leading edge. The pulse width should be 10 ms or longer. The delay amount set in [Pr. PB03 Position command acceleration/deceleration time constant] is also cleared. When "___1" is set to [Pr. PD32], the pulses are always cleared while CR is on.	DI-1	△	△	△																																																																		
Gain switching	CDP		Turn on CDP to use the values of [Pr. PB29] to [Pr. PB36] and [Pr. PB56] to [Pr. PB60] as the load to motor inertia ratio and gain values.	DI-1	△	△	△																																																																		
Fully closed loop selection	CLD		Not used with the positioning mode.	DI-1																																																																					
Motor-side/load-side deviation counter clear	MECR		Turn on MECR to clear the motor-side/load-side position deviation counter to zero. <ul style="list-style-type: none"> It operates during the fully closed loop control. It does not affect the position control droop pulses. Turning on this device during the semi closed loop control does not affect the operation. Turning on this device while the fully closed loop control error detection function is disabled in [Pr. PE03] does not affect the operation. This device is not available with MR-J4-03A6-RJ servo amplifiers.	DI-1	△	△																																																																			
Cam control command	CAMC		When using CAMC, set [Pr. PT35] to "_ 1 _" to enable it. Turning CAMC on switches the control from the normal positioning control to the cam control.	DI-1	△	△																																																																			
Cam position compensation request	CPCD		Turning CPCD on compensates the cam axis one cycle current value to be in the position set in [Cam control data No. 60 - Cam position compensation target position].	DI-1	△	△																																																																			
Clutch command	CLTC		This is used to turning on/off the main shaft clutch command. This is used when [Cam control data No. 36 - Main shaft clutch control setting] is set to "___ 1".	DI-1	△	△																																																																			
Cam No. selection 0	CI0		Select cam No. This is enabled when [Cam control data No. 49 - Cam No.] is set to "0". Set the cam control data on the cam setting window of MR Configurator2.	DI-1	△	△																																																																			
Cam No. selection 1	CI1		<table border="1"> <thead> <tr> <th colspan="4">Device (Note 1)</th> <th rowspan="2">Selection contents</th> </tr> <tr> <th>CI3</th> <th>CI2</th> <th>CI1</th> <th>CI0</th> </tr> </thead> <tbody> <tr> <td>0</td> <td>0</td> <td>0</td> <td>0</td> <td>Linear cam</td> </tr> <tr> <td>0</td> <td>0</td> <td>0</td> <td>1</td> <td>Cam No. 1</td> </tr> <tr> <td>0</td> <td>0</td> <td>1</td> <td>0</td> <td>Cam No. 2</td> </tr> <tr> <td>0</td> <td>0</td> <td>1</td> <td>1</td> <td>Cam No. 3</td> </tr> <tr> <td>.</td> <td>.</td> <td>.</td> <td>.</td> <td>.</td> </tr> <tr> <td>.</td> <td>.</td> <td>.</td> <td>.</td> <td>.</td> </tr> <tr> <td>.</td> <td>.</td> <td>.</td> <td>.</td> <td>.</td> </tr> <tr> <td>1</td> <td>0</td> <td>0</td> <td>0</td> <td>Cam No. 8</td> </tr> <tr> <td>1</td> <td>0</td> <td>0</td> <td>1</td> <td rowspan="3">Setting inhibited (Note 2)</td> </tr> <tr> <td>.</td> <td>.</td> <td>.</td> <td>.</td> </tr> <tr> <td>.</td> <td>.</td> <td>.</td> <td>.</td> </tr> <tr> <td>1</td> <td>1</td> <td>1</td> <td>1</td> <td></td> </tr> </tbody> </table>	Device (Note 1)				Selection contents	CI3	CI2	CI1	CI0	0	0	0	0	Linear cam	0	0	0	1	Cam No. 1	0	0	1	0	Cam No. 2	0	0	1	1	Cam No. 3	1	0	0	0	Cam No. 8	1	0	0	1	Setting inhibited (Note 2)	1	1	1	1		△	△	
Device (Note 1)				Selection contents																																																																					
CI3	CI2	CI1			CI0																																																																				
0	0	0		0	Linear cam																																																																				
0	0	0		1	Cam No. 1																																																																				
0	0	1		0	Cam No. 2																																																																				
0	0	1		1	Cam No. 3																																																																				
.																																																																					
.																																																																					
.																																																																					
1	0	0	0	Cam No. 8																																																																					
1	0	0	1	Setting inhibited (Note 2)																																																																					
.	.	.	.																																																																						
.	.	.	.																																																																						
1	1	1	1																																																																						
Cam No. selection 2	CI2			△	△																																																																				
Cam No. selection 3	CI3			△	△																																																																				

Note 1. 0: Off
1: On

2. [AL. F6.5 Cam No. external error] occurs.

2. SIGNALS AND WIRING

(b) Output device

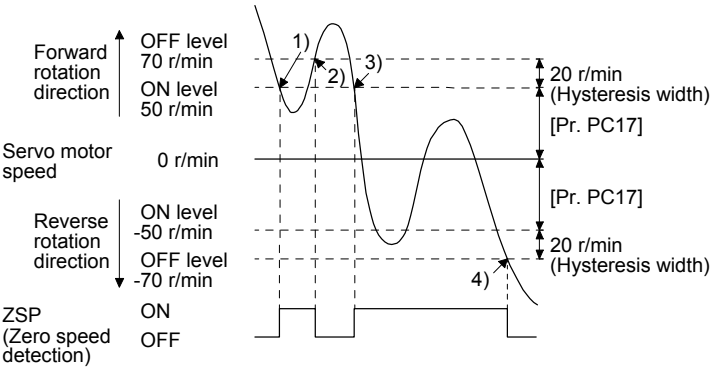
Device	Symbol	Connector pin No.	Function and application	I/O division	Control mode		
					CP/BCD	LC	SL
Malfunction	ALM	CN1-48	When an alarm occurs, ALM will turn off. When an alarm does not occur, ALM will turn on after 4 s to 5 s after power-on. When [Pr. PD34] is "_ _ 1 _", an alarming or warning will turn off ALM.	DO-1	○	○	○
Malfunction/Warning	ALM WNG		When an alarm occurs, ALMWNG will turn off. When a warning (except [AL. 9F Battery warning]) occurs on and off will be repeated every 1 s. When an alarm/warning is not occurring, turning on the power will turn on ALMWNG after 4 s to 5 s.	DO-1	△	△	△
Warning	WNG		When warning has occurred, WNG turns on. When a warning is not occurring, turning on the power will turn off WNG after 4 s to 5 s.	DO-1	△	△	△
Battery warning	BWNG		BWNG turns on when [AL. 92 Battery cable disconnection warning] or [AL. 9F Battery warning] has occurred. When the battery warning is not occurring, turning on the power will turn off BWNG after 4 s to 5 s.	DO-1	△	△	△
AL9F warning	BW9F		When [AL. 9F Battery warning] occurs, BW9F will turn on.	DO-1	△	△	△
Dynamic brake interlock	DB		When using the signal, enable it by setting [Pr. PD23] to [Pr. PD26], [Pr. PD28], and [Pr. PD47]. DB turns off when the dynamic brake needs to operate. When using an external dynamic brake with the servo amplifier of 11 kW or more, this device is required. (Refer to "MR-J4-_A_(-RJ) Servo Amplifier Instruction Manual" section 11.17.) For the servo amplifier of 7 kW or less, it is not necessary to use this device.	DO-1	△	△	△
Ready	RD	CN1-49	Enabling servo-on to make the servo amplifier ready to operate will turn on RD.	DO-1	○	○	○
In-position	INP	CN1-24	When the number of droop pulses is in the preset in-position range, INP will turn on. The in-position range can be changed using [Pr. PA10]. When the in-position range is increased, INP may be on during low-speed rotation. INP turns on when servo-on turns on.	DO-1	○	○	○
Limiting torque	TLC	CN1-25	TLC turns on when a generated torque reaches a value set with any of [Pr. PA11 Forward torque limit], [Pr. PA12 Reverse torque limit], or TLA (Analog torque limit).	DO-1	○	○	○
Zero speed detection	ZSP	CN1-23	ZSP turns on when the servo motor speed is zero speed (50 r/min) or less. Zero speed can be changed with [Pr. PC17].  <p>Forward rotation direction: OFF level 70 r/min, ON level 50 r/min</p> <p>Servo motor speed: 0 r/min</p> <p>Reverse rotation direction: ON level -50 r/min, OFF level -70 r/min</p> <p>ZSP (Zero speed detection): ON, OFF</p> <p>20 r/min (Hysteresis width) [Pr. PC17]</p> <p>[Pr. PC17]</p> <p>20 r/min (Hysteresis width)</p> <p>ZSP will turn on when the servo motor is decelerated to 50 r/min (at 1)), and will turn off when the servo motor is accelerated to 70 r/min again (at 2)). ZSP will turn on when the servo motor is decelerated again to 50 r/min (at 3)), and will turn off when the servo motor speed has reached -70 r/min (at 4)). The range from the point when the servo motor speed has reached on level, and ZSP turns on, to the point when it is accelerated again and has reached off level is called hysteresis width. Hysteresis width is 20 r/min for this servo amplifier.</p>	DO-1	○	○	○

2. SIGNALS AND WIRING

Device	Symbol	Connector pin No.	Function and application	I/O division	Control mode		
					CP/BCD	CU	CS
Electromagnetic brake interlock	MBR		When using the device, set operation delay time of the electromagnetic brake in [Pr. PC16]. When a servo-off status or alarm occurs, MBR will turn off.	DO-1	△	△	△
Speed command reached	SA		When a command speed is within a target speed at servo-on status, SA will be on. When the command speed is 0 r/min (mm/s), this will be continuously on. When the command speed is in acceleration/deceleration or at servo-off status, SA will be off.	DO-1	△	△	
Home position return completion	ZP		When a home position return completes normally, ZP (Home position return completion) will be on. This will be off with the following conditions in the incremental system. 1) SON (Servo-on) is off. 2) EM2 (Forced stop 2) is off. 3) RES (Reset) is on. 4) At alarm occurrence 5) LSP (Forward rotation stroke end) or LSN (Reverse rotation stroke end) is off. 6) Home position return is not being executed. 7) Software limit is being detected. 8) Home position return is in progress. If once home position return is completed in the absolute position detection system, ZP (Home position return completion) will be the same output status as RD (Ready). However, it will be off with the above 1) to 8) and the following 9) to 14). 9) The home position return is not performed after [AL. 25 Absolute position erased] or [AL. E3 Absolute position counter warning] occurred. 10) The home position return is not performed after the electronic gear ([Pr. PA06] and [Pr. PA07]) was changed. 11) The home position return is not performed after the setting of [Pr. PA03 Absolute position detection system selection] was changed from "Disabled" to "Enabled". 12) [Pr. PA14 Rotation direction selection/travel direction selection] was changed. 13) [Pr. PA01 Operation mode] was changed. 14) [Pr. PT08 Home position return position data] or [Pr. PT28 Number of stations per rotation] was changed.	DO-1	△	△	△
Rough match	CPO		When a command remaining distance is lower than the rough match output range set with [Pr. PT12], CPO will be on. This is not outputted during base circuit shut-off. CPO turns on with servo-on.	DO-1	△	△	△
Position range output	POT		When an actual current position is within the range set with [Pr. PT21] and [Pr. PT22], POT will be on. This will be off when a home position return does not complete or base circuit shut-off is in progress.	DO-1	△	△	
Temporary stop	PUS		When a deceleration begins for a stop, PUS will be on by TSTP (Temporary stop/restart). When you enable TSTP (Temporary stop/restart) again and start operation, PUS will be off.	DO-1	△	△	
Travel completion	MEND		When the droop pulses are within the in-position output range set with [Pr. PA10] and the command remaining distance is "0", MEND will be on. MEND turns on with servo-on. MEND is off at servo-off status. However, MEND will not be off in the indexer method.	DO-1	△	△	△
Position end	PED		When the droop pulses are within the position end output range set with [Pr. PA10] and the command remaining distance is "0", PED will be on. When MEND (Travel completion) is on and ZP (Home position return completion) is on, PED (Position end) will be on. When ZP (Home position return completion) is on with servo-on status, PED will be on. PED is off at servo-off status.	DO-1	△	△	
SYNC synchronous output	SOUT		When the status is waiting for input of the program SYNC (1 to 3), SOUT will be on. When PI1 (Program input 1) to PI3 (Program input 3) turn on, SOUT will be off.	DO-1		△	

2. SIGNALS AND WIRING

Device	Symbol	Connector pin No.	Function and application	I/O division	Control mode																																																																																																													
					CP/BCD	CU	CS																																																																																																											
Program output 1	OUT1		OUT1 will turn on with the OUTON (1) command during programming. The OUTOF (1) command will turn off OUT1. You can also set time to off with [Pr. PT23].	DO-1		Δ																																																																																																												
Program output 2	OUT2		OUT2 will turn on with the OUTON (2) command during programming. The OUTOF (2) command will turn off OUT2. You can also set time to off with [Pr. PT24].	DO-1		Δ																																																																																																												
Program output 3	OUT3		OUT3 will turn on with the OUTON (3) command during programming. The OUTOF (3) command will turn off OUT3. You can also set time to off with [Pr. PT25].	DO-1		Δ																																																																																																												
Point table No. output 1	PT0		The signals output point table Nos. in 8 bit code simultaneously with MEND (Travel completion) on.	DO-1	Δ																																																																																																													
Point table No. output 2	PT1		<table border="1"> <thead> <tr> <th colspan="8">Device (Note 1, 2)</th> <th rowspan="2">Description</th> </tr> <tr> <th>PT7</th> <th>PT6</th> <th>PT5</th> <th>PT4</th> <th>PT3</th> <th>PT2</th> <th>PT1</th> <th>PT0</th> </tr> </thead> <tbody> <tr> <td>0</td> <td>0</td> <td>0</td> <td>0</td> <td>0</td> <td>0</td> <td>0</td> <td>1</td> <td>Point table No. 1</td> </tr> <tr> <td>0</td> <td>0</td> <td>0</td> <td>0</td> <td>0</td> <td>0</td> <td>1</td> <td>0</td> <td>Point table No. 2</td> </tr> <tr> <td>0</td> <td>0</td> <td>0</td> <td>0</td> <td>0</td> <td>0</td> <td>1</td> <td>1</td> <td>Point table No. 3</td> </tr> <tr> <td>.</td> <td>.</td> <td>.</td> <td>.</td> <td>.</td> <td>.</td> <td>.</td> <td>.</td> <td>.</td> </tr> <tr> <td>.</td> <td>.</td> <td>.</td> <td>.</td> <td>.</td> <td>.</td> <td>.</td> <td>.</td> <td>.</td> </tr> <tr> <td>.</td> <td>.</td> <td>.</td> <td>.</td> <td>.</td> <td>.</td> <td>.</td> <td>.</td> <td>.</td> </tr> <tr> <td>1</td> <td>1</td> <td>1</td> <td>1</td> <td>1</td> <td>1</td> <td>1</td> <td>0</td> <td>Point table No. 254</td> </tr> <tr> <td>1</td> <td>1</td> <td>1</td> <td>1</td> <td>1</td> <td>1</td> <td>1</td> <td>1</td> <td>Point table No. 255</td> </tr> </tbody> </table> <p>Note 1. 0: Off 1: On</p> <p>2. For MR-J4-03A6-RJ servo amplifiers, up to six points of DO are available; therefore, PT0 to PT7 cannot be outputted simultaneously.</p>	Device (Note 1, 2)								Description	PT7	PT6	PT5	PT4	PT3	PT2	PT1	PT0	0	0	0	0	0	0	0	1	Point table No. 1	0	0	0	0	0	0	1	0	Point table No. 2	0	0	0	0	0	0	1	1	Point table No. 3	1	1	1	1	1	1	1	0	Point table No. 254	1	1	1	1	1	1	1	1	Point table No. 255	DO-1	Δ																				
Device (Note 1, 2)								Description																																																																																																										
PT7	PT6	PT5		PT4	PT3	PT2	PT1		PT0																																																																																																									
0	0	0		0	0	0	0	1	Point table No. 1																																																																																																									
0	0	0		0	0	0	1	0	Point table No. 2																																																																																																									
0	0	0		0	0	0	1	1	Point table No. 3																																																																																																									
.																																																																																																									
.																																																																																																									
.																																																																																																									
1	1	1	1	1	1	1	0	Point table No. 254																																																																																																										
1	1	1	1	1	1	1	1	Point table No. 255																																																																																																										
Point table No. output 3	PT2			DO-1	Δ																																																																																																													
Point table No. output 4	PT3			DO-1	Δ																																																																																																													
Point table No. output 5	PT4			DO-1	Δ																																																																																																													
Point table No. output 6	PT5			DO-1	Δ																																																																																																													
Point table No. output 7	PT6			DO-1	Δ																																																																																																													
Point table No. output 8	PT7			DO-1	Δ																																																																																																													
Station output 1	PS0		The signals output station Nos. simultaneously with MEND on while an alarm is not occurring.	DO-1			Δ																																																																																																											
Station output 2	PS1		<table border="1"> <thead> <tr> <th colspan="8">Device (Note 1, 2)</th> <th rowspan="2">Description</th> </tr> <tr> <th>PS7</th> <th>PS6</th> <th>PS5</th> <th>PS4</th> <th>PS3</th> <th>PS2</th> <th>PS1</th> <th>PS0</th> </tr> </thead> <tbody> <tr> <td>0</td> <td>0</td> <td>0</td> <td>0</td> <td>0</td> <td>0</td> <td>0</td> <td>0</td> <td>In-position out of range</td> </tr> <tr> <td>1</td> <td>1</td> <td>1</td> <td>1</td> <td>1</td> <td>1</td> <td>1</td> <td>1</td> <td>Next station No. 0</td> </tr> <tr> <td>1</td> <td>1</td> <td>1</td> <td>1</td> <td>1</td> <td>1</td> <td>1</td> <td>0</td> <td>Next station No. 1</td> </tr> <tr> <td>1</td> <td>1</td> <td>1</td> <td>1</td> <td>1</td> <td>1</td> <td>0</td> <td>1</td> <td>Next station No. 2</td> </tr> <tr> <td>1</td> <td>1</td> <td>1</td> <td>1</td> <td>1</td> <td>1</td> <td>0</td> <td>0</td> <td>Next station No. 3</td> </tr> <tr> <td>.</td> <td>.</td> <td>.</td> <td>.</td> <td>.</td> <td>.</td> <td>.</td> <td>.</td> <td>.</td> </tr> <tr> <td>.</td> <td>.</td> <td>.</td> <td>.</td> <td>.</td> <td>.</td> <td>.</td> <td>.</td> <td>.</td> </tr> <tr> <td>.</td> <td>.</td> <td>.</td> <td>.</td> <td>.</td> <td>.</td> <td>.</td> <td>.</td> <td>.</td> </tr> <tr> <td>0</td> <td>0</td> <td>0</td> <td>0</td> <td>0</td> <td>0</td> <td>1</td> <td>0</td> <td>Next station No. 253</td> </tr> <tr> <td>0</td> <td>0</td> <td>0</td> <td>0</td> <td>0</td> <td>0</td> <td>0</td> <td>1</td> <td>Next station No. 254</td> </tr> </tbody> </table> <p>Note 1. 0: Off 1: On</p> <p>2. For MR-J4-03A6-RJ servo amplifiers, up to six points of DO are available; therefore, PS0 to PS7 cannot be outputted simultaneously.</p>	Device (Note 1, 2)								Description	PS7	PS6	PS5	PS4	PS3	PS2	PS1	PS0	0	0	0	0	0	0	0	0	In-position out of range	1	1	1	1	1	1	1	1	Next station No. 0	1	1	1	1	1	1	1	0	Next station No. 1	1	1	1	1	1	1	0	1	Next station No. 2	1	1	1	1	1	1	0	0	Next station No. 3	0	0	0	0	0	0	1	0	Next station No. 253	0	0	0	0	0	0	0	1	Next station No. 254	DO-1			Δ
Device (Note 1, 2)								Description																																																																																																										
PS7	PS6	PS5		PS4	PS3	PS2	PS1		PS0																																																																																																									
0	0	0		0	0	0	0	0	In-position out of range																																																																																																									
1	1	1		1	1	1	1	1	Next station No. 0																																																																																																									
1	1	1		1	1	1	1	0	Next station No. 1																																																																																																									
1	1	1		1	1	1	0	1	Next station No. 2																																																																																																									
1	1	1		1	1	1	0	0	Next station No. 3																																																																																																									
.																																																																																																									
.																																																																																																										
.																																																																																																										
0	0	0	0	0	0	1	0	Next station No. 253																																																																																																										
0	0	0	0	0	0	0	1	Next station No. 254																																																																																																										
Station output 3	PS2			DO-1			Δ																																																																																																											
Station output 4	PS3			DO-1			Δ																																																																																																											
Station output 5	PS4			DO-1			Δ																																																																																																											
Station output 6	PS5			DO-1			Δ																																																																																																											
Station output 7	PS6			DO-1			Δ																																																																																																											
Station output 8	PS7			DO-1			Δ																																																																																																											

2. SIGNALS AND WIRING

Device	Symbol	Connector pin No.	Function and application	I/O division	Control mode																																																													
					CP/BCD	CL	PS																																																											
M code 1 (bit 0)	MCD00		<p>This device can be used in the point table method.</p> <p>These signals can be checked with output devices of the communication function. (Refer to section 10.2 (1).)</p> <p>To use these signals, set " __ 1 _ " in [Pr. Po12].</p> <p>The signals output M code simultaneously with CPO (Rough match) on. Set M code with point tables.</p> <p>The code represents one digit of decimal using four digits of binary. The following shows correspondence of each digit and device.</p> <div style="text-align: center;"> </div> <table border="1" style="margin: 10px auto;"> <thead> <tr> <th>M code</th> <th colspan="4">Device (Note)</th> </tr> <tr> <th>First/second digit</th> <th>MCD03/ MCD13</th> <th>MCD02/ MCD12</th> <th>MCD01/ MCD11</th> <th>MCD00/ MCD10</th> </tr> </thead> <tbody> <tr><td>0</td><td>0</td><td>0</td><td>0</td><td>0</td></tr> <tr><td>1</td><td>0</td><td>0</td><td>0</td><td>1</td></tr> <tr><td>2</td><td>0</td><td>0</td><td>1</td><td>0</td></tr> <tr><td>3</td><td>0</td><td>0</td><td>1</td><td>1</td></tr> <tr><td>4</td><td>0</td><td>1</td><td>0</td><td>0</td></tr> <tr><td>5</td><td>0</td><td>1</td><td>0</td><td>1</td></tr> <tr><td>6</td><td>0</td><td>1</td><td>1</td><td>0</td></tr> <tr><td>7</td><td>0</td><td>1</td><td>1</td><td>1</td></tr> <tr><td>8</td><td>1</td><td>0</td><td>0</td><td>0</td></tr> <tr><td>9</td><td>1</td><td>0</td><td>0</td><td>1</td></tr> </tbody> </table> <p>Note. 0: Off 1: On</p> <p>MCD00 to MCD03 and MCD10 to MCD13 will turn off with the following status.</p> <ul style="list-style-type: none"> ▪ Power on ▪ Servo-off ▪ Manual operation mode ▪ At alarm occurrence 	M code	Device (Note)				First/second digit	MCD03/ MCD13	MCD02/ MCD12	MCD01/ MCD11	MCD00/ MCD10	0	0	0	0	0	1	0	0	0	1	2	0	0	1	0	3	0	0	1	1	4	0	1	0	0	5	0	1	0	1	6	0	1	1	0	7	0	1	1	1	8	1	0	0	0	9	1	0	0	1	DO-1		
M code	Device (Note)																																																																	
First/second digit	MCD03/ MCD13	MCD02/ MCD12		MCD01/ MCD11	MCD00/ MCD10																																																													
0	0	0		0	0																																																													
1	0	0		0	1																																																													
2	0	0		1	0																																																													
3	0	0		1	1																																																													
4	0	1		0	0																																																													
5	0	1	0	1																																																														
6	0	1	1	0																																																														
7	0	1	1	1																																																														
8	1	0	0	0																																																														
9	1	0	0	1																																																														
M code 2 (bit 1)	MCD01		DO-1																																																															
M code 3 (bit 2)	MCD02		DO-1																																																															
M code 4 (bit 3)	MCD03		DO-1																																																															
M code 5 (bit 4)	MCD10		DO-1																																																															
M code 6 (bit 5)	MCD11		DO-1																																																															
M code 7 (bit 6)	MCD12		DO-1																																																															
M code 8 (bit 7)	MCD13		DO-1																																																															

2. SIGNALS AND WIRING

Device	Symbol	Connector pin No.	Function and application	I/O division	Control mode		
					CP/BCD	CL	PS
Mark detection rising latch completed	MSDH		Turning on MSD (Mark detection) will turn on MSDH.	DO-1	△	△	
Mark detection falling latch completed	MSDL		After MSD (Mark detection) is turned on, turning off MSD will turn on MSDL.	DO-1	△	△	
Alarm code	ACD0	(CN1-24)	To use these signals, set " _ _ _ 1" in [Pr. PD34]. This signal is outputted when an alarm occurs. When an alarm is not occurring, respective ordinary signals are outputted. For details of the alarm codes, refer to chapter 8. When [Pr. PD34] is set to " _ _ _ 1", setting the following will trigger [AL. 37 Parameter error]. • " _ _ _ 1" is set in [Pr. PA03] and the absolute position detection system by DIO is selected. • MBR, DB, or ALM is assigned to the CN1-22 pin, CN1-23 pin, or CN1-24 pin.	DO-1	△	△	△
	ACD1	(CN1-23)					
	ACD2	(CN1-22)					
Variable gain selection	CDPS		CDPS turns on during gain switching.	DO-1	△	△	△
Absolute position undetermined	ABSV		ABSV turns on when the absolute position is undetermined.	DO-1	△	△	△
During tough drive	MTTR		When a tough drive is "Enabled" in [Pr. PA20], activating the instantaneous power failure tough drive will turn on MTTR. This device is not available with MR-J4-03A6-RJ servo amplifiers.	DO-1	△	△	△
During fully closed loop control	CLDS		CLDS turns on during fully closed loop control. This device is not available with MR-J4-03A6-RJ servo amplifiers.	DO-1	△	△	
Under cam control	CAMS		It turns on when the control switches to the cam control. It turns off when the control switches to the normal positioning control.	DO-1	△	△	
Cam position compensation execution completed	CPCC		It turns on when the cam compensation execution is enabled. It turns on when the position compensation is not being executed during the cam control.	DO-1	△	△	
Clutch on/off status	CLTS		It turns on with clutch-on. It is always off when [Cam control data No. 36 - Main shaft clutch control setting] is set to " _ _ _ 0".	DO-1	△	△	
Clutch smoothing status	CLTSM		It outputs clutch smoothing status. The output depends on the setting in [Cam control data No. 42 - Main shaft clutch smoothing system] as follows: 0: Direct Always off 1: Time constant method (index) Always on in clutch-on status It turns off when the clutch is off and the smoothing is complete.	DO-1	△	△	

(2) Input signal

Device	Symbol	Connector pin No.	Function and application	I/O division	Control mode		
					CP/BCD	CL	PS
Manual pulse generator	PP	(CN1-10)	Connect the manual pulse generator (MR-HDP01). When using the signal, enable PP and NP with [Pr. PD44] and [Pr. PD46].	DI-2	△	△	
	NP	(CN1-35)					

2. SIGNALS AND WIRING

Device	Symbol	Connector pin No.	Function and application	I/O division	Control mode		
					CP/BCD	CL	PS
Analog torque limit	TLA	CN1-27	<p>When using the signal, enable TL (External torque limit selection) with [Pr. PD04], [Pr. PD06], [Pr. PD08], [Pr. PD10], [Pr. PD12], [Pr. PD14], [Pr. PD18], [Pr. PD20], [Pr. PD22], [Pr. PD44], and [Pr. PD46].</p> <p>When TLA is enabled, torque is limited in the full servo motor output torque range. Apply 0 V to +10 V DC between TLA and LG. Connect the positive terminal of the power supply to TLA. The maximum torque is generated at +10 V. (Refer to section 3.6.1 (5) of "MR-J4-_A_(-RJ) Servo Amplifier Instruction Manual".)</p> <p>If a value equal to or larger than the maximum torque is inputted to TLA, the value is clamped at the maximum torque.</p> <p>Resolution: 10 bits</p>	Analog input	△	△	△
Analog override	VC	CN1-2	<p>The signal controls the servo motor setting speed by applying -10 V to +10 V to between VC and LG. The percentage will be 0% with -10 V, 100% with 0 V, and 200% with +10 V to the setting speed of the servo motor.</p> <p>Resolution: 14 bits or equivalent</p> <p>For MR-J4-_A_-RJ 100 W or more servo amplifiers, setting [Pr. PC60] to "_ _ 1 _" increases the analog input resolution to 16 bits. This function is available with servo amplifiers manufactured in November 2014 or later.</p>	Analog input	○	○	

(3) Output signal

(a) MR-J4-_A_-RJ 100 W or more

Device	Symbol	Connector pin No.	Function and application	I/O division	Control mode		
					CP/BCD	CL	PS
Encoder A-phase pulse (differential line driver)	LA LAR	CN1-4 CN1-5	<p>These devices output pulses of encoder output pulse set in [Pr. PA15] in the differential line driver type.</p> <p>In CCW rotation of the servo motor, the encoder B-phase pulse lags the encoder A-phase pulse by a phase angle of $\pi/2$.</p>	DO-2	○	○	○
Encoder B-phase pulse (differential line driver)	LB LBR	CN1-6 CN1-7	The relation between rotation direction and phase difference of the A-phase and B-phase pulses can be changed with [Pr. PC19].				
Encoder Z-phase pulse (differential line driver)	LZ LZR	CN1-8 CN1-9	<p>The encoder zero-point signal is outputted in the differential line driver type. One pulse is outputted per servo motor revolution. This turns on when the zero-point position is reached. (negative logic)</p> <p>The minimum pulse width is about 400 μs. For home position return using this pulse, set the creep speed to 100 r/min or less.</p>	DO-2	○	○	○
Encoder Z-phase pulse (open-collector)	OP	CN1-33	The encoder zero-point signal is outputted in the open-collector type.	DO-2	○	○	○
Analog monitor 1	MO1	CN6-3	<p>This is used to output the data set in [Pr. PC14] to between MO1 and LG in terms of voltage.</p> <p>Output voltage: ± 10 V</p> <p>Resolution: 10 bits or equivalent</p>	Analog output	○	○	○
Analog monitor 2	MO2	CN6-2	<p>This signal outputs the data set in [Pr. PC15] to between MO2 and LG in terms of voltage.</p> <p>Output voltage: ± 10 V</p> <p>Resolution: 10 bits or equivalent</p>	Analog output	○	○	○

2. SIGNALS AND WIRING

(b) MR-J4-03A6-RJ

Device	Symbol	Connector pin No.	Function and application	I/O division	Control mode		
					CP	CL	CS
Encoder A-phase pulse (differential line driver)	LA LAR	CN1-4 CN1-5	These devices output pulses of encoder output pulse set in [Pr. PA15] in the differential line driver type. In CCW rotation of the servo motor, the encoder B-phase pulse lags the encoder A-phase pulse by a phase angle of $\pi/2$.	DO-2	○	○	○
Encoder B-phase pulse (differential line driver)	LB LBR	CN1-6 CN1-7	The relation between rotation direction and phase difference of the A-phase and B-phase pulses can be changed with [Pr. PC19].				
Encoder Z-phase pulse (differential line driver)	LZ LZR	CN1-8 CN1-9	The encoder zero-point signal is outputted in the differential line driver type. One pulse is outputted per servo motor revolution. This turns on when the zero-point position is reached. (negative logic) The minimum pulse width is about 400 μ s. For home position return using this pulse, set the creep speed to 100 r/min or less.	DO-2	○	○	○
Encoder Z-phase pulse (open-collector)	OP	CN1-33	The encoder zero-point signal is outputted in the open-collector type.	DO-2	○	○	○
Analog monitor 1	MO1	CN1-26	This is used to output the data set in [Pr. PC14] to between MO1 and LG in terms of voltage. Output voltage: 5 V \pm 4 V Resolution: 10 bits or equivalent	Analog output	○	○	○
Analog monitor 2	MO2	CN1-29	This signal outputs the data set in [Pr. PC15] to between MO2 and LG in terms of voltage. Output voltage: 5 V \pm 4 V Resolution: 10 bits or equivalent	Analog output	○	○	○

(4) Communication

(a) MR-J4-_A_-RJ 100 W or more

Device	Symbol	Connector pin No.	Function and application	I/O division	Control mode		
					CP/BCD	CL	CS
RS-422/RS-485 I/F	SDP SDN RDP RDN	CN3-5 CN3-4 CN3-3 CN3-6	These are terminals for RS-422/RS-485 communication.		○	○	○

(b) MR-J4-03A6-RJ

Device	Symbol	Connector pin No.	Function and application	I/O division	Control mode		
					CP	CL	CS
RS-422 I/F	SDP SDN RDP RDN TRE	CN1-13 CN1-14 CN1-39 CN1-40 CN1-31	These are terminals for RS-422 communication.		○	○	○

2. SIGNALS AND WIRING

2.4 Analog override

POINT
<ul style="list-style-type: none"> ● The override function has two types. One is analog override by using analog voltage input and another is digital override by using parameter settings. <ul style="list-style-type: none"> ▪ Target method of analog override: Point table method/Program method ▪ Target method of digital override: Indexer method ● OVR (Analog override selection) is for the analog override. The digital override does not depend on OVR (Analog override selection). ● Refer to [Pr. PT38], [Pr. PT42], and [Pr. PT43] for the digital override. ● When using the analog override in the point table method or program method, enable OVR (Analog override selection). ● The following shows functions whether usable or not with the analog override. <ol style="list-style-type: none"> (1) Analog override usable <ul style="list-style-type: none"> ▪ Automatic operation mode (point table method/program method) ▪ JOG operation in the manual operation mode ▪ Automatic positioning to home position function in the point table method (2) Analog override unusable <ul style="list-style-type: none"> ▪ Manual pulse generator operation in the manual operation mode ▪ Home position return mode ▪ Test operation mode using MR Configurator2 (positioning operation/JOG operation)

You can change the servo motor speed by using VC (Analog override). The following table shows signals and parameters related to the analog override.

Item	Name	Remark
Analog input signal	VC (Analog override)	
Contact input signal	OVR (Analog override selection)	Turning on OVR will enable VC (Analog override) setting value.
Parameter	[Pr. PC37 Analog override offset]	-9999 to 9999 [mV]

(1) VC (Analog override)

You can continuously set changed values from outside by applying voltage (-10 V to +10 V) to VC (Analog override). The following shows percentage of the actual speed to input voltage and set speed.

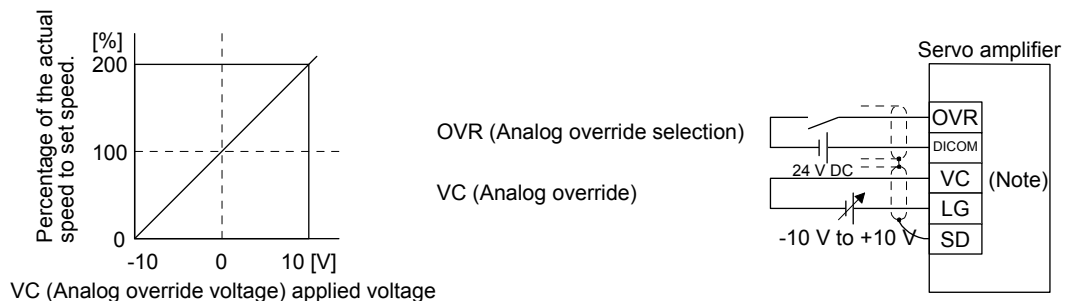

Note. This diagram shows sink input interface.

2. SIGNALS AND WIRING

- (2) OVR (Analog override selection)
 Select enabled/disabled of VC (Analog override).

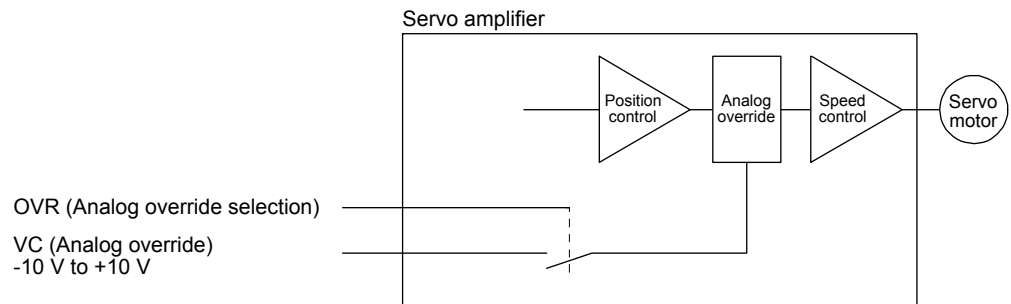

Select a changed value using OVR (Analog override selection).

(Note) External input signal	Speed change value
0	No change
1	Setting of VC (Analog override) is enabled.

Note. 0: Off
 1: On

- (3) Analog override offset ([Pr. PC37])
 You can set an offset voltage to the input voltage of VC (Analog override) with [Pr. PC37]. The setting value is from -9999 to +9999 [mV].

2. SIGNALS AND WIRING

2.5 Internal connection diagram

POINT
<ul style="list-style-type: none">● For details of interface and source I/O interface, refer to section 3.9 of "MR-J4-_A_(-RJ) Servo Amplifier Instruction Manual".● For the CN8 connector, refer to section 13.3.1 of "MR-J4-_A_(-RJ) Servo Amplifier Instruction Manual".

The following shows an example of internal connection diagram of the point table method.

2. SIGNALS AND WIRING

(1) MR-J4-_A_-RJ 100 W or more

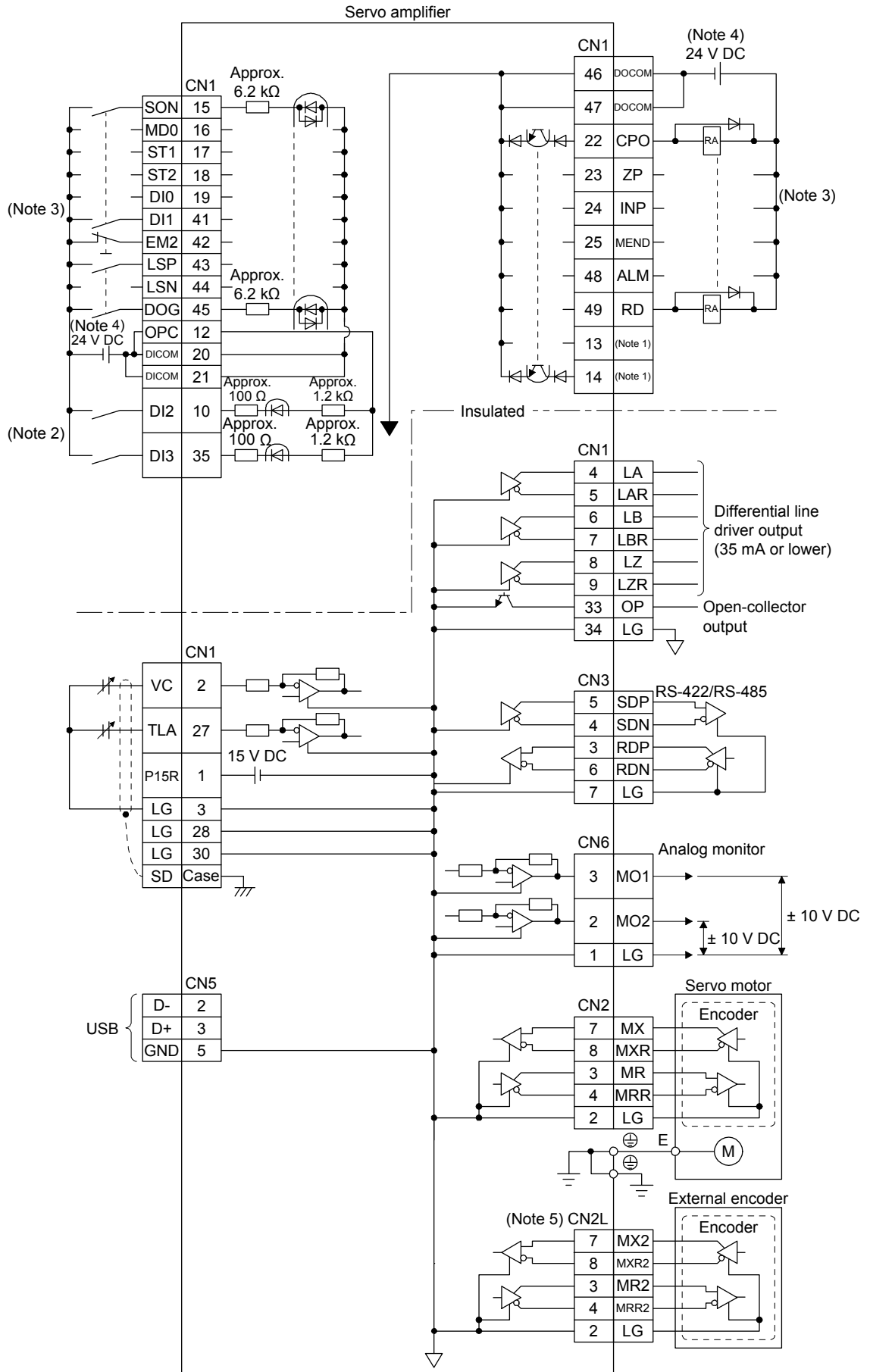

2. SIGNALS AND WIRING

- Note
1. Output signals are not assigned by default. Assign the output signals with [Pr. PD47] as necessary.
 2. Refer to section 9.1 for the connection of manual pulse generator.
 3. This diagram shows sink I/O interface. For source I/O interface, refer to section 3.9.3 of "MR-J4-_A_(-RJ) Servo Amplifier Instruction Manual".
 4. The illustration of the 24 V DC power supply is divided between input signal and output signal for convenience. However, they can be configured by one.
 5. For the connection with external encoders, refer to table 1.1 of "MR-J4-_A_(-RJ) Servo Amplifier Instruction Manual".

2. SIGNALS AND WIRING

(2) MR-J4-03A6-RJ

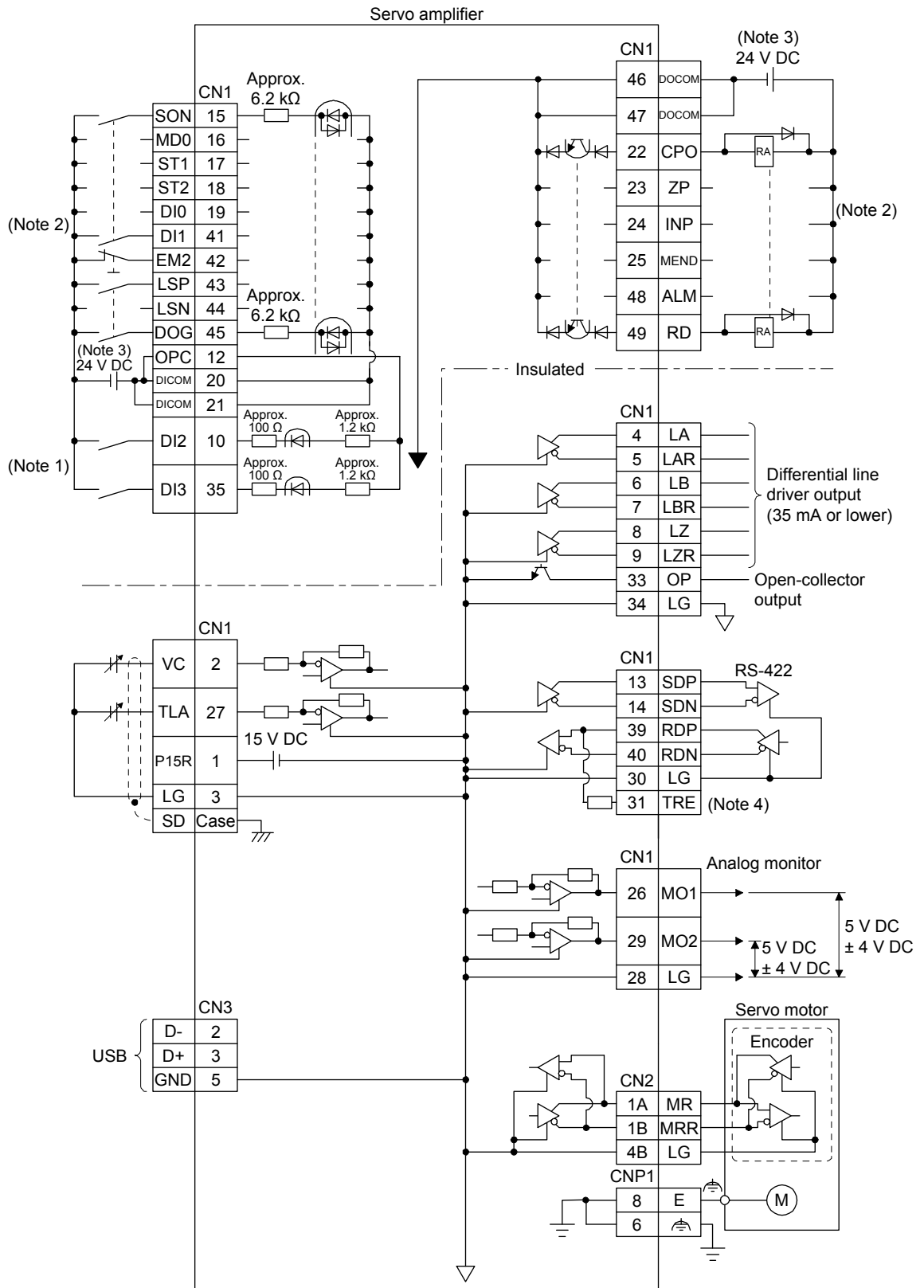

2. SIGNALS AND WIRING

- Note
1. Refer to section 9.1 for the connection of a manual pulse generator.
 2. This diagram shows sink I/O interface. For source I/O interface, refer to section 3.9.3 of "MR-J4-_A_(-RJ) Servo Amplifier Instruction Manual".
 3. The illustration of the 24 V DC power supply is divided between input signal and output signal for convenience. However, they can be configured by one. For 24 V DC power for I/O signal, use power other than 24 V DC power of servo amplifier control circuit power supply.
 4. To use the RS-422 communication function, connect between TRE and RDN of the final axis servo amplifier. (Refer to "MR-J4-_A_(-RJ) Servo Amplifier Instruction Manual" section 18.9.)

2. SIGNALS AND WIRING

2.6 Power-on sequence

POINT
<p>● The voltage of analog monitor output, output signal, etc. may be unstable at power-on.</p>

2.6.1 MR-J4-_A_-RJ 100 W or more

(1) Power-on procedure

- 1) Always use a magnetic contactor for the main circuit power supply wiring (L1/L2/L3) as shown in section 3.1 of "MR-J4-_A_-RJ Servo Amplifier Instruction Manual". Configure an external sequence to switch off the magnetic contactor as soon as an alarm occurs.
- 2) Switch on the control circuit power supply (L11 and L21) simultaneously with the main circuit power supply or before switching on the main circuit power supply. If the main circuit power supply is not on, the display shows the corresponding warning. However, by switching on the main circuit power supply, the warning disappears and the servo amplifier will operate properly.
- 3) The servo amplifier receives the SON (Servo-on) 4 s to 5 s after the main circuit power supply is switched on. Therefore, when SON (Servo-on) is switched on simultaneously with the main circuit power supply, the base circuit will switch on in about 4 s to 5 s, and the RD (Ready) will switch on in further about 5 ms, making the servo amplifier ready to operate. (Refer to (2) of this section.)
- 4) When RES (Reset) is switched on, the base circuit is shut off and the servo motor shaft coasts.

(2) Timing chart

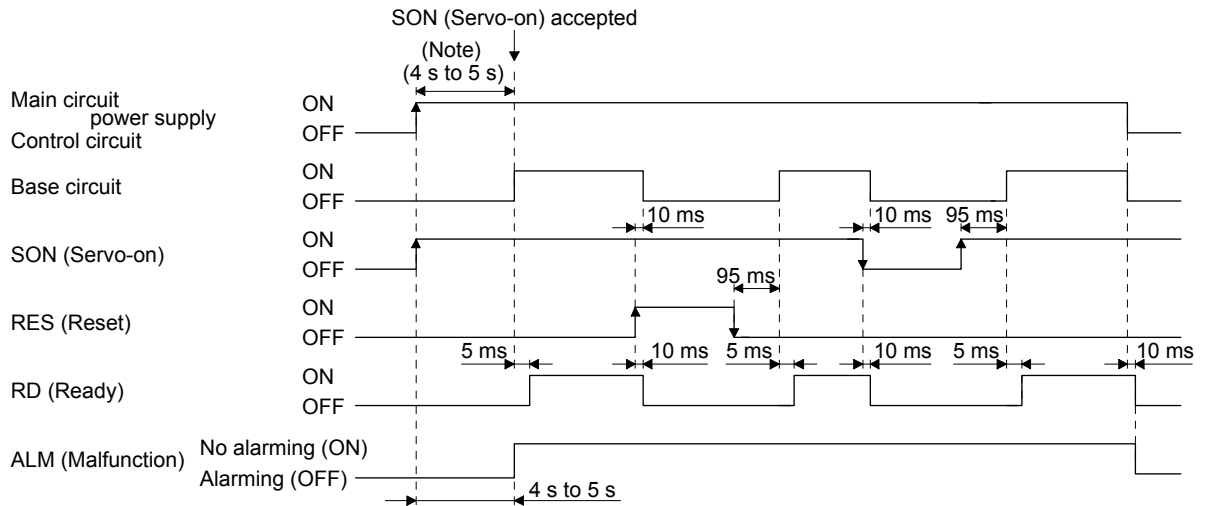

Note. The time will be longer during the magnetic pole detection of a linear servo motor and direct drive motor.

2. SIGNALS AND WIRING

2.6.2 MR-J4-03A6-RJ

(1) Power-on procedure

- 1) When wiring the power supply, always use a circuit protector for the power supply (24/PM). Configure up an external sequence so that the relay connected to PM turns off when an alarm occurs.
- 2) Switch on the control circuit power supply (24/0) simultaneously with the main circuit power supply (PM/0) or before switching on the main circuit power supply. If the main circuit power supply is not on, the display shows the corresponding warning. However, by switching on the main circuit power supply, the warning disappears and the servo amplifier will operate properly.
- 3) The servo amplifier receives the SON (Servo-on) within 4 s to 5 s after the main circuit power supply is switched on. Therefore, when SON (Servo-on) is switched on simultaneously with the main circuit power supply, the base circuit will switch on in about 4 s to 5 s, and the RD (Ready) will switch on in further about 5 ms, making the servo amplifier ready to operate. (Refer to (2) of this section.)
- 4) When RES (Reset) is switched on, the base circuit is shut off and the servo motor shaft coasts.

(2) Timing chart

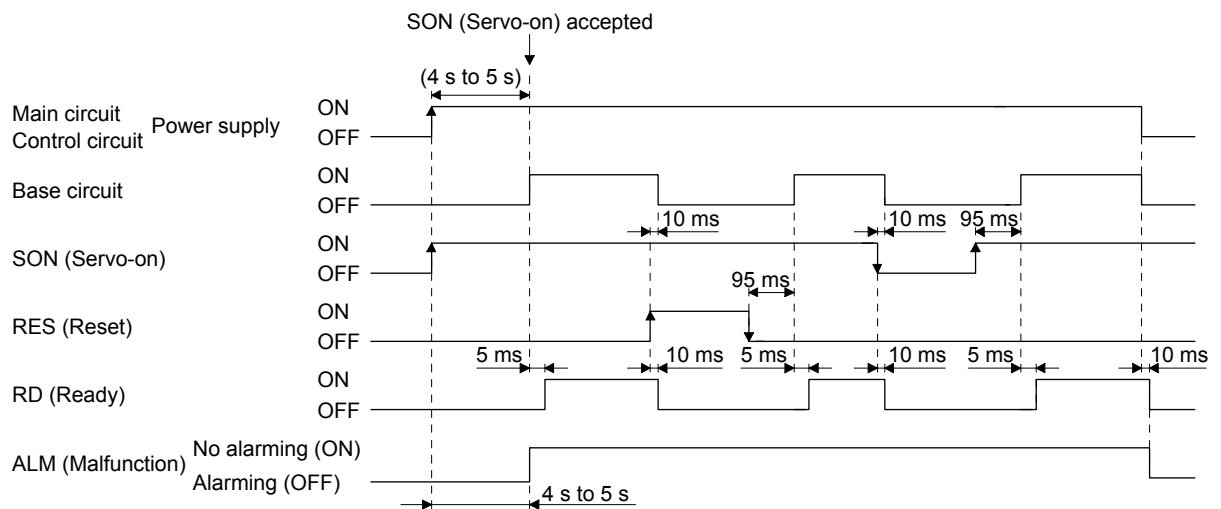

3. DISPLAY AND OPERATION SECTIONS

3. DISPLAY AND OPERATION SECTIONS

The following items are the same as MR-J4-_A_-RJ servo amplifiers. For details, refer to each section indicated in the detailed explanation field. "MR-J4-_A_" means "MR-J4-_A_(-RJ) Servo Amplifier Instruction Manual".

Item	Detailed explanation	
	MR-J4-_A_-RJ 100 W or more	MR-J4-03A6-RJ
Test operation mode	MR-J4-_A_ section 4.5.9	MR-J4-_A_ section 18.5.10

3.1 MR-J4-_A_-RJ 100 W or more

3.1.1 Display sequence

Press the "MODE" button once to shift to the next display mode. Refer to section 3.1.2 and later for the description of the corresponding display mode.

3. DISPLAY AND OPERATION SECTIONS

Display mode transition	Initial screen	Function	Reference
		Servo status display. For the point table method and program method, "PoS" is displayed at power-on. For the indexer method, "C" is displayed. (Note)	Section 3.1.2
		One-touch tuning Select this when performing the one-touch tuning.	MR-J4- A (-Rj) Servo Amplifier Instruction Manual section 6.2
		Sequence display, drive recorder enabled/disabled display, external I/O signal display, output signal (DO) forced output, test operation, software version display, VC automatic offset, servo motor series ID display, servo motor type ID display, servo motor encoder ID display, teaching function	Section 3.1.3
		Current alarm display, alarm history display and parameter error No./point table error No. display	Section 3.1.4
		Display and setting of point table data. The screen is displayed only in the point table method, and is not displayed in other control mode.	Section 3.1.5
		Display and setting of basic setting parameters.	Section 3.1.6
		Display and setting of gain/filter parameters.	
		Display and setting of extension setting parameters.	
		Display and setting of I/O setting parameters.	
		Display and setting of extension setting 2 parameters.	
		Display and setting of extension setting 3 parameters.	
		Display and setting of linear/DD motor setting parameters.	
		Display and setting of option setting parameters.	
		Display and setting of positioning control parameters.	

Note. When the axis name is set to the servo amplifier using MR Configurator2, the axis name is displayed and the servo status is then displayed.

3. DISPLAY AND OPERATION SECTIONS

3.1.2 Status display

The servo status during operation is shown on the 5-digit, 7-segment LED display. Press the "UP" or "DOWN" button to change display data as desired. When the required data is selected, the corresponding symbol is displayed. Press the "SET" button to display that data. At only power-on, however, data appears after the symbol of the status display selected in [Pr. PC36] has been shown for 2 s.

(1) Display transition

After selecting the status display mode with the "MODE" button, pressing the "UP" or "DOWN" button changes the display as shown below.

3. DISPLAY AND OPERATION SECTIONS

(a) Standard control mode (rotary servo motor)/DD motor control mode

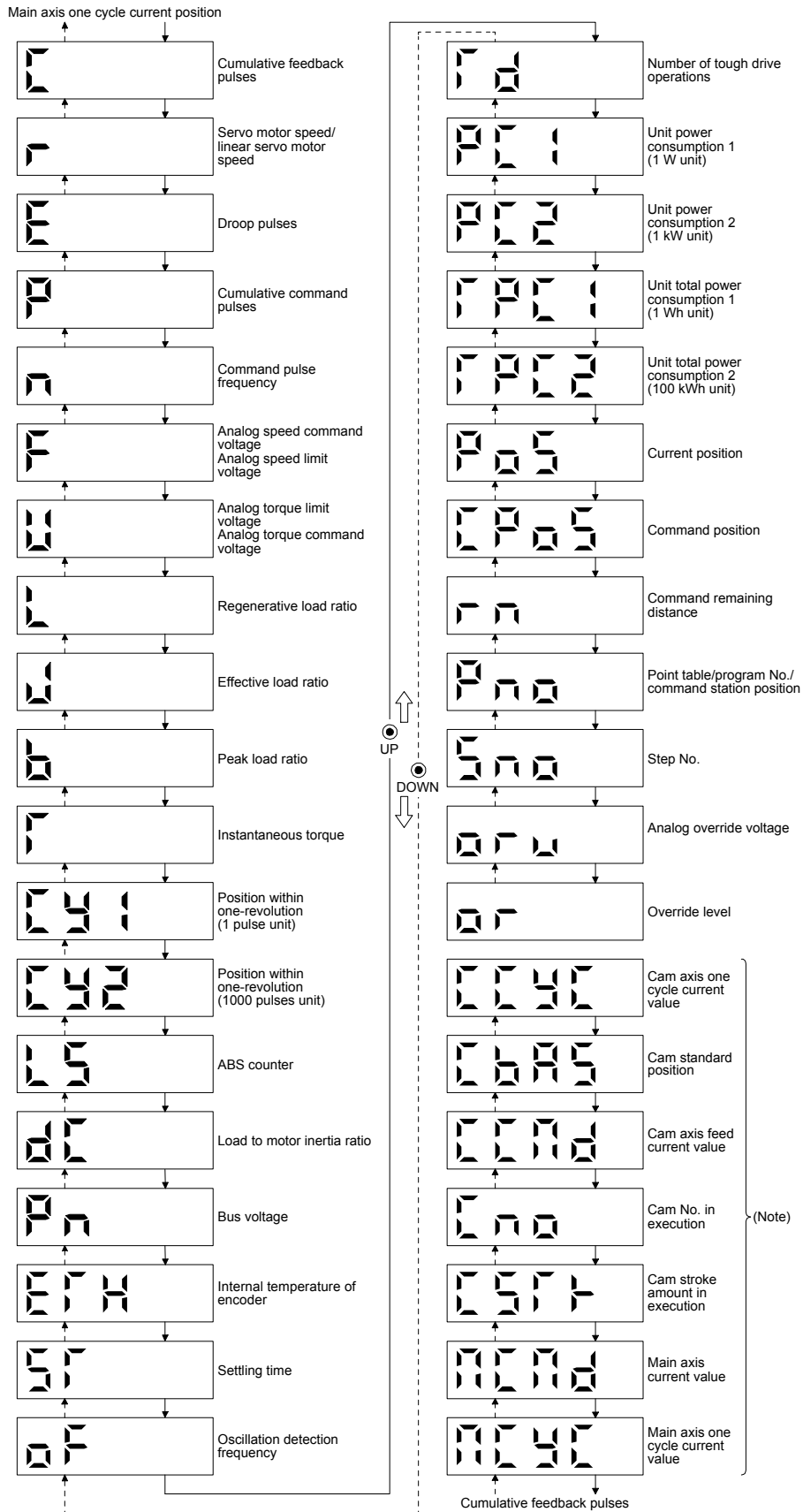

Note. Supported by servo amplifiers with software version B7 or later.

3. DISPLAY AND OPERATION SECTIONS

(b) Fully closed loop control mode

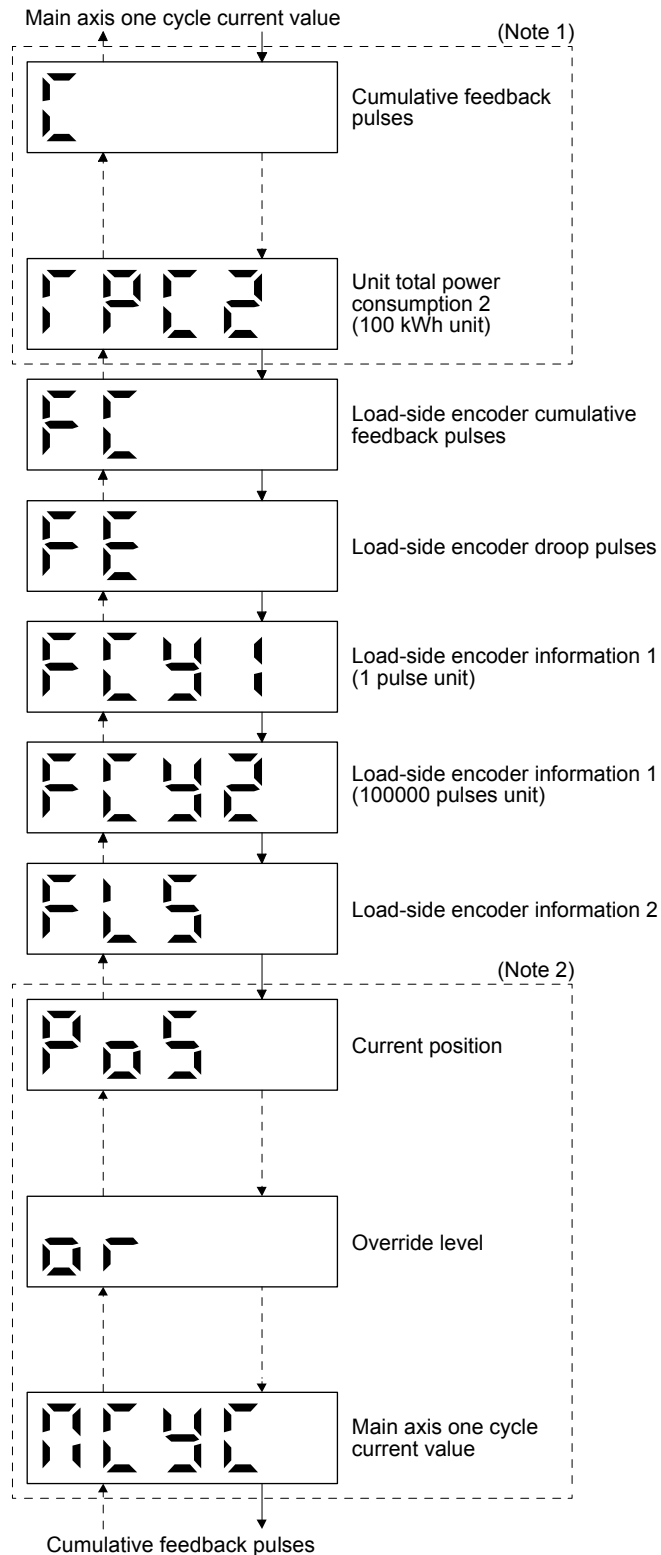

- Note 1. The displays in the frames are from the cumulative feedback pulses of positioning mode to unit total power consumption 2 (100 kWh unit) with some displays omitted.
- Note 2. The displays in the frames are from the current position of positioning mode to override level with some displays omitted.

3. DISPLAY AND OPERATION SECTIONS

(c) Linear servo motor control mode

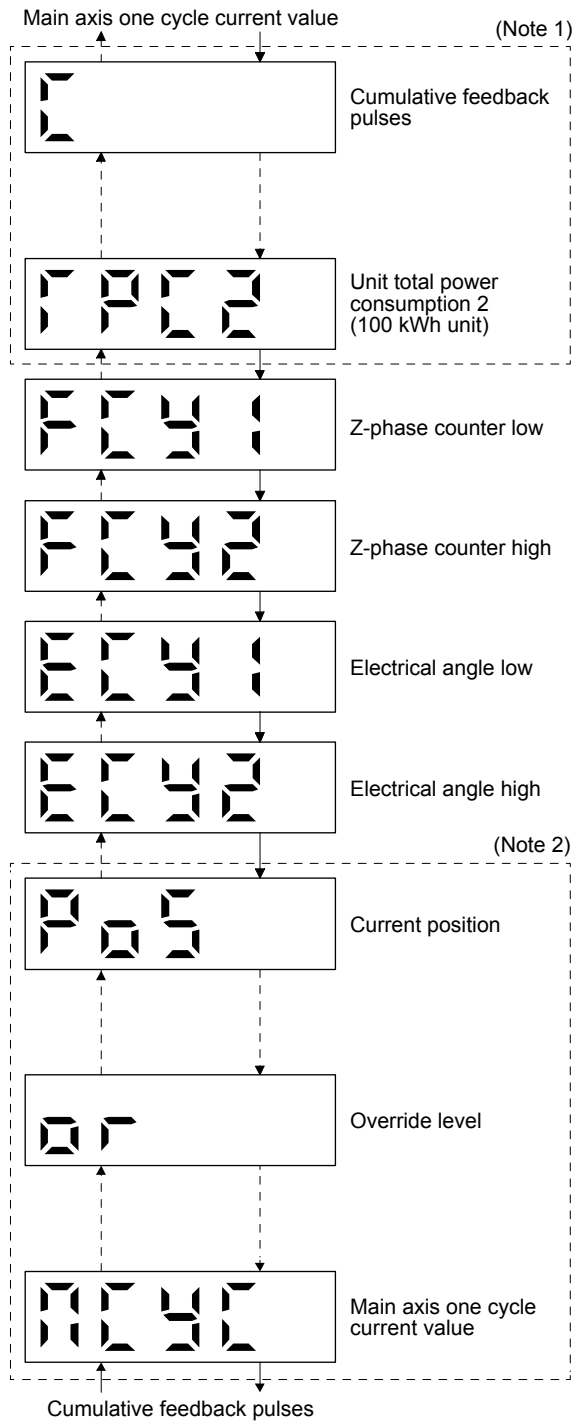

- Note 1. The displays in the frames are from the cumulative feedback pulses of positioning mode to unit total power consumption 2 (100 kWh unit) with some displays omitted.
- Note 2. The displays in the frames are from the current position of positioning mode to override level with some displays omitted.

3. DISPLAY AND OPERATION SECTIONS

(2) Status display list

The following table lists the servo statuses that may be shown.

Status display	Symbol	Unit	Description	Control mode (Note 1)			Operation mode (Note 3)			
				CP/BCD	CL	P/S	Standard	Full	Lin.	DD
Cumulative feedback pulses	C	pulse	Feedback pulses from the servo motor encoder are counted and displayed. The values in excess of ± 99999 can be counted. However, the counter shows only the lower five digits of the actual value since the servo amplifier display is five digits. Press the "SET" button to reset the display value to zero. The value of minus is indicated by the lit decimal points in the upper four digits.	○	○	○	○	○	○	○
Servo motor speed/ linear servo motor speed	r	r/min	The servo motor speed or linear servo motor speed is displayed. It is displayed rounding off 0.1 r/min (0.1 mm/s) unit.	○	○	○	○	○	○	○
Droop pulses	E	pulse	The number of droop pulses in the deviation counter are displayed. The decimal points in the upper four digits are lit for reverse rotation pulses. The values in excess of ± 99999 can be counted. However, the counter shows only the lower five digits of the actual value since the servo amplifier display is five digits. The number of pulses displayed is in the encoder pulse unit.	○	○	○	○	○	○	○
Cumulative command pulses	P	pulse	Not used with the positioning mode. "0" is always displayed.	/	/	/	/	/	/	/
Command pulse frequency	n	kpulse/s	Not used with the positioning mode. "0" is always displayed.	/	/	/	/	/	/	/
Analog speed command voltage Analog speed limit voltage	F	V	Not used with the positioning mode. An applied voltage to the CN1 connector is displayed.	/	/	/	/	/	/	/
Analog torque command voltage	U	V	Not used with the positioning mode. An applied voltage to the CN1 connector is displayed.	/	/	/	/	/	/	/
Analog torque limit voltage			Voltage of TLA (Analog torque limit) voltage is displayed.	○	○	○	○	○	○	○
Regenerative load ratio	L	%	The ratio of regenerative power to permissible regenerative power is displayed in %.	○	○	○	○	○	○	○
Effective load ratio	J	%	The continuous effective load current is displayed. The effective value in the past 15 s is displayed relative to the rated current of 100 %.	○	○	○	○	○	○	○
Peak load ratio	b	%	The maximum occurrence torque is displayed. The highest value in the past 15 s is displayed relative to the rated torque of 100 %.	○	○	○	○	○	○	○
Instantaneous torque	T	%	The instantaneous torque is displayed. The value of torque being occurred is displayed in real time considering a rated torque as 100%.	○	○	○	○	○	○	○
Position within one-revolution (1 pulse unit)	Cy1	pulse	Position within one revolution is displayed in encoder pulses. The values in excess of ± 99999 can be counted. However, the counter shows only the lower five digits of the actual value since the servo amplifier display is five digits. When the servo motor rotates in the CCW direction, the value is added.	○	○	○	○	○	○	○
Position within one-revolution (1000 pulses unit)	Cy2	1000 pulses	The within one-revolution position is displayed in 1000 pulse increments of the encoder. When the servo motor rotates in the CCW direction, the value is added.	○	○	○	○	○	○	○
ABS counter	LS	rev	The travel distance from the home position is displayed as multi-revolution counter value of the absolute position encoder in the absolute position detection system.	○	○	/	○	○	○	○
			The travel distance from the home position is displayed as load side multi-revolution counter value in the absolute position detection system.	/	/	○	○	○	○	○
Load to motor inertia ratio	dC	Multiplier	The estimated ratio of the load inertia moment to the servo motor shaft inertia moment is displayed.	○	○	○	○	○	○	○
Bus voltage	Pn	V	The voltage of main circuit converter (between P+ and N-) is displayed.	○	○	○	○	○	○	○
Encoder inside temperature	ETh	°C	Inside temperature of encoder detected by the encoder is displayed.	○	○	○	○	○	/	○

3. DISPLAY AND OPERATION SECTIONS

Status display	Symbol	Unit	Description	Control mode (Note 1)			Operation mode (Note 3)			
				CP/BCD	CL	PS	Standard	Full	Lin.	DD
Settling time	ST	ms	Settling time is displayed. When it exceeds 1000 ms, "1000" will be displayed.	○	○	○	○	○	○	○
Oscillation detection frequency	oF	Hz	Frequency at the time of oscillation detection is displayed.	○	○	○	○	○	○	○
Number of tough drive operations	Td	times	The number of tough drive functions activated is displayed.	○	○	○	○	○	○	○
Unit power consumption 1 (1 W unit)	PC1	W	Unit power consumption is displayed by increment of 1 W. Positive value indicates power running, and negative value indicates regeneration. The values in excess of ±99999 can be counted. However, the counter shows only the lower five digits of the actual value since the servo amplifier display is five digits.	○	○	○	○	○	○	○
Unit power consumption 2 (1 kW unit)	PC2	kW	Unit power consumption is displayed by increment of 1 kW. Positive value indicates power running, and negative value indicates regeneration.	○	○	○	○	○	○	○
Unit total power consumption 1 (1 Wh unit)	TPC1	Wh	Unit total power consumption is displayed by increment of 1 Wh. Positive value is cumulated during power running and negative value during regeneration. The values in excess of ±99999 can be counted. However, the counter shows only the lower five digits of the actual value since the servo amplifier display is five digits.	○	○	○	○	○	○	○
Unit total power consumption 2 (100 kWh unit)	TPC2	100 kWh	Unit total power consumption is displayed by increment of 100 kWh. Positive value is cumulated during power running and negative value during regeneration.	○	○	○	○	○	○	○
Load-side encoder Cumulative feedback pulses	FC	pulse	Feedback pulses from the load-side encoder are counted and displayed. The values in excess of ±99999 can be counted. However, the counter shows only the lower five digits of the actual value since the servo amplifier display is five digits. Press the "SET" button to reset the display value to zero. The value of minus is indicated by the lit decimal points in the upper four digits.	○	○			○		
Load-side encoder Droop pulses	FE	pulse	Droop pulses of the deviation counter between a load-side encoder and a command are displayed. When the count exceeds ±99999, it starts from 0. Negative value is indicated by the lit decimal points in the upper four digits. The display shows the average droop pulse value of 128-time sampling at the rate of 444 [μs].	○	○			○		
Load-side encoder information 1 (1 pulse unit)	FCy1	pulse	The Z-phase counter of a load-side encoder is displayed in the encoder pulse unit. For an incremental linear encoder, the Z-phase counter is displayed. The value is counted up from 0 based on the home position (reference mark). For an absolute position linear encoder, the encoder absolute position is displayed. When the count exceeds 99999, it starts from 0.	○	○			○		
Load-side encoder information 1 (100000 pulses unit)	FCy2	100000 pulses	The Z-phase counter of a load-side encoder is displayed by increments of 100000 pulses. For an incremental linear encoder, the Z-phase counter is displayed. The value is counted up from 0 based on the home position (reference mark). For an absolute position linear encoder, the encoder absolute position is displayed. When the count exceeds 99999, it starts from 0.	○	○			○		
Load-side encoder information 2	FL5	rev	When an incremental linear encoder is used as the load-side encoder, the display shows 0. When an absolute position linear encoder is used as the load-side encoder, the display shows 0. When a rotary encoder is used as the load-side encoder, the display shows the multi-revolution counter value of the encoder.	○	○			○		
Z-phase counter low	FCy1	pulse	The Z-phase counter is displayed in the encoder pulse unit. For an incremental linear encoder, the Z-phase counter is displayed. The value is counted up from 0 based on the home position (reference mark). For an absolute position linear encoder, the encoder absolute position is displayed. When the count exceeds 99999, it starts from 0.	○	○	○		○		

3. DISPLAY AND OPERATION SECTIONS

Status display	Symbol	Unit	Description	Control mode (Note 1)			Operation mode (Note 3)				
				CP/BCD	CL	PS	Standard	Full.	Lin.	DD	
Z-phase counter high	FCy2	100000 pulses	The Z-phase counter is displayed by increments of 100000 pulses. For an incremental linear encoder, the Z-phase counter is displayed. The value is counted up from 0 based on the home position (reference mark). For an absolute position linear encoder, the encoder absolute position is displayed. When the count exceeds 99999, it starts from 0.	○	○	○	/	/	/	○	/
Electrical angle low	ECy1	pulse	The servo motor electrical angle is displayed.	○	○	/	/	/	/	○	/
Electrical angle high	ECy2	100000 pulses	The servo motor electrical angle is displayed by increments of 100000 pulses.	○	○	/	/	/	/	○	/
Current position	PoS	10 ^{STM} μm 10 ^(STM-4) inch 10 ⁻³ degree pulse (Note 2)	When " _ _ 0 _ " (positioning display) is set in [Pr. PT26], the current position is displayed as machine home position is 0. When " _ _ 1 _ " (roll feed display) is set in [Pr. PT26], the actual current position is displayed as start position is 0. The values in excess of ±99999 can be counted. However, the counter shows only the lower five digits of the actual value since the servo amplifier display is five digits.	○	○	/	/	/	/	○	○
Command position	CPoS	10 ^{STM} μm 10 ^(STM-4) inch 10 ⁻³ degree pulse (Note 2)	When " _ _ 0 _ " (positioning display) is set in [Pr. PT26], the command current position is displayed as machine home position is 0. When " _ _ 1 _ " (roll feed display) is set in [Pr. PT26], turning on the start signal starts counting from 0 and a command current position to the target position is displayed in the automatic mode. The command positions of the selected point table are displayed at a stop. At the manual mode, the command positions of the selected point table are displayed. The values in excess of ±99999 can be counted. However, the counter shows only the lower five digits of the actual value since the servo amplifier display is five digits.	○	○	/	/	/	/	○	○
Command remaining distance	m	10 ^{STM} μm 10 ^(STM-4) inch 10 ⁻³ degree pulse (Note 2)	Indicates the remaining distance to the command position of the currently selected point table, program and station. The values in excess of ±99999 can be counted. However, the counter shows only the lower five digits of the actual value since the servo amplifier display is five digits.	○	○	○	○	○	○	○	○
Point table No./program No./command station position	Pno	/	For the point table method and program method, the point table and program No. currently being executed are displayed. The selected number is displayed during a temporary stop or manual operation. For the indexer method, the command next station position is displayed.	○	○	○	○	○	○	○	○
Step No.	Sno	/	The step No. of the program currently being executed is displayed. At a stop, 0 is displayed.	/	○	/	○	○	○	○	○
Analog override voltage	oru	V	The analog override voltage is displayed.	○	○	/	○	○	○	○	○
Override level	or	%	The setting value of the override is displayed. When the override is disabled, 100% is displayed.	○	○	○	○	○	○	○	○
Cam axis one cycle current value	CCyC	10 ^{STM} μm 10 ^(STM-4) inch 10 ⁻³ degree pulse (Note 4)	The current position in one cycle of CAM axis is displayed with the range of "0 to (cam axis one cycle length - 1)", the cam axis one cycle current value which is calculated from the travel distance inputted to the cam axis. When the simple cam function is disabled, 0 is always displayed. The values in excess of ±99999 can be counted. However, the counter shows only the lower five digits of the actual value since the servo amplifier display is five digits. Refer to section 12.1.8 for detecting point.	○	○	/	/	/	/	○	○
Cam standard position	CbAS	10 ^{STM} μm 10 ^(STM-4) inch 10 ⁻³ degree pulse (Note 2)	A feed current value which is the standard position of the cam operation is displayed. When the simple cam function is disabled, 0 is always displayed. The values in excess of ±99999 can be counted. However, the counter shows only the lower five digits of the actual value since the servo amplifier display is five digits. Refer to section 12.1.8 for detecting point.	○	○	/	/	/	/	○	○

3. DISPLAY AND OPERATION SECTIONS

Status display	Symbol	Unit	Description	Control mode (Note 1)			Operation mode (Note 3)			
				CP/BCD	CL	PS	Standard	Full.	Lin.	DD
Cam axis feed current value	CCMd	10 ^{STM} μm 10 ^(STM-4) inch 10 ⁻³ degree pulse (Note 2)	A feed current value during the cam axis control is displayed. When the simple cam function is disabled, 0 is always displayed. The values in excess of ±99999 can be counted. However, the counter shows only the lower five digits of the actual value since the servo amplifier display is five digits. Refer to section 12.1.8 for detecting point.	○	○	○	○	○	○	○
Cam No. in execution	Cno		Cam No. in execution is displayed. When the simple cam function is disabled, 0 is always displayed. Refer to section 12.1.8 for detecting point.	○	○	○	○	○	○	○
Cam stroke amount in execution	CSTK	10 ^{STM} μm 10 ^(STM-4) inch 10 ⁻³ degree pulse (Note 2)	Cam stroke amount in execution is displayed. When the simple cam function is disabled, 0 is always displayed. The values in excess of ±99999 can be counted. However, the counter shows only the lower five digits of the actual value since the servo amplifier display is five digits. Refer to section 12.1.8 for detecting point.	○	○	○	○	○	○	○
Main axis current value	MCMd	10 ^{STM} μm 10 ^(STM-4) inch 10 ⁻³ degree pulse (Note 4)	A current value of the input axis (synchronous encoder axis or servo input axis) is displayed. Unit is increment of input axis position. When the simple cam function is disabled, 0 is always displayed. The values in excess of ±99999 can be counted. However, the counter shows only the lower five digits of the actual value since the servo amplifier display is five digits. Refer to section 12.1.8 for detecting point.	○	○	○	○	○	○	○
Main axis one cycle current value	MCyC	10 ^{STM} μm 10 ^(STM-4) inch 10 ⁻³ degree pulse (Note 4)	The input travel amount of the input axis is displayed within the range of "0 and (cam axis one cycle length setting - 1)". Unit is an increment of cam axis one cycle. When the simple cam function is disabled, 0 is always displayed. The values in excess of ±99999 can be counted. However, the counter shows only the lower five digits of the actual value since the servo amplifier display is five digits. Refer to section 12.1.8 for detecting point.	○	○	○	○	○	○	○

Note 1. CP: Positioning mode (point table method)

BCD: Positioning mode (point table method in the BCD input positioning operation)

This method is available only when the MR-D01 unit is connected. Refer to chapter 12 for details.

CL: Positioning mode (program method)

PS: Positioning mode (indexer method)

2. The unit can be selected from μm/inch/degree/pulse with [Pr. PT01].

3. Standard: Standard (semi closed loop system) use of the rotary servo motor

Full.: Fully closed loop system use of the rotary servo motor

Lin.: Linear servo motor use

DD: Direct drive (DD) motor use

4. Depending on the setting of [Cam control data No. 30 Main shaft input axis selection], the parameters used to set the unit and feed length multiplication will change as follows. For details of each parameter, refer to section 7.2.9 and 12.1.7 (3).

Setting of [Cam control data No. 30]	Parameter for the unit setting	Parameter for the feed length multiplication setting
"0" or "1"	[Pr. PT01]	[Pr. PT03]
"2"	[Cam control data No. 14]	[Cam control data No. 14]

3. DISPLAY AND OPERATION SECTIONS

(3) Changing the status display screen

The status display item of the servo amplifier display shown at power-on can be changed by changing [Pr. PC36] settings. The item displayed in the initial status changes with the control mode as follows.

Control mode	Status display
Position	Cumulative feedback pulses
Position/speed	Cumulative feedback pulses/servo motor speed
Speed	Servo motor speed
Speed/torque	Servo motor speed/analog torque command voltage
Torque	Analog torque command voltage
Torque/position	Analog torque command voltage/cumulative feedback pulses
Positioning (point table method/program method)	Current position
Positioning (indexer method)	Cumulative feedback pulses

3. DISPLAY AND OPERATION SECTIONS

3.1.3 Diagnostic mode



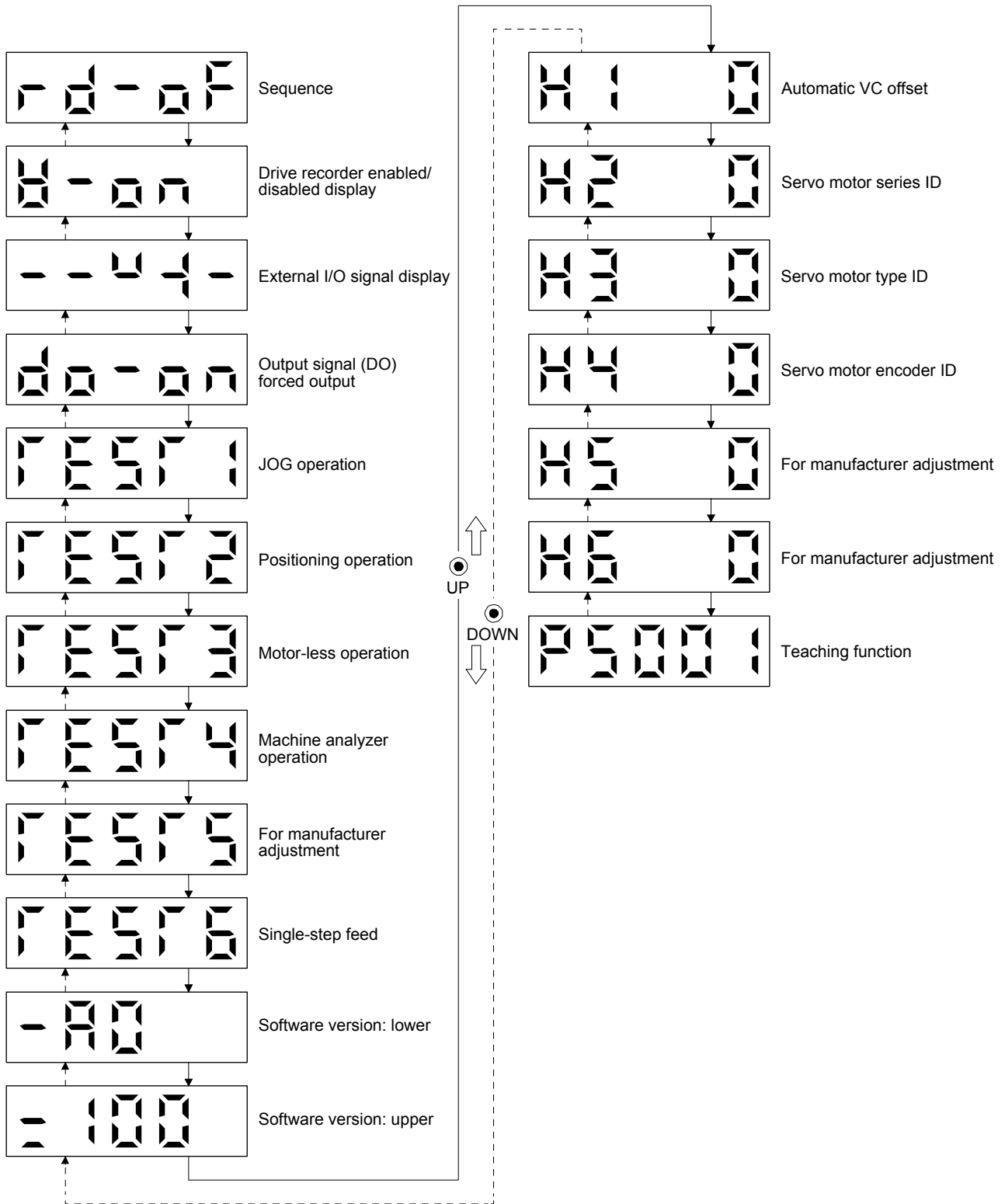

The display can show diagnosis contents. Press the "UP" or "DOWN" button to change display data as desired.

(1) Display transition

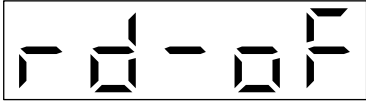
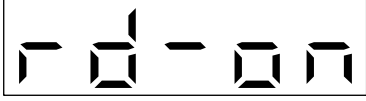

3. DISPLAY AND OPERATION SECTIONS

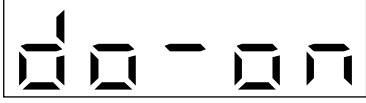
(2) Diagnosis display list

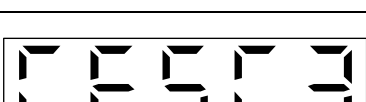
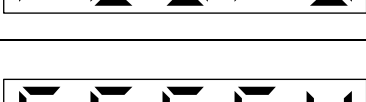
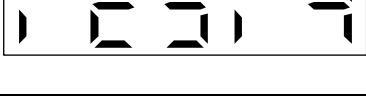
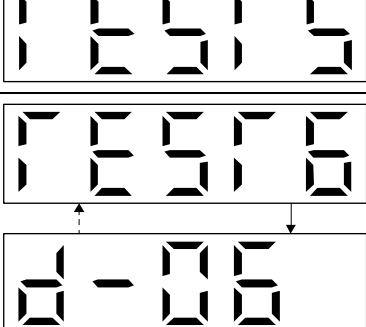
Name		Display	Description
Sequence			Not ready Indicates that the servo amplifier is being initialized or an alarm has occurred.
			Ready Indicates that the servo was switched on after completion of initialization and the servo amplifier is ready to operate.
Drive recorder enabled/disabled display			Drive recorder enabled When an alarm occurs in the status, the drive recorder will operate and write the status of occurrence.
			Drive recorder disabled The drive recorder will not operate on the following conditions. 1. You are using the graph function of MR Configurator2. 2. You are using the machine analyzer function. 3. [Pr. PF21] is set to "-1".
External I/O signal display		Refer to section 3.1.7.	This indicates the on/off status of external I/O signal. The upper segments correspond to the input signals and the lower segments to the output signals.
Output signal (DO) forced output			This allows digital output signal to be switched on/off forcibly. Refer to section 3.1.8 for details.
Test operation mode	JOG operation		JOG operation can be performed when there is no command from an external controller. For details, refer to section 4.5.9 (2) of "MR-J4-_A_(-RJ) Servo Amplifier Instruction Manual".
	Positioning operation		Positioning operation can be performed when there is no command from an external controller. MR Configurator2 is required to perform positioning operation. For details, refer to section 4.5.9 (3) of "MR-J4-_A_(-RJ) Servo Amplifier Instruction Manual".
	Motor-less operation		Without connecting the servo motor, output signals or status display can be provided in response to the input device as if the servo motor is actually running. For details, refer to section 4.5.9 (4) of "MR-J4-_A_(-RJ) Servo Amplifier Instruction Manual".
	Machine analyzer operation		Merely connecting the servo amplifier allows the resonance point of the mechanical system to be measured. MR Configurator2 is required to perform machine analyzer operation. For details, refer to section 11.7 of "MR-J4-_A_(-RJ) Servo Amplifier Instruction Manual".
	For manufacturer adjustment		This is for manufacturer adjustment.
	Single-step feed		This function is available only in the point table method and program method. When the positioning operation is executed in accordance with the point table or program set by MR Configurator2, the diagnosis display changes to "d-06" during single-step feed. For other control mode, the display does not change to "d-06". Refer to section 3.1.9 for details. The status will be displayed with the "MODE" button. The "UP" and "DOWN" buttons are disabled.

3. DISPLAY AND OPERATION SECTIONS

Name	Display	Description						
Software version - Lower		Indicates the version of the software.						
Software version - Upper		Indicates the system number of the software.						
Automatic VC offset (Note)		<p>If offset voltages in the analog circuits inside and outside the servo amplifier cause the servo motor setting speed not to be the designated value at VC or OVC of 0 V, a zero-adjustment of offset voltages will be automatically performed. When using the VC automatic offset, enable it in the following procedures.</p> <ol style="list-style-type: none"> 1) Press the "SET" once. 2) Set the number in the first digit to 1 with "UP"/"DOWN". 3) Press the "SET". <p>This function cannot be used if the input voltage of VC or OVC is -0.4 V or less, or +0.4 V or more. When the VC automatic offset is enabled, the following automatic offset voltage is applied according to the setting of [Pr. Po11].</p> <table border="1"> <thead> <tr> <th>Pr. Po11</th> <th>Offset voltage to be automatically adjusted</th> </tr> </thead> <tbody> <tr> <td>-- 0 --</td> <td>Offset voltage set with [Pr. PC37] (Servo amplifier side)</td> </tr> <tr> <td>-- 1 --</td> <td>Offset voltage set with [Pr. Po21] (MR-D01 side)</td> </tr> </tbody> </table>	Pr. Po11	Offset voltage to be automatically adjusted	-- 0 --	Offset voltage set with [Pr. PC37] (Servo amplifier side)	-- 1 --	Offset voltage set with [Pr. Po21] (MR-D01 side)
Pr. Po11	Offset voltage to be automatically adjusted							
-- 0 --	Offset voltage set with [Pr. PC37] (Servo amplifier side)							
-- 1 --	Offset voltage set with [Pr. Po21] (MR-D01 side)							
Servo motor series ID		<p>Push the "SET" button to show the series ID of the servo motor currently connected.</p> <p>For indication details, refer to app. 1 of "Servo Motor Instruction Manual (Vol. 3)".</p>						
Servo motor type ID		<p>Push the "SET" button to show the type ID of the servo motor currently connected.</p> <p>For indication details, refer to app. 1 of "Servo Motor Instruction Manual (Vol. 3)".</p>						
Servo motor encoder ID		<p>Push the "SET" button to show the encoder ID of the servo motor currently connected.</p> <p>For indication details, refer to app. 1 of "Servo Motor Instruction Manual (Vol. 3)".</p>						
For manufacturer adjustment		This is for manufacturer adjustment.						
For manufacturer adjustment		This is for manufacturer adjustment.						
Teaching function	Refer to section 3.1.10.	<p>After an operation travels to a target position (MEND (Travel completion) is turned on) with a JOG operation or manual pulse generator operation, pushing the "SET" button of the operation part or turning on TCH (Teach) will import position data. This function is available only in the point table method. For other control mode, the display remains the same.</p>						

Note. Even if VC automatic offset is performed and 0 V is inputted, the speed may not completely be the set value.

3. DISPLAY AND OPERATION SECTIONS

3.1.4 Alarm mode

The current alarm, past alarm history and parameter error are displayed. The lower 2 digits on the display indicate the alarm number that has occurred or the parameter number in error.

Name	Display (Note 1)	Description
Current alarm		Indicates no occurrence of an alarm.
		Indicates the occurrence of [AL. 33.1 Main circuit voltage error]. Flickers at alarm occurrence.
Alarm history		Indicates that the last alarm is [AL. 50.1 Thermal overload error 1 during operation].
		Indicates the second last alarm is [AL. 33.1 Main circuit voltage error].
		Indicates the third last alarm is [AL. 10.1 Voltage drop in the control circuit power].
		Indicates that there is no tenth alarm in the past.
		Indicates that there is no eleventh alarm in the past.
		Indicates that there is no twelfth alarm in the past.
		Indicates that there is no sixteenth alarm in the past.
Parameter error No./point table error No. (Note 2)		This indicates no occurrence of [AL. 37 Parameter error].
		The data content error of [Pr. PA12 Reverse rotation torque limit].
		The value of the point table is over the setting range. The error point table No. (intermediate digit "2") and item (lower digit "d") are displayed. The following shows the items. P: position data, d: motor speed, A: acceleration time constant, b: deceleration time constant, n: dwell, H: auxiliary function, M: M code

- Note 1. If a parameter error and point table error occur simultaneously, the display shows the parameter error.
2. The display shows only when the current alarm is [AL. 37 Parameter error].

3. DISPLAY AND OPERATION SECTIONS

The following is additional information of alarm occurrence.

- (1) Any mode screen displays the current alarm.
- (2) Even during alarm occurrence, the other screen can be viewed by pressing the button in the operation area. At this time, the decimal point in the fourth digit remains flickering.
- (3) For any alarm, remove its cause and clear it in any of the following methods. (Refer to chapter 8 for the alarms that can be cleared.)
 - (a) Switch power off, then on.
 - (b) Push the "SET" button on the current alarm screen.
 - (c) Turn on RES (Reset).
- (4) Use [Pr. PC18] to clear the alarm history.
- (5) Push "UP" or "DOWN" to move to the next history.

3. DISPLAY AND OPERATION SECTIONS

3.1.5 Point table setting

You can set the target position, servo motor speed, acceleration time constant, deceleration time constant, dwell, auxiliary function and M code.

(1) Display transition

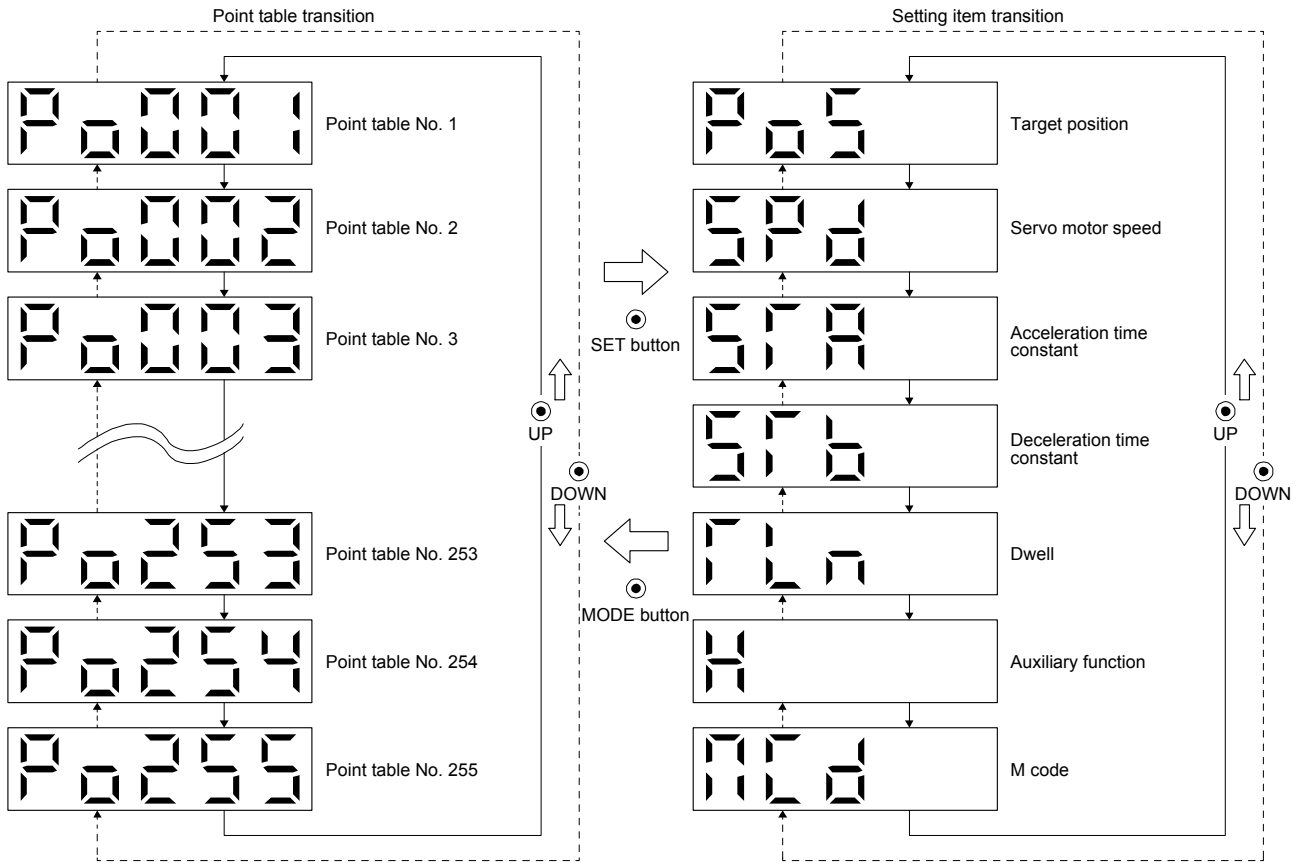

3. DISPLAY AND OPERATION SECTIONS

(2) Setting list

The following table indicates the point table settings that may be displayed.

Status display	Symbol	Unit	Description	Indication range
Point table No.	Po001		Specify the point table to set the target position, servo motor speed, acceleration time constant, deceleration time constant, dwell, auxiliary function and M code.	1 to 255
Target position	PoS	10 ^{STM} μm 10 ^(STM-4) inch 10 ⁻³ degree pulse (Note 1)	Set the travel distance.	-999999 to 999999
Servo motor speed	SPd	r/min mm/s (Note 2)	Set the command speed of the servo motor for execution of positioning. The setting value must be within the permissible speed of the servo motor used. If a value equal to or larger than the permissible speed is set, the value is clamped at the permissible speed.	0 to Permissible speed
Acceleration time constant	STA	ms	Set a time until the servo motor rotates at the rated speed.	0 to 20000
Deceleration time constant	STb	ms	Set a time from when the servo motor rotates at the rated speed until when the motor stops.	0 to 20000
Dwell	TLn	ms	This function is enabled when you select the point table by input signal. To disable the dwell, set "0" or "2" to the auxiliary function. To perform varying-speed operation, set "1", "3", "8", "9", "10", or "11" to the auxiliary function and 0 to the dwell. When the dwell is set, the position command of the selected point table is completed. After the set dwell has elapsed, start the position command of the next point table.	0 to 20000
Auxiliary function	H		This function is enabled when you select the point table by input signal. (1) When using this point table under the absolute value command method 0: Automatic operation is performed in accordance with a single point table selected. 1: Executes automatic continuous operation without stopping for the next point table. 8: Automatic continuous operation is performed to the point table selected at start-up. 9: Automatic continuous operation is performed to point table No. 1. (2) When using this point table under the incremental value command method 2: Automatic operation is performed in accordance with a single point table selected. 3: Executes automatic continuous operation without stopping for the next point table. 10: Automatic continuous operation is performed to the point table selected at start-up. 11: Automatic continuous operation is performed to point table No. 1. When a different rotation direction is set, smoothing zero (command output) is confirmed and then the rotation direction is reversed. When "1" or "3" is set to the point table No. 255, [AL. 61] will occur at the time of point table execution.	0 to 3, 8 to 11
M code	MCd		This is the code output at the completion of positioning. Outputs the first digit and the second digit of the M code in 4-bit binary respectively.	0 to 99

- Note 1. The unit can be selected from μm/inch/degree/pulse with [Pr. PT01].
2. The unit will be "mm/s" for the linear servo motor control mode.

3. DISPLAY AND OPERATION SECTIONS

(3) Operation method

POINT	<p>● After changing and defining the setting values of the specified point table, the defined setting values of the point table are displayed. After defining the values, pressing the "MODE" button for 2 s or more to discard the changed setting values, and the previous setting values are displayed. Keep pressing the "UP" or "DOWN" button to continuously change the most significant digit of the setting values.</p>
-------	---

(a) Setting of 5 or less digits

The following example is the operation method at power-on to set "1" to the auxiliary function of the point table No. 1.

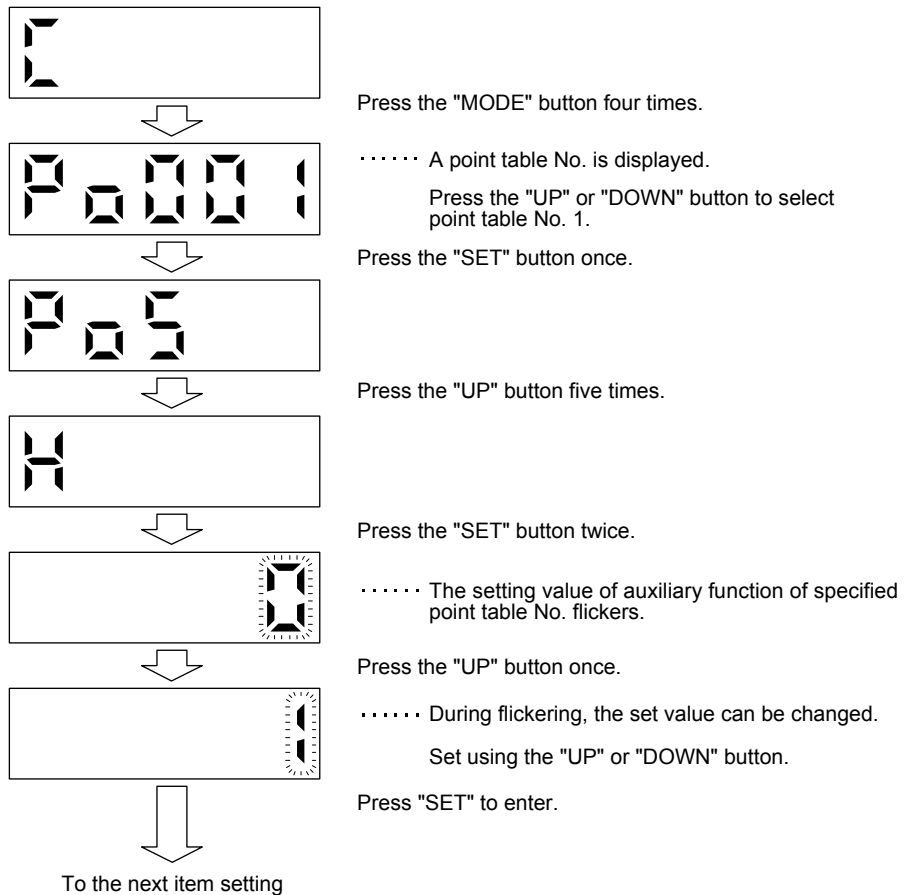

Press the "MODE" button four times.

..... A point table No. is displayed.

Press the "UP" or "DOWN" button to select point table No. 1.

Press the "SET" button once.

Press the "UP" button five times.

Press the "SET" button twice.

..... The setting value of auxiliary function of specified point table No. flickers.

Press the "UP" button once.

..... During flickering, the set value can be changed.

Set using the "UP" or "DOWN" button.

Press "SET" to enter.

Press the "UP" or "DOWN" button to switch to other item of the same point table No.

Press the "MODE" button to switch to the next point table No.

3. DISPLAY AND OPERATION SECTIONS

(b) Setting of 6 or more digits

The following example is the operation method to change the position data of the point table No. 1 to "123456".

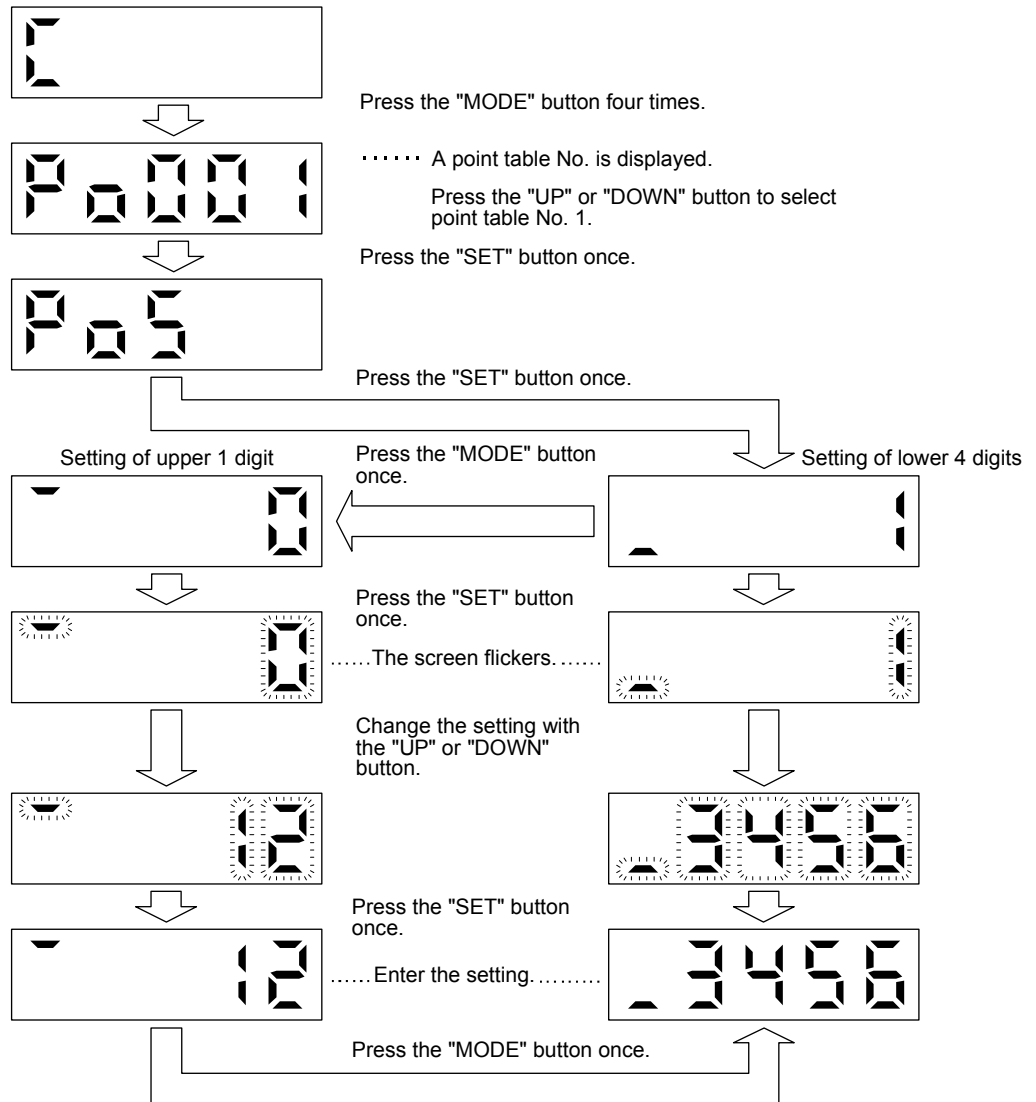

3. DISPLAY AND OPERATION SECTIONS

3.1.6 Parameter mode

(1) Parameter mode transition

After selecting the corresponding parameter mode with the "MODE" button, pressing the "UP" or "DOWN" button changes the display as shown below.

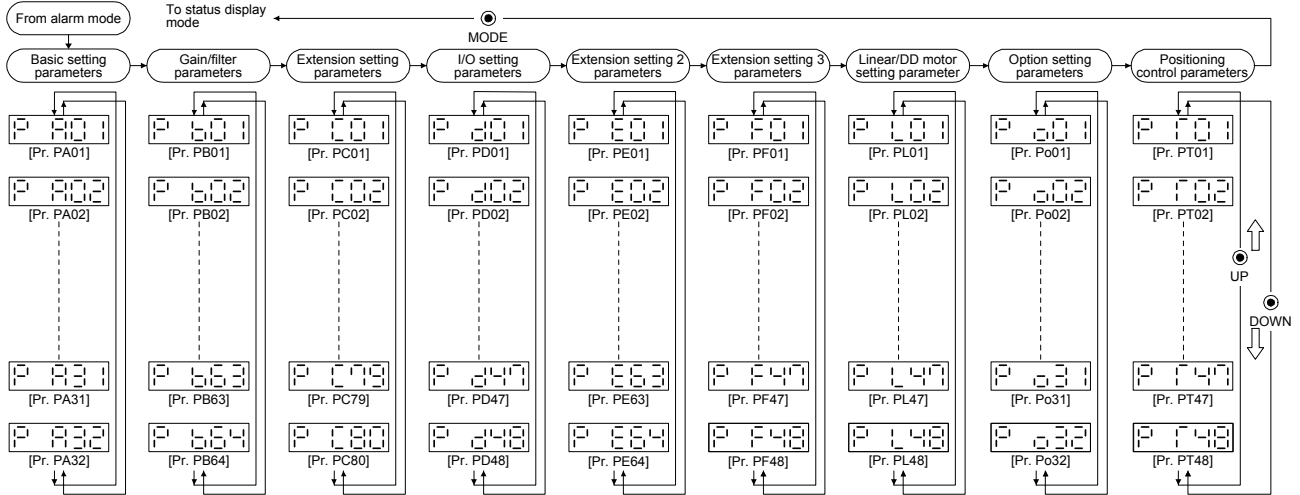

(2) Operation method

(a) Parameters of 5 or less digits

The following example shows the operation procedure performed after power-on to change the control mode to the positioning mode (point table method) with [Pr. PA01 Operation mode]. Press "MODE" to switch to the basic setting parameter screen.

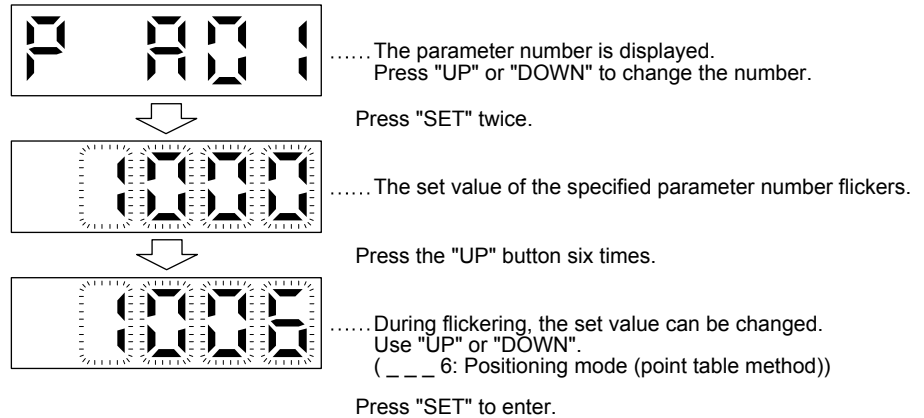

To shift to the next parameter, press the "UP" or "DOWN" button.

When changing the [Pr. PA01] setting, change its setting value, then switch power off once and switch it on again to enable the new value.

3. DISPLAY AND OPERATION SECTIONS

(b) Parameters of 6 or more digits

The following example gives the operation procedure to change the electronic gear numerator to "123456" with [Pr. PA06 Electronic gear numerator].

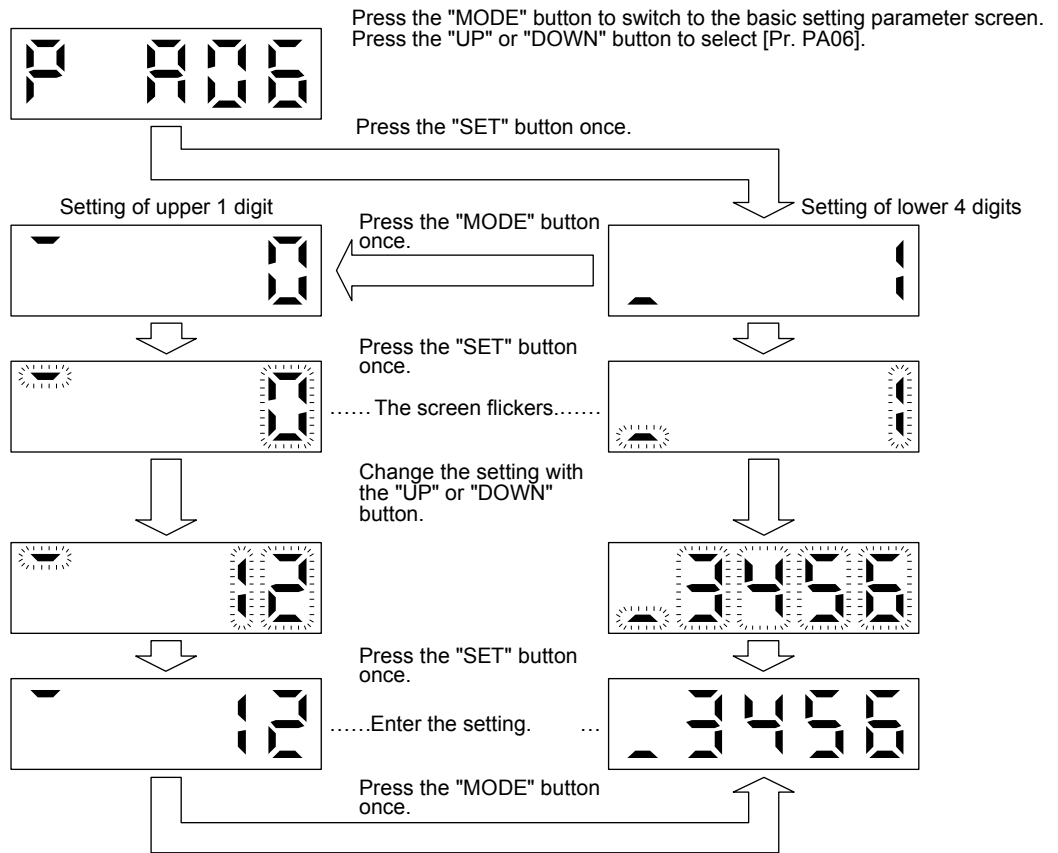

3. DISPLAY AND OPERATION SECTIONS

3.1.7 External I/O signal display

POINT

● The I/O signal settings can be changed using the I/O setting parameters [Pr. PD04] to [Pr. PD28].

The on/off states of the digital I/O signals connected to the servo amplifier can be confirmed.

(1) Operation

The display screen at power-on. Using the "MODE" button, display the diagnostic screen.

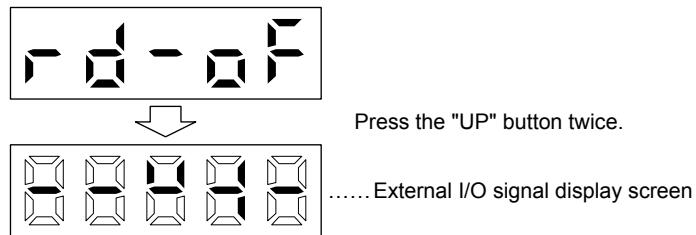

(2) Display definition

The 7-segment LED segments and CN1 connector pins correspond as shown below.

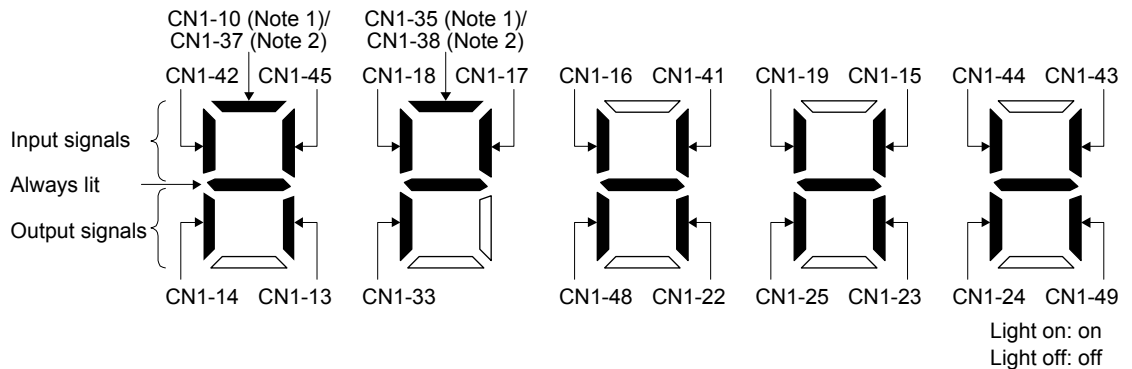

- Note 1. This pin is available with servo amplifiers having software version B3 or later, and manufactured in November 2014 or later.
- Note 2. This pin is available with servo amplifiers having software version B7 or later, and manufactured in January 2015 or later.

The LED segment corresponding to the pin is lit to indicate on, and is extinguished to indicate off. For each pin signal in control modes, refer to section 2.2 (1).

3. DISPLAY AND OPERATION SECTIONS

3.1.8 Output signal (DO) forced output

POINT
<p>● When the servo system is used in a vertical lift application, turning on MBR (Electromagnetic brake interlock) by the DO forced output after assigning it to connector CN1 will release the electromagnetic brake, causing a drop. Take drop preventive measures on the machine side.</p>

Output signals can be switched on/off forcibly independently of the servo status. This function can be used for output signal wiring check, etc. This operation must be performed in the servo off state by turning off SON (Servo-on).

The display screen at power-on. Using the "MODE" button, display the diagnostic screen.

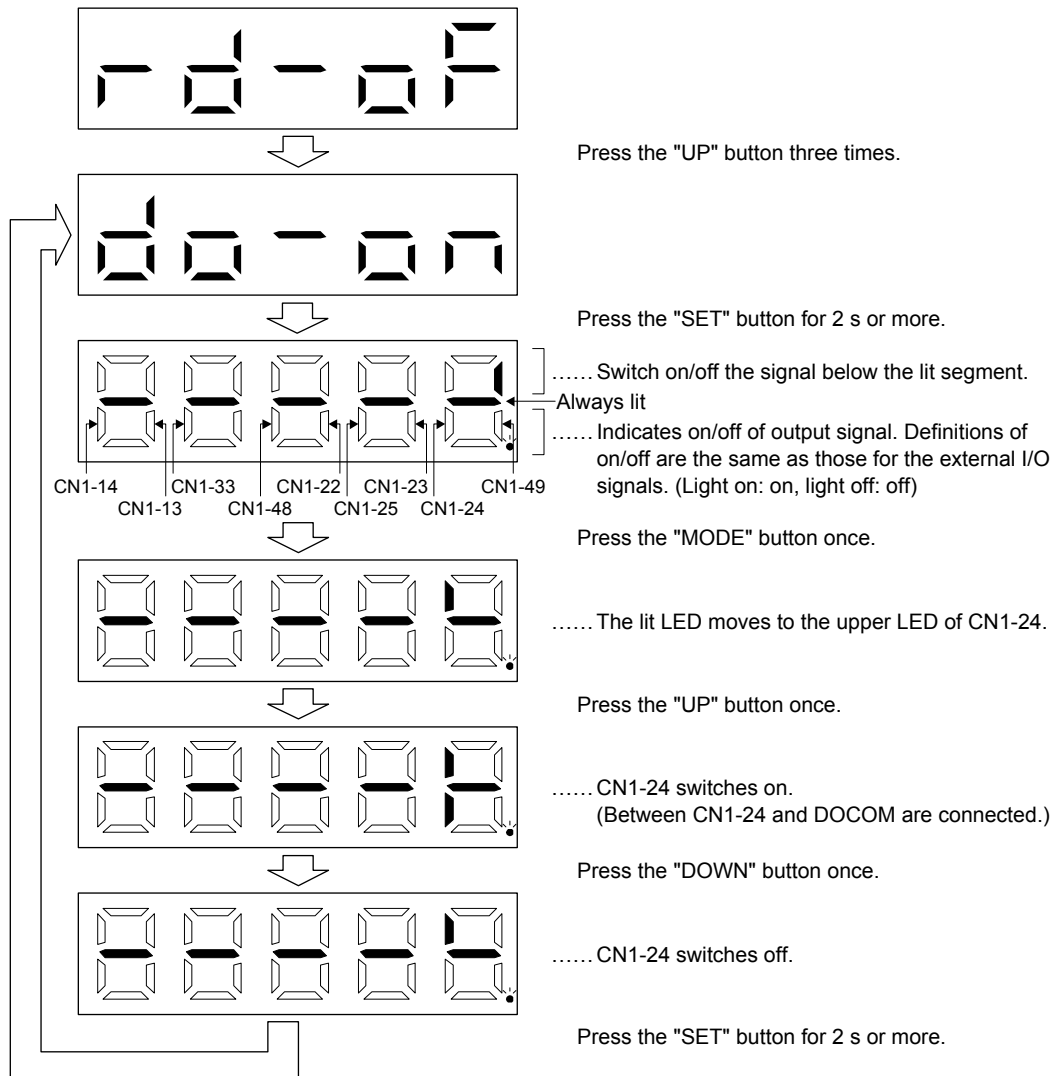

3. DISPLAY AND OPERATION SECTIONS

3.1.9 Single-Step feed



CAUTION

- The test operation mode is designed for checking servo operation. Do not use it for actual operation.
- If the servo motor operates unexpectedly, use EM2 (Forced stop 2) to stop it.

POINT

- MR Configurator2 is required to perform single-step feed.
- Test operation cannot be performed if SON (Servo-on) is not turned off.

The positioning operation can be performed in accordance with the point table No. or program No. set by MR Configurator2.

Select the test operation/single-step feed by the menu of MR Configurator2. When the single-step feed window is displayed, input the following items and operate.

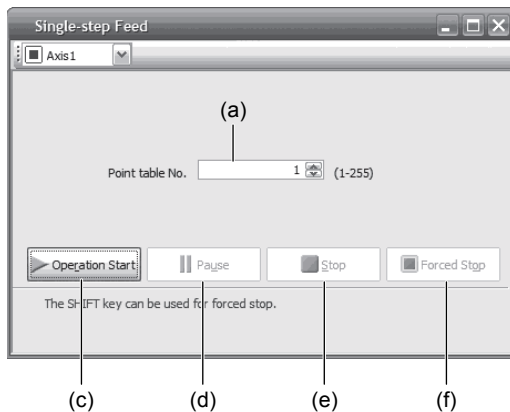

Point table operation

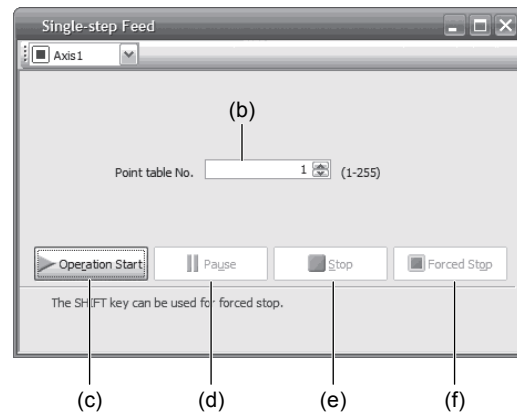

Program operation

- (1) Point table No. or program No. setting
Input a point table No. into the input box (a) "Point table No.", or a program No. into the input box (b) "Program No."
- (2) Forward/reverse the servo motor
Click "Operation Start" (c) to rotate the servo motor.
- (3) Pause the servo motor
Click "Pause" (d) to temporarily stop the servo motor.
While the servo motor is temporarily stopped, click "Operation Start" (c) to restart the rotation by the amount of the remaining travel distance.
While the servo motor is temporarily stopped, click "Stop" (e) to clear the remaining travel distance.
- (4) Stop the servo motor
Click "Stop" (e) to stop the servo motor. At this time, the remaining travel distance is cleared. Click "Operation Start" (c) to restart the rotation.

3. DISPLAY AND OPERATION SECTIONS

(5) Forced stop of the servo motor software

Click "Forced Stop" (f) to make an instantaneous stop. When "Forced Stop" is enabled, the servo motor does not drive even if "Operation Start" is clicked. Click "Forced Stop" again to enable "Operation Start" to be clicked.

(6) Switch to the normal operation mode

Before switching from the test operation mode to the normal operation mode, turn off the servo amplifier.

3. DISPLAY AND OPERATION SECTIONS

3.1.10 Teaching function

After an operation travels to a target position (MEND (Travel completion) is turned on) with a JOG operation or manual pulse generator operation, pushing the "SET" button of the operation part or turning on TCH (Teach) will import position data. This function is available only in the point table method. For other control mode, the display remains the same.

(1) Teaching preparation



Teaching setting initial screen

Press the "SET" button for approximately 2 s to switch to the teaching setting mode.

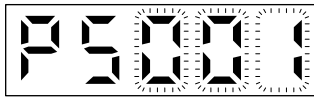

When the lower three digits flicker, press the "UP" or "DOWN" button to select the point table.

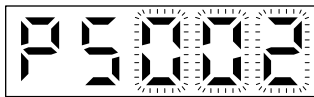

When the lower three digits flicker, press the "SET" button to complete the teaching setting preparation. The upper two digits on the display will flicker on completion of proper preparation

(2) Position data setting method

After an operation travels to a target position (MEND (Travel completion) is turned on) with a JOG operation or manual pulse generator operation, pushing the "SET" button of the operation part or turning on TCH (Teach) will set the positioning address as position data.



When the upper two digits flicker, the current position is written to the selected point table by pressing the "SET" button.



When the upper two digits or the lower two digits flicker, the display returns to the teaching setting initial screen by pressing the "MODE" button.

The following shows the conditions for when the teaching function operates.

- (a) When the "positioning command method" of [Pr. PT01] is set to absolute value command method (___0)
- (b) Home position return completion (ZP (Home position return completion) is turned on)
- (c) While the servo motor is stopped (command output = 0, MEND (Travel completion) is turned on)

3. DISPLAY AND OPERATION SECTIONS

3.2 MR-J4-03A6-RJ

3.2.1 Display flowchart

Press the "MODE" button once to shift to the next display mode. Refer to section 3.2.2 and later for the description of the corresponding display mode.

Display mode transition	Initial screen	Function	Reference
		Servo status display. For the point table method and program method, "PSL" is displayed at power-on. For the indexer method, "CL" is displayed. (Note)	Section 3.1.2
		One-touch tuning Select this when performing the one-touch tuning.	MR-J4-_A_(-RJ) Servo Amplifier Instruction Manual section 6.2 Section 18.5.4
		Sequence display, drive recorder enabled/disabled display, external I/O signal display, output signal (DO) forced output, test operation, software version display, VC automatic offset, servo motor series ID display, servo motor type ID display, servo motor encoder ID display, teaching function	Section 3.2.3
		Current alarm display, alarm history display, and parameter error No./point table error No. display	Section 3.2.4
		Display and setting of point table data. This is displayed only in the point table method, not in other control modes.	Section 3.2.5
		Display and setting of basic setting parameters.	Section 3.2.6
		Display and setting of gain/filter parameters.	
		Display and setting of extension setting parameters.	
		Display and setting of I/O setting parameters.	
		Display and setting of extension setting 2 parameters.	
		Display and setting of extension setting 3 parameters.	
		Display and setting of option setting parameters.	
	Display and setting of positioning control parameters.		

Note. When the axis name is set to the servo amplifier using MR Configurator2, the servo status is displayed after the axis name is displayed.

3. DISPLAY AND OPERATION SECTIONS

3.2.2 Status display mode

The servo status during operation is shown on the 3-digit, 7-segment LED display. Press the "UP" or "DOWN" button to change the display data as desired. When a servo status is selected, the corresponding symbol is displayed. Press the "SET" button to display its data. However, only when the power is turned on, the data will be displayed after the status symbol selected with [Pr. PC36] is displayed for 2 s.

(1) Display transition

After selecting the status display mode with the "MODE" button, pressing the "UP" or "DOWN" button changes the display as follows:

3. DISPLAY AND OPERATION SECTIONS

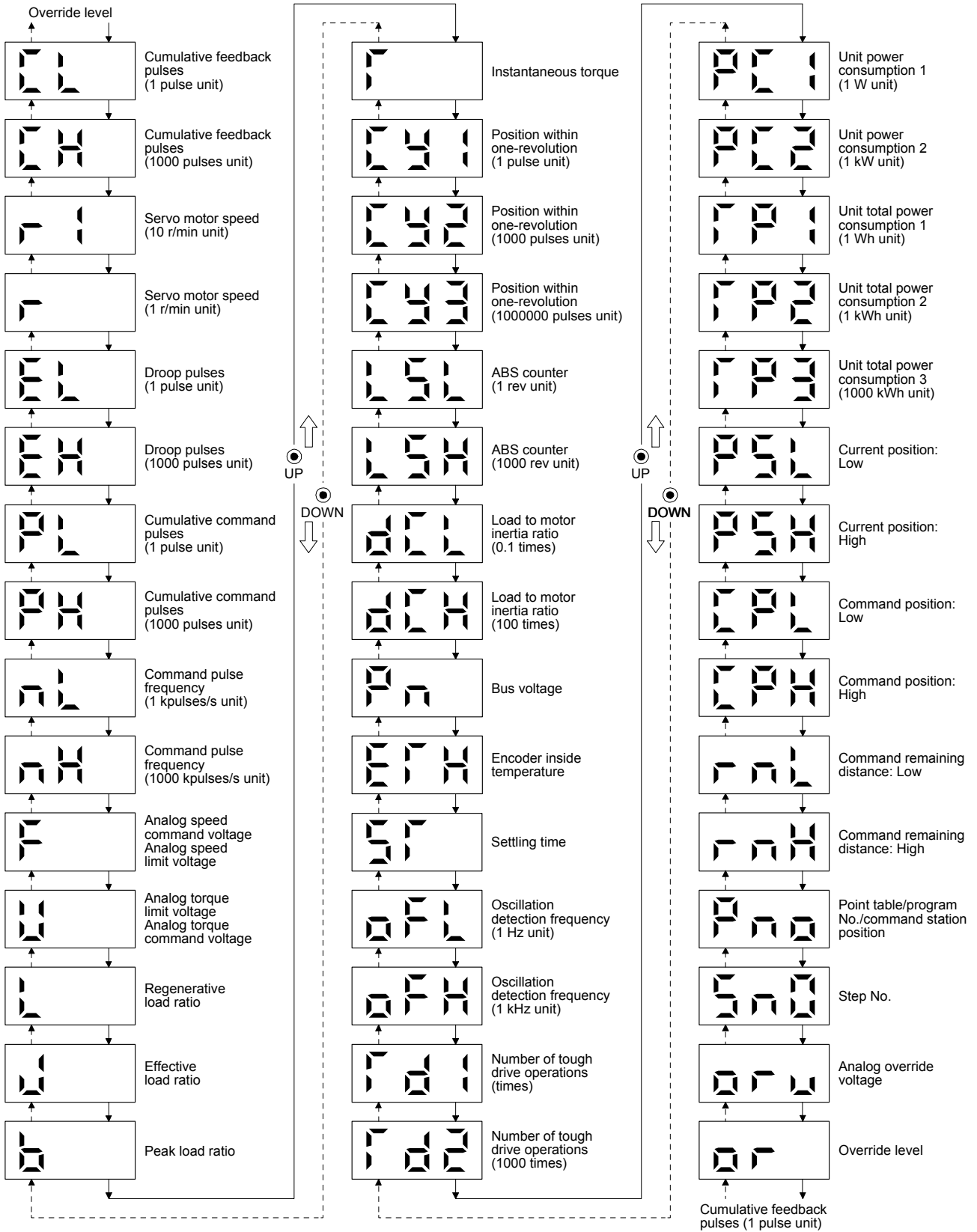

3. DISPLAY AND OPERATION SECTIONS

(2) Status display list

The following table lists the servo statuses that may be shown.

Status display	Symbol	Unit	Description	Control mode (Note 1)		
				CP	CL	PS
Cumulative feedback pulses (1 pulse unit)	CL	pulse	Feedback pulses from the servo motor encoder are counted and displayed. When the count exceeds ± 999 , it starts from 0. Negative value is indicated by the lit decimal points in the upper two digits. Press the "SET" button to reset the display value to zero.	○	○	○
Cumulative feedback pulses (1000 pulses unit)	Ch	1000 pulses	The internal counter subtracts 500000000 when the number exceeds 2000000000. The internal counter adds 500000000 when the number exceeds -2000000000.	○	○	○
Servo motor speed (10 r/min unit)	r1	10 r/min	The servo motor speed is displayed. Negative value is indicated by the lit decimal points in the upper two digits. Displayed in increments of 10 r/min.	○	○	○
Servo motor speed (1 r/min unit)	r	r/min	The servo motor speed is displayed. Negative value is indicated by the lit decimal points in the upper two digits.	○	○	○
Droop pulses (1 pulse unit)	EL	pulse	The number of droop pulses in the deviation counter is displayed. When the count exceeds ± 999 , it starts from 0.	○	○	○
Droop pulses (1000 pulses unit)	Eh	1000 pulses	The value displayed is not multiplied by the electronic gear (CMX/CDV). Negative value is indicated by the lit decimal points in the upper two digits.	○	○	○
Cumulative command pulses (1 pulse unit)	PL	pulse	Not used with the positioning mode. "0" is always displayed.			
Cumulative command pulses (1000 pulses unit)	Ph	1000 pulses				
Command pulse frequency (1 kpulses/s unit)	nL	kpulse/s	Not used with the positioning mode. "0" is always displayed.			
Command pulse frequency (1000 kpulses/s unit)	nh	1000 kpulses/s				
Analog speed command voltage Analog speed limit voltage	F	V	Not used with the positioning mode. An applied voltage to the CN1 connector is displayed.			
Analog torque command voltage Analog torque limit voltage	U	V	Voltage of TLA (Analog torque limit) is displayed.			
Regenerative load ratio	L	%	The ratio of regenerative power to permissible regenerative power is displayed in %.	○	○	○
Effective load ratio	J	%	The continuous effective load current is displayed. The effective value in the past 15 s is displayed, with the rated current being 100 %.	○	○	○
Peak load ratio	b	%	The maximum torque generated is displayed. The highest value in the past 15 s is displayed, with the rated torque being 100 %.	○	○	○
Instantaneous torque	T	%	The instantaneous torque is displayed. The torque generated is displayed in real time, with the rated torque being 100%.	○	○	○
Position within one-revolution (1 pulse unit)	Cy1	pulse	Position within one revolution is displayed in encoder pulses. When the count exceeds 999, it starts from 0. When the servo motor rotates in the CCW direction, the value is added.	○	○	○
Position within one-revolution (1000 pulses unit)	Cy2	1000 pulses	The within one-revolution position is displayed in 1000 pulse increments of the encoder. When the count exceeds 999, it starts from 0. When the servo motor rotates in the CCW direction, the value is added.	○	○	○
Position within one-revolution (1000000 pulses unit)	Cy3	1000000 pulses	The within one-revolution position is displayed in 1000000 pulse increments of the encoder. When the count exceeds 999, it starts from 0. When the servo motor rotates in the CCW direction, the value is added.	○	○	○

3. DISPLAY AND OPERATION SECTIONS

Status display	Symbol	Unit	Description	Control mode (Note 1)		
				CP	CL	PS
ABS counter (1 rev unit)	LSL	rev	The travel distance from the home position is displayed as multi-revolution counter value of the absolute position encoder in the absolute position detection system. Negative value is indicated by the lit decimal points in the upper two digits.	○	○	△
ABS counter (1000 rev unit)	LSh	1000 rev		○	○	△
ABS counter (1 rev unit)	LSL	rev	The travel distance from the home position is displayed as load side multi-revolution counter value in the absolute position detection system. Negative value is indicated by the lit decimal points in the upper two digits.	△	△	○
ABS counter (1000 rev unit)	LSh	1000 rev		△	△	○
Load to motor inertia ratio (0.1 times)	dCL	0.1 time	The estimated ratio of the load inertia moment to the servo motor shaft inertia moment is displayed.	○	○	○
Load to motor inertia ratio (100 times)	dCh	100 times		○	○	○
Bus voltage	Pn	V	The voltage of main circuit converter is displayed. It is displayed rounding off 0.1 V unit.	○	○	○
Encoder inside temperature	ETh	°C	Inside temperature of encoder detected by the encoder is displayed.	○	○	○
Settling time	ST	ms	Displays settling time. When it exceeds 999 ms, "999" will be displayed.	○	○	○
Oscillation detection frequency (1 Hz unit)	oFL	Hz	Frequency at the time of oscillation detection is displayed.	○	○	○
Oscillation detection frequency (1 kHz unit)	oFh	kHz		○	○	○
The number of tough drive operations (time)	Td1	times	The number of tough drive functions activated is displayed.	○	○	○
The number of tough drive operations (1000 times)	Td2	1000 times		○	○	○
Unit power consumption 1 (1 W unit)	PC1	W	Unit power consumption is displayed by increment of 1 W. Positive value indicate power running, and negative value indicate regeneration. The values in excess of ±999 can be counted. However, the counter shows only the lower three digits of the actual value since the servo amplifier display is three digits. Negative value is indicated by the lit decimal points in the upper two digits.	○	○	○
Unit power consumption 2 (1 kW unit)	PC2	kW	Unit power consumption is displayed by increment of 1 kW. Positive value indicate power running, and negative value indicate regeneration. The values in excess of ±99 can be counted. However, the counter shows only the lower three digits of the actual value since the servo amplifier display is three digits. Negative value is indicated by the lit decimal points in the upper two digits.	○	○	○
Unit total power consumption (1 Wh unit)	TP1	Wh	Unit total power consumption is displayed by increment of 1 Wh. Positive value is cumulated during power running and negative value during regeneration. The values in excess of ±999 can be counted. However, the counter shows only the lower three digits of the actual value since the servo amplifier display is three digits. Negative value is indicated by the lit decimal points in the upper two digits.	○	○	○
Unit total power consumption 2 (1 kWh unit)	TP2	kWh	Unit total power consumption is displayed by increment of 1 kWh. Positive value is cumulated during power running and negative value during regeneration. The values in excess of ±999 can be counted. However, the counter shows only the lower three digits of the actual value since the servo amplifier display is three digits. Negative value is indicated by the lit decimal points in the upper two digits.	○	○	○
Unit total power consumption 3 (1000 kWh unit)	TP3	1000 kWh	Unit total power consumption is displayed by increment of 1000 kWh. Positive value is cumulated during power running and negative value during regeneration. The values in excess of ±99 can be counted. However, the counter shows only the lower three digits of the actual value since the servo amplifier display is three digits. Negative value is indicated by the lit decimal points in the upper two digits.	○	○	○
Current position - Low	PSL	μm 0.0001 inch 0.001 degree pulse (Note 2)	When "_ _ 0 _" (positioning display) is set in [Pr. PT26], the current position is displayed as machine home position is 0. When "_ _ 1 _" (roll feed display) is set in [Pr. PT26], the actual current position is displayed as start position is 0.	○	○	△
Current position - High	PSh	1000 μm 0.1 inch degree 1000 pulses (Note 2)		○	○	△

3. DISPLAY AND OPERATION SECTIONS

Status display	Symbol	Unit	Description	Control mode (Note 1)		
				C P	C L	P S
Command position - Low	CPL	μm 0.0001 inch 0.001 degree pulse (Note 2)	When " __ 0 _" (positioning display) is set in [Pr. PT26], the command current position is displayed as machine home position is 0. When " __ 1 _" (roll feed display) is set in [Pr. PT26], turning on the start signal starts counting from 0 and a command current position to the target position is displayed in the automatic mode.	<input type="radio"/>	<input type="radio"/>	<input type="checkbox"/>
Command position - High	CPh	1000 μm 0.1 inch degree 1000 pulses (Note 2)	The command positions of the selected point table are displayed at a stop. At the manual mode, the command positions of the selected point table are displayed. Negative value is indicated by the lit decimal points in the upper two digits.	<input type="radio"/>	<input type="radio"/>	<input type="checkbox"/>
Command remaining distance - Low	rnL	μm 0.0001 inch 0.001 degree pulse (Note 2)	The remaining distance to the command position of the currently selected point table/program is displayed. Negative value is indicated by the lit decimal points in the upper two digits.	<input type="radio"/>	<input type="radio"/>	<input type="checkbox"/>
Command remaining distance - High	rnH	1000 μm 0.1 inch degree 1000 pulses (Note 2)		<input type="radio"/>	<input type="radio"/>	<input type="checkbox"/>
Point table No./program No./command station position	Pno		For the point table method and program method, the point table and program No. currently being executed are displayed. The selected number is displayed during a temporary stop or manual operation. For the indexer method, the command next station position is displayed.	<input type="radio"/>	<input type="radio"/>	<input type="radio"/>
Step No.	Sno		The step No. of the program currently being executed is displayed. At a stop, 0 is displayed.	<input type="checkbox"/>	<input type="radio"/>	<input type="checkbox"/>
Analog override voltage	oru	V	The analog override voltage is displayed.	<input type="radio"/>	<input type="radio"/>	<input type="checkbox"/>
Override level	or	%	The setting value of the override is displayed. When the override is disabled, 100% is displayed.	<input type="radio"/>	<input type="radio"/>	<input type="radio"/>

Note 1. CP: Positioning mode (point table method)

CL: Positioning mode (program method)

PS: Positioning mode (indexer method)

2. The unit can be selected from μm /inch/degree/pulse with [Pr. PT01].

(3) Changing the status display screen

The status display on the servo amplifier at power-on can be changed with [Pr. PC36]. The status displayed by default varies depending on the control mode as follows:

Control mode	Status display
Position	Cumulative feedback pulses (pulse unit)
Position/speed	Cumulative feedback pulses (pulse unit)/ Servo motor speed (r/min unit)
Speed	Servo motor speed (r/min unit)
Speed/torque	Servo motor speed (r/min unit)/Instantaneous torque
Torque	Instantaneous torque
Torque/position	Instantaneous torque/Cumulative feedback pulses (pulse unit)
Positioning (point table method/program method)	Current position - Low
Positioning (indexer method)	Cumulative feedback pulses (pulse unit)

3. DISPLAY AND OPERATION SECTIONS

3.2.3 Diagnostic mode





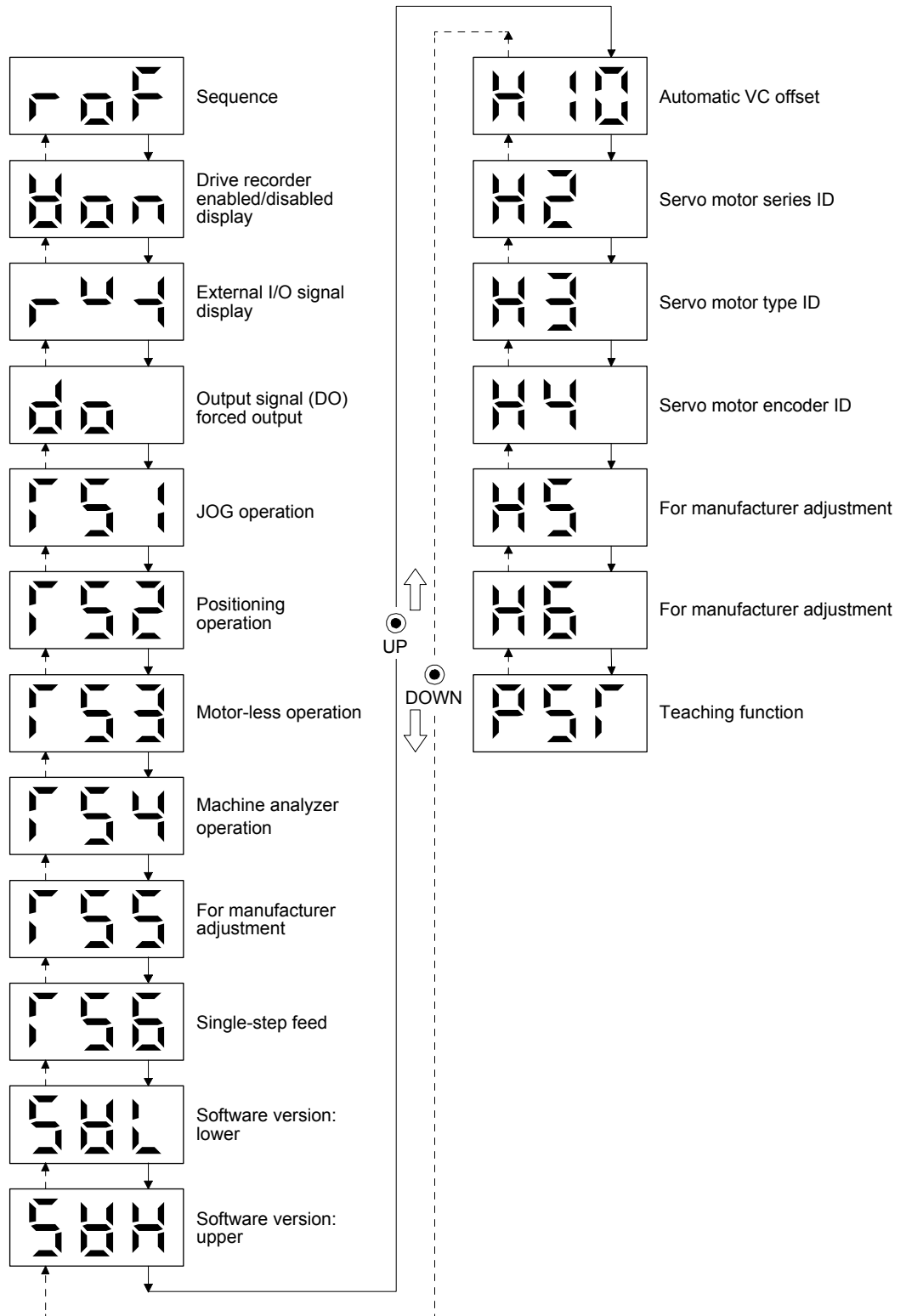





Diagnosis contents can be displayed on the display. Press the "UP" or "DOWN" button to change the display data as desired.

(1) Display transition

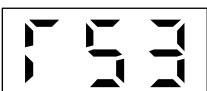

3. DISPLAY AND OPERATION SECTIONS

(2) Diagnosis display list

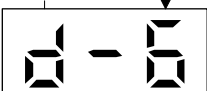

Name		Display	Description
Sequence			Not ready Indicates that the servo amplifier is being initialized or an alarm has occurred.
			Ready Indicates that initialization is completed, and the servo amplifier is in servo-on state and ready to operate.
Drive recorder enabled/disabled display			Drive recorder enabled When an alarm occurs in this state, the drive recorder will operate and record the status of occurrence.
			Drive recorder disabled The drive recorder will not operate on the following conditions. 1.The graph function of MR Configurator2 is being used. 2.The machine analyzer function is being used. 3.[Pr. PF21] is set to "-1".
External I/O signal display		Refer to section 3.2.7.	This Indicates the on/off status of external I/O signal.
Output signal (DO) forced output			This allows digital output signal to be switched on/off forcibly. Refer to section 3.2.8 for details.
Test operation mode	JOG operation		JOG operation can be performed when there is no command from an external controller. For details, refer to section 18.5.10 (2) of "MR-J4-_A_(-RJ) Servo Amplifier Instruction Manual".
	Positioning operation		Positioning operation can be performed when there is no command from an external controller. MR Configurator2 is required to perform positioning operation. For details, refer to section 4.5.9 (3) of "MR-J4-_A_(-RJ) Servo Amplifier Instruction Manual".
	Motor-less operation		Without connecting the servo motor, output signals or status display can be provided in response to the input device as if the servo motor is actually running. For details, refer to section 4.5.9 (4) of "MR-J4-_A_(-RJ) Servo Amplifier Instruction Manual".
	Machine analyzer operation		Merely connecting the servo amplifier allows the resonance point of the mechanical system to be measured. MR Configurator2 is required to perform machine analyzer operation. For details, refer to section 11.7 of "MR-J4-_A_(-RJ) Servo Amplifier Instruction Manual".
	For manufacturer adjustment		This is for manufacturer adjustment.
	Single-step feed	 	This function is available only in the point table method and program method. When the positioning operation is executed in accordance with the point table or program set by MR Configurator2, the diagnosis display changes to "d-6" during single-step feed. For other control mode, the display does not change to "d-6". Refer to section 3.2.9 for details. The status will be displayed with the "MODE" button. The "UP" and "DOWN" buttons are disabled.

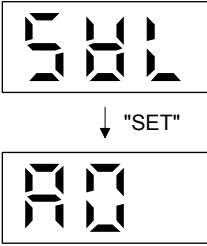
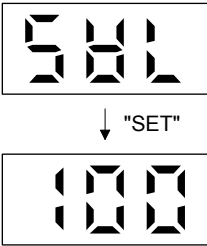
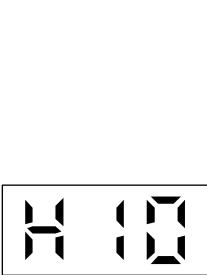
3. DISPLAY AND OPERATION SECTIONS

Name	Display	Description
Software version: lower		<p>Indicates the version of the software.</p> <p>The software version is displayed while the "SET" button is pressed and held.</p> <p>Press the "MODE" button to shift to the next display mode.</p> <p>Press the "UP" or "DOWN" button to shift to the next diagnosis menu.</p>
Software version: upper		<p>Indicates the system number of the software.</p> <p>The software system number is displayed while the "SET" button is pressed and held.</p> <p>Press the "MODE" button to shift to the next display mode.</p> <p>Press the "UP" or "DOWN" button to shift to the next diagnosis menu.</p>
Automatic VC offset		<p>If offset voltages in the analog circuits inside and outside the servo amplifier cause the servo motor setting speed not to be the designated value at VC (Analog override) of 0 V, a zero-adjustment of offset voltages will be automatically performed.</p> <p>When using this function, enable the function in the following procedure. When it is enabled, [Pr. PC37] value changes to the automatically adjusted offset voltage.</p> <ol style="list-style-type: none"> 1) Press the "SET" button once. 2) Set the number in the first digit to "1" with the "UP" button. 3) Press the "SET" button. <p>This function cannot be used if the input voltage of VC is -0.4 V or less, or +0.4 V or more. (Note)</p>

Note. Even if VC automatic offset is performed and 0 V is inputted, the speed may not completely be the set value.

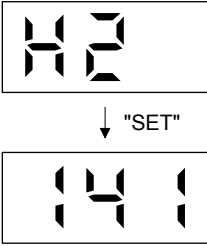
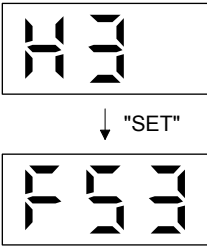
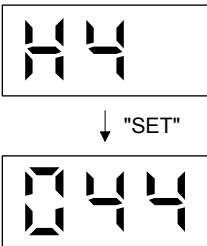
3. DISPLAY AND OPERATION SECTIONS

Name	Display	Description
Servo motor series ID	 <p style="text-align: center;">↓ "SET"</p>	<p>Displays the series ID of the servo motor currently connected.</p> <p>Press the "SET" button to show the lower 3 digits of servo motor series ID.</p> <p>For indication details, refer to app. 1 of "Servo Motor Instruction Manual (Vol. 3)".</p> <p>Press the "UP" or "DOWN" button to shift to the next diagnosis menu.</p>
Servo motor type ID	 <p style="text-align: center;">↓ "SET"</p>	<p>Displays the type ID of the servo motor currently connected.</p> <p>Press the "SET" button to show the lower 3 digits of servo motor type ID.</p> <p>For indication details, refer to app. 1 of "Servo Motor Instruction Manual (Vol. 3)".</p> <p>Press the "UP" or "DOWN" button to shift to the next diagnosis menu.</p>
Servo motor encoder ID	 <p style="text-align: center;">↓ "SET"</p>	<p>Displays the servo motor encoder ID of the servo motor currently connected.</p> <p>Press the "SET" button to show the lower 3 digits of servo motor encoder ID.</p> <p>For indication details, refer to app. 1 of "Servo Motor Instruction Manual (Vol. 3)".</p> <p>Press the "UP" or "DOWN" button to shift to the next diagnosis menu.</p>
For manufacturer adjustment		<p>This is for manufacturer adjustment.</p>
For manufacturer adjustment		<p>This is for manufacturer adjustment.</p>
Teaching function	<p style="text-align: center;">Refer to section 3.2.10.</p>	<p>After an operation travels to a target position (MEND (Travel completion) is turned on) with a JOG operation or manual pulse generator operation, pushing the "SET" button of the operation area or turning on TCH (Teach) will import the position data. This function is available only in the point table method. In other control modes, the display remains the same.</p>

3. DISPLAY AND OPERATION SECTIONS

3.2.4 Alarm mode

The current alarm, past alarm history, and parameter error are displayed. The alarm number that has occurred or the parameter numbers in error are displayed on the display.

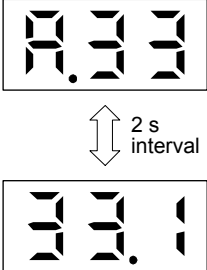
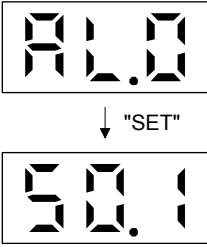
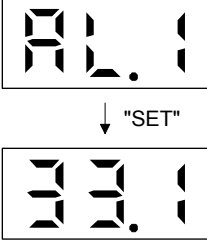
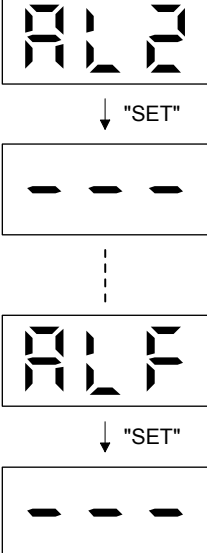
Name	Display (Note 1)	Description
Current alarm		Indicates no occurrence of an alarm.
	 <p style="text-align: center;">↕ 2 s interval</p>	Indicates the occurrence of [AL. 33.1 Main circuit voltage error]. Flickers at alarm occurrence. The alarm number and detail number are displayed alternately by intervals of 2 s.
Alarm history	 <p style="text-align: center;">↓ "SET"</p>	Indicates that the last alarm is [AL. 50.1 Thermal overload error 1 during operation]. When an alarm is recorded to alarm history, the second digit decimal point flickers. Press the "SET" button to display the detail number of [AL. 50].
	 <p style="text-align: center;">↓ "SET"</p>	Indicates the second last alarm is [AL. 33.1 Main circuit voltage error]. When an alarm is recorded to alarm history, the second digit decimal point flickers. Press the "SET" button to display the detail number of [AL. 33].
	 <p style="text-align: center;">↓ "SET"</p>	Indicates that there is no third alarm in the past. If there is no alarm history, the display will be as shown as in the left, when the "SET" button is pressed.
		Indicates that there is no sixteenth alarm in the past.

3. DISPLAY AND OPERATION SECTIONS

Name	Display (Note 1)	Description
Parameter error No./point table error No. (Note 2)		This indicates no occurrence of [AL. 37 Parameter error].
	 ↓ "SET" 	The data content error of [Pr. PA12 Reverse rotation torque limit]. The parameter group in which the parameter error has occurred is displayed. Press and hold the "SET" button to show the parameter number with the error.
	 ↓ "SET" 	This indicates that the position data of the point table No. 23 has exceeded the setting range. An error item of the point table is displayed. The point table No. having the error is displayed while the "SET" button is being pressed and held. The following shows the items of a point table: P: position data, d: motor speed, A: acceleration time constant, b: deceleration time constant, n: dwell, H: auxiliary function, M: M code

- Note 1. If a parameter error and point table error occur simultaneously, the display shows the parameter error.
2. The display shows only when the current alarm is [AL. 37 Parameter error].

Functions at occurrence of an alarm

- (1) The current alarm is displayed in any mode.
- (2) Even during an alarm occurrence, the other display can be viewed by pressing the button in the operation area. At this time, the decimal point in the third digit remains flickering.
- (3) Remove the cause of the alarm and clear it with any of the following methods. (Refer to chapter 8 for the alarms that can be cleared.)
 - (a) Cycle the power.
 - (b) Press the "SET" button on the current alarm display.
 - (c) Turn on RES (Reset).
- (4) Use [Pr. PC18] to clear the alarm history.
- (5) Press the "UP" or "DOWN" button to move to the next history.

3. DISPLAY AND OPERATION SECTIONS

3.2.5 Point table setting

POINT

● Point table No. 1 to No. 99 can be set with the operation section of the servo amplifier. To set point table No. 100 to No. 255, use MR Configurator2.

You can set the target position, servo motor speed, acceleration time constant, deceleration time constant, dwell, auxiliary function and M code.

(1) Display transition

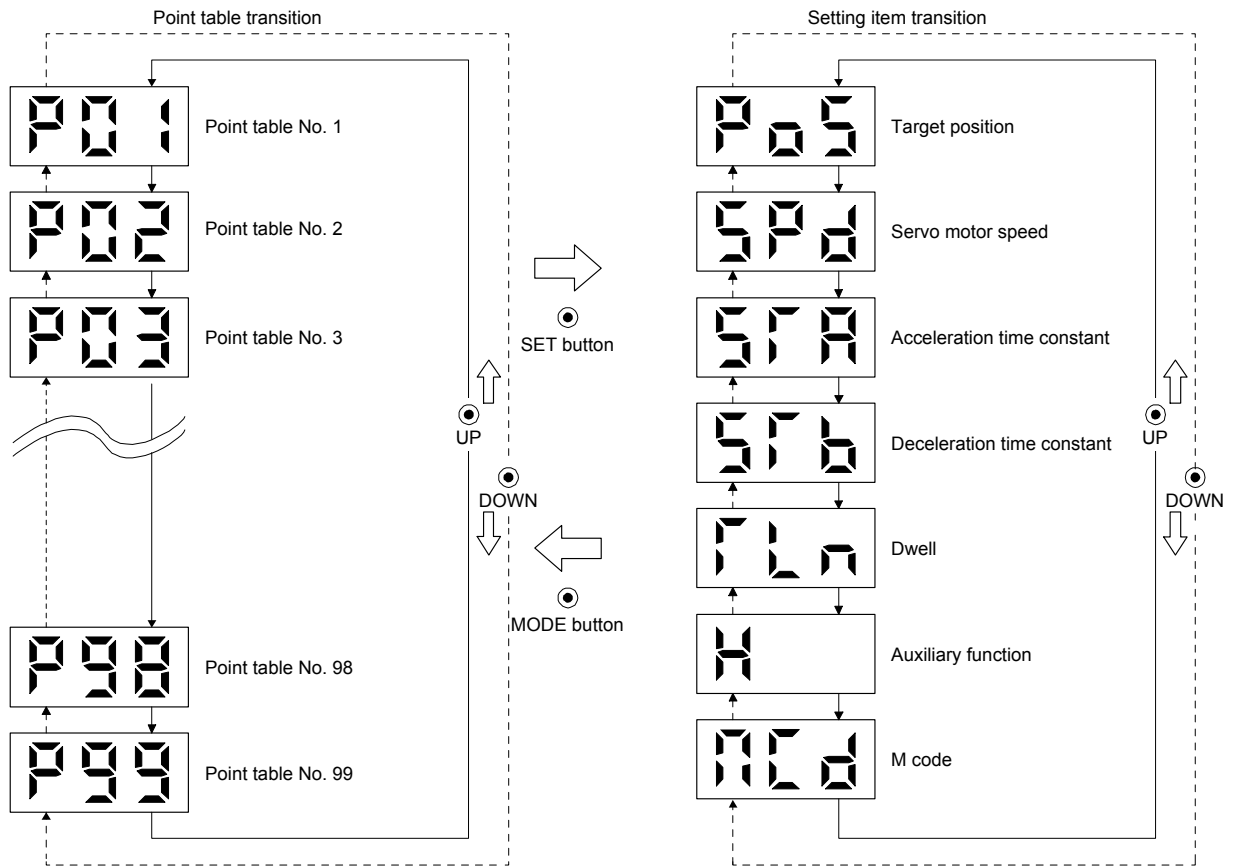

3. DISPLAY AND OPERATION SECTIONS

(2) Setting list

The following point table setting can be displayed.

Status display	Symbol	Unit	Description	Indication range
Point table No.	P01		Specify the point table to set the target position, servo motor speed, acceleration time constant, deceleration time constant, dwell, auxiliary function, and M code.	1 to 255
Target position	PoS	10 ^{STM} μm 10 ^(STM-4) inch 10 ⁻³ degree pulse (Note)	Set the travel distance.	-999999 to 999999
Servo motor speed	SPd	r/min	Set the command speed of the servo motor for execution of positioning. The setting value must be within the permissible speed of the servo motor used. If a value equal to or larger than the permissible speed is set, the value will be clamped at the permissible speed.	0 to Permissible speed
Acceleration time constant	STA	ms	Set a time for the servo motor to reach the rated speed.	0 to 20000
Deceleration time constant	STb	ms	Set a time for the servo motor to stop from the rated speed.	0 to 20000
Dwell	TLn	ms	This function is enabled when you select the point table by input signal. To disable the dwell, set "0" or "2" to the auxiliary function. To perform a varying-speed operation, set "1", "3", "8", "9", "10", or "11" to the auxiliary function and 0 to the dwell. When the dwell is set, the position command of the selected point table is completed. After the set dwell has elapsed, start the position command of the next point table.	0 to 20000
Auxiliary function	H		This function is enabled when you select the point table by input signal. (1) When using the point table with the absolute value command method 0: Executes automatic operation for a selected point table. 1: Executes automatic continuous operation without stopping for the next point table. 8: Executes automatic continuous operation without stopping for the point table selected at the start. 9: Automatic continuous operation is performed to point table No. 1. (2) When using this point table with the incremental value command method 2: Executes automatic operation for a selected point table. 3: Executes automatic continuous operation without stopping for the next point table. 10: Executes automatic continuous operation without stopping for the point table selected at the start. 11: Automatic continuous operation is performed to point table No. 1. When an opposite rotation direction is set, the servo motor rotates in the opposite direction after smoothing zero (command output) is confirmed. When "1" or "3" is set to the point table No. 255, [AL. 61] will occur at the time of point table execution.	0 to 3, 8 to 11
M code	MCd		This is the code output at the completion of positioning. The first digit and the second digit of the M code are outputted in 4-bit binary respectively.	0 to 99

Note. The unit can be selected from μm/inch/degree/pulse with [Pr. PT01].

3. DISPLAY AND OPERATION SECTIONS

(3) Operation method

POINT

● After changing and defining the setting values of the specified point table, the defined setting values of the point table are displayed. To discard the changed setting, press the "MODE" button for 2 s or more. The setting before the change will be displayed. Keep pressing the "UP" or "DOWN" button to continuously change the most significant digit of the setting values.

(a) Setting of 3 or less digits

The following example is the operation method at power-on to set "1" to the auxiliary function of the point table No. 1.

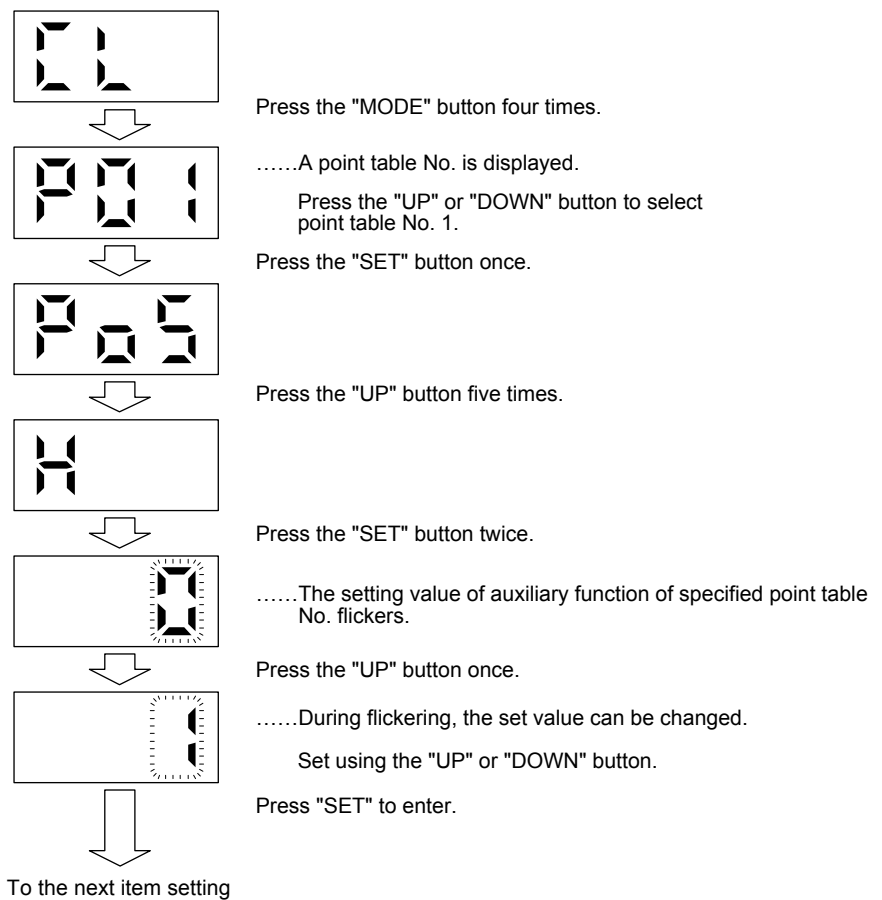

Press the "UP" or "DOWN" button to switch to other item of the same point table No.
Press the "MODE" button to switch to the next point table No.

3. DISPLAY AND OPERATION SECTIONS

(b) Setting of 4 to 6 digits

The following example is the operation method to change the position data of the point table No. 1 to "123456".

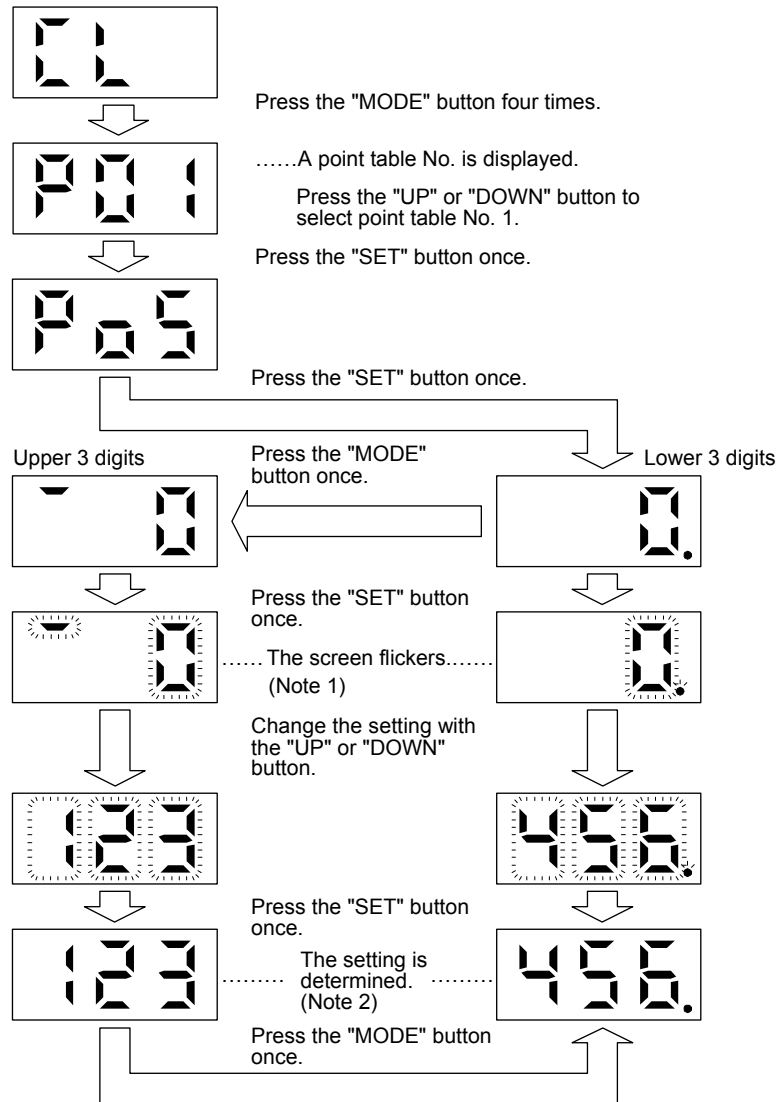

- Note 1. Pressing the "SET" button in either upper or lower 3-digit display makes the display flicker.
2. Press the "SET" button to confirm on upper 3-digits or lower 3-digits screen.

The display can be switched between upper and lower 3-digit by pressing the "MODE" button. Switching the display between upper and lower 3-digit is also possible by pressing the "MODE" button while the display is flickering.

The changed value will be canceled when the "MODE" button is pressed for 2 s or more while flickering.

Press the "UP" or "DOWN" button to switch to other item of the same point table No.

Press the "MODE" button to switch to the next point table No.

3. DISPLAY AND OPERATION SECTIONS

3.2.6 Parameter mode

(1) Parameter mode transition

After selecting the corresponding parameter mode with the "MODE" button, pressing the "UP" or "DOWN" button changes the display as follows.

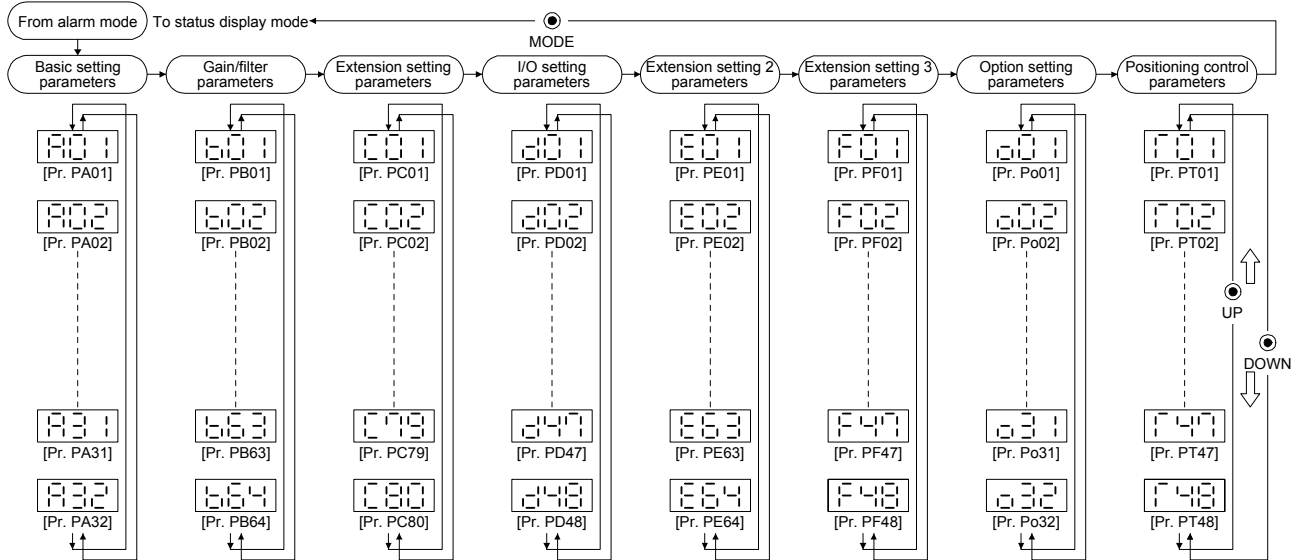

3. DISPLAY AND OPERATION SECTIONS

(2) Operation method

(a) Parameters of 3 or less decimal digits.

The following example gives the operation procedure to change [Pr. PA Reverse rotation torque limit].

Press the "MODE" button to switch to the basic setting parameters screen.

Parameter number selection



Select a parameter number with the "UP" or "DOWN" button.

Press the "SET" button to display the item to be set to the selected parameter number.

Displaying the parameter contents



Press the "UP" or "DOWN" button to shift to the setting display of the next parameter number.

Press the "MODE" button to shift to the next display.

Press the "SET" button once to display the setting.

Press the "SET" button once when the setting is displayed. The setting flickers and is possible to be changed.

Changing the parameter contents

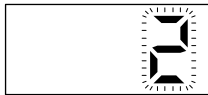

Press the "UP" or "DOWN" button to change the value and press the "SET" button to fix the setting. The setting will be displayed as it is after the setting is fixed.

To cancel the setting data, press the "MODE" button for 2 s while the display is flickering. The setting before the change will be displayed.

Press and hold the "UP" or "DOWN" button to change the data continuously.

In that case, only the highest digit changes.

Example of pressing and holding the "UP" button

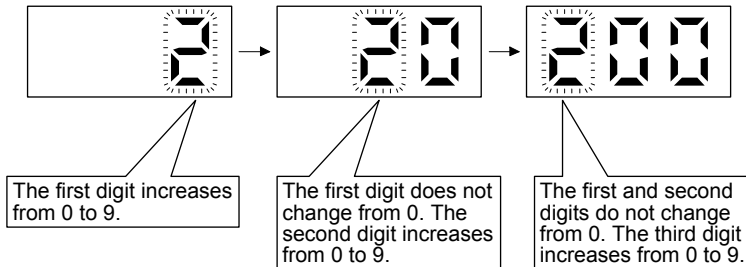

Example of pressing and holding the "DOWN" button

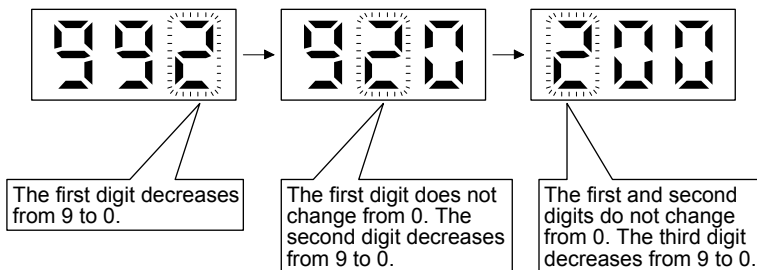

3. DISPLAY AND OPERATION SECTIONS

(b) Parameters of 4 to 6 decimal digits

The following example gives the operation procedure to change [Pr. PB03 Positioning command acceleration/deceleration time constants (position smoothing)] to "65535".

Press the "MODE" button to switch to the gain/filter setting parameters screen.

Press the "UP" or "DOWN" button to select [Pr. PB03].

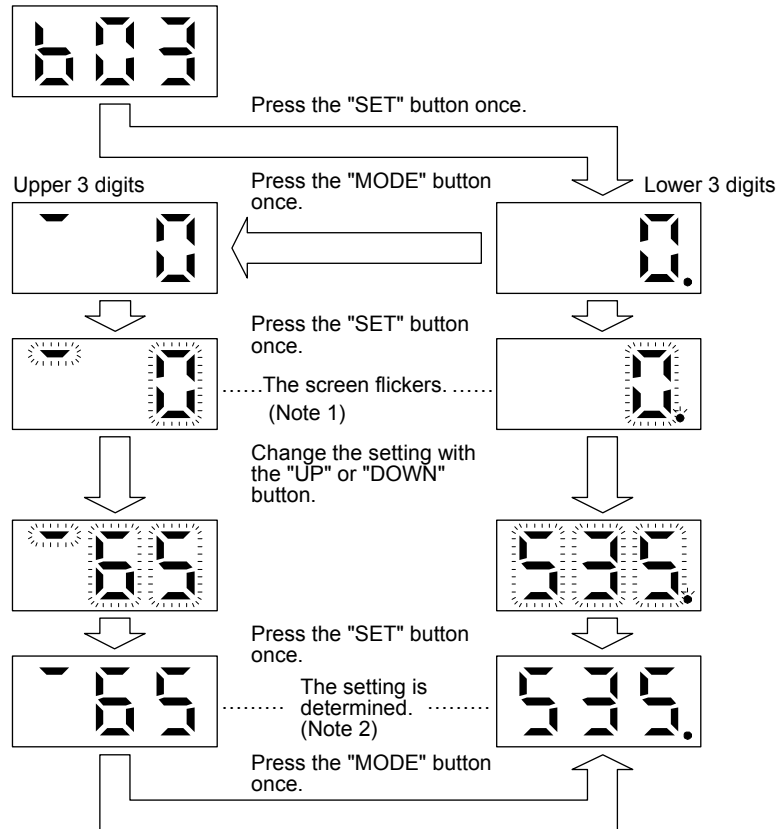

- Note 1. Pressing the "SET" button in either upper or lower 3-digit display makes the display flicker.
- Note 2. Press the "SET" button to confirm on upper 3-digits or lower 3-digits screen.

The display can be switched between upper and lower 3-digit by pressing the "MODE" button. Switching the display between upper and lower 3-digit is also possible by pressing the "MODE" button while the display is flickering.

The changed value will be canceled when the "MODE" button is pressed for 2 s or more while flickering.

To shift to the next parameter number, press the "UP" or "DOWN" button.

To change the screen to another, press the "UP" or "DOWN" button to change the screen to another parameter number display screen and press the "MODE" button.

3. DISPLAY AND OPERATION SECTIONS

(c) Parameters of 7 or more decimal digits

The following example gives the operation procedure to change the [Pr. PA06 Electronic gear numerator (command pulse multiplication numerator)] to "12345678".

Press the "MODE" button to switch to the basic setting parameters screen.

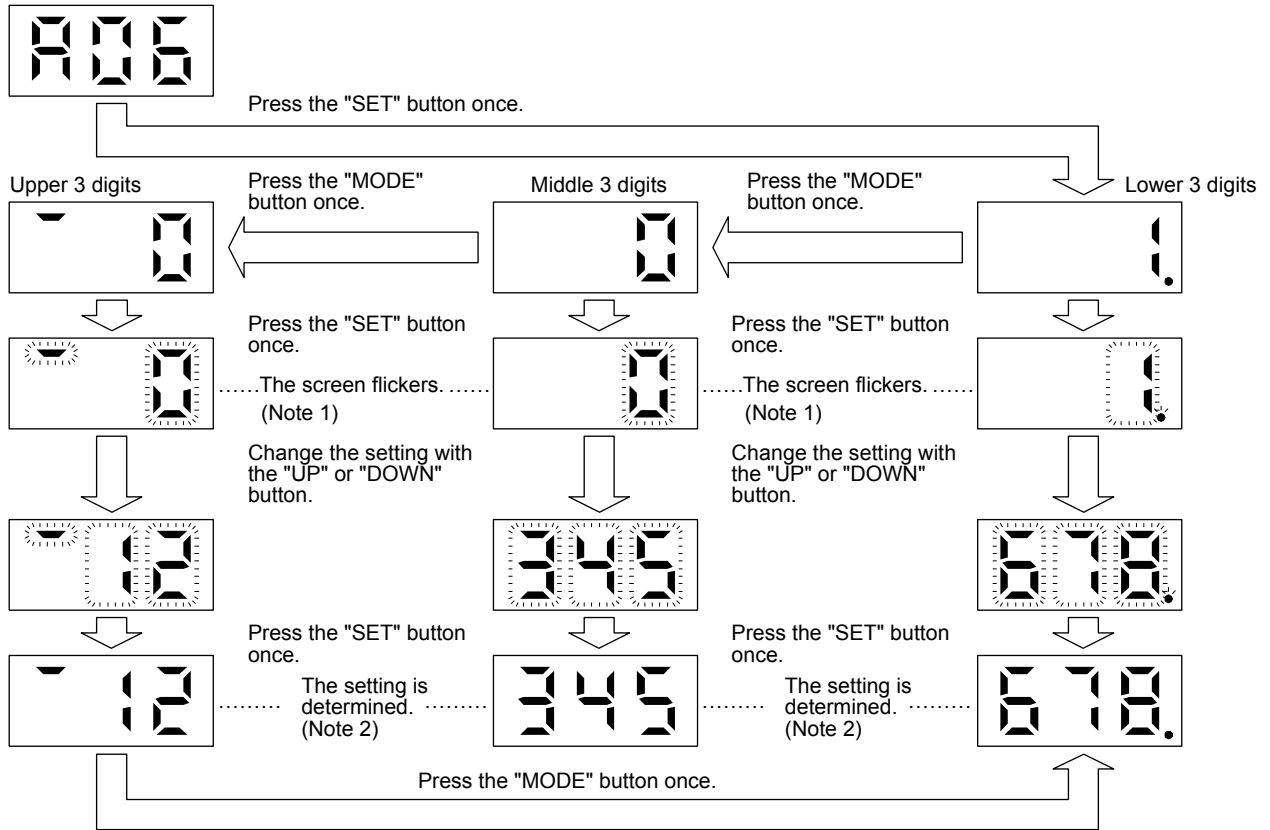

- Note 1. Pressing the "SET" button in upper, middle, or lower 3-digit display makes the display flicker.
 Note 2. Pressing the "SET" button in upper, middle, or lower 3-digit display fixes the setting.

The display can be switched among upper, middle, and lower 3-digits by pressing the "MODE" button.

Switching the display between upper, middle, and lower 3-digit is also possible by pressing the "MODE" button while the display is flickering.

The changed value will be canceled when the "MODE" button is pressed for 2 s or more while flickering.

To shift to the next parameter number, press the "UP" or "DOWN" button.

To change the screen to another, press the "UP" or "DOWN" button to change the screen to another parameter number display screen and press the "MODE" button.

3. DISPLAY AND OPERATION SECTIONS

(d) Parameter of hexadecimal

The following example gives the operation procedure to change the [Pr. PA01 Operation mode] to "1234".

Press the "MODE" button to switch to the basic setting parameters screen.

Press the "UP" or "DOWN" button to select [Pr. PA01].

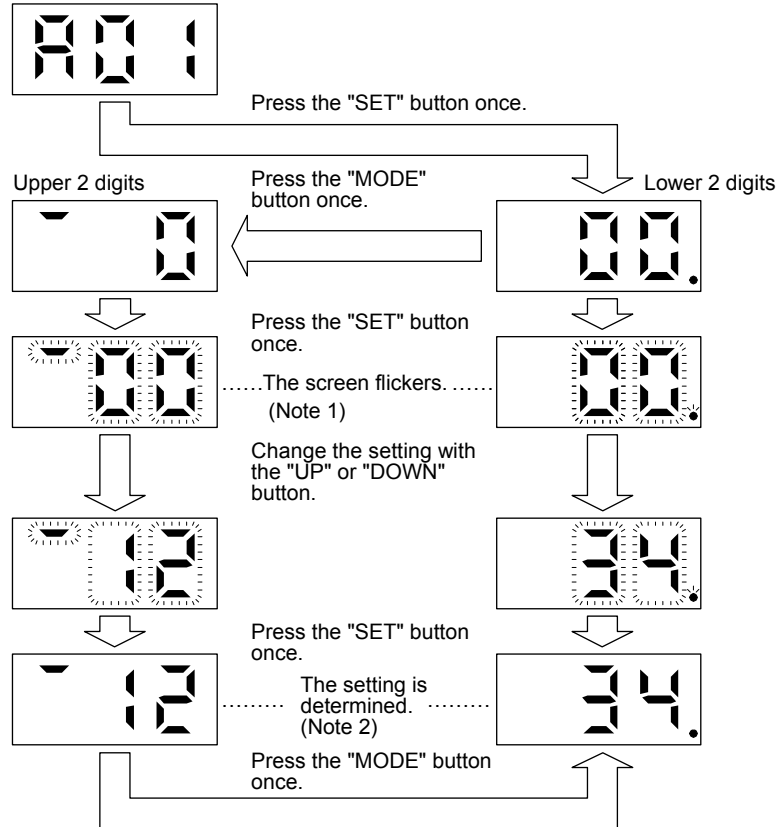

- Note 1. Pressing the "SET" button in upper, middle, or lower 2-digit display makes the display flicker.
- Note 2. Press the "SET" button to confirm on upper 2-digits or lower 2-digits screen.

The display can be switched among upper, middle, and lower 2-digits by pressing the "MODE" button.

Switch the display between upper, middle, and lower 2-digit is also possible by pressing the "MODE" button while the display is flickering.

The changed value will be canceled when the "MODE" button is pressed for 2 s or more while flickering.

To shift to the next parameter number, press the "UP" or "DOWN" button.

To change the screen to another, press the "UP" or "DOWN" button to change the screen to another parameter number display screen and press the "MODE" button.

3. DISPLAY AND OPERATION SECTIONS

3.2.7 External I/O signal display

POINT
<p>●The I/O signal settings can be changed using I/O setting parameters [Pr. PD04] to [Pr. PD28].</p>

The on/off states of the digital I/O signals connected to the servo amplifier can be confirmed.

(1) Operation

The display at power-on. Use the "MODE" button to display the diagnostic screen.

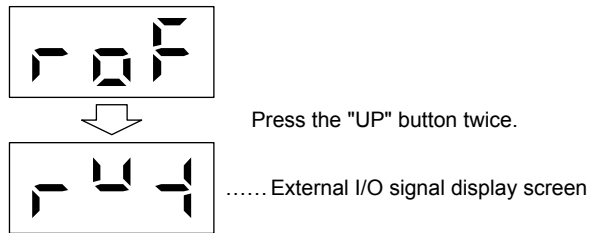

(2) Display definition

The 7-segment LED segments and CN1 connector pins correspond as shown below.

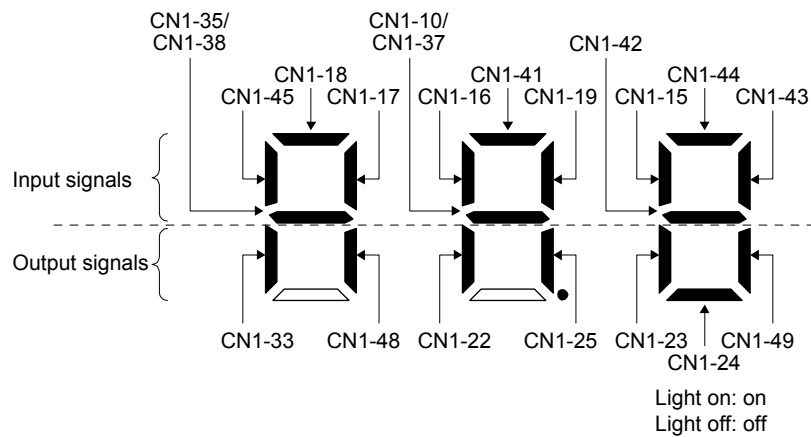

The LED segment corresponding to the pin is lit to indicate on, and is extinguished to indicate off. The decimal point in the second digit flickers continuously.

For each pin signal in control modes, refer to section 2.2 (2).

3. DISPLAY AND OPERATION SECTIONS

3.2.8 Output signal (DO) forced output

POINT

● When the servo system is used in a vertical lift application, turning on MBR (Electromagnetic brake interlock) by the DO forced output after assigning it to connector CN1 will release the electromagnetic brake, causing a drop. Take drop preventive measures on the machine side.

Output signals can be switched on/off forcibly independently of the servo status. Use this function for checking output signal wiring, etc. This operation must be performed in the servo off state by turning off SON (Servo-on).

The display at power-on. Use the "MODE" button to display the diagnostic screen.

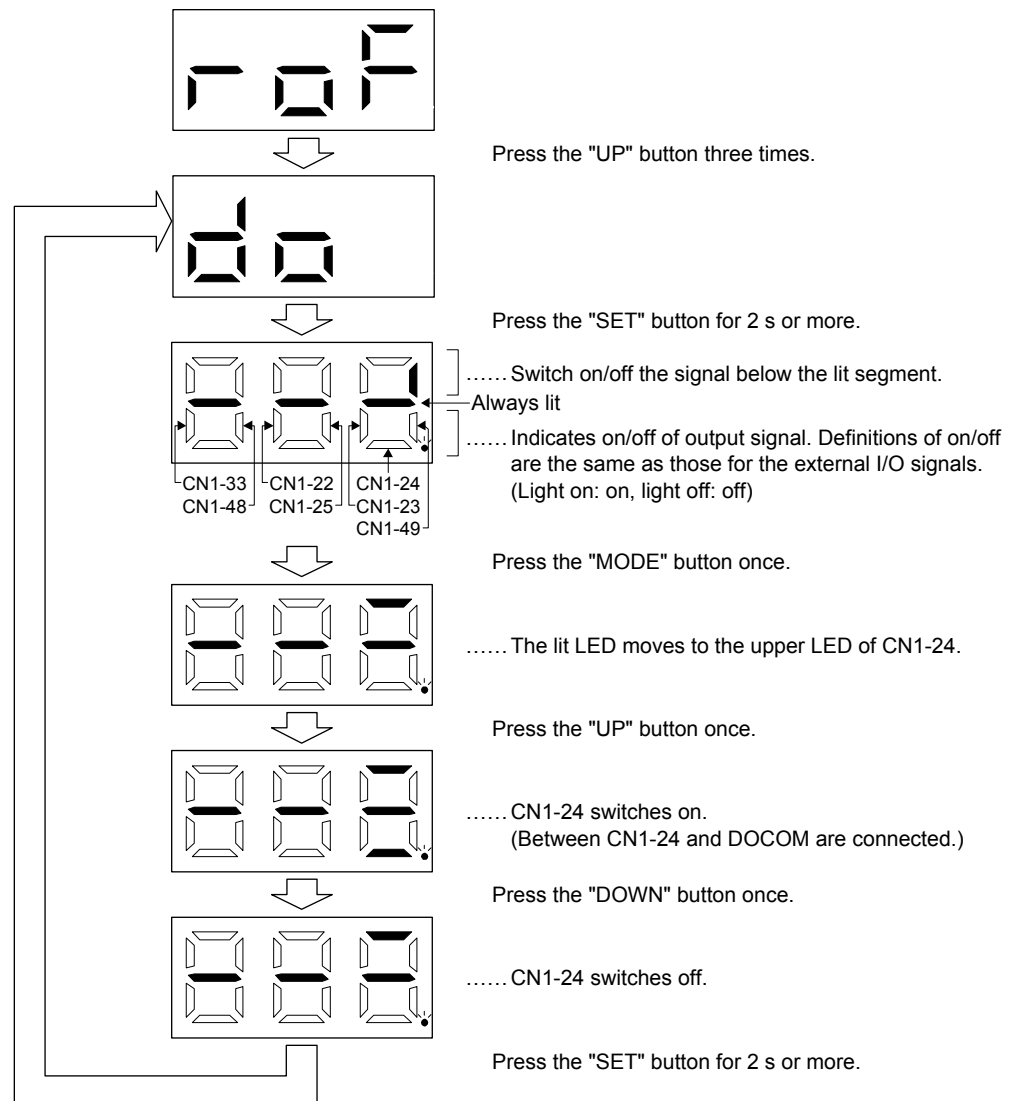

3. DISPLAY AND OPERATION SECTIONS

3.2.9 Step feed



CAUTION

- The test operation mode is designed for checking servo operation. Do not use it for an actual operation.
- If the servo motor operates unexpectedly, use EM2 (Forced stop 2) to stop it.

POINT

- MR Configurator2 is required to perform single-step feed.
- Test operation cannot be performed unless SON (Servo-on) is not turned off.

The positioning operation can be performed in accordance with the point table No. or the program No. set by MR Configurator2.

Select the test operation/single-step feed from the menu of MR Configurator2. When the single-step feed window is displayed, input the following items and operate.

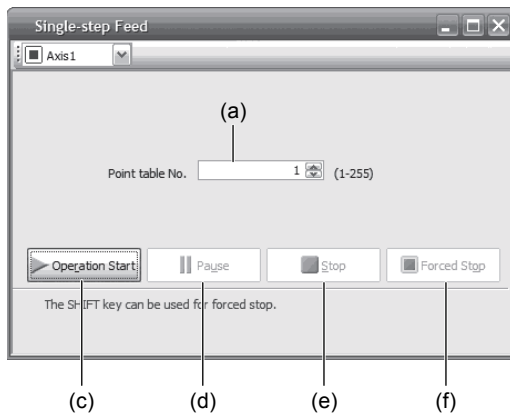

Point table operation

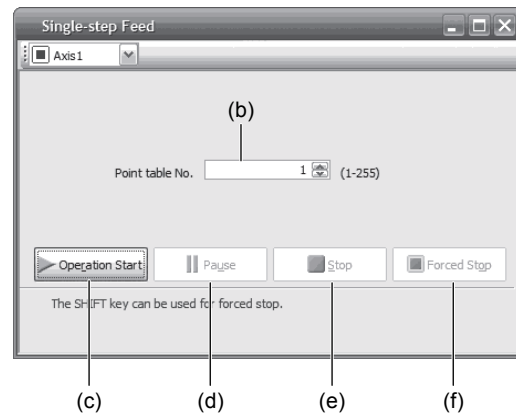

Program operation

- (1) Point table No. or program No. setting
Enter a point table No. in the input box (a) "Point table No.", or a program No. in the input box (b) "Program No."
- (2) Starting the servo motor
Click "Operation Start" (c) to rotate the servo motor.
- (3) Temporarily stopping the servo motor
Click "Pause" (d) to temporarily stop the servo motor.
While the servo motor is temporarily stopped, click "Operation Start" (c) to restart the rotation of the remaining travel distance.
While the servo motor is temporarily stopped, click "Stop" (e) to clear the remaining travel distance.
- (4) Stopping the servo motor
Click "Stop" (e) to stop the servo motor. At this time, the remaining travel distance will be cleared. Click "Operation Start" (c) to restart the rotation.

3. DISPLAY AND OPERATION SECTIONS

(5) Forcibly stopping the servo motor software

Click "Forced Stop" (f) to make an instantaneous stop. When "Forced Stop" is enabled, "Operation Start" cannot be used. Click "Forced Stop" again to enable "Operation Start".

(6) Switching to the normal operation mode

Before switching from the test operation mode to the normal operation mode, turn off the servo amplifier.

3. DISPLAY AND OPERATION SECTIONS

3.2.10 Teaching function

After an operation travels to a target position (MEND (Travel completion) is turned on) with a JOG operation or manual pulse generator operation, pushing the "SET" button of the operation area or turning on TCH (Teach) will import the position data. This function is available only in the point table method. In other control modes, the display remains the same.

(1) Teaching preparation



Teaching setting initial display

Press the "SET" button for approximately 2 s to switch to the teaching setting mode.

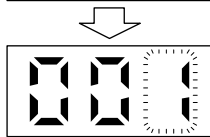

Select the point table No. with the "UP" or "DOWN" button when the first digit on the display flickers.

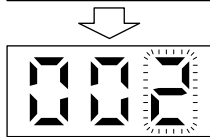

When the first digit on the display flickers, press the "SET" button to complete the teaching setting preparation. When the preparation is properly completed, the first digit on the display is lit and the third digit flickers.

(2) Position data setting method

After an operation travels to a target position (MEND (Travel completion) is turned on) with a JOG operation or manual pulse generator operation, pushing the "SET" button of the operation part or turning on TCH (Teach) will set the positioning address as position data.



When the third digit on the display flickers, the current position is written to the selected point table by pressing the "SET" button.

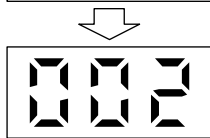

When the first or third digit on the display flickers, the display returns to the teaching setting initial screen by pressing the "MODE" button.

The following shows the conditions for when the teaching function operates.

- (a) When the "positioning command method" of [Pr. PT01] is set to absolute value command method (_ _ 0)
- (b) Home position return completion (ZP (Home position return completion) is turned on)
- (c) While the servo motor is being stopped (command output = 0, MEND (Travel completion) is turned on)

4. HOW TO USE THE POINT TABLE

4. HOW TO USE THE POINT TABLE

The following items are the same as MR-J4- _A_-RJ servo amplifiers. For details, refer to each section indicated in the detailed explanation field. "MR-J4- _A_" means "MR-J4- _A_(-RJ) Servo Amplifier Instruction Manual".

Item	Detailed explanation	
	MR-J4- _A_-RJ 100 W or more	MR-J4-03A6-RJ
Switching power on for the first time	MR-J4- _A_ section 4.1	MR-J4- _A_ section 18.4

POINT
<ul style="list-style-type: none"> ● When you use a linear servo motor, replace the following left words to the right words. <ul style="list-style-type: none"> Load to motor inertia ratio → Load to motor mass ratio Torque → Thrust (Servo motor) speed → (Linear servo motor) speed ● For the mark detection function (Current position latch), refer to section 12.2.1. ● For the mark detection function (Interrupt positioning), refer to section 12.2.2. ● For the infinite feed function (setting degree), refer to section 12.3. ● There are the following restrictions on the number of gear teeth on machine side ([Pr. PA06 Number of gear teeth on machine side]) and the servo motor speed (N). <ul style="list-style-type: none"> ▪ When $CMX \leq 2000$, $N < 3076.7$ r/min ▪ When $CMX > 2000$, $N < (3276.7 - CMX)/10$ r/min When the servo motor is operated at a servo motor speed higher than the limit value, [AL. E3 Absolute position counter warning] will occur.

4. HOW TO USE THE POINT TABLE

4.1 Startup

4.1.1 Power on and off procedures

When the servo amplifier is powered on for the first time, the control mode is set to position control mode. (Refer to section 4.2.1 of "MR-J4-_A_(-RJ) Servo Amplifier Instruction Manual".)

This section provides a case where the servo amplifier is powered on after setting the positioning mode.

(1) Power-on

Switch power on in the following procedure. Always follow this procedure at power-on.

- 1) Switch off SON (Servo-on).
- 2) Make sure that ST1 (Forward rotation start) and ST2 (Reverse rotation start) are off.
- 3) Switch on the main circuit power supply and control circuit power supply.
The display shows "PoS" ("PSL" for MR-J4-03A6-RJ servo amplifiers), and in 2 s later, shows data.



MR-J4-_A_-RJ 100 W or more



MR-J4-03A6-RJ

(2) Power-off

- 1) Switch off ST1 (Forward rotation start) and ST2 (Reverse rotation start).
- 2) Switch off SON (Servo-on).
- 3) Switch off the main circuit power supply and control circuit power supply.

4.1.2 Stop

If any of the following situations occurs, the servo amplifier suspends the running of the servo motor and brings it to a stop.

Refer to section 3.10 of "MR-J4-_A_(-RJ) Servo Amplifier Instruction Manual" for the servo motor with an electromagnetic brake.

Operation/command	Stopping condition
SON (Servo-on) off	The base circuit is shut off and the servo motor coasts.
Alarm occurrence	The servo motor decelerates to a stop with the command. With some alarms, however, the dynamic brake operates to bring the servo motor to a stop. (Refer to chapter 8. (Note 1))
EM2 (Forced stop 2) off	The servo motor decelerates to a stop with the command. [AL. E6 Servo forced stop warning] occurs. Refer to section 2.3 for EM1.
STO (STO1, STO2) off (Note 2)	The base circuit is shut off and the dynamic brake operates to bring the servo motor to a stop.
LSP (Forward rotation stroke end) off, LSN (Reverse rotation stroke end) off	It will bring the motor to a sudden stop and make it servo-locked. It can be run in the opposite direction.

Note 1. Only a list of alarms and warnings is listed in chapter 8. Refer to "MELSERVO-J4 Servo Amplifier Instruction Manual (Troubleshooting)" for details of alarms and warnings.

Note 2. MR-J4-03A6-RJ servo amplifiers are not compatible with the STO function.

4. HOW TO USE THE POINT TABLE

4.1.3 Test operation

Before starting actual operation, perform test operation to make sure that the machine operates normally. Refer to section 4.1 for how to power on and off the servo amplifier.

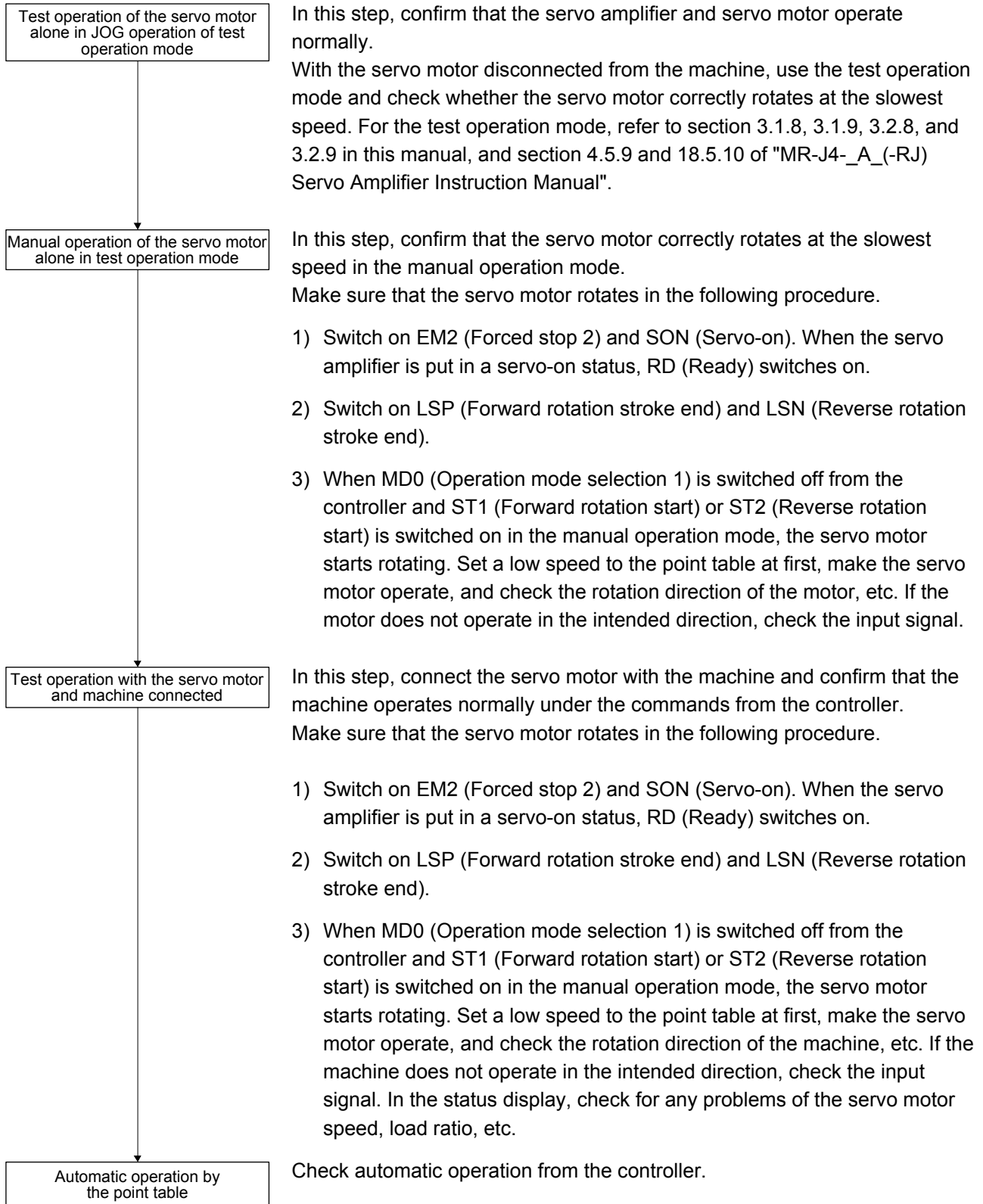

4. HOW TO USE THE POINT TABLE

4.1.4 Parameter setting

POINT
<ul style="list-style-type: none"> ● The following encoder cables are of four-wire type. When using any of these encoder cables, set [Pr. PC22] to "1 ___" to select the four-wire type. Incorrect setting will result in [AL. 16 Encoder initial communication error 1]. MR-EKCBL30M-L MR-EKCBL30M-H MR-EKCBL40M-H MR-EKCBL50M-H ● Assign the following output devices to the CN1-22, CN1-23, and CN1-25 pins with [Pr. PD23], [Pr. PD24], and [Pr. PD26]. CN1-22: CPO (Rough match) CN1-23: ZP (Home position return completion) CN1-25: MEND (Travel completion)

When you use the servo under the point table method, set [Pr. PA01] to "___6" (Positioning mode (point table method)). Under the point table method, the servo can be used by merely changing the basic setting parameters ([Pr. PA __]) and positioning control parameters ([Pr. PT __]) mainly.

Set other parameters as necessary.

The following table shows the necessary setting of [Pr. PA __] and [Pr. PT __] under the point table method.

Operation mode selection item		Parameter setting		Input device setting	
		[Pr. PA01]	[Pr. PT04]	MD0 (Note)	DI0 to DI7 (Note)
Automatic operation mode under point table method	Each positioning operation	___6	___0	On	Set the point table No. to be reached. (Refer to (2) (b) of 4.2.1.)
	Automatic continuous operation				
Manual operation mode	Varying-speed operation	___6	___1	Off	All off
	Automatic continuous positioning operation				
Home position return mode	JOG operation	___6	___2	On	All off
	Manual pulse generator operation				
	Dog type				
	Count type				
	Data set type				
	Stopper type				
	Home position ignorance (servo-on position as home position)				
	Dog type rear end reference				
	Count type front end reference				
	Dog cradle type				
	Dog type last Z-phase reference				
	Dog type front end reference				
Dogless Z-phase reference					

Note. MD0: Operation mode selection 1, DI0 to DI7: Point table No. selection 1 to Point table No. selection 8

4. HOW TO USE THE POINT TABLE

4.1.5 Point table setting

Set the data for operation to the point table. The following shows the items to be set.

Item	Main description
Position data	Set the position data for movement.
Servo motor speed	Set the command speed of the servo motor for execution of positioning.
Acceleration time constant	Set the acceleration time constant.
Deceleration time constant	Set the deceleration time constant.
Dwell	Set the waiting time when performing automatic continuous operation.
Auxiliary function	Set when performing automatic continuous operation.
M code	Outputs the first digit and the second digit of the M code in 4-bit binary respectively.

Refer to section 4.2.2 for details of the point table.

4.1.6 Actual operation

Start actual operation after confirmation of normal operation by test operation and completion of the corresponding parameter settings.

4.1.7 Troubleshooting at start-up

 CAUTION	<p>● Never make a drastic adjustment or change to the parameter values as doing so will make the operation unstable.</p>
--	--

POINT	<p>● Using MR Configurator2, you can refer to the reason for rotation failure, etc.</p>
--------------	---

The following faults may occur at start-up. If any of such faults occurs, take the corresponding action. "MR-J4-_A_" means "MR-J4-_A_(-RJ) Servo Amplifier Instruction Manual".

No.	Start-up sequence	Fault	Investigation	Possible cause	Reference
1	Power on	<ul style="list-style-type: none"> - The 7-segment LED display does not turn on. - The 7-segment LED display flickers. 	Not improved even if CN1, CN2, and CN3 connectors are disconnected.	<ol style="list-style-type: none"> 1. Power supply voltage fault 2. The servo amplifier is malfunctioning. 	/
			Improved when CN1 connector is disconnected.	Power supply of CN1 cabling is shorted.	
			Improved when CN2 connector is disconnected.	<ol style="list-style-type: none"> 1. Power supply of encoder cabling is shorted. 2. Encoder is malfunctioning. 	
		Improved when CN3 connector is disconnected.	Power supply of CN3 cabling is shorted.		
		Alarm occurs.	Refer to chapter 8 and remove the cause.		Chapter 8 (Note)
2	Switch on SON (Servo-on).	Alarm occurs.	Refer to chapter 8 and remove the cause.		Chapter 8 (Note)
		Servo motor shaft is not servo-locked. (Servo motor shaft is free.)	<ol style="list-style-type: none"> 1. Check the display to see if the servo amplifier is ready to operate. 2. Check the external I/O signal indication (section 3.1.7 or 3.2.7) to see if SON (Servo-on) is on. 	<ol style="list-style-type: none"> 1. SON (Servo-on) is not input. (wiring mistake) 2. 24 V DC power is not supplied to DICOM. 	Section 3.1.7 Section 3.2.7

4. HOW TO USE THE POINT TABLE

No.	Start-up sequence	Fault	Investigation	Possible cause	Reference
3	Perform a home position return.	Servo motor does not rotate.	Call the external I/O signal display and check the on/off status of the input signal. (Refer to section 3.1.7 or 3.2.7.)	LSP, LSN, and ST1 are off.	Section 3.1.7 Section 3.2.7
			Check [Pr. PA11 Forward rotation torque limit] and [Pr. PA12 Reverse rotation torque limit].	Torque limit level is too low as compared to the load torque.	Section 7.2.1
			When TLA (Analog torque limit) is usable, check the input voltage on the status display.	Torque limit level is too low as compared to the load torque.	Section 3.1.2 Section 3.2.2
		The home position return is not completed.	Call the external I/O signal display and check the on/off status of input signal DOG. (Refer to section 3.1.7 or 3.2.7.)	The proximity dog is set incorrectly.	Section 3.1.7 Section 3.2.7
4	Switch on ST1 (Forward rotation start) or ST2 (Reverse rotation start).	Servo motor does not rotate.	Call the external I/O signal display (section 3.1.7 or 3.2.7) and check the on/off status of the input signal.	LSP, LSN, ST1, and ST2 are off.	Section 3.1.7 Section 3.2.7
			Check [Pr. PA11 Forward rotation torque limit] and [Pr. PA12 Reverse rotation torque limit].	Torque limit level is too low as compared to the load torque.	Section 7.2.1
			When TLA (Analog torque limit) is usable, check the input voltage on the status display.	Torque limit level is too low as compared to the load torque.	Section 3.1.2 Section 3.2.2
5	Gain adjustment	Rotation ripples (speed fluctuations) are large at low speed.	Make gain adjustment in the following procedure. 1. Increase the auto tuning response level. 2. Repeat acceleration/ deceleration more than three times to complete auto tuning.	Gain adjustment fault	MR-J4- _A_ Chapter 6
		Large load inertia moment causes the servo motor shaft to oscillate side to side.	If the servo motor may be driven with safety, repeat acceleration and deceleration three times or more to complete the auto tuning.	Gain adjustment fault	MR-J4- _A_ Chapter 6

Note. Only a list of alarms and warnings is listed in chapter 8. Refer to "MELSERVO-J4 Servo Amplifier Instruction Manual (Troubleshooting)" for details of alarms and warnings.

4. HOW TO USE THE POINT TABLE

4.2 Automatic operation mode

4.2.1 Automatic operation mode

(1) Command method

Start operation using ST1 (Forward rotation start) or ST2 (Reverse rotation start). Absolute value command method and incremental value command method are provided in automatic operation mode.

(a) Absolute value command method

As position data, set the target address to be reached.

1) Millimeter, inch, and pulse unit

Setting range: -999999 to 999999 [$\times 10^{\text{STM}}$ μm] (STM = Feed length multiplication [Pr. PT03])

-999999 to 999999 [$\times 10^{(\text{STM}-4)}$ inch] (STM = Feed length multiplication [Pr. PT03])

-999999 to 999999 [pulse]

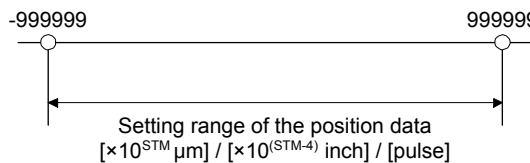

2) Degree unit

Set the target position by indicating the CCW direction with a "+" sign and the CW direction with a "-" sign.

Under the absolute value command method, the rotation direction can be specified with a "+" or "-" sign.

An example of setting is shown below.

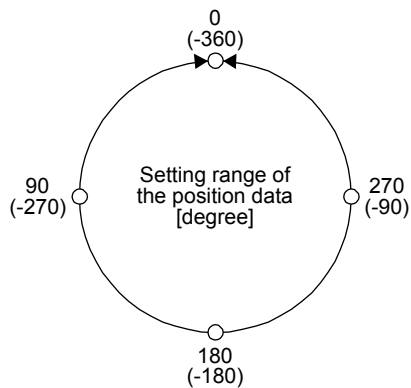

Coordinate system in degrees

- The coordinate is determined by referring to the position of 0 degree.
- + direction: 0 \rightarrow 90 \rightarrow 180 \rightarrow 270 \rightarrow 0
- direction: 0 \rightarrow -90 \rightarrow -180 \rightarrow -270 \rightarrow -360
- The positions of 270 degrees and -90 degrees are the same.
- The positions of 0 degree, 360 degrees and -360 degrees are the same.

The travel direction to the target position is set with [Pr. PT03].

[Pr. PT03] setting	Servo motor rotation direction
_ 0 _ _	The servo motor rotates to the target position in a direction specified with a sign of the position data.
_ 1 _ _	The servo motor rotates from the current position to the target position in the shorter direction. If the distances from the current position to the target position are the same for CCW and CW, the servo motor rotates in the CCW direction.

4. HOW TO USE THE POINT TABLE

a) When using the Rotation direction specifying ([Pr. PT03] = "_ 0 _")

When the position data of 270.000 degrees is specified, the servo motor rotates in the CCW direction.

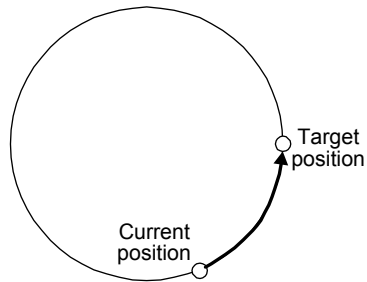

When the position data of -90.000 degrees is specified, the servo motor rotates in the CW direction.

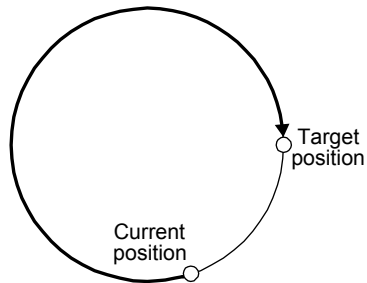

When the position data of -360.000 degrees is specified, the servo motor rotates in the CW direction. (A)

When you specify 360.000 degrees or 0 degree to the position data, the servo motor rotates in the CCW direction. (B)

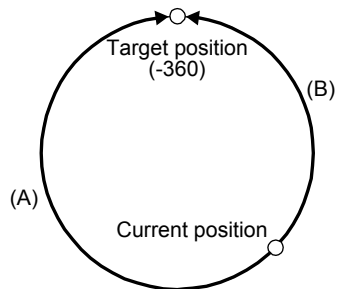

4. HOW TO USE THE POINT TABLE

b) When using the shortest rotation specification ([Pr. PT03] = _ 1 _ _)

When the position data of 270.000 degrees is specified, the servo motor rotates in the CCW direction.

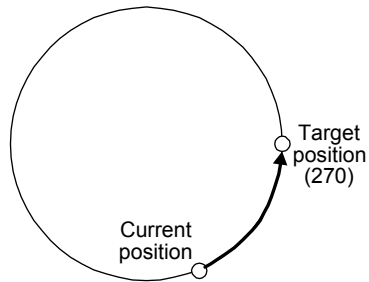

When the position data of -90.000 degrees is specified, the servo motor rotates in the CCW direction.

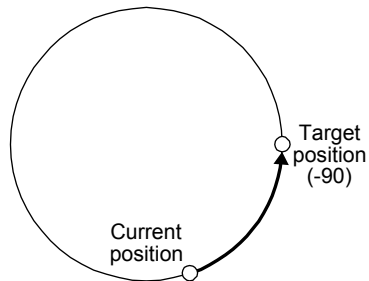

If the position data of 270.000 degrees is specified when the current position is at 90, the distances in the CCW and CW are the same. In such a case, the servo motor rotates in the CCW direction.

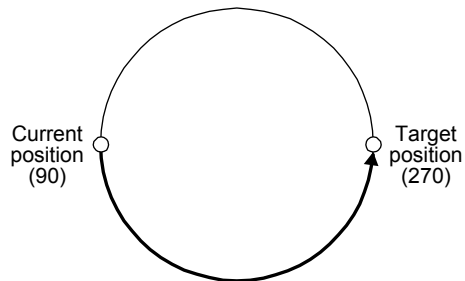

4. HOW TO USE THE POINT TABLE

(b) Incremental value command method

As position data, set the travel distance from the current address to the target address.

1) Millimeter, inch, and pulse unit

Setting range: 0 to 999999 [$\times 10^{\text{STM}}$ μm] (STM = Feed length multiplication [Pr. PT03])
0 to 999999 [$\times 10^{(\text{STM}-4)}$ inch] (STM = Feed length multiplication [Pr. PT03])
0 to 999999 [pulse]

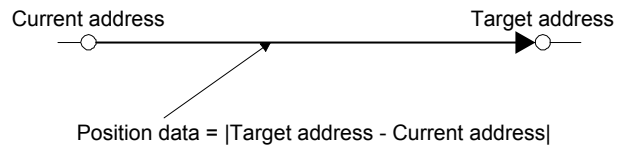

2) Degree unit

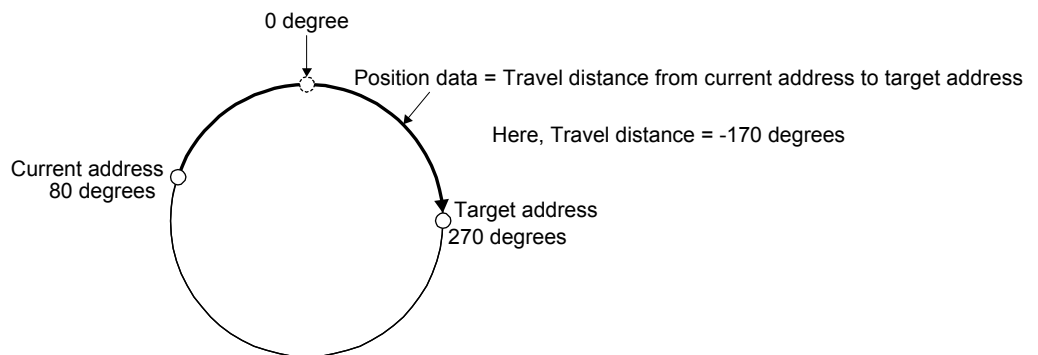

4. HOW TO USE THE POINT TABLE

(2) Point table

(a) Point table setting

1 to 255 point tables can be set. To use point table No. 16 to 255, enable DI4 (Point table No. selection 5) to DI7 (Point table No. selection 8) with "Device Setting" on MR Configurator2.

Set point tables using MR Configurator2 or the operation section of the servo amplifier.

The following table lists what to set. Refer to section 4.2.2 for details of the settings.

Item	Main description
Position data	Set the position data for movement.
Servo motor speed	Set the command speed of the servo motor for execution of positioning.
Acceleration time constant	Set the acceleration time constant.
Deceleration time constant	Set the deceleration time constant.
Dwell	Set the waiting time when performing automatic continuous operation.
Auxiliary function	Set when performing automatic continuous operation.
M code	Outputs the first digit and the second digit of the M code in 4-bit binary respectively.

(b) Selection of point tables

Using the input signal or the communication function, select the point table No. with the communication command from the controller such as a personal computer.

The following table lists the point table No. selected in response to the input signal and the communication command.

However, when using the input signal to select the point table No., you can only use point table No. 1 to 15 in the initial status.

To use point table No. 16 to 255, enable input signals DI4 (Point table No. selection 5) to DI7 (Point table No. selection 8) with "Device Setting" on MR Configurator2.

When using the communication function to select the point table No., refer to chapter 10.

Input signal (Note)								Selected point table No.
DI7	DI6	DI5	DI4	DI3	DI2	DI1	DI0	
0	0	0	0	0	0	0	0	0 (for home position return)
0	0	0	0	0	0	0	1	1
0	0	0	0	0	0	1	0	2
0	0	0	0	0	0	1	1	3
0	0	0	0	0	1	0	0	4
.
.
.
1	1	1	1	1	1	1	0	254
1	1	1	1	1	1	1	1	255

Note. 0: Off

1: On

4. HOW TO USE THE POINT TABLE

4.2.2 Automatic operation using point table

(1) Absolute value command method

This method allows to select absolute value command or incremental value command with the auxiliary function of the point table.

(a) Point table

Set the point table values using MR Configurator2 or the operation section.

Set the position data, servo motor speed, acceleration time constant, deceleration time constant, dwell and auxiliary function to the point table.

To use the point table under the absolute value command method, set "0", "1", "8", or "9" to the auxiliary function. To use the point table under the incremental value command method, set "2", "3", "10", or "11" to the auxiliary function.

When you set a value outside this range to the point table, the set value will be clamped with the maximum or minimum value. When changing the command unit or the connected motor results in the set value outside this range, [AL. 37] will occur.

Item	Setting range	Unit	Description
Position data	-999999 to 999999 (Note 1)	$\times 10^{\text{STM}}$ μm $\times 10^{(\text{STM}-4)}$ inch $\times 10^{-3}$ degree pulse	(1) When using this point table under the absolute value command method Set the target address (absolute value). The teaching function is available for setting this value. (2) When using this point table under the incremental value command method Set the travel distance. A "-" sign indicates a reverse rotation command. The teaching function is not available. When teaching is executed, the setting will not be completed.
Servo motor speed	0 to permissible speed	r/min mm/s (Note 2)	Set the command speed of the servo motor for execution of positioning. The setting value must be within the permissible instantaneous speed of the servo motor used.
Acceleration time constant	0 to 20000	ms	Set a time until the servo motor rotates at the rated speed.
Deceleration time constant	0 to 20000	ms	Set a time from when the servo motor rotates at the rated speed until when the motor stops.
Dwell	0 to 20000	ms	Set the dwell. To disable the dwell, set "0" or "2" to the auxiliary function. To perform varying-speed operation, set "1", "3", "8", "9", "10" or "11" to the auxiliary function and 0 to the dwell. When the dwell is set, the position command of the selected point table is completed, and after the set dwell has elapsed, the position command of the next point table is started.

4. HOW TO USE THE POINT TABLE

Item	Setting range	Unit	Description
Auxiliary function	0 to 3, 8 to 11		<p>Set the auxiliary function.</p> <p>(1) When using this point table under the absolute value command method</p> <p>0: Automatic operation is performed in accordance with a single point table selected.</p> <p>1: Automatic continuous operation is performed to the next point table without a stop.</p> <p>8: Automatic continuous operation is performed without a stop to the point table selected at start-up.</p> <p>9: Automatic continuous operation is performed without stopping a point table No. 1.</p> <p>(2) When using this point table under the incremental value command method</p> <p>2: Automatic operation is performed in accordance with a single point table selected.</p> <p>3: Automatic continuous operation is performed to the next point table without a stop.</p> <p>10: Automatic continuous operation is performed to the point table selected at start-up.</p> <p>11: Automatic continuous operation is performed without stopping a point table No. 1.</p> <p>When a different rotation direction is set, smoothing zero (command output) is confirmed and then the rotation direction is reversed.</p> <p>Setting "1" or "3" to point table No. 255 results in an error.</p> <p>Refer to (3) (b) of this section.</p>
M code	0 to 99		Outputs the first digit and the second digit of the M code in 4-bit binary respectively.

- Note
1. The setting range of the position data in degrees is -360.000 to 360.000. When the unit of the position data is μm or inch, the location of the decimal point is changed according to the STM setting.
 2. The unit will be "mm/s" for the linear servo motor control mode.

(b) Parameter setting

Set the following parameters to perform automatic operation.

1) Command method selection ([Pr. PT01])

Select the absolute value command method as shown below.

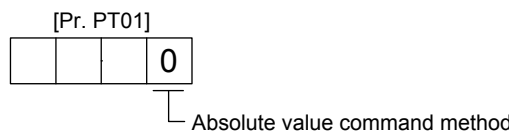

2) Rotation direction selection ([Pr. PA14])

Select the servo motor rotation direction when ST1 (Forward rotation start) is switched on.

[Pr. PA14] setting	Servo motor rotation direction when ST1 (Forward rotation start) is switched on
0	CCW rotation with + position data CW rotation with - position data
1	CW rotation with + position data CCW rotation with - position data

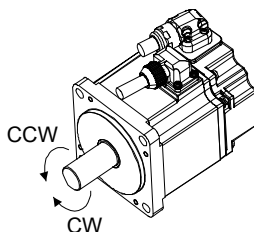

4. HOW TO USE THE POINT TABLE

3) Position data unit ([Pr. PT01])

Set the unit of the position data.

[Pr. PT01] setting	Position data unit
_ 0 _	mm
_ 1 _	inch
_ 2 _	degree
_ 3 _	pulse

4) Feed length multiplication ([Pr. PT03])

Set the feed length multiplication (STM) of the position data.

[Pr. PT03] setting	Position data input range			
	[mm]	[inch]	[degree] (Note 1)	[pulse] (Note 1)
___ 0	- 999.999 to + 999.999	- 99.9999 to + 99.9999	- 360.000 to + 360.000 (Note 2)	- 999999 to + 999999
___ 1	- 9999.99 to + 9999.99	- 999.999 to + 999.999		
___ 2	- 99999.9 to + 99999.9	- 9999.99 to + 9999.99		
___ 3	- 999999 to + 999999	- 99999.9 to + 99999.9		

Note 1. The feed length multiplication setting ([Pr. PT03]) is not applied to the unit multiplication factor.

Adjust the unit multiplication factor in the electronic gear setting ([Pr. PA06] and [Pr. PA07]).

2. The "-" sign has different meanings under the absolute value command method and the incremental value command method. Refer to section 4.2.1 for details.

(c) Operation

Selecting DI0 to DI7 for the point table and switching on ST1 starts positioning to the position data at the set speed, acceleration time constant and deceleration time constant. At this time, ST2 (Reverse rotation start) is invalid.

Item	Used device	Description
Automatic operation mode selection	MD0 (Operation mode selection 1)	Switch on MD0.
Point table selection	DI0 (Point table No. selection 1) DI1 (Point table No. selection 2) DI2 (Point table No. selection 3) DI3 (Point table No. selection 4) DI4 (Point table No. selection 5) DI5 (Point table No. selection 6) DI6 (Point table No. selection 7) DI7 (Point table No. selection 8)	Refer to (2) (b) of 4.2.1.
Start	ST1 (Forward rotation start)	Switch on ST1 to start.

4. HOW TO USE THE POINT TABLE

(2) Incremental value command method

(a) Point table

Set the point table values using MR Configurator2 or the operation section.

Set the position data, servo motor speed, acceleration time constant, deceleration time constant, dwell and auxiliary function to the point table.

When you set a value outside the setting range to the point table, the set value will be clamped with the maximum or minimum value. When changing the command unit or the connected motor results in the set value outside the setting range, [AL. 37] will occur.

Item	Setting range	Unit	Description
Position data	0 to 999999 (Note 1)	$\times 10^{\text{STM}}$ μm $\times 10^{(\text{STM}-4)}$ inch $\times 10^{-3}$ degree pulse	Set the travel distance. The teaching function is not available. When teaching is executed, the setting will not be completed. The unit can be changed by [Pr. PT03] (Feed length multiplication).
Servo motor speed	0 to permissible speed	r/min mm/s (Note 2)	Set the command speed of the servo motor for execution of positioning. The setting value must be the permissible instantaneous speed or less of the servo motor used.
Acceleration time constant	0 to 20000	ms	Set a time until the servo motor rotates at the rated speed.
Deceleration time constant	0 to 20000	ms	Set a time from when the servo motor rotates at the rated speed until when the motor stops.
Dwell	0 to 20000	ms	Set the dwell. To disable the dwell, set "0" to the auxiliary function. To perform varying-speed operation, set "1", "8" or "9" to the auxiliary function and 0 to the dwell. When the dwell is set, the position command of the selected point table is completed, and after the set dwell has elapsed, the position command of the next point table is started.
Auxiliary function	0, 1, 8 to 9		Set the auxiliary function. 0: Automatic operation is performed in accordance with a single point table selected. 1: Automatic continuous operation is performed to the next point table without a stop. 8: Automatic continuous operation is performed without a stop to the point table selected at start-up. 9: Automatic continuous operation is performed without stopping a point table No. 1. Refer to section 4.2.2 for details.
M code	0 to 99		Outputs the first digit and the second digit of the M code in 4-bit binary respectively.

Note 1. The setting range of the position data in degrees is 0 to 999.999. When the unit of the position data is μm or inch, the location of the decimal point is changed according to the STM setting.

2. The unit will be "mm/s" for the linear servo motor control mode.

4. HOW TO USE THE POINT TABLE

(b) Parameter setting

Set the following parameters to perform automatic operation.

1) Command method selection ([Pr. PT01])

Select the incremental value command method as shown below.

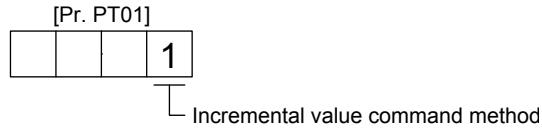

2) Rotation direction selection ([Pr. PA14])

Select the servo motor rotation direction when ST1 (Forward rotation start) or ST2 (Reverse rotation start) is switched on.

[Pr. PA14] setting	Servo motor rotation direction	
	ST1 (Forward rotation start)	ST2 (Reverse rotation start)
0	CCW rotation (address increase)	CW rotation (address decrease)
1	CW rotation (address increase)	CCW rotation (address decrease)

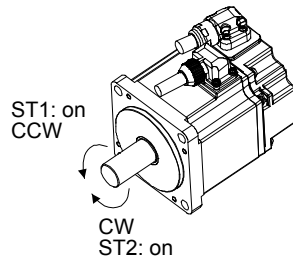

[Pr. PA14]: 0

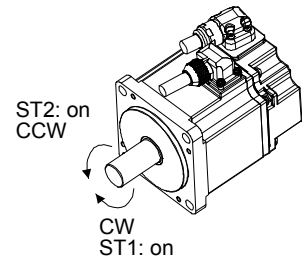

[Pr. PA14]: 1

3) Position data unit ([Pr. PT01])

Set the unit of the position data.

[Pr. PT01] setting	Position data unit
_ 0 _	mm
_ 1 _	inch
_ 2 _	degree
_ 3 _	pulse

4) Feed length multiplication ([Pr. PT03])

Set the feed length multiplication (STM) of the position data.

[Pr. PT03] setting	Position data input range			
	[mm]	[inch]	[degree] (Note)	[pulse] (Note)
___ 0	0 to + 999.999	0 to + 99.9999	0 to + 999.999	0 to + 999999
___ 1	0 to + 9999.99	0 to + 999.999		
___ 2	0 to + 99999.9	0 to + 9999.99		
___ 3	0 to + 999999	0 to + 99999.9		

Note. The feed length multiplication setting ([Pr. PT03]) is not applied to the unit multiplication factor.

Adjust the unit multiplication factor in the electronic gear setting ([Pr. PA06] and [Pr. PA07]).

4. HOW TO USE THE POINT TABLE

(c) Operation

Selecting DI0 to DI7 for the point table and switching on ST1 starts a forward rotation of the motor over the travel distance of the position data at the set speed, acceleration time constant and deceleration time constant.

Switching on ST2 starts a reverse rotation of the motor in accordance with the values set to the selected point table.

When the positioning operation is performed consecutively under the incremental value command method, the servo motor rotates in the same direction only.

To change the travel direction during continuous operation, perform the operation under the absolute value command method.

Item	Used device	Description
Automatic operation mode selection	MD0 (Operation mode selection 1)	Switch on MD0.
Point table selection	DI0 (Point table No. selection 1) DI1 (Point table No. selection 2) DI2 (Point table No. selection 3) DI3 (Point table No. selection 4) DI4 (Point table No. selection 5) DI5 (Point table No. selection 6) DI6 (Point table No. selection 7) DI7 (Point table No. selection 8)	Refer to (2) (b) of 4.2.1.
Start	ST1 (Forward rotation start) ST2 (Reverse rotation start)	Switch on ST1 to start. Switch on ST2 to start.

4. HOW TO USE THE POINT TABLE

(3) Automatic operation timing chart

(a) Automatic individual positioning operation

1) Absolute value command method ([Pr. PT01] = ___ 0)

While the servo motor is stopped under servo-on state, switching on ST1 (Forward rotation start) starts the automatic positioning operation.

The following shows a timing chart.

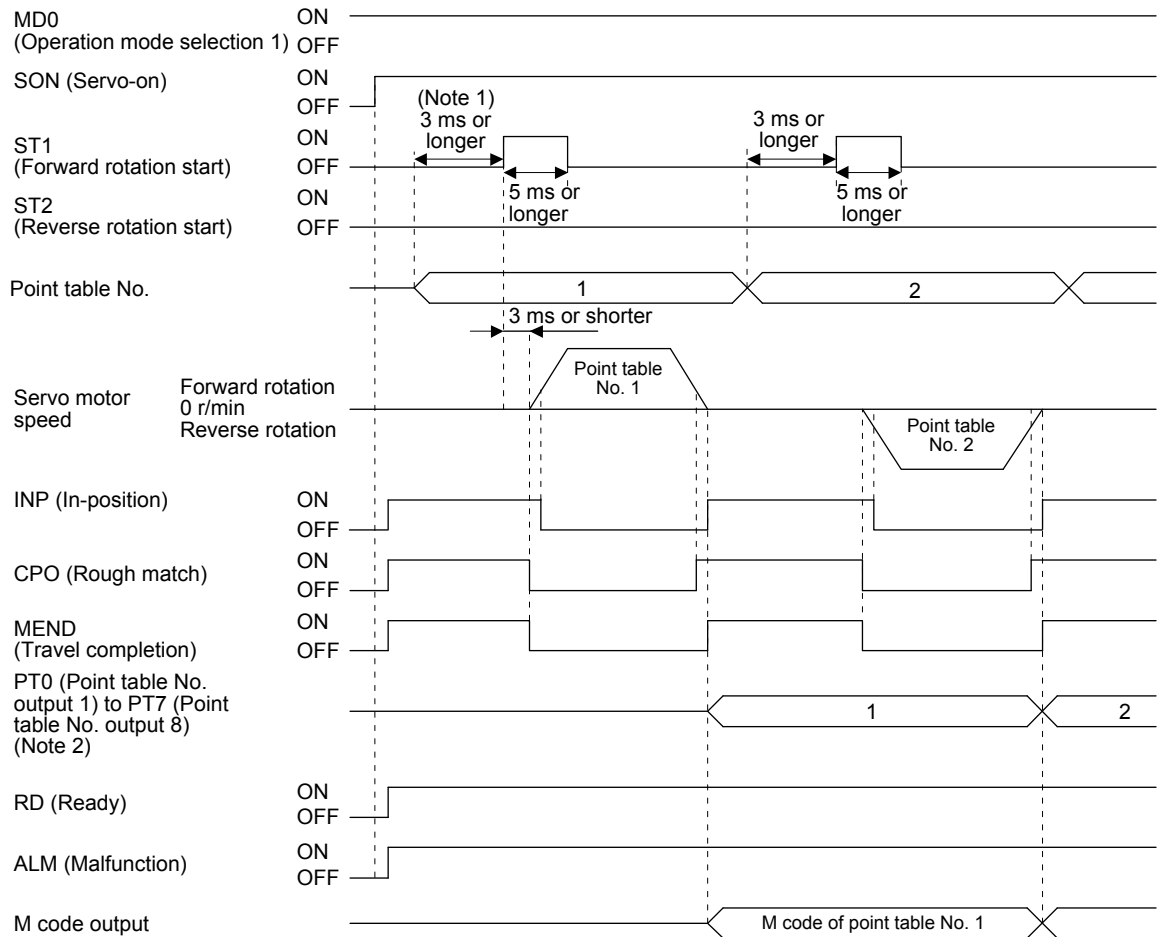

Note 1. The detection of external input signals is delayed by the set time in the input filter setting of [Pr. PD29].

Considering the output signal sequence from the controller and signal variations due to hardware, configure a sequence that changes the point table selection earlier.

2. For MR-J4-03A6-RJ servo amplifiers, up to six points of DO are available; therefore, PT0 to PT7 cannot be outputted simultaneously.

4. HOW TO USE THE POINT TABLE

2) Incremental value command method ([Pr. PT01] = ___ 1)

While the servo motor is stopped under servo-on state, switching on ST1 (Forward rotation start) or ST2 (Reverse rotation start) starts the automatic positioning operation.

The following shows a timing chart.

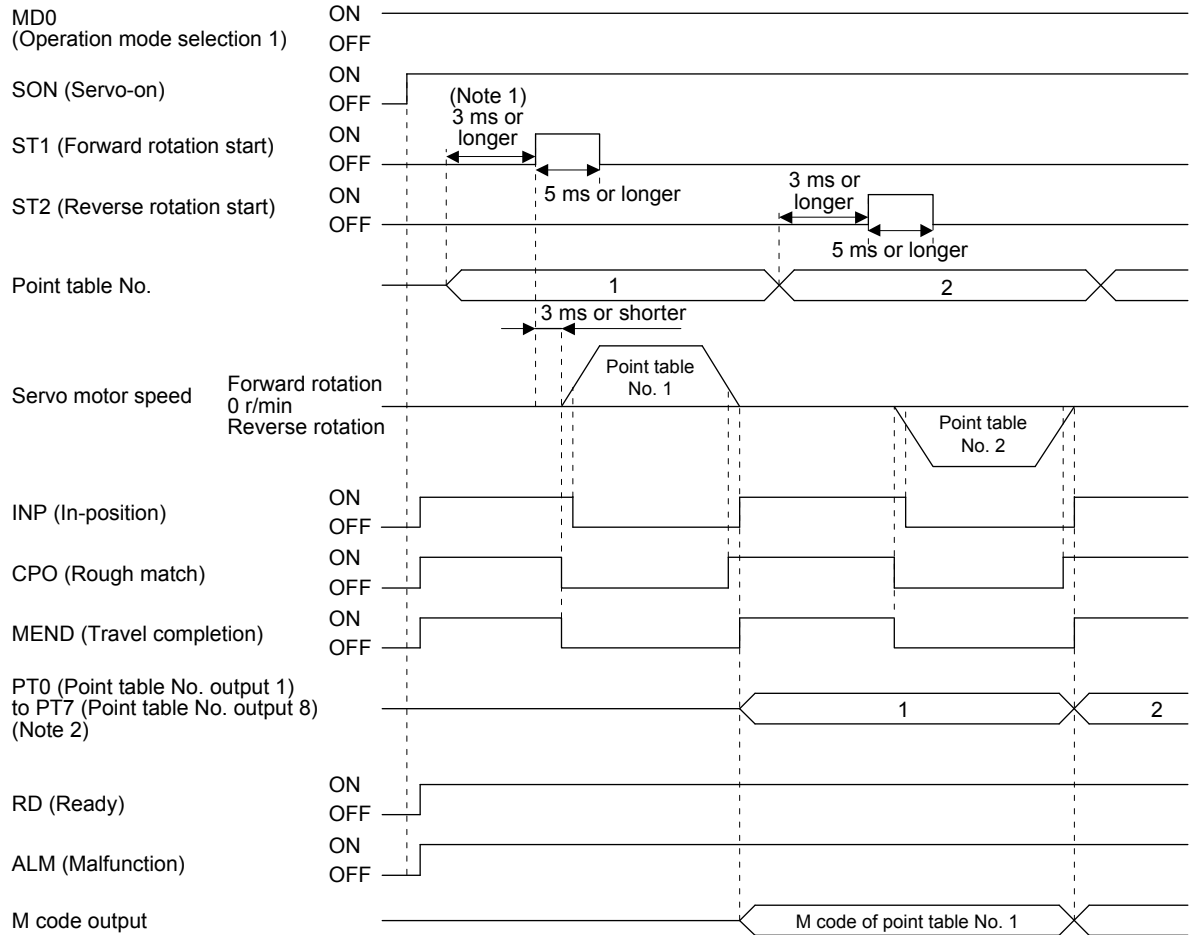

- Note 1. The detection of external input signals is delayed by the set time in the input filter setting of [Pr. PD29]. Considering the output signal sequence from the controller and signal variations due to hardware, configure a sequence that changes the point table selection earlier.
- Note 2. For MR-J4-03A6-RJ servo amplifiers, up to six points of DO are available; therefore, PT0 to PT7 cannot be outputted simultaneously.

4. HOW TO USE THE POINT TABLE

(b) Automatic continuous positioning operation

By merely selecting a point table and switching on ST1 (Forward rotation start) or ST2 (Reverse rotation start), the operation can be performed in accordance with the point tables having consecutive numbers.

1) Absolute value command method ([Pr. PT01] = ___ 0)

By specifying the absolute value command or the incremental value command in the auxiliary function of the point table, the automatic continuous operation can be performed.

The following shows how to set.

Point table setting		
Dwell	Auxiliary function	
	When position data is absolute value	When position data is incremental value
1 or more	1	3

a) Positioning in a single direction

The following shows an operation example with the set values listed in the table below.

In this example, point table No. 1 and point table No. 3 are under the absolute value command method, and point table No. 2 is under the incremental value command method.

Point table No.	Position data [10 ^{STM} μm]	Servo motor speed [r/min]	Acceleration time constant [ms]	Deceleration time constant [ms]	Dwell [ms]	Auxiliary function	M code
1	5.00	3000	100	150	100	1	05
2	5.00	2000	150	200	200	3	10
3	15.00	1000	300	100	Disabled	0 (Note)	15

Note. Always set "0" or "2" to the auxiliary function of the last point table among the consecutive point tables.

0: When using the point table under the absolute value command method

2: When using the point table under the incremental value command method

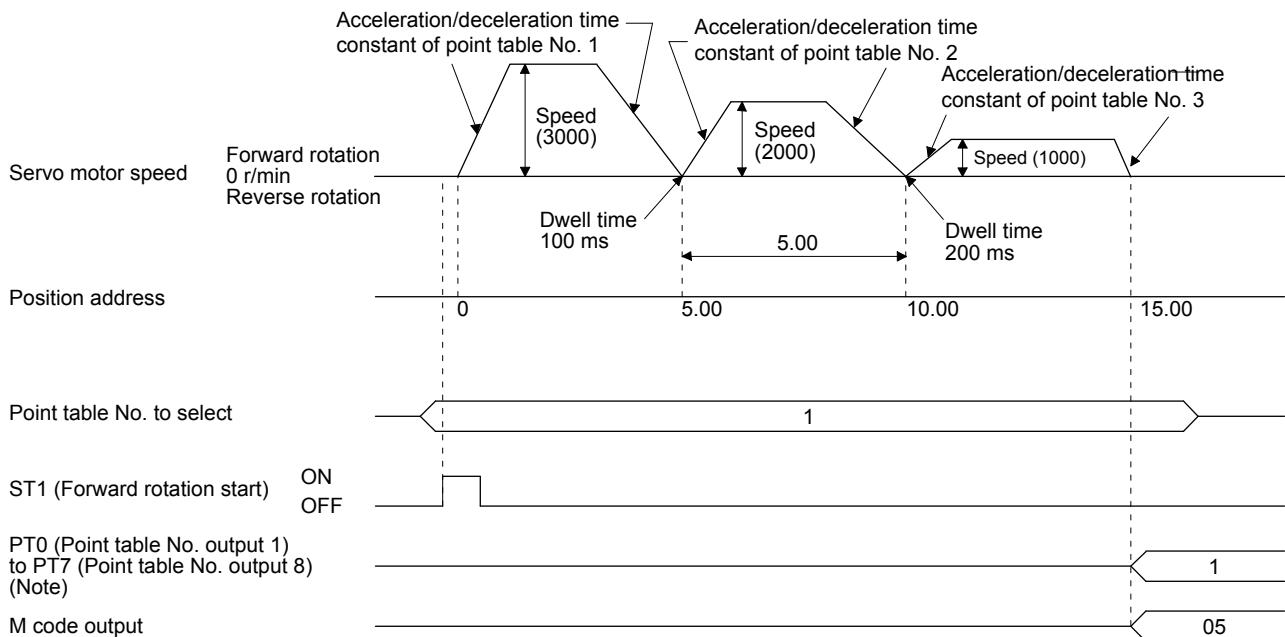

Note. For MR-J4-03A6-RJ servo amplifiers, up to six points of DO are available; therefore, PT0 to PT7 cannot be outputted simultaneously.

4. HOW TO USE THE POINT TABLE

b) Positioning in the reverse direction midway

The following shows an operation example with the set values listed in the table below.

In this example, point table No. 1 and point table No. 3 are under the absolute value command method, and point table No. 2 is under the incremental value command method.

Point table No.	Position data [10 ⁵ μm]	Servo motor speed [r/min]	Acceleration time constant [ms]	Deceleration time constant [ms]	Dwell [ms]	Auxiliary function	M code
1	5.00	3000	100	150	100	1	05
2	7.00	2000	150	200	200	3	10
3	8.00	1000	300	100	Disabled	0 (Note)	15

Note. Always set "0" or "2" to the auxiliary function of the last point table among the consecutive point tables.

0: When using the point table under the absolute value command method

2: When using the point table under the incremental value command method

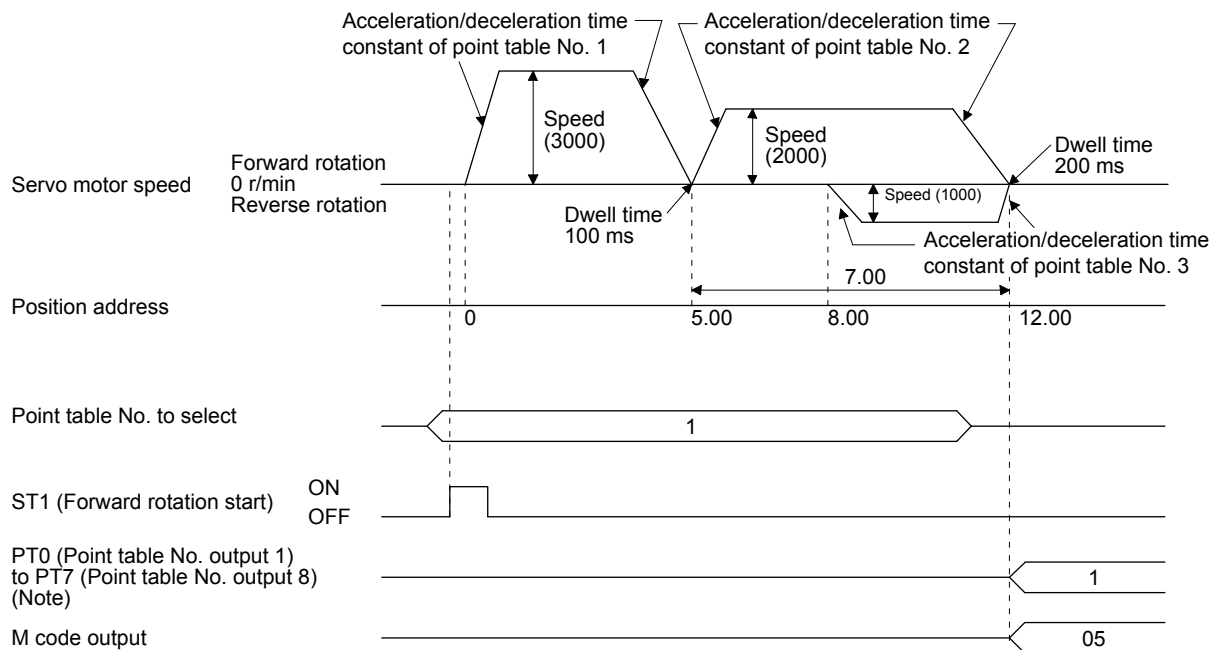

Note. For MR-J4-03A6-RJ servo amplifiers, up to six points of DO are available; therefore, PT0 to PT7 cannot be outputted simultaneously.

4. HOW TO USE THE POINT TABLE

c) Position data in degrees

The following shows an operation example with the set values listed in the table below.

In this example, point table No. 1, point table 2, and point table No. 4 are under the absolute value command method, and point table No. 3 is under the incremental value command method.

Point table No.	Position data [degree]	Servo motor speed [r/min]	Acceleration time constant [ms]	Deceleration time constant [ms]	Dwell [ms]	Auxiliary function	M code
1	120.000	1000	100	150	100	1	05
2	-320.000	500	150	100	200	1	10
3	-230.000	3000	200	300	150	3	15
4	70.000	1500	300	100	Disabled	0 (Note)	20

Note. Always set "0" or "2" to the auxiliary function of the last point table among the consecutive point tables.

- 0: When using the point table under the absolute value command method
- 2: When using the point table under the incremental value command method

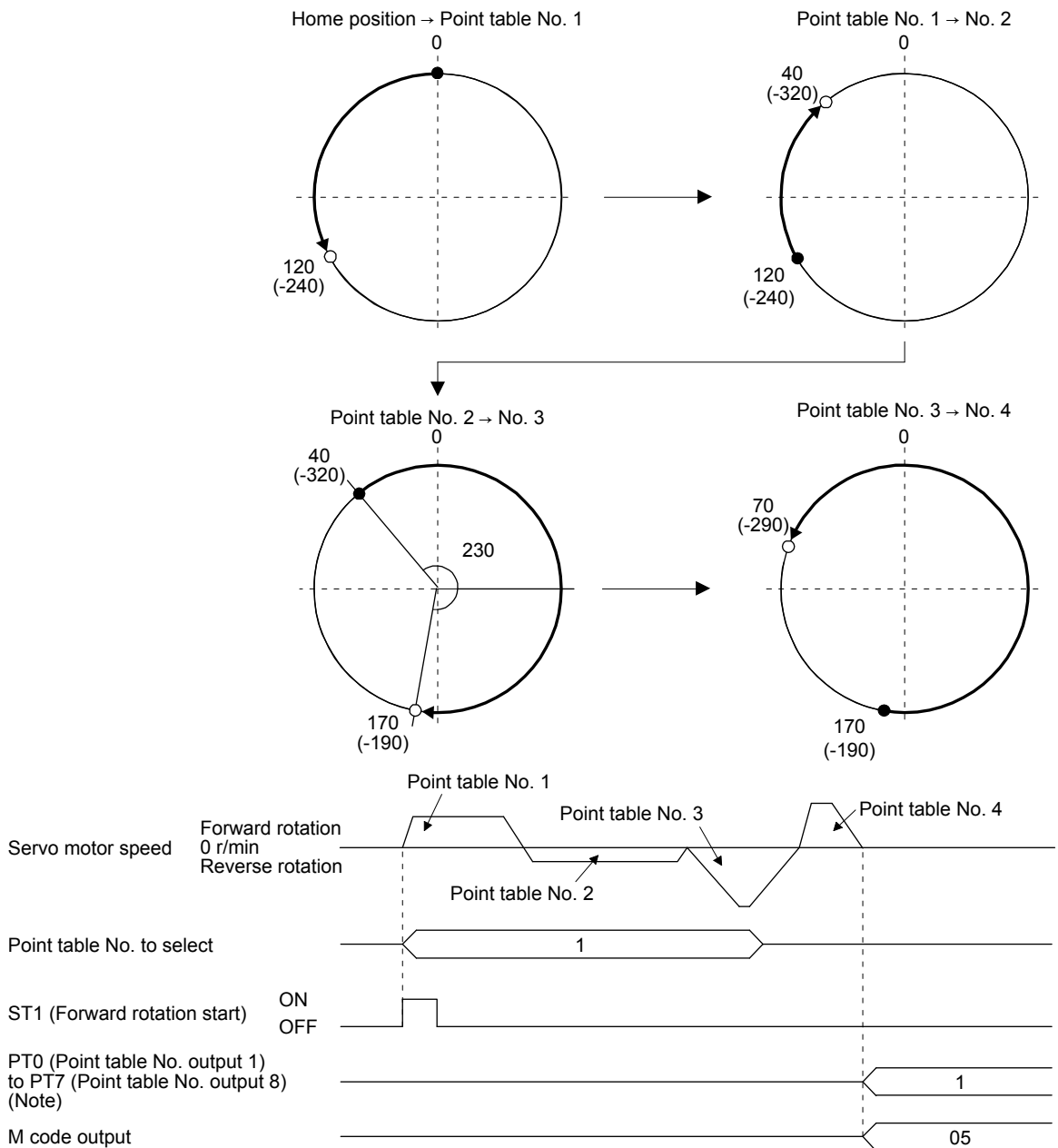

Note. For MR-J4-03A6-RJ servo amplifiers, up to six points of DO are available; therefore, PT0 to PT7 cannot be outputted simultaneously.

4. HOW TO USE THE POINT TABLE

2) Incremental value command method ([Pr. PT01] = ___ 1)

The position data of the incremental value command method is the sum of the position data of consecutive point tables.

The following shows how to set.

Point table setting	
Dwell	Auxiliary function
1 or more	1

a) Positioning in a single direction

The following shows an operation example with the set values listed in the table below.

Point table No.	Position data [10 ^{STM} μm]	Servo motor speed [r/min]	Acceleration time constant [ms]	Deceleration time constant [ms]	Dwell [ms]	Auxiliary function	M code
1	5.00	3000	100	150	100	1	05
2	6.00	2000	150	200	200	1	10
3	3.00	1000	300	100	Disabled	0 (Note)	15

Note. Always set "0" to the auxiliary function of the last point table among the consecutive point tables.

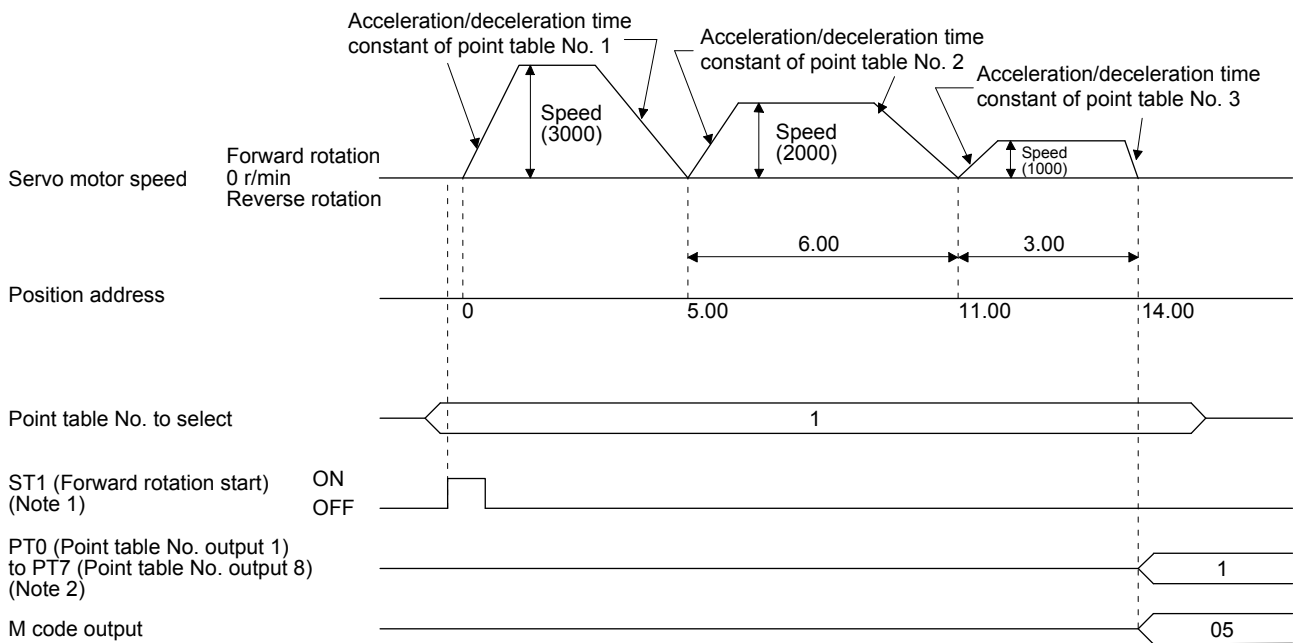

Note 1. Switching on ST2 (Reverse rotation start) starts positioning in the reverse rotation direction.

Note 2. For MR-J4-03A6-RJ servo amplifiers, up to six points of DO are available; therefore, PT0 to PT7 cannot be outputted simultaneously.

4. HOW TO USE THE POINT TABLE

b) Position data in degrees

The following shows an operation example with the set values listed in the table below.

Point table No.	Position data [degree]	Servo motor speed [r/min]	Acceleration time constant [ms]	Deceleration time constant [ms]	Dwell [ms]	Auxiliary function	M code
1	120.000	3000	100	150	0	1	05
2	60.000	1500	150	100	0	1	10
3	90.000	1000	300	100	Disabled	0 (Note)	15

Note. Always set "0" or "2" to the auxiliary function of the last point table among the consecutive point tables.

- 0: When using the point table under the absolute value command method
- 2: When using the point table under the incremental value command method

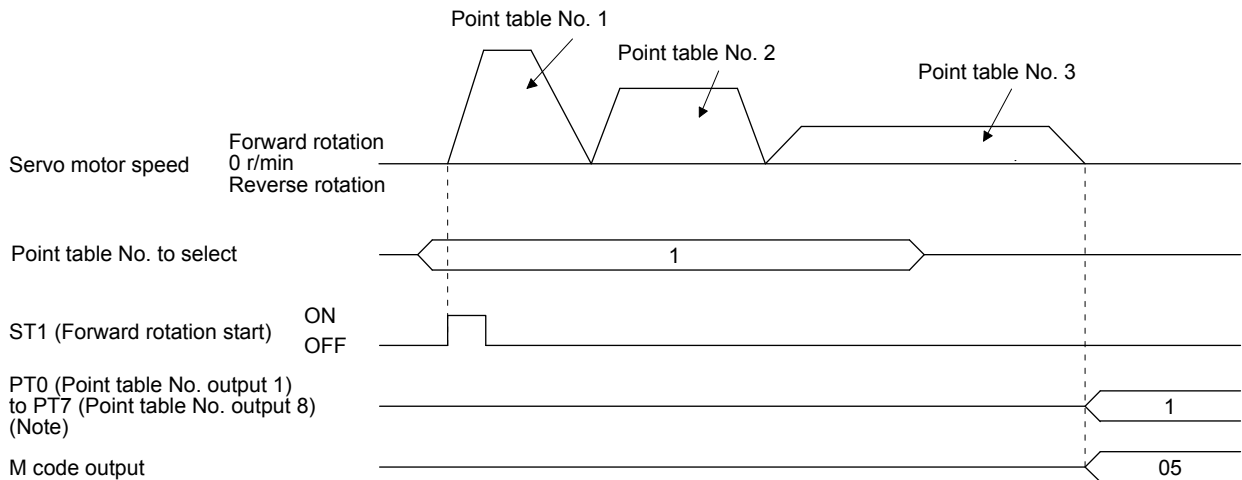
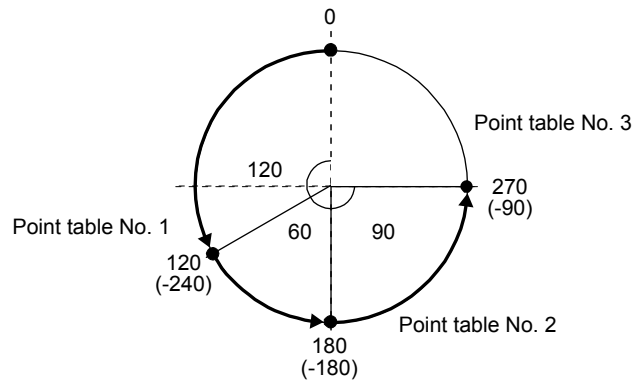

Note. For MR-J4-03A6-RJ servo amplifiers, up to six points of DO are available; therefore, PT0 to PT7 cannot be outputted simultaneously.

4. HOW TO USE THE POINT TABLE

(c) Varying-speed operation

By setting the auxiliary function of the point table, the servo motor speed during positioning can be changed. Point tables are used by the number of the set speed.

1) Absolute value command method ([Pr. PT01] = __ _ 0)

Set "1" or "3" to the auxiliary function to execute the positioning at the speed set in the following point table.

At this time, the position data selected at start is valid, and the acceleration/deceleration time constant set in the next and subsequent point tables is invalid.

By setting "1" or "3" to sub functions until point table No. 254, the operation can be performed at maximum 255 speeds.

Always set "0" or "2" to the auxiliary function of the last point table.

To perform varying-speed operation, always set "0" to the dwell.

Setting "1" or more will enables the automatic continuous positioning operation.

The following table shows an example of setting.

Point table No.	Dwell [ms] (Note 1)	Auxiliary function	Varying-speed operation
1	0	1	Consecutive point table data
2	0	3	
3	Disabled	0 (Note 2)	
4	0	3	Consecutive point table data
5	0	1	
6	Disabled	2 (Note 2)	

Note 1. Always set "0".

2. Always set "0" or "2" to the auxiliary function of the last point table among the consecutive point tables.

4. HOW TO USE THE POINT TABLE

a) Positioning in a single direction

The following shows an operation example with the set values listed in the table below.

In this example, point table No. 1 and point table No. 3 are under the absolute value command method, and point table No. 2 is under the incremental value command method.

Point table No.	Position data [10 ⁵ μm]	Servo motor speed [r/min]	Acceleration time constant [ms]	Deceleration time constant [ms]	Dwell [ms] (Note 1)	Auxiliary function	M code
1	5.00	3000	100	150	0	1	05
2	3.00	2000	Disabled	Disabled	0	3	10
3	10.00	1000	Disabled	Disabled	0	1	15
4	6.00	500	Disabled	Disabled	Disabled	2 (Note 2)	20

Note 1. Always set "0".

2. Always set "0" or "2" to the auxiliary function of the last point table among the consecutive point tables.

0: When using the point table under the absolute value command method

2: When using the point table under the incremental value command method

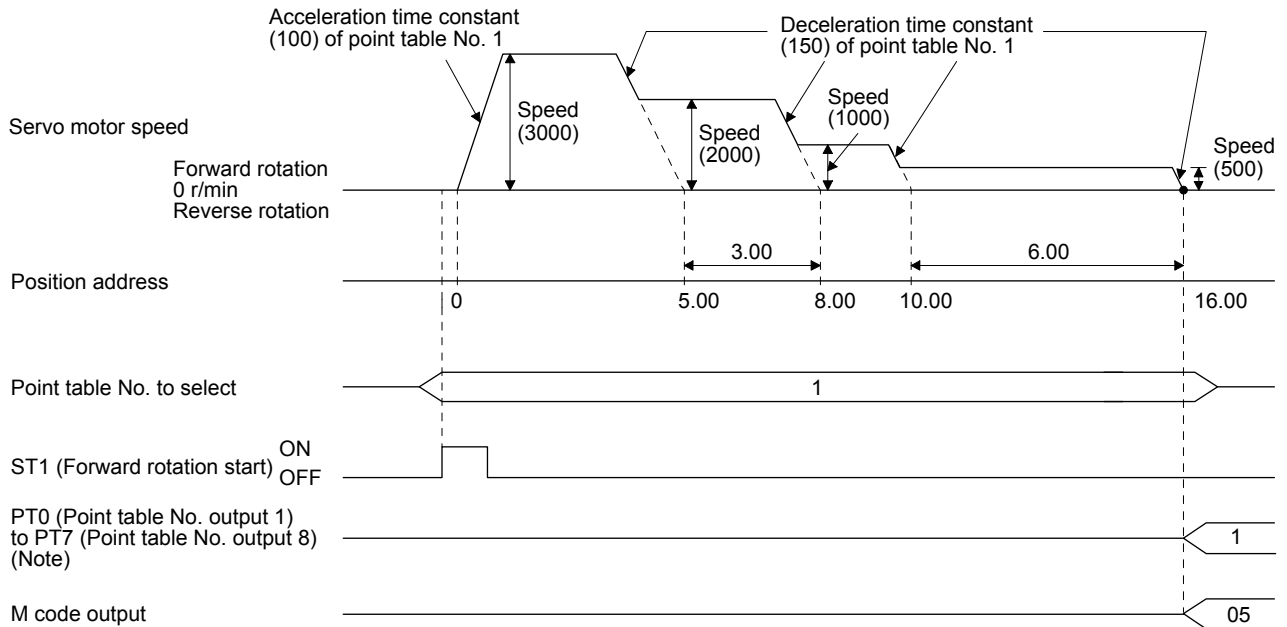

Note. For MR-J4-03A6-RJ servo amplifiers, up to six points of DO are available; therefore, PT0 to PT7 cannot be outputted simultaneously.

4. HOW TO USE THE POINT TABLE

b) Positioning in the reverse direction midway

The following shows an operation example with the set values listed in the table below.

In this example, point table No. 1 and point table No. 3 are under the absolute value command method, and point table No. 2 is under the incremental value command method.

Point table No.	Position data [10 ⁵ μm]	Servo motor speed [r/min]	Acceleration time constant [ms]	Deceleration time constant [ms]	Dwell [ms] (Note 1)	Auxiliary function	M code
1	5.00	3000	100	150	0	1	05
2	7.00	2000	Disabled	Disabled	0	3	10
3	8.00	1000	Disabled	Disabled	Disabled	0 (Note 2)	15

Note 1. Always set "0".

2. Always set "0" or "2" to the auxiliary function of the last point table among the consecutive point tables.

0: When using the point table under the absolute value command method

2: When using the point table under the incremental value command method

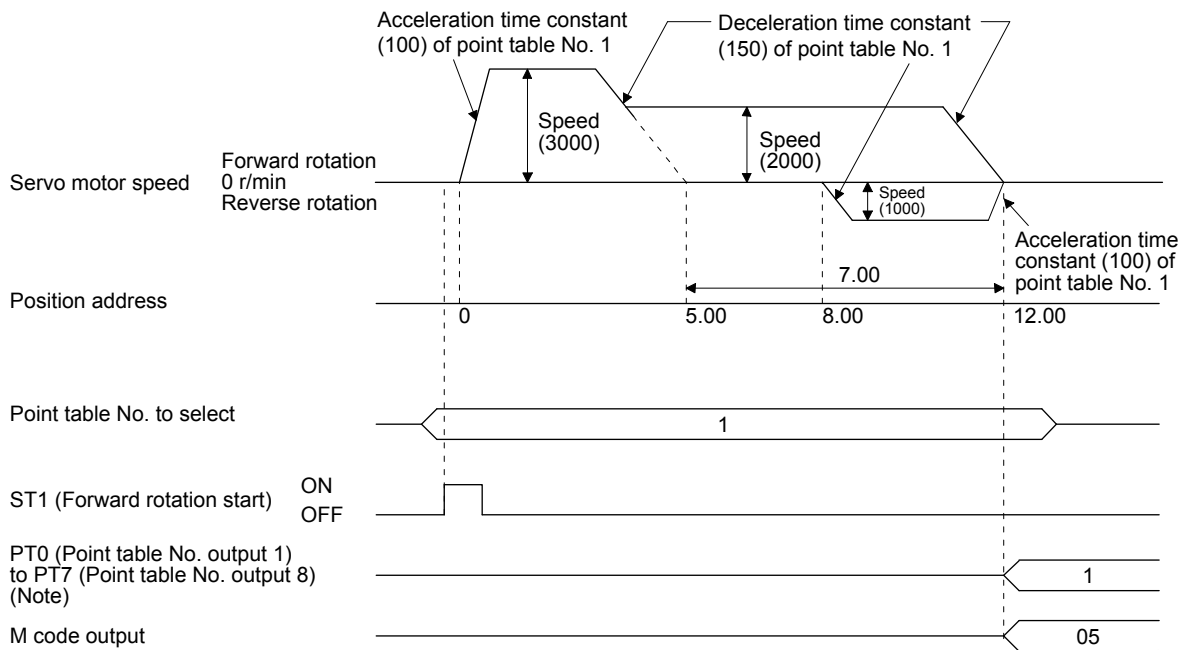

Note. For MR-J4-03A6-RJ servo amplifiers, up to six points of DO are available; therefore, PT0 to PT7 cannot be outputted simultaneously.

4. HOW TO USE THE POINT TABLE

2) Incremental value command method ([Pr. PT01] = ___ 1)

Setting "1" to the auxiliary function executes positioning at the speed set in the following point table.

At this time, the position data selected at start is valid, and the acceleration/deceleration time constant set in the next and subsequent point tables is invalid.

By setting "1" to sub functions until point table No. 254, the operation can be performed at maximum 255 speeds.

Always set "0" to the auxiliary function of the last point table.

To perform varying-speed operation, always set "0" to the dwell.

Setting "1" or more will enable the automatic continuous positioning operation.

The following table shows an example of setting.

Point table No.	Dwell [ms] (Note 1)	Auxiliary function	Varying-speed operation
1	0	1	Consecutive point table data
2	0	1	
3	Disabled	0 (Note 2)	
4	0	1	Consecutive point table data
5	0	1	
6	Disabled	0 (Note 2)	

Note 1. Always set "0".

Note 2. Always set "0" to the auxiliary function of the last point table among the consecutive point tables.

The following shows an operation example with the set values listed in the table below.

Point table No.	Position data [10^{STM} μm]	Servo motor speed [r/min]	Acceleration time constant [ms]	Deceleration time constant [ms]	Dwell [ms] (Note 1)	Auxiliary function	M code
1	5.00	3000	100	150	0	1	05
2	3.00	2000	Disabled	Disabled	0	1	10
3	2.00	1000	Disabled	Disabled	0	1	15
4	6.00	500	Disabled	Disabled	Disabled	0 (Note 2)	20

Note 1. Always set "0".

Note 2. Always set "0" to the auxiliary function of the last point table among the consecutive point tables.

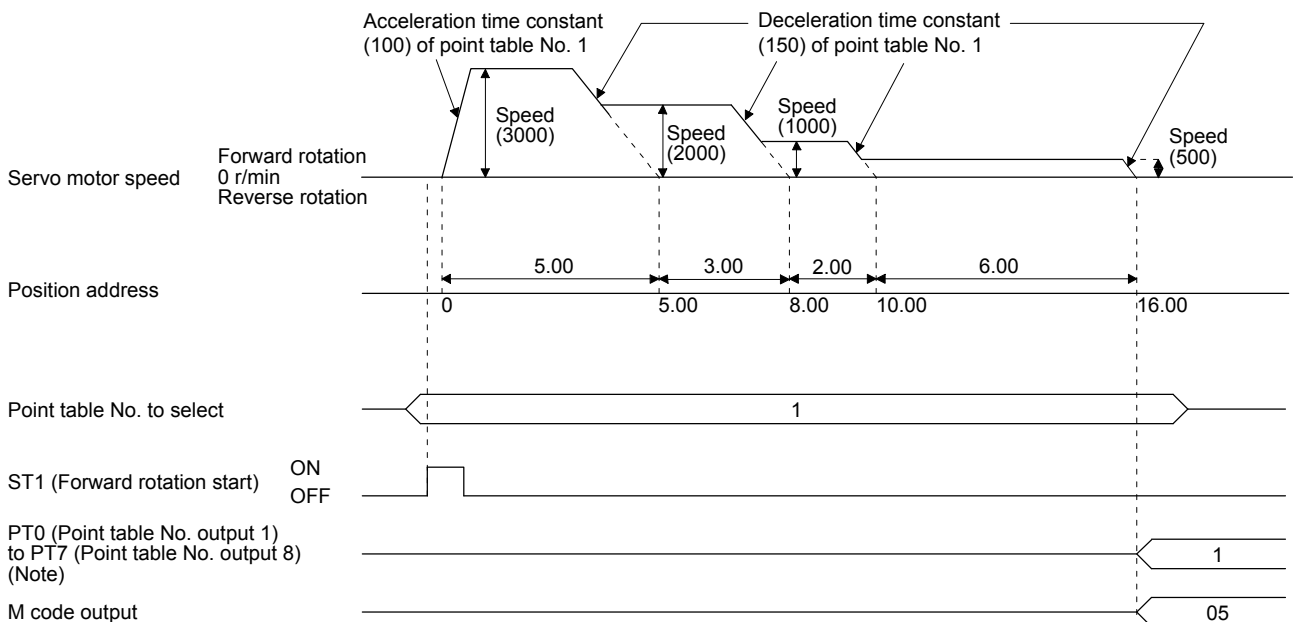

Note. For MR-J4-03A6-RJ servo amplifiers, up to six points of DO are available; therefore, PT0 to PT7 cannot be outputted simultaneously.

4. HOW TO USE THE POINT TABLE

(d) Automatic repeat positioning operation

By setting the auxiliary function of the point table, the operation pattern of the set point table No. can be returned to, and the positioning operation can be performed repeatedly.

1) Absolute value command method ([Pr. PT01] = ___ 0)

Setting "8" or "10" to the auxiliary function performs automatic continuous operation or varying-speed operation until that point table, and after the completion of positioning, performs the operation again from the operation pattern of the point table No. used at start-up.

Setting "9" or "11" to the auxiliary function performs automatic continuous operation or varying-speed operation until that point table, and after the completion of positioning, performs the operation again from the operation pattern of point table No. 1.

a) Automatic repeat positioning operation by absolute value command method

Example 1. Operations when "8" is set to the auxiliary function of point table No. 4

Point table No.	Position data [10 ⁵ μm]	Servo motor speed [r/min]	Acceleration time constant [ms]	Deceleration time constant [ms]	Dwell [ms]	Auxiliary function	M code
1	4.00	1500	200	100	150	1	01
2	5.00	3000	100	150	100	1	05
3	5.00	2000	150	200	200	3	10
4	15.00	1000	300	100	150	8	15

Operation sequence

1) Starting with point table No. 2

2) Executing point table No. 3

3) Executing point table No. 4

4) Executing again point table No. 2 used at start-up when "8" is set to the auxiliary function of point table No. 4

5) Repeating the above execution in the sequence of 2) to 3) to 4) to 2) to 3) to 4)

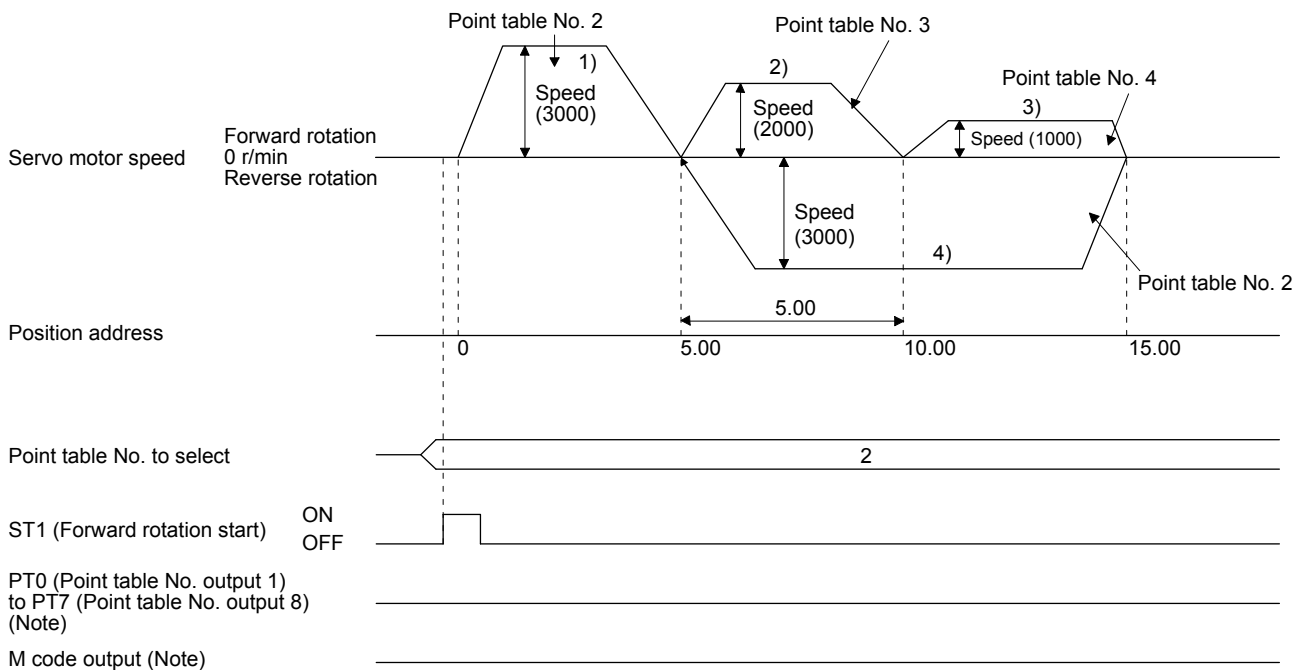

Note. PT0 to PT7 and M code are not outputted in automatic continuous operation.

4. HOW TO USE THE POINT TABLE

Example 2. Operations when "9" is set to the auxiliary function of point table No. 3

Point table No.	Position data [10 ^{STM} μm]	Servo motor speed [r/min]	Acceleration time constant [ms]	Deceleration time constant [ms]	Dwell [ms]	Auxiliary function	M code
1	0.00	3000	100	150	100	1	05
2	5.00	2000	150	200	200	1	10
3	15.00	1000	300	100	150	9	15

Operation sequence

- 1) Starting with point table No. 2
- 2) Executing point table No. 3
- 3) Executing point table No. 1 when "9" is set to the auxiliary function of point table No. 3
- 4) Repeating the above execution in the sequence of 1) to 2) to 3) to 1) to 2) to 3)

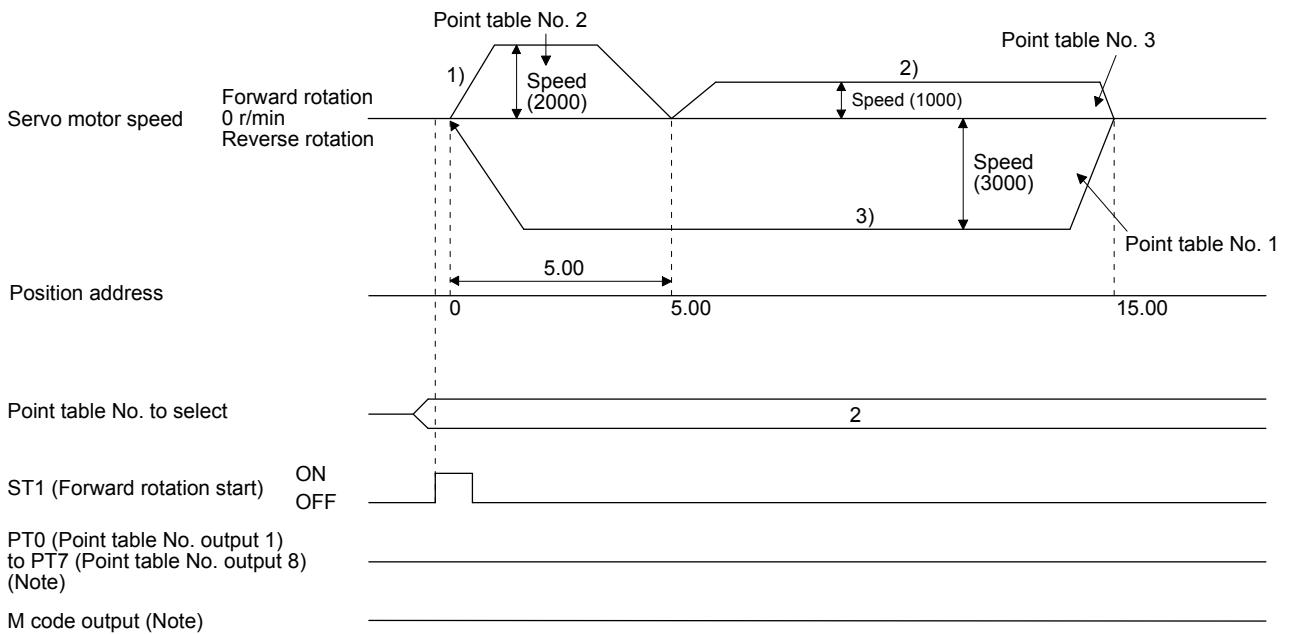

Note. PT0 to PT7 and M code are not outputted in automatic continuous operation.

4. HOW TO USE THE POINT TABLE

b) Automatic repeat positioning operation by incremental value command method

Example 1. Operations when "10" is set to the auxiliary function of point table No. 4

Point table No.	Position data [10 ^{STM} μm]	Servo motor speed [r/min]	Acceleration time constant [ms]	Deceleration time constant [ms]	Dwell [ms]	Auxiliary function	M code
1	4.00	1500	200	100	150	1	01
2	5.00	3000	100	150	100	3	05
3	10.00	2000	150	200	200	1	10
4	5.00	1000	300	100	150	10	15

Operation sequence

- 1) Starting with point table No. 2
- 2) Executing point table No. 3
- 3) Executing point table No. 4
- 4) Executing again point table No. 2 used at start-up when "10" is set to the auxiliary function of point table No. 4
- 5) Repeating the above execution in the sequence of 1) to 2) to 3) to 4) to 2) to 3) to 4)

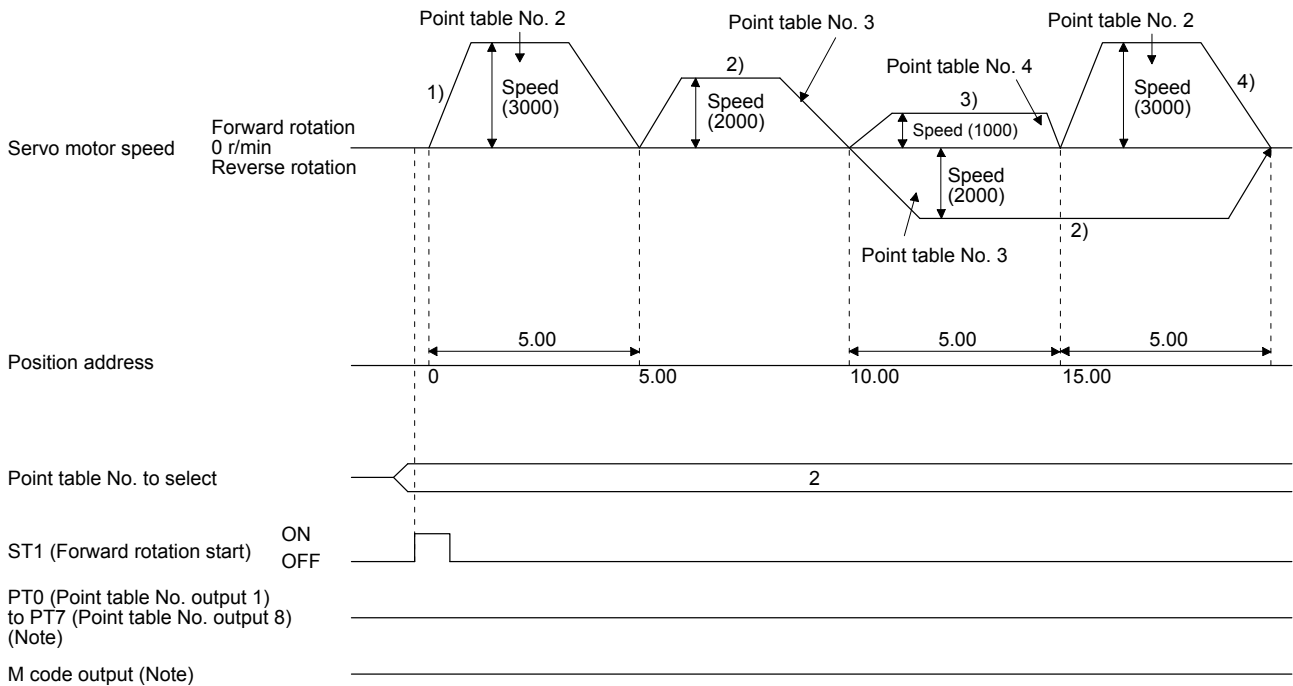

Note. PT0 to PT7 and M code are not outputted in automatic continuous operation.

4. HOW TO USE THE POINT TABLE

c) Varying-speed operation by absolute value command method

Example. Operations when "8" is set to the auxiliary function of point table No. 3

Point table No.	Position data [10 ^{STM} μm]	Servo motor speed [r/min]	Acceleration time constant [ms]	Deceleration time constant [ms]	Dwell [ms]	Auxiliary function	M code
1	5.00	3000	100	150	0	1	05
2	5.00	2000	Disabled	Disabled	0	3	10
3	15.00	1000	Disabled	Disabled	0	8	15

Operation sequence

- 1) Starting with point table No. 1
- 2) Varying the speed and executing point table No. 2
- 3) Varying the speed and executing point table No. 3
- 4) Executing point table No. 1 used at start-up in CW direction when "8" is set to the auxiliary function of point table No. 3
- 5) Repeating the above execution in the sequence of 1) to 2) to 3) to 4) to 2) to 3) to 4)

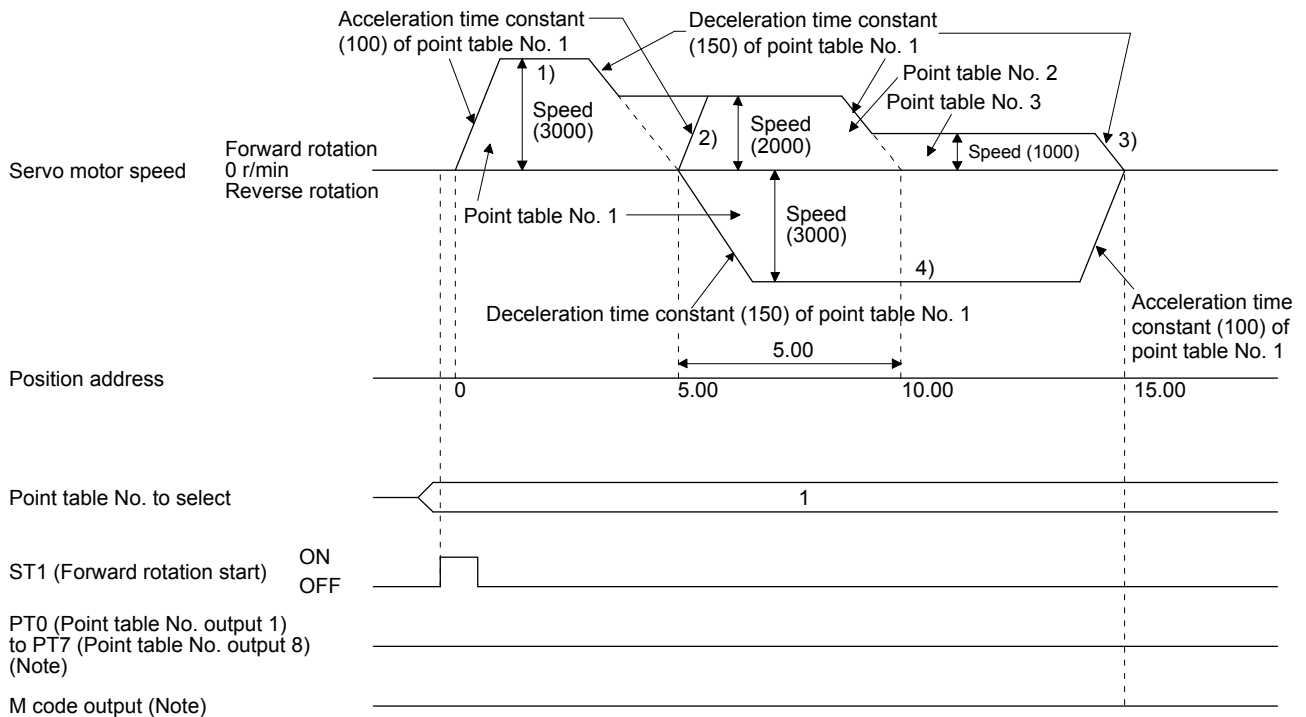

Note. PT0 to PT7 and M code are not outputted in automatic continuous operation.

4. HOW TO USE THE POINT TABLE

d) Varying-speed operation by incremental value command method

Example. Operations when "10" is set to the auxiliary function of point table No. 3

Point table No.	Position data [10 ^{STM} μm]	Servo motor speed [r/min]	Acceleration time constant [ms]	Deceleration time constant [ms]	Dwell [ms]	Auxiliary function	M code
1	5.00	3000	100	150	0	3	05
2	10.00	2000	150	200	0	1	10
3	5.00	1000	300	100	0	10	15

Operation sequence

- 1) Starting with point table No. 1
- 2) Varying the speed and executing point table No. 2
- 3) Varying the speed and executing point table No. 3
- 4) Varying the speed, and executing point table No. 1 when "10" is set to the auxiliary function of point table No. 3
- 5) Repeating the above execution in the sequence of 1) to 2) to 3) to 4) to 2) to 3) to 4)

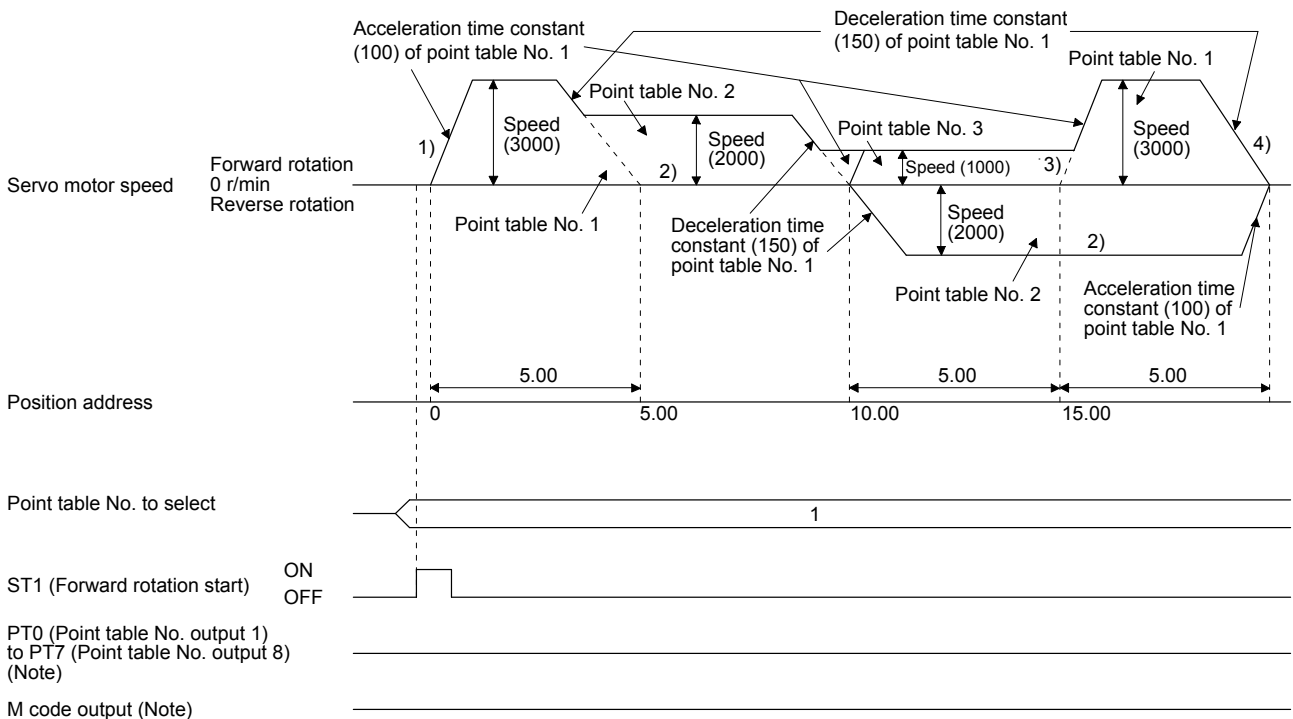

Note. PT0 to PT7 and M code are not outputted in automatic continuous operation.

4. HOW TO USE THE POINT TABLE

2) Incremental value command method ([Pr. PT01] = ___ 1)

Setting "8" to the auxiliary function performs automatic continuous operation or varying-speed operation until that point table, and after the completion of positioning, performs the operation again from the operation pattern of the set point table.

Setting "9" to the auxiliary function performs automatic continuous operation or varying-speed operation until that point table, and after the completion of positioning, performs the operation again from the operation pattern of point table No. 1.

a) Automatic repeat positioning operation by incremental value command method

Example 1. Operations when "8" is set to the auxiliary function of point table No. 3

Point table No.	Position data [10 ^{STM} μm]	Servo motor speed [r/min]	Acceleration time constant [ms]	Deceleration time constant [ms]	Dwell [ms]	Auxiliary function	M code
1	4.00	1500	200	100	150	1	01
2	5.00	3000	100	150	100	1	05
3	6.00	2000	150	200	200	8	10

Operation sequence

1) Starting with point table No. 2

2) Executing point table No. 3

3) Executing again point table No. 2 used at start-up when "8" is set to the auxiliary function of point table No. 3

4) Repeating the above execution in the sequence of 1) to 2) to 3) to 2) to 3)

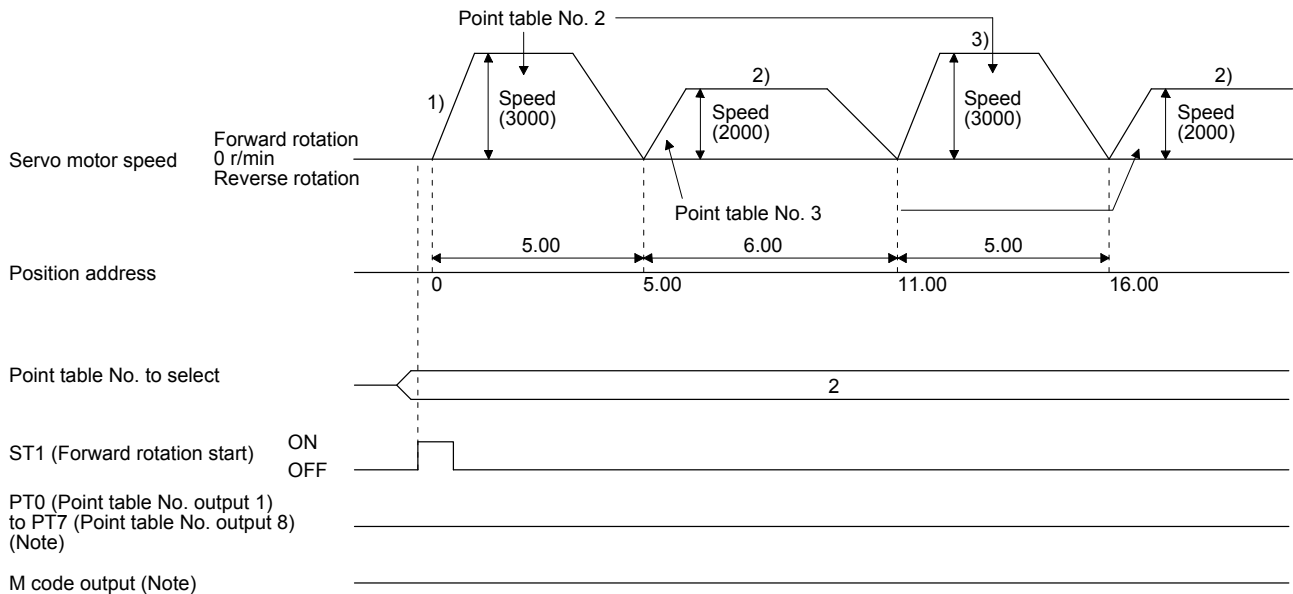

Note. PT0 to PT7 and M code are not outputted in automatic continuous operation.

4. HOW TO USE THE POINT TABLE

Example 2. Operations when "9" is set to the auxiliary function of point table No. 2

Point table No.	Position data [10 ^{STM} μm]	Servo motor speed [r/min]	Acceleration time constant [ms]	Deceleration time constant [ms]	Dwell [ms]	Auxiliary function	M code
1	5.00	3000	100	150	100	1	05
2	6.00	2000	150	200	200	9	10

Operation sequence

- 1) Starting with point table No. 2
- 2) Executing point table No. 1 when "9" is set to the auxiliary function of point table No. 2
- 3) Repeating the above execution in the sequence of 1) to 2) to 1) to 2)

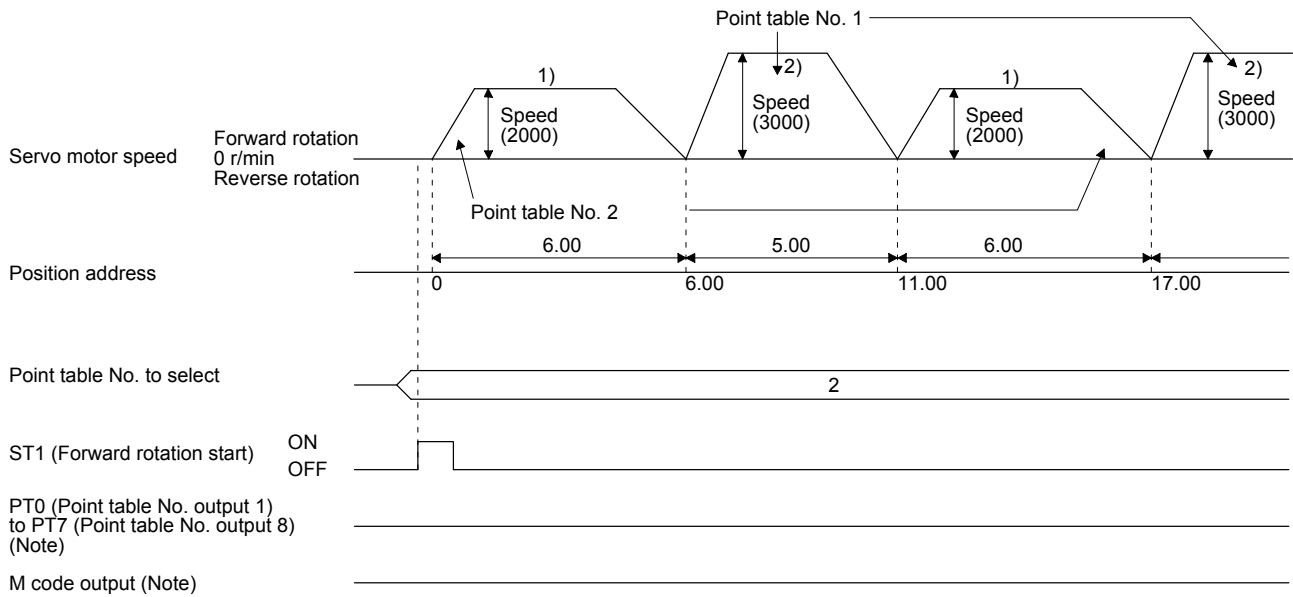

Note. PT0 to PT7 and M code are not outputted in automatic continuous operation.

4. HOW TO USE THE POINT TABLE

b) Varying-speed operation by incremental value command method

Example. Operations when "8" is set to the auxiliary function of point table No. 2

Point table No.	Position data [10 ^{STM} μm]	Servo motor speed [r/min]	Acceleration time constant [ms]	Deceleration time constant [ms]	Dwell [ms]	Auxiliary function	M code
1	5.00	3000	100	150	0	1	05
2	6.00	2000	Disabled	Disabled	0	8	10

Operation sequence

- 1) Starting with point table No. 1
- 2) Varying the speed and executing point table No. 2
- 3) Executing again point table No. 1 used at start-up when "8" is set to the auxiliary function of point table No. 2
- 4) Repeating the above execution in the sequence of 1) to 2) to 3) to 2) to 3)

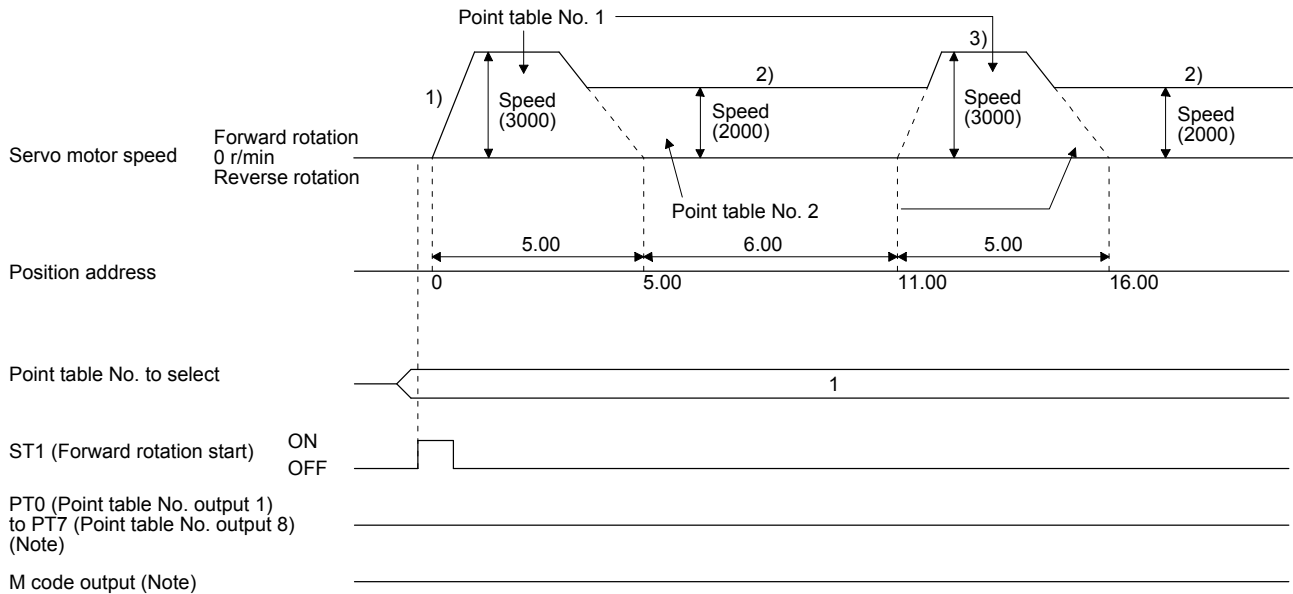

Note. PT0 to PT7 and M code are not outputted in automatic continuous operation.

4. HOW TO USE THE POINT TABLE

(e) Temporary stop/restart

When TSTP (Temporary stop/restart) is switched on during automatic operation, the servo motor decelerates with the deceleration time constant of the point table being executed, and then stops temporarily.

Switching on TSTP (Temporary stop/restart) again starts the servo motor rotation for the remaining travel distance.

During a temporary stop, ST1 (Forward rotation start) or ST2 (Reverse rotation start) does not function even if it is switched on.

When any of the following conditions is satisfied during a temporary stop, the remaining travel distance is cleared.

- The operation mode is switched from the automatic mode to the manual mode.
- The servo motor enters the servo-off status.
- The clear signal is input.

The temporary stop/restart input does not function during a home position return or JOG operation.

The temporary stop/restart input functions in the following states.

Operation status	Automatic operation	Manual operation	Home position return
During a stop			
During acceleration	Temporary stop		
At a constant speed	Temporary stop		
During deceleration			
During a temporary stop	Restart		

1) When the servo motor is rotating

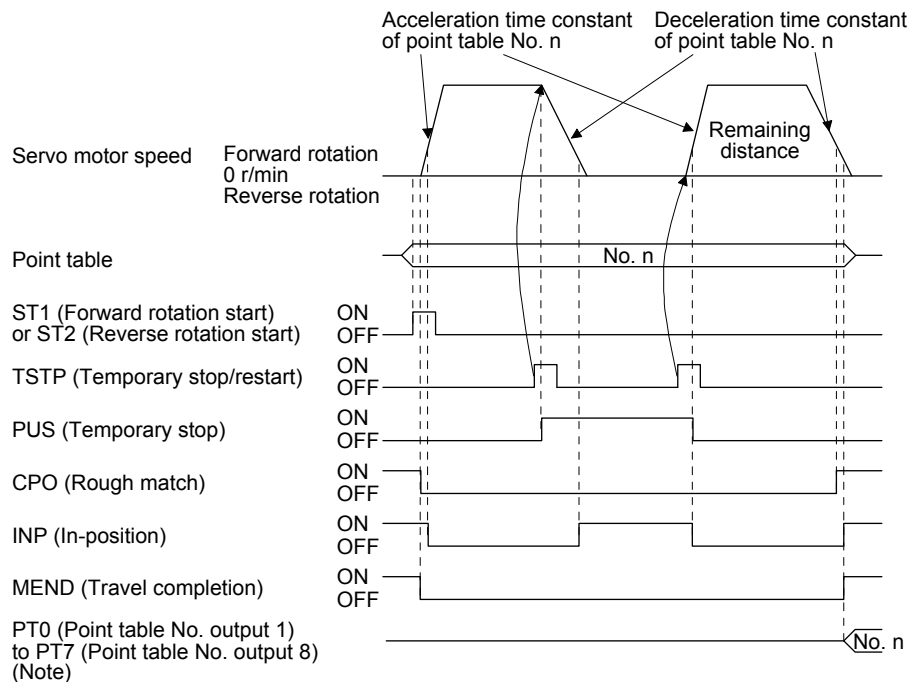

Note. For MR-J4-03A6-RJ servo amplifiers, up to six points of DO are available; therefore, PT0 to PT7 cannot be outputted simultaneously.

4. HOW TO USE THE POINT TABLE

2) During dwell

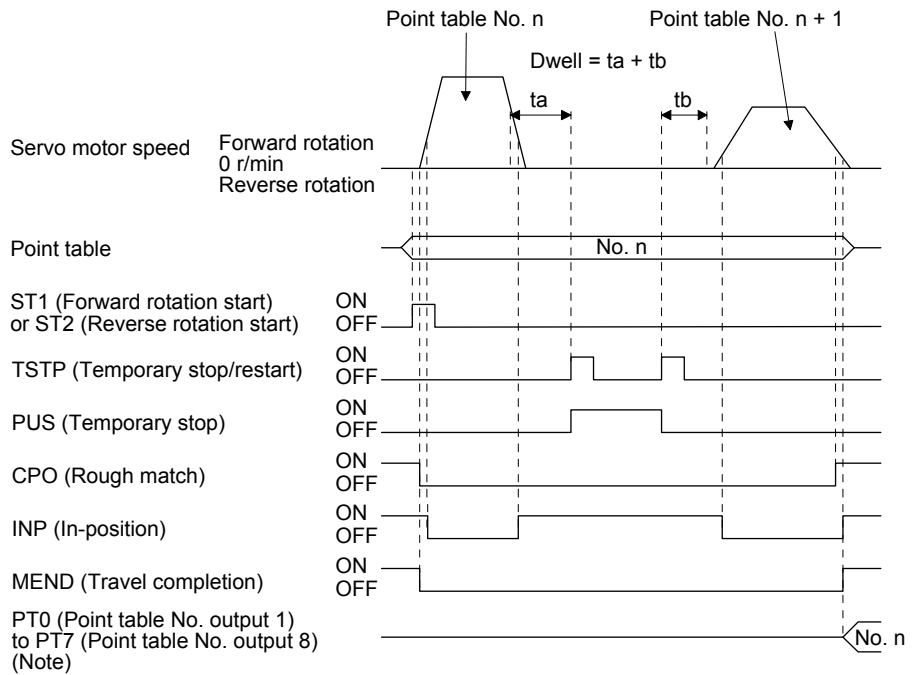

Note. For MR-J4-03A6-RJ servo amplifiers, up to six points of DO are available; therefore, PT0 to PT7 cannot be outputted simultaneously.

(f) Suspension of automatic operation

To suspend the automatic operation or change the operation pattern, stop the servo motor with TSTP (Temporary stop/restart), switch off MD0 (Operation mode selection 1), and then set the mode to the manual mode. The remaining travel distance is cleared.

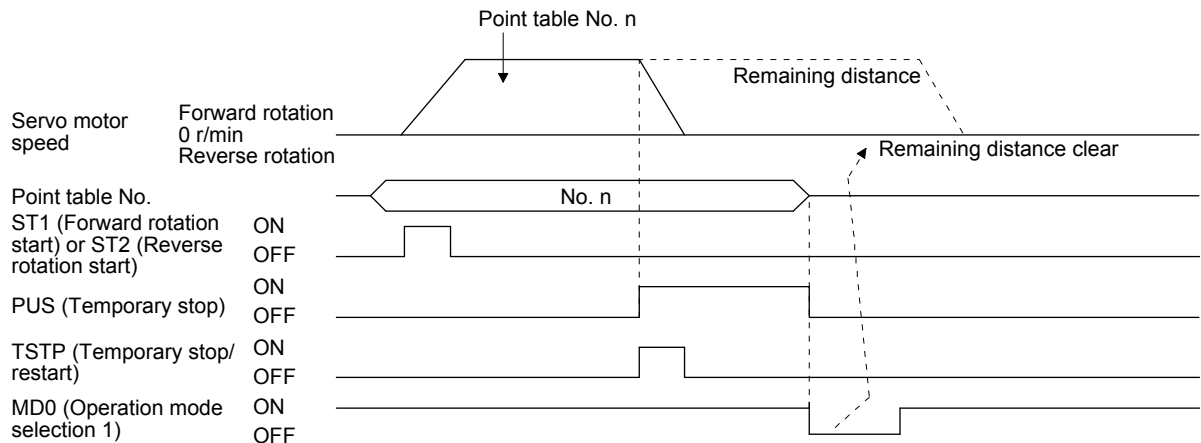

(g) Handling of control unit "degree"

1) Current position/command position address

The current position/command position address is of ring-address type.

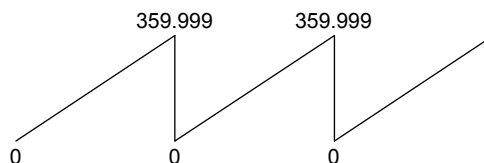

4. HOW TO USE THE POINT TABLE

2) Software limit activation/deactivation setting

POINT
<ul style="list-style-type: none"> ● After changing the "+" or "-" sign of an axis with the software limit activation setting, perform a home position return. ● When activating the software limit in an incremental system, perform a home position return after power-on.

a) Setting range

When the unit is "degree", the setting range of the software limit is 0 degree (lower limit) to 359.999 degrees (upper limit).

When you set a value other than 0 degree to 359.999 degrees in [Pr. PT15] to [Pr. PT18], the set value is converted as follows. (It will be clamped between 0 degree and 359.999 degrees.)

Software limit value	After conversion
360.000 degrees to 999.999 degrees	The remainder of the set value divided by 360
-0.001 degrees to -359.999 degrees	The sum of the set value and 360
-360.000 degrees to -999.999 degrees	The sum of 360 and the quotient of the set value divided by 360

b) When the software limit is activated

Set the software limit - ([Pr. PT17] and [Pr. PT18]) for the start position and the software limit + ([Pr. PT15] and [Pr. PT16]) for the target position.

The movable range is the section from - to + in the CCW direction.

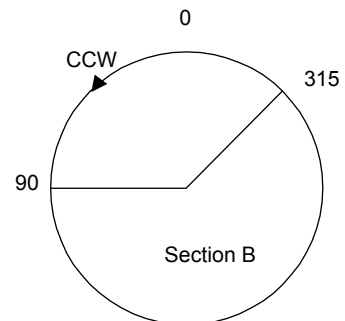
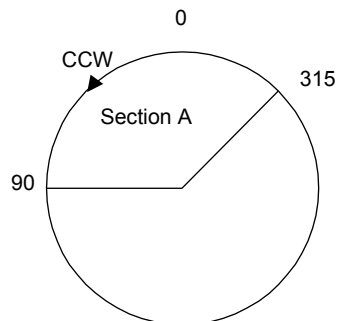

Set the movable range of section A as follows.

- Software limit - ... 315.000 degrees
- Software limit + ... 90.000 degrees

Set the movable range of section B as follows.

- Software limit - ... 90.000 degrees
- Software limit + ... 315.000 degrees

4. HOW TO USE THE POINT TABLE

c) When the software limit is deactivated

When deactivating the software limit, set the same values to the software limit - ([Pr. PT17] and [Pr. PT18]) and the software limit + ([Pr. PT15] and [Pr. PT16]).

Control can be performed independently of the software limit setting.

3) Position range output activation/deactivation setting

a) Setting range

When the unit is "degree", the setting range of the position range output is 0 degree (lower limit) to 359.999 degrees (upper limit).

When you set a value other than 0 degree to 359.999 degrees in [Pr. PT19] to [Pr. PT22], the set value is converted as follows. (It will be clamped between 0 degree and 359.999 degrees.)

Position range output address	After conversion
360.000 degrees to 999.999 degrees	The remainder of the set value divided by 360
-0.001 degrees to -359.999 degrees	The sum of the set value and 360
-360.000 degrees to -999.999 degrees	The sum of 360 and the quotient of the set value divided by 360

b) Effective setting of position range output

Set the position range output address - ([Pr. PT21] and [Pr. PT22]) for the start position and the position range output address + ([Pr. PT19] and [Pr. PT20]) for the target position.

The movable range is the section from - to + in the CCW direction.

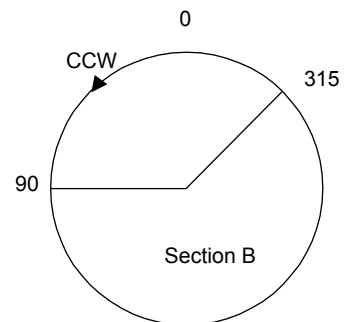
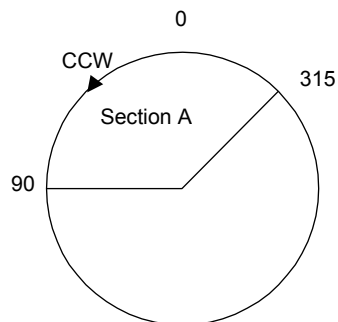

Set the movable range of section A as follows.

- Position range output address - ... 315.000 degrees
- Position range output address + ... 90.000 degrees

Set the movable range of section B as follows.

- Position range output address - ... 90.000 degrees
- Position range output address + ... 315.000 degrees

4. HOW TO USE THE POINT TABLE

4.3 Manual operation mode

For the machine adjustment, matching of home position, or the like, the JOG operation or the manual pulse generator operation can be used for movement to an arbitrary position.

4.3.1 JOG operation

(1) Setting

According to the purpose of use, set input devices and parameters as shown below. In this case, DI0 (Point table No. selection 1) to DI7 (Point table No. selection 8) are invalid.

Item	Used device/parameter	Setting
Manual operation mode selection	MD0 (Operation mode selection 1)	Switch off MD0.
Servo motor rotation direction	[Pr. PA14]	Refer to (2) of this section.
JOG speed	[Pr. PT13]	Set the servo motor speed.
Acceleration/deceleration time constant	Point table No. 1	Use the acceleration/deceleration time constant of point table No. 1.

(2) Servo motor rotation direction

[Pr. PA14] setting	Servo motor rotation direction	
	ST1 (Forward rotation start) on	ST2 (Reverse rotation start) on
0	CCW rotation	CW rotation
1	CW rotation	CCW rotation

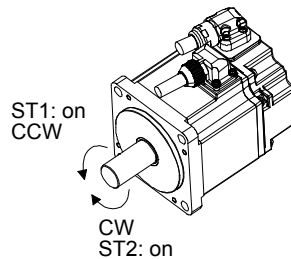

[Pr. PA14]: 0

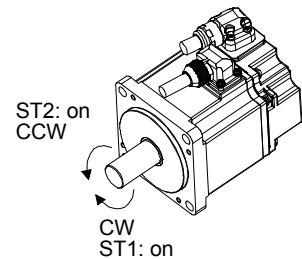

[Pr. PA14]: 1

(3) Operation

Switching on ST1 (Forward rotation start) performs the operation at the JOG speed set by a parameter and the acceleration/deceleration constant of point table No. 1. For the rotation direction, refer to (2) of this section. Switching on ST2 (Reverse rotation start) starts the rotation in the reverse direction of ST1 (Forward rotation start).

Simultaneously switching on or off ST1 (Forward rotation start) and ST2 (Reverse rotation start) stops the operation.

4. HOW TO USE THE POINT TABLE

(4) Timing chart

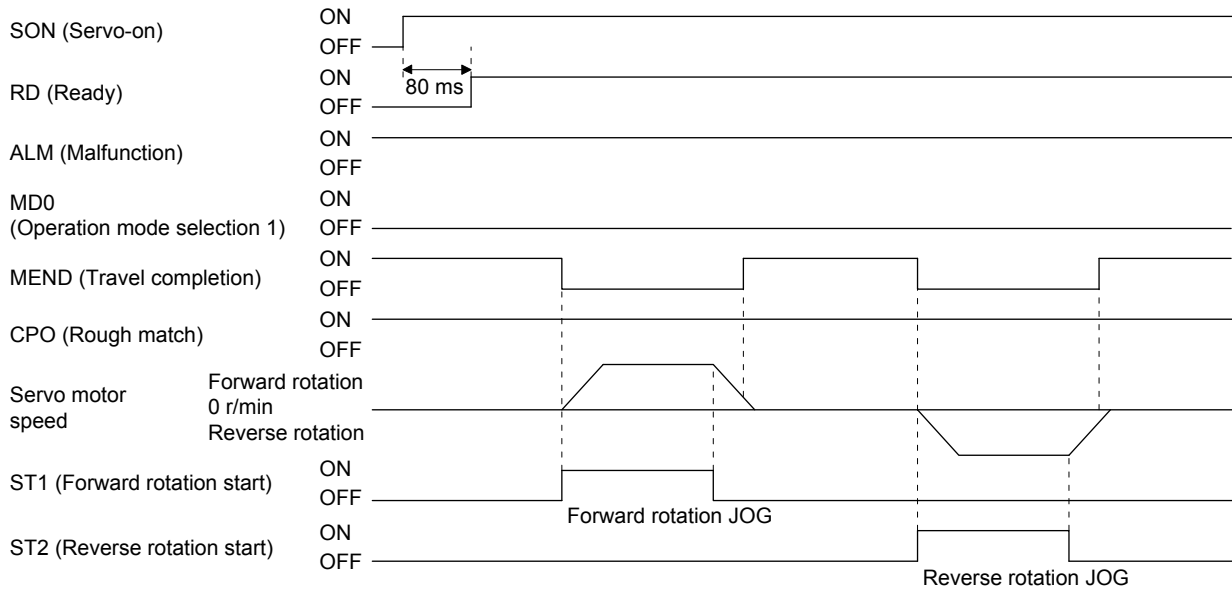

4. HOW TO USE THE POINT TABLE

4.3.2 Manual pulse generator operation

(1) Setting

POINT
<p>● To enhance noise tolerance, set "_ 2 _" to [Pr. PA13] when the command pulse frequency is 500 kpulses/s or less, or set "_ 3 _" to [Pr. PA13] when the command pulse frequency is 200 kpulses/s or less.</p>

According to the purpose of use, set input devices and parameters as shown below. In this case, DI0 (Point table No. selection 1) to DI7 (Point table No. selection 8) are invalid.

Item	Device/parameter to be used	Setting
Manual operation mode selection	MD0 (Operation mode selection 1)	Switch off MD0.
Manual pulse generator multiplication	[Pr. PT03]	Set the multiplication factor for the pulses generated from the manual pulse generator. For details, refer to (3) of this section.
Servo motor rotation direction	[Pr. PA14]	Refer to (2) of this section.
Command input pulse train input form	[Pr. PA13]	Set "_ _ _ 2" (A/B-phase pulse train).
Pulse train filter selection	[Pr. PA13]	Set other than "_ 0 _" and "_ 1 _".

(2) Servo motor rotation direction

[Pr. PA14] setting	Servo motor rotation direction	
	Manual pulse generator operation: forward rotation	Manual pulse generator operation: reverse rotation
0	CCW rotation	CW rotation
1	CW rotation	CCW rotation

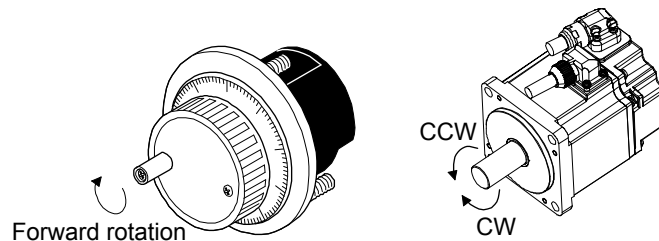

4. HOW TO USE THE POINT TABLE

(3) Manual pulse generator multiplication

(a) Using the input signals (devices) for setting

In "Device setting" of MR Configurator2, set TP0 (Pulse generator multiplication 1) and TP1 (Pulse generator multiplication 2) to input signals.

TP1 (Pulse generator multiplication 2) (Note)	TP0 (Pulse generator multiplication 1) (Note)	Servo motor rotation multiplication to manual pulse generator rotation amount	Travel distance			
			[mm]	[inch]	[degree]	[pulse]
0	0	[Pr. PT03] setting valid				
0	1	1 time	0.001	0.0001	0.001	1
1	0	10 times	0.01	0.001	0.01	10
1	1	100 times	0.1	0.01	0.1	100

Note. 0: Off

1: On

(b) Using the parameter for setting

Use [Pr. PT03] to set the servo motor rotation multiplication to the rotation amount of the manual pulse generator.

[Pr. PT03] setting	Servo motor rotation multiplication to manual pulse generator rotation amount	Travel distance			
		[mm]	[inch]	[degree]	[pulse]
__ 0 __	1 time	0.001	0.0001	0.001	1
__ 1 __	10 times	0.01	0.001	0.01	10
__ 2 __	100 times	0.1	0.01	0.1	100

(4) Operation

Turning the manual pulse generator starts the servo motor rotation. For the rotation direction of the servo motor, refer to (2) of this section. When you turn the manual pulse generator during a JOG operation, the commands inputted from the manual pulse generator are adjusted by the commands of JOG operation.

4. HOW TO USE THE POINT TABLE

4.4 Home position return mode

Point
<ul style="list-style-type: none">● Before performing the home position return, make sure that the limit switch operates.● Check the home position return direction. An incorrect setting will cause a reverse running.● Check the input polarity of the proximity dog. Otherwise, it may cause an unexpected operation.● In the following cases, make sure that the Z-phase has been passed through once before performing a home position return.<ul style="list-style-type: none">▪ When an incremental linear encoder is used in the linear servo motor control mode▪ When an incremental external encoder is used in the fully closed loop control mode▪ When a servo amplifier is used in the DD motor control modeZ-phase unpassed will trigger [AL. 90.5 Home position return incomplete warning].● For servo amplifiers with software version B6 or earlier, the dog type last Z-phase reference home position return and the dogless Z-phase reference home position return cannot be used in the following operation modes.<ul style="list-style-type: none">▪ Fully closed loop control mode using an incremental linear encoder▪ Linear servo motor control mode using an incremental linear encoder▪ Direct drive motor control modeSetting [Pr. PT04 Home position return type] to "___ 8" or "___ A" will trigger [AL. 37 Parameter error].● For precautions for using linear servo motors or fully closed loop system, refer to section 4.4.15 and 4.4.16.

4.4.1 Outline of home position return

A home position return is performed to match the command coordinates with the machine coordinates. Under the incremental method, every time switching on the input power supply, you have to perform the home position return. Contrastingly, in the absolute position detection system, once you have performed the home position return at machine installation, the current position will be retained even if the power supply is shut off. Thereafter, the home position return is unnecessary when the power supply is switched on. This section shows the home position return methods of the servo amplifier. Select the optimum method according to the configuration and uses of the machine.

This servo amplifier has a home position return automatic retract function. When the machine stops on or beyond the proximity dog, this function automatically backs the machine to the proper position and then performs the home position return. Manually moving the machine by the JOG operation or others is unnecessary.

4. HOW TO USE THE POINT TABLE

(1) Home position return types

Select the optimum home position return type according to the machine type or others.

Type	Home position return method	Feature
Dog type	Deceleration starts at the proximity dog front end. After the rear end is passed, the position specified by the first Z-phase signal, or the position of the first Z-phase signal shifted by the home position shift distance is used as the home position.	<ul style="list-style-type: none"> • General home position return method using a proximity dog • The repeatability of the home position return is high. • The machine is less loaded. • Used when the width of the proximity dog can be set equal to or greater than the deceleration distance of the servo motor.
Count type	Deceleration starts at the proximity dog front end. After the proximity dog is passed, the motor travels the specified travel distance. Then, the position specified by the first Z-phase signal, or the position of the first Z-phase signal shifted by the home position shift distance is used as the home position.	<ul style="list-style-type: none"> • Home position return method using a proximity dog • Used to minimize the length of the proximity dog.
Data set type	An arbitrary position is used as the home position.	<ul style="list-style-type: none"> • No proximity dog is required.
Stopper type	A workpiece is pressed against a mechanical stopper, and the position where it is stopped is set as the home position.	<ul style="list-style-type: none"> • The home position return speed must be low enough because of the collision with the mechanical stopper. • The strength of the machine and its stopper must be increased.
Home position ignorance (servo-on position as home position)	The position where the servo is switched on is used as the home position.	
Dog type rear end reference	Deceleration starts at the proximity dog front end. After the rear end is passed, the position is shifted by the travel distance after proximity dog and the home position shift distance. The position after the shifts is set as the home position.	<ul style="list-style-type: none"> • The Z-phase signal is not required.
Count type front end reference	Deceleration starts at the proximity dog front end. The position is shifted by the travel distance after proximity dog and the home position shift distance. The position after the shifts is set as the home position.	<ul style="list-style-type: none"> • The Z-phase signal is not required.
Dog cradle type	After the proximity dog front end is detected, the position specified by the first Z-phase signal is used as the home position.	
Dog type last Z-phase reference	After the proximity dog front end is detected, the position is shifted away from the proximity dog in the reverse direction. Then, the position specified by the first Z-phase signal, or the position of the first Z-phase signal shifted by the home position shift distance is used as the home position.	
Dog type front end reference	From the proximity dog front end, the position is shifted by the travel distance after proximity dog and the home position shift distance. The position after the shifts is set as the home position.	<ul style="list-style-type: none"> • The Z-phase signal is not required.
Dogless Z-phase reference	The position specified by the first Z-phase signal, or the position of the first Z-phase signal shifted by the home position shift distance is used as the home position.	

4. HOW TO USE THE POINT TABLE

(2) Parameters for home position return

To perform the home position return, set each parameter as follows.

(a) Select the home position return type with [Pr. PT04 Home position return type].

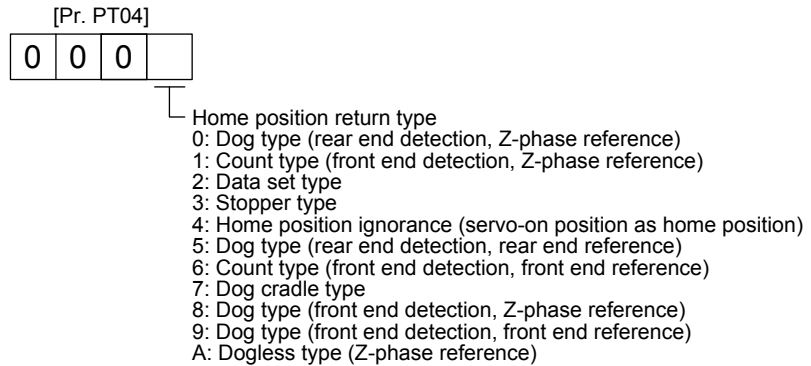

(b) Select the starting direction for the home position return with [Pr. PT04 Home position return type].

Setting "0" starts the home position return in the address increase direction from the current position.

Setting "1" starts the home position return in the address decrease direction from the current position.

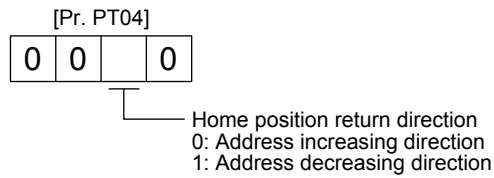

(c) Select the polarity where the proximity dog is detected with the DOG (Proximity dog) polarity selection of [Pr. PT29 Function selection T-3]. Setting "0" detects the dog when DOG (Proximity dog) is off. Setting "1" detects the dog when DOG (Proximity dog) is on.

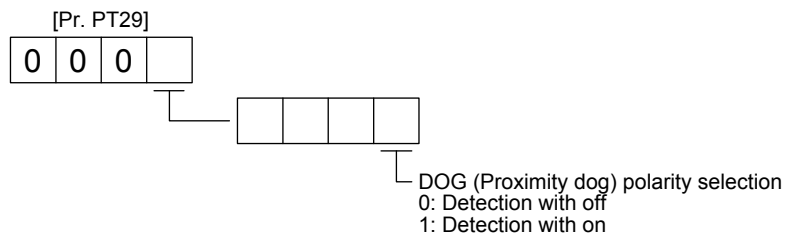

4. HOW TO USE THE POINT TABLE

4.4.2 Dog type home position return

This home position return type uses a proximity dog. Deceleration starts at the proximity dog front end. After the rear end is passed, the position specified by the first Z-phase signal, or the position of the first Z-phase signal shifted by the specified home position shift distance is used as the home position.

(1) Device/parameter

Set input devices and parameters as follows.

Item	Used device/parameter	Setting
Home position return mode selection	MD0 (Operation mode selection 1)	Switch on MD0.
	DI0 (Point table No. selection 1) to DI7 (Point table No. selection 8)	Switch off DI0 to DI7.
Dog type home position return	[Pr. PT04]	___ 0: Select the dog type.
Home position return direction	[Pr. PT04]	Refer to section 4.4.1 (2) to select the home position return direction.
Dog input polarity	[Pr. PT29]	Refer to section 4.4.1 (2) to select the proximity dog input polarity.
Home position return speed	[Pr. PT05]	Set the rotation speed until the dog is detected.
Creep speed	[Pr. PT06]	Set the rotation speed after the dog is detected.
Home position shift distance	[Pr. PT07]	Set this item to shift the home position specified by the first Z-phase signal after passage of proximity dog rear end.
Home position return acceleration/deceleration time constant	Point table No. 1	Use the acceleration/deceleration time constant of point table No. 1.
Home position return position data	[Pr. PT08]	Set the current position at the home position return completion.

(2) Proximity dog length

To generate the Z-phase signal of the servo motor during the DOG (Proximity dog) detection, the proximity dog length should satisfy formulas (4.1) and (4.2).

$$L_1 \geq \frac{V}{60} \cdot \frac{td}{2} \dots\dots\dots (4.1)$$

L_1 : Proximity dog length [mm]

V: Home position return speed [mm/min]

td: Deceleration time [s]

$$L_2 \geq 2 \cdot \Delta S \dots\dots\dots (4.2)$$

L_2 : Proximity dog length [mm]

ΔS : Travel distance per servo motor revolution [mm] (Note)

Note. For linear servo motor: travel distance per stop interval selection at the home position return of [Pr. PL01]

4. HOW TO USE THE POINT TABLE

(3) Timing chart

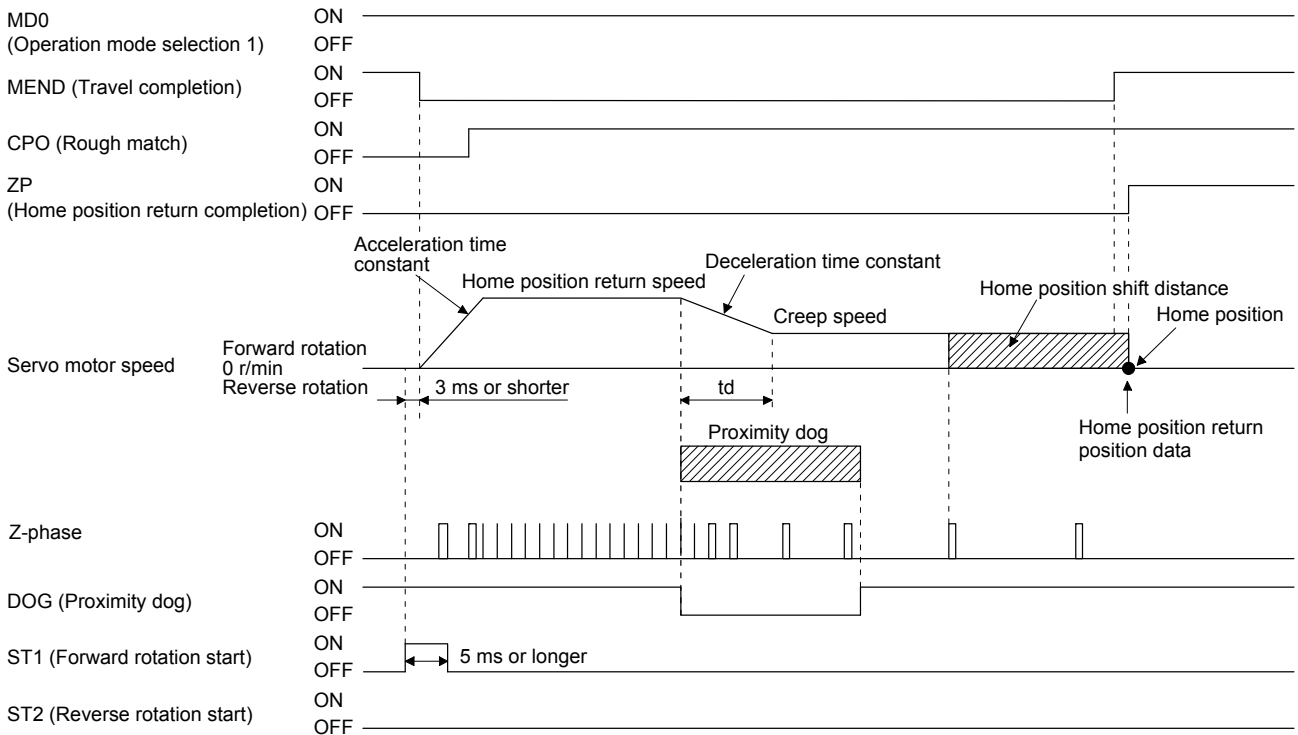

The setting value of [Pr. PT08 Home position return position data] is used as the position address at the home position return completion.

(4) Adjustment

For the dog type home position return, adjust the setting to ensure the Z-phase signal generation during the dog detection. Locate the DOG (Proximity dog) rear end almost at the center between the generation positions of two consecutive Z-phase signals.

The generation position of the Z-phase signal can be checked with "Position within one-revolution" of "Status Display" on MR Configurator2.

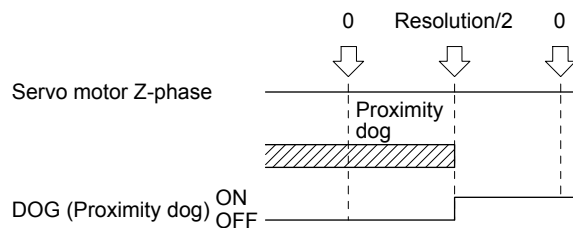

4. HOW TO USE THE POINT TABLE

4.4.3 Count type home position return

In the count type home position return, after the proximity dog front end is detected, the motor travels the distance set with [Pr. PT09 Travel distance after proximity dog]. Then, the position specified by the first Z-phase signal is used as the home position. Therefore, when DOG (Proximity dog) is on for 10 ms or longer, the proximity dog length has no restrictions. When the required proximity dog length for using the dog type home position return cannot be reserved, or when DOG (Proximity dog) is entered electrically from the controller or the like, use the count type home position return.

(1) Device/parameter

Set input devices and parameters as follows.

Item	Used device/parameter	Setting
Home position return mode selection	MD0 (Operation mode selection 1)	Switch on MD0.
	DI0 (Point table No. selection 1) to DI7 (Point table No. selection 8)	Switch off DI0 to DI7.
Count type home position return	[Pr. PT04]	___ 0: Select the count type.
Home position return direction	[Pr. PT04]	Refer to section 4.4.1 (2) to select the home position return direction.
Dog input polarity	[Pr. PT29]	Refer to section 4.4.1 (2) to select the dog input polarity.
Home position return speed	[Pr. PT05]	Set the rotation speed until the dog is detected.
Creep speed	[Pr. PT06]	Set the rotation speed after the dog is detected.
Home position shift distance	[Pr. PT07]	Set this item to shift the home position starting at the first Z-phase signal after passage of proximity dog front end and motion over the specified travel distance.
Travel distance after proximity dog	[Pr. PT09]	Set the travel distance after passage of proximity dog front end.
Home position return acceleration/deceleration time constant	Point table No. 1	Use the acceleration/deceleration time constant of point table No. 1.
Home position return position data	[Pr. PT08]	Set the current position at the home position return completion.

4. HOW TO USE THE POINT TABLE

(2) Timing chart

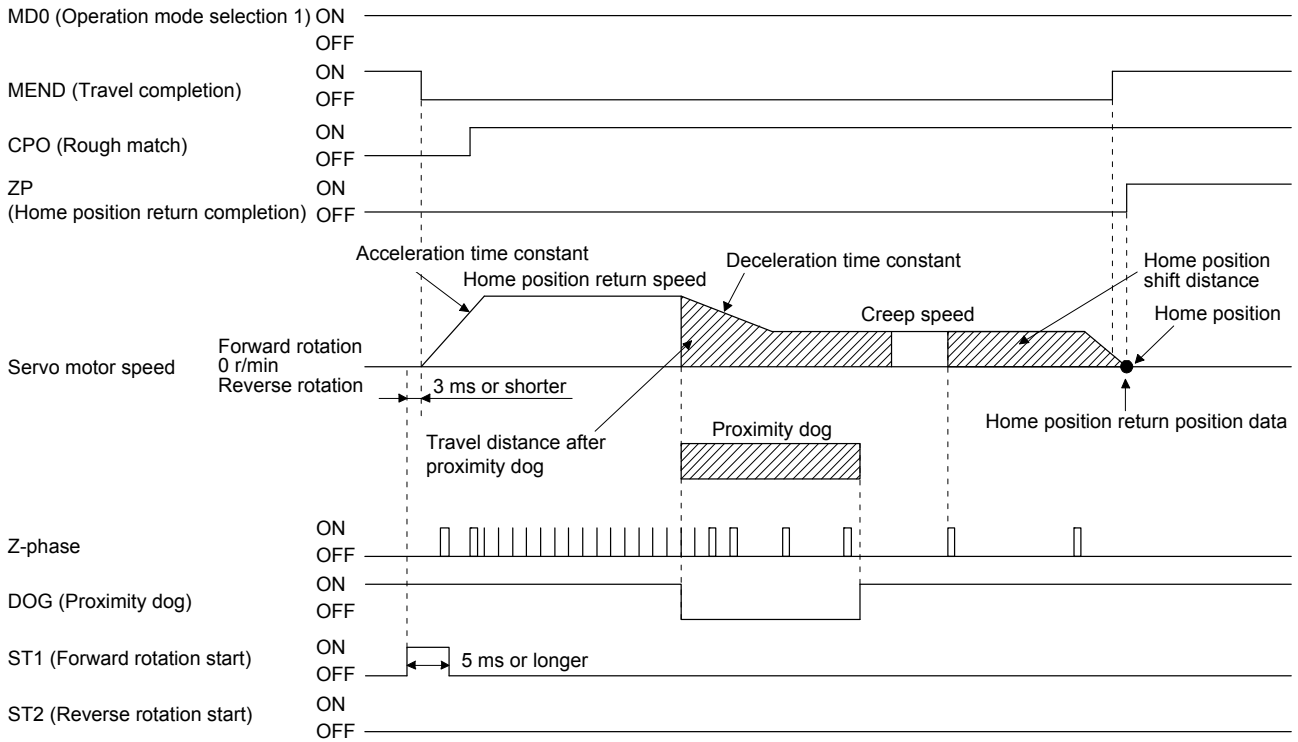

The setting value of [Pr. PT08 Home position return position data] is used as the position address at the home position return completion.

4. HOW TO USE THE POINT TABLE

4.4.4 Data set type home position return

To set an arbitrary position as the home position, use the data set type home position return. The JOG operation, manual pulse generator operation, or the like can be used for movement. You can perform the data set type home position return at servo-on only.

(1) Device/parameter

Set input devices and parameters as follows.

Item	Used device/parameter	Setting
Home position return mode selection	MD0 (Operation mode selection 1)	Switch on MD0.
	DI0 (Point table No. selection 1) to DI7 (Point table No. selection 8)	Switch off DI0 to DI7.
Data set type home position return	[Pr. PT04]	___ 2: Select the data set type.
Home position return position data	[Pr. PT08]	Set the current position at the home position return completion.

(2) Timing chart

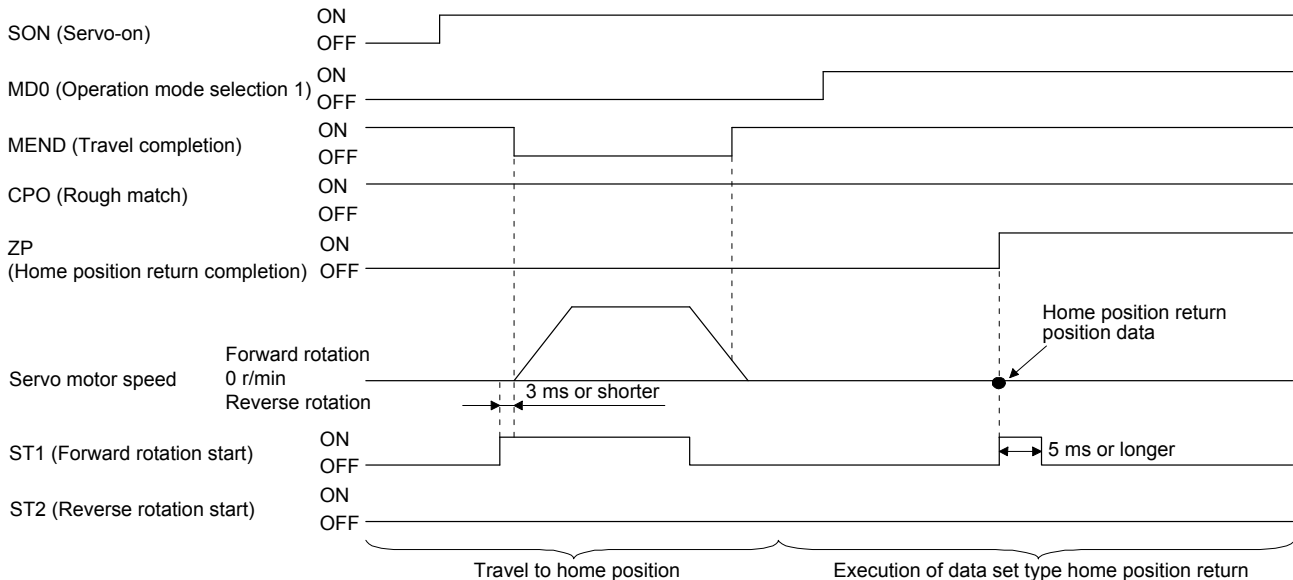

The setting value of [Pr. PT08 Home position return position data] is used as the position address at the home position return completion.

4. HOW TO USE THE POINT TABLE

4.4.5 Stopper type home position return

For the stopper type home position return, by using the JOG operation, manual pulse generator operation, or others, a workpiece is pressed against a mechanical stopper, and the position where it is stopped is used as the home position.

(1) Device/parameter

Set input devices and parameters as follows.

Item	Used device/parameter	Setting
Home position return mode selection	MD0 (Operation mode selection 1)	Switch on MD0.
	DI0 (Point table No. selection 1) to DI7 (Point table No. selection 8)	Switch off DI0 to DI7.
Stopper type home position return	[Pr. PT04]	___ 3: Select the stopper type.
Home position return direction	[Pr. PT04]	Refer to section 4.4.1 (2) to select the home position return direction.
Home position return speed	[Pr. PT05]	Set the rotation speed until the workpiece is pressed against the mechanical stopper.
Stopper time	[Pr. PT10]	Set the time from when the home position data is obtained after the workpiece is pressed against the mechanical stopper until when ZP (home position return completion) is output.
Stopper type home position return torque limit value	[Pr. PT11]	Set the servo motor torque limit value at the execution of the stopper type home position return.
Home position return acceleration time constant	Point table No. 1	The acceleration/deceleration time constant of point table No. 1 is used.
Home position return position data	[Pr. PT08]	Set the current position at the home position return completion.

4. HOW TO USE THE POINT TABLE

(2) Timing chart

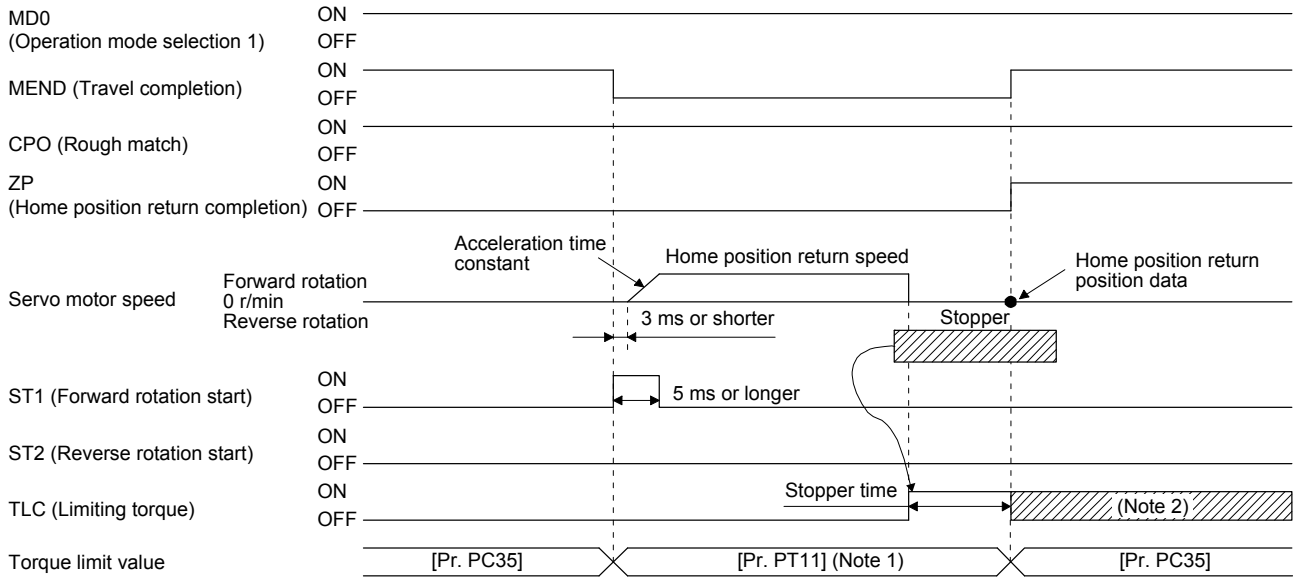

Note 1. The following torque limits are enabled.

Input device (0: Off, 1: On)		Limit value status		Enabled torque limit value
TL1	TL			
0	0			Pr. PT11
0	1	TLA	> Pr. PT11	Pr. PT11
		TLA	< Pr. PT11	TLA
1	0	Pr. PC35	> Pr. PT11	Pr. PT11
		Pr. PC35	< Pr. PT11	Pr. PC35
1	1	TLA	> Pr. PT11	Pr. PT11
		TLA	< Pr. PT11	TLA

2. TLC turns on when a generated torque reaches a value set with any of [Pr. PA11 Forward rotation torque limit], [Pr. PA12 Reverse rotation torque limit], or [Pr. PC35 Internal torque limit 2].

The setting value of [Pr. PT08 Home position return position data] is used as the position address at the home position return completion.

4. HOW TO USE THE POINT TABLE

4.4.6 Home position ignorance (servo-on position as home position)

POINT
● When you perform this home position return, it is unnecessary to switch to the home position return mode.

The position at servo-on is used as the home position.

(1) Device/parameter

Set input devices and parameters as follows.

Item	Used parameter	Setting
Home position ignorance	[Pr. PT04]	___ 4: Select the home position ignorance.
Home position return position data	[Pr. PT08]	Set the current position at the home position return completion.

(2) Timing chart

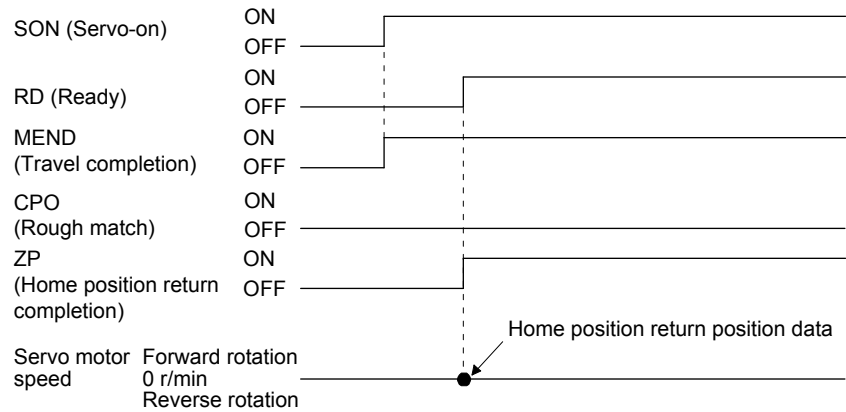

The setting value of [Pr. PT08 Home position return position data] is used as the position address at the home position return completion.

4. HOW TO USE THE POINT TABLE

4.4.7 Dog type rear end reference home position return

POINT
<p>● This home position return method depends on the timing of reading DOG (Proximity dog) that has detected the rear end of a proximity dog. Therefore, when a home position return is performed at a creep speed of 100 r/min, the home position has an error of 6400 pulses (for HG series servo motor). The higher the creep speed, the greater the error of the home position.</p>

Deceleration starts at the front end of a proximity dog. After the rear end is passed, the position is shifted by the travel distance after proximity dog and the home position shift distance. The position after the shifts is used as the home position. The home position return is available independently of the Z-phase signal. Changing the creep speed may change the home position.

(1) Device/parameter

Set input devices and parameters as follows.

Item	Used device/parameter	Setting
Home position return mode selection	MD0 (Operation mode selection 1)	Switch on MD0.
	DI0 (Point table No. selection 1) to DI7 (Point table No. selection 8)	Switch off DI0 to DI7.
Dog type rear end reference home position return	[Pr. PT04]	___ 5: Select the dog type (rear end detection/rear end reference).
Home position return direction	[Pr. PT04]	Refer to section 4.4.1 (2) to select the home position return direction.
Dog input polarity	[Pr. PT29]	Refer to section 4.4.1 (2) to select the dog input polarity.
Home position return speed	[Pr. PT05]	Set the rotation speed until the dog is detected.
Creep speed	[Pr. PT06]	Set the rotation speed after the dog is detected.
Home position shift distance	[Pr. PT07]	Set this item to shift the home position, which is specified after the rear end of a proximity dog is passed.
Travel distance after proximity dog	[Pr. PT09]	Set the travel distance specified after the rear end of a proximity dog is passed.
Home position return acceleration/deceleration time constant	Point table No. 1	Use the acceleration/deceleration time constant of point table No. 1.
Home position return position data	[Pr. PT08]	Set the current position at the home position return completion.

4. HOW TO USE THE POINT TABLE

(2) Timing chart

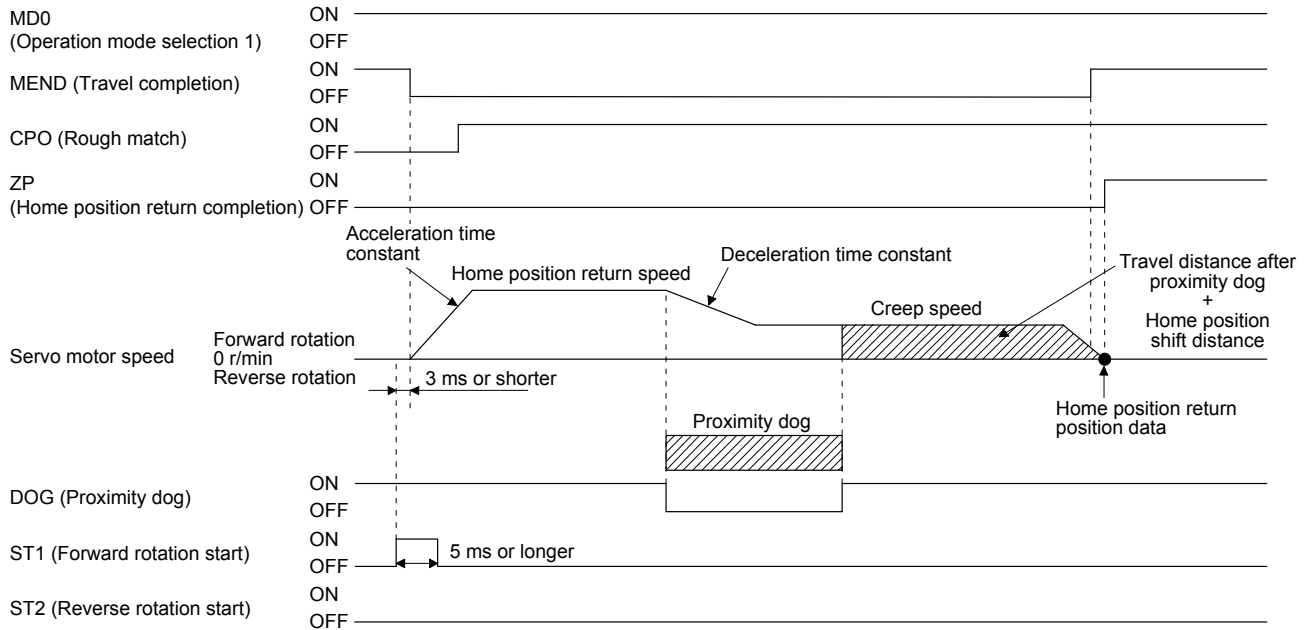

The setting value of [Pr. PT08 Home position return position data] is used as the position address at the home position return completion.

4. HOW TO USE THE POINT TABLE

4.4.8 Count type front end reference home position return

POINT
<ul style="list-style-type: none"> ● This home position return method depends on the timing of reading DOG (Proximity dog) that has detected the front end of a proximity dog. Therefore, when a home position return is performed with the creep speed of 100 r/min, the home position has an error of 6400 pulses (for HG series servo motor). The higher the creep speed, the greater the error of the home position. ● After the front end of a proximity dog is detected, when a home position return ends without reaching the creep speed, [AL. 90] occurs. Set the travel distance after proximity dog and the home position shift distance enough for deceleration from the home position return speed to the creep speed.

Deceleration starts at the front end of a proximity dog. The position is shifted by the travel distance after proximity dog and the home position shift distance. The position after the shifts is used as the home position. The home position return is available independently of the Z-phase signal. Changing the creep speed may change the home position.

(1) Device/parameter

Set input devices and parameters as follows.

Item	Used device/parameter	Setting
Home position return mode selection	MD0 (Operation mode selection 1)	Switch on MD0.
	DI0 (Point table No. selection 1) to DI7 (Point table No. selection 8)	Switch off DI0 to DI7.
Count type front end reference home position return	[Pr. PT04]	___6: Select the count type (front end detection/front end reference).
Home position return direction	[Pr. PT04]	Refer to section 4.4.1 (2) to select the home position return direction.
Dog input polarity	[Pr. PT29]	Refer to section 4.4.1 (2) to select the dog input polarity.
Home position return speed	[Pr. PT05]	Set the rotation speed until the dog is detected.
Creep speed	[Pr. PT06]	Set the rotation speed after the dog is detected.
Home position shift distance	[Pr. PT07]	Set this to shift the home position, which is specified after the front end of a proximity dog is passed.
Travel distance after proximity dog	[Pr. PT09]	Set the travel distance specified after the front end of the proximity dog is passed.
Home position return acceleration/deceleration time constant	Point table No. 1	Use the acceleration/deceleration time constant of point table No. 1.
Home position return position data	[Pr. PT08]	Set the current position at the home position return completion.

4. HOW TO USE THE POINT TABLE

(2) Timing chart

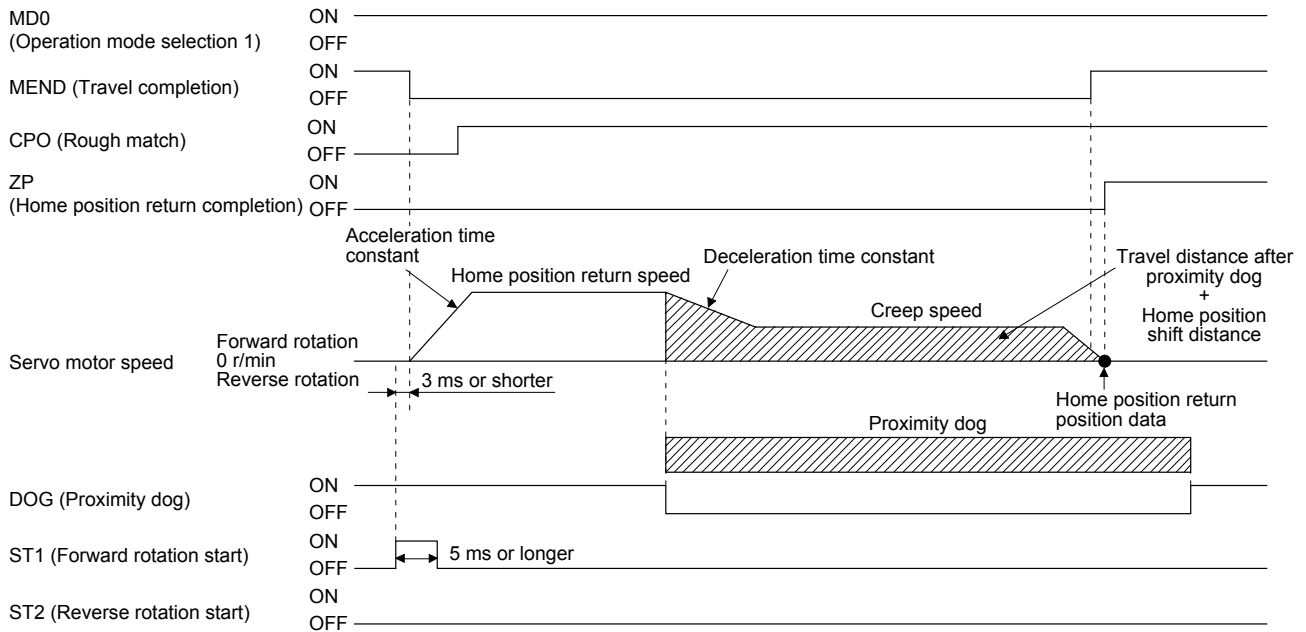

The setting value of [Pr. PT08 Home position return position data] is used as the position address at the home position return completion.

4.4.9 Dog cradle type home position return

You can use the position, which is specified by the first Z-phase signal after the front end of a proximity dog is detected, as the home position.

(1) Device/parameter

Set input devices and parameters as follows.

Item	Used device/parameter	Setting
Home position return mode selection	MD0 (Operation mode selection 1)	Switch on MD0.
	DI0 (Point table No. selection 1) to DI7 (Point table No. selection 8)	Switch off DI0 to DI7.
Dog cradle type home position return	[Pr. PT04]	___ 7: Select the dog cradle type.
Home position return direction	[Pr. PT04]	Refer to section 4.4.1 (2) to select the home position return direction.
Dog input polarity	[Pr. PT29]	Refer to section 4.4.1 (2) to select the dog input polarity.
Home position return speed	[Pr. PT05]	Set the rotation speed until the dog is detected.
Creep speed	[Pr. PT06]	Set the rotation speed after the dog is detected.
Home position shift distance	[Pr. PT07]	Set this item to shift the home position, which is specified by the Z-phase signal.
Home position return acceleration/deceleration time constant	Point table No. 1	Use the acceleration/deceleration time constant of point table No. 1.
Home position return position data	[Pr. PT08]	Set the current position at the home position return completion.

4. HOW TO USE THE POINT TABLE

(2) Timing chart

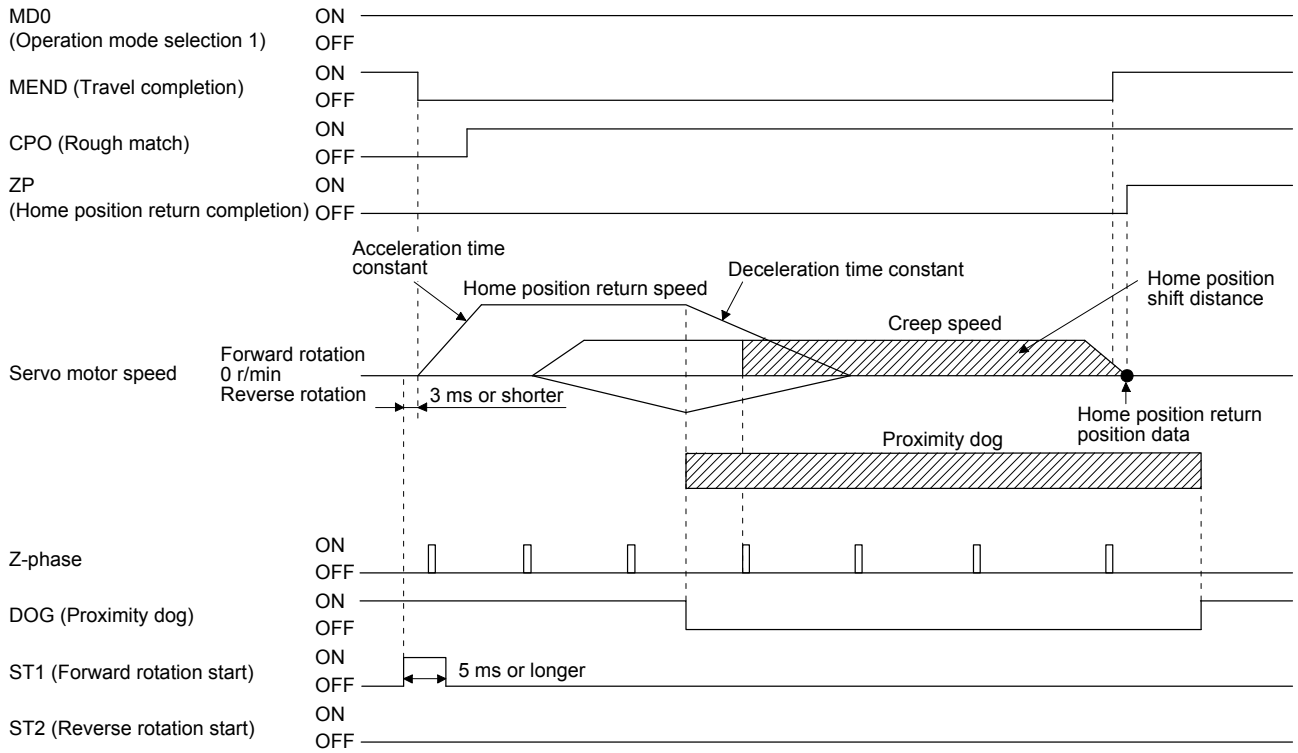

The setting value of [Pr. PT08 Home position return position data] is used as the position address at the home position return completion.

4. HOW TO USE THE POINT TABLE

4.4.10 Dog type last Z-phase reference home position return

After the front end of a proximity dog is detected, the position is shifted away from the proximity dog at the creep speed in the reverse direction and then specified by the first Z-phase signal. The position of the first Z-phase signal is used as the home position.

(1) Device/parameter

Set input devices and parameters as follows.

Item	Used device/parameter	Setting
Home position return mode selection	MD0 (Operation mode selection 1)	Switch on MD0.
	DI0 (Point table No. selection 1) to DI7 (Point table No. selection 8)	Switch off DI0 to DI7.
Dog type last Z-phase reference home position return	[Pr. PT04]	___ 8: Select the dog type last Z-phase reference.
Home position return direction	[Pr. PT04]	Refer to section 4.4.1 (2) to select the home position return direction.
Dog input polarity	[Pr. PT29]	Refer to section 4.4.1 (2) to select the dog input polarity.
Home position return speed	[Pr. PT05]	Set the rotation speed until the dog is detected.
Creep speed	[Pr. PT06]	Set the rotation speed after the dog is detected.
Home position shift distance	[Pr. PT07]	Set this item to shift the home position, which is specified by the Z-phase signal.
Home position return acceleration/deceleration time constant	Point table No. 1	Use the acceleration/deceleration time constant of point table No. 1.
Home position return position data	[Pr. PT08]	Set the current position at the home position return completion.

4. HOW TO USE THE POINT TABLE

(2) Timing chart

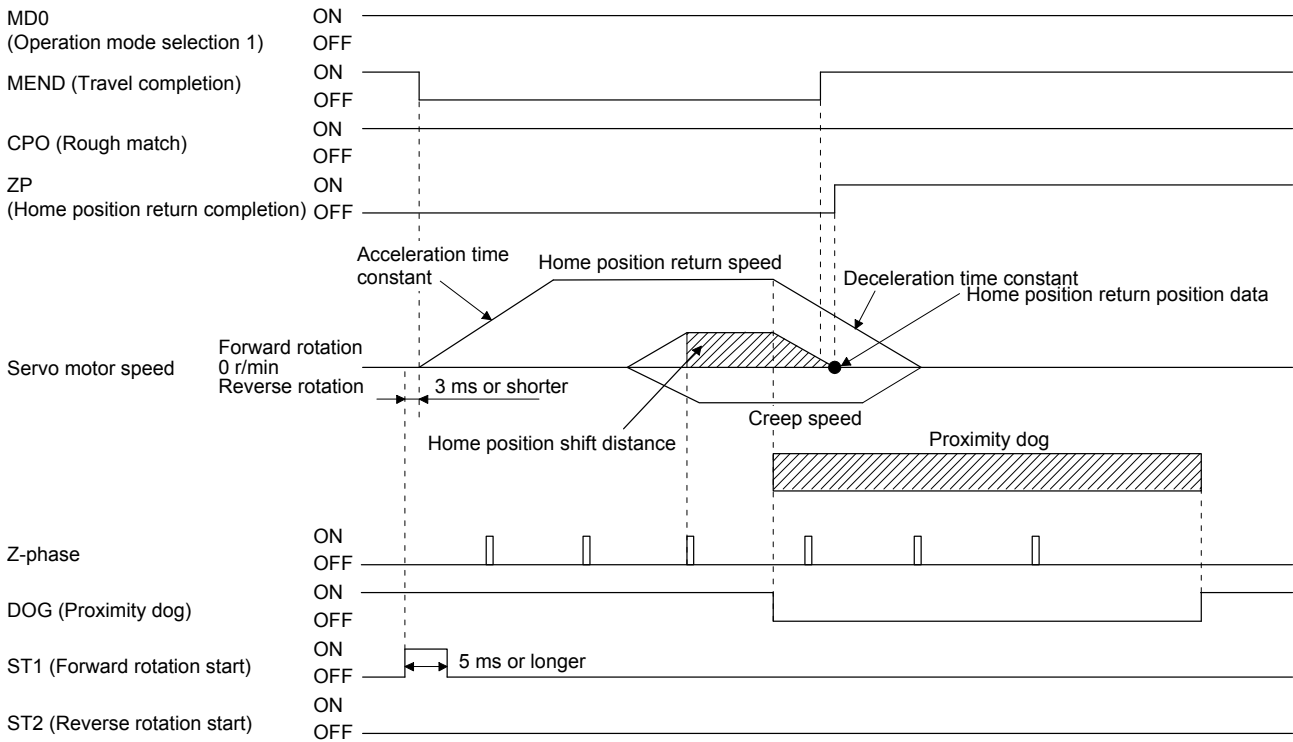

The setting value of [Pr. PT08 Home position return position data] is used as the position address at the home position return completion.

4. HOW TO USE THE POINT TABLE

4.4.11 Dog type front end reference home position return type

POINT
<p>● This home position return method depends on the timing of reading DOG (Proximity dog) that has detected the front end of a proximity dog. Therefore, when a home position return is performed at a creep speed of 100 r/min, the home position has an error of 6400 pulses (for HG series servo motor). The higher the creep speed, the greater the error of the home position.</p>

Starting from the front end of a proximity dog, the position is shifted by the travel distance after proximity dog and the home position shift distance. The position after the shifts is used as the home position. The home position return is available independently of the Z-phase signal. Changing the creep speed may change the home position.

(1) Device/parameter

Set input devices and parameters as follows.

Item	Used device/parameter	Setting
Home position return mode selection	MD0 (Operation mode selection 1)	Switch on MD0.
	DI0 (Point table No. selection 1) to DI7 (Point table No. selection 8)	Switch off DI0 to DI7.
Dog type front end reference home position return	[Pr. PT04]	___ 9: Select the dog type front end reference.
Home position return direction	[Pr. PT04]	Refer to section 4.4.1 (2) to select the home position return direction.
Dog input polarity	[Pr. PT29]	Refer to section 4.4.1 (2) to select the dog input polarity.
Home position return speed	[Pr. PT05]	Set the rotation speed until the dog is detected.
Creep speed	[Pr. PT06]	Set the rotation speed after the dog is detected.
Home position shift distance	[Pr. PT07]	Set this item to shift the home position, which is specified by the Z-phase signal.
Home position return acceleration/deceleration time constant	Point table No. 1	Use the acceleration/deceleration time constant of point table No. 1.
Home position return position data	[Pr. PT08]	Set the current position at the home position return completion.

4. HOW TO USE THE POINT TABLE

(2) Timing chart

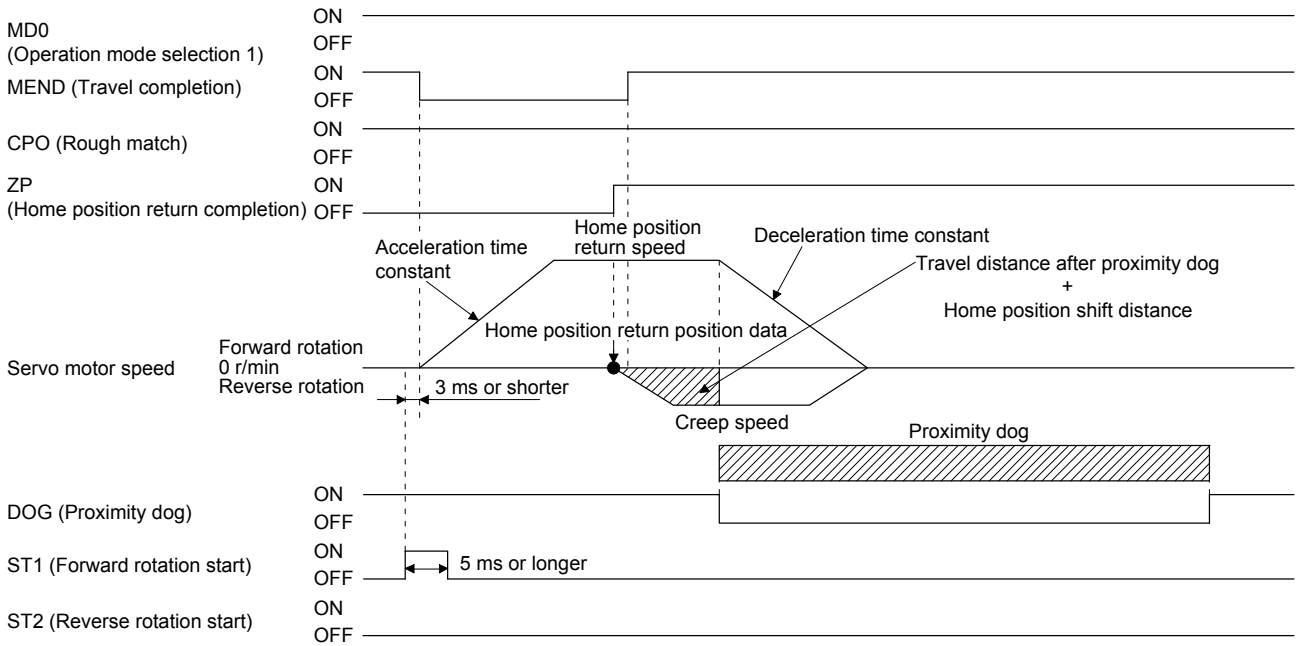

The setting value of [Pr. PT08 Home position return position data] is used as the position address at the home position return completion.

4. HOW TO USE THE POINT TABLE

4.4.12 Dogless Z-phase reference home position return type

Starting from the Z-phase pulse position after the start of the home position return, the position is shifted by the home position shift distance. The position after the shifts is used as the home position.

(1) Device/parameter

Set input devices and parameters as follows.

Item	Used device/parameter	Setting
Home position return mode selection	MD0 (Operation mode selection 1)	Switch on MD0.
	DI0 (Point table No. selection 1) to DI7 (Point table No. selection 8)	Switch off DI0 to DI7.
Dogless Z-phase reference home position return	[Pr. PT04]	___ A: Select the dogless type (Z-phase reference).
Home position return direction	[Pr. PT04]	Refer to section 4.4.1 (2) to select the home position return direction.
Home position return speed	[Pr. PT05]	Set the rotation speed specified until the Z-phase is detected.
Creep speed	[Pr. PT06]	Set the rotation speed specified after the Z-phase is detected.
Home position shift distance	[Pr. PT07]	Set this item to shift the home position, which is specified by the Z-phase signal.
Home position return acceleration/deceleration time constant	Point table No. 1	Use the acceleration/deceleration time constant of point table No. 1.
Home position return position data	[Pr. PT08]	Set the current position at the home position return completion.

(2) Timing chart

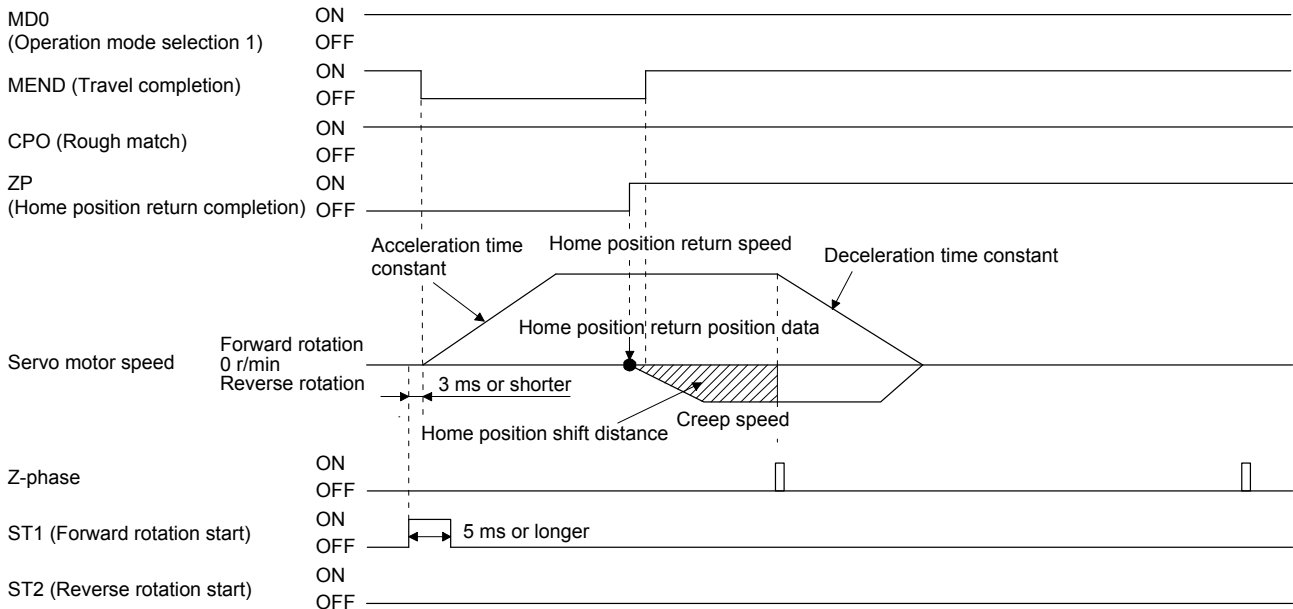

The setting value of [Pr. PT08 Home position return position data] is used as the position address at the home position return completion.

4. HOW TO USE THE POINT TABLE

4.4.13 Automatic retract function used for the home position return

For a home position return using the proximity dog, when the home position return is started from the position on or beyond the proximity dog, the home position return is performed after the machine moves back to the position where the home position can be performed.

(1) When the current position is on the proximity dog

When the current position is on the proximity dog, the machine moves backward automatically, and the home position return is performed.

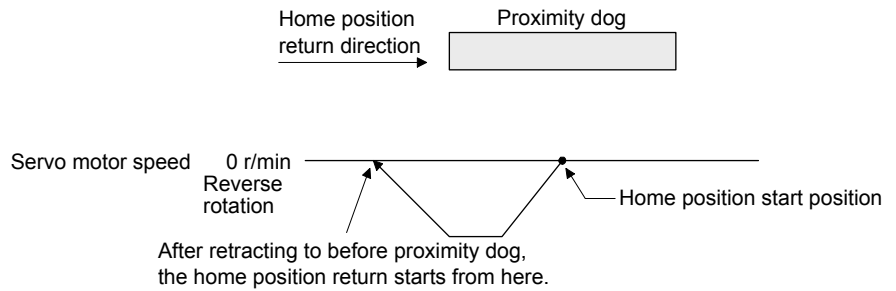

(2) When the current position is beyond the proximity dog

At start-up, the operation is performed in the direction of the home position return. When LSP (Forward rotation stroke end) or LSN (Reverse rotation stroke end) is detected, the machine moves backward automatically. The machine passes and stops before the proximity dog, and the home position return is performed from the position again. If the proximity dog cannot be detected, the machine stops at LSP or LSN on the opposite side, and [AL. 90 Home position return incomplete warning] will occur.

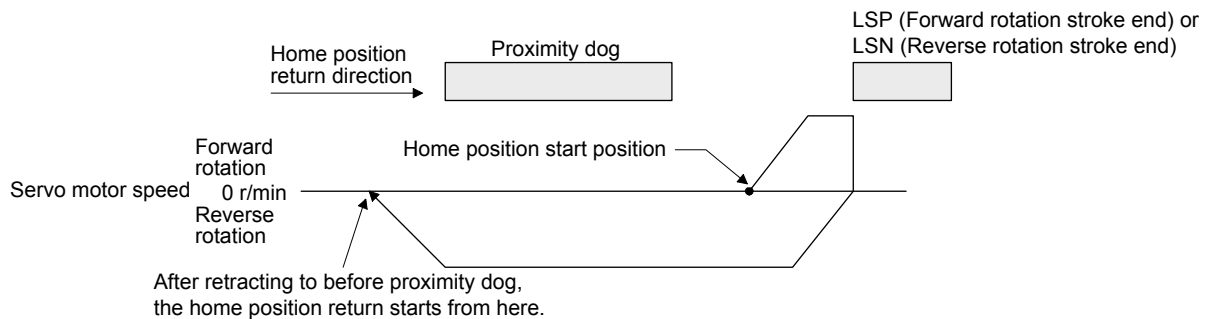

The software limit cannot be used with these functions.

4. HOW TO USE THE POINT TABLE

4.4.14 Automatic positioning to home position function

POINT
<p>● The automatic positioning to the home position cannot be performed from outside the setting range of position data. In this case, perform the home position return again using the home position return.</p>

After power-on, if the home position return is performed again after the home position return is performed to define the home position, this function enables automatic positioning to the home position rapidly. For the absolute position detection system, the home position return is unnecessary after the power-on.

When the automatic positioning to the home position is performed at home position return incompleteness, [AL. 90.1] will occur.

After the power-on, perform the home position return in advance.

Set input devices and parameters as follows.

Item	Used device/parameter	Setting
Home position return mode selection	MD0 (Operation mode selection 1)	Switch on MD0.
	DI0 (Point table No. selection 1) to DI7 (Point table No. selection 8)	Switch off DI0 to DI7.
Home position return speed	[Pr. PT05]	Set the servo motor speed to travel to the home position.
Home position return acceleration/deceleration time constant	Point table No. 1	Use the acceleration/deceleration time constant of point table No. 1.
Home position return direction	[Pr. PT04]	Set the rotation direction in degrees.

Set the home position return speed of the automatic positioning to home position function with [Pr. PT05].

The data of point table No. 1 is used for acceleration/deceleration time constants. Switching on ST2 (Reverse rotation start) enables high-speed automatic return.

Set the rotation direction at the time of degree unit setting with home position return direction of [Pr. PT04].

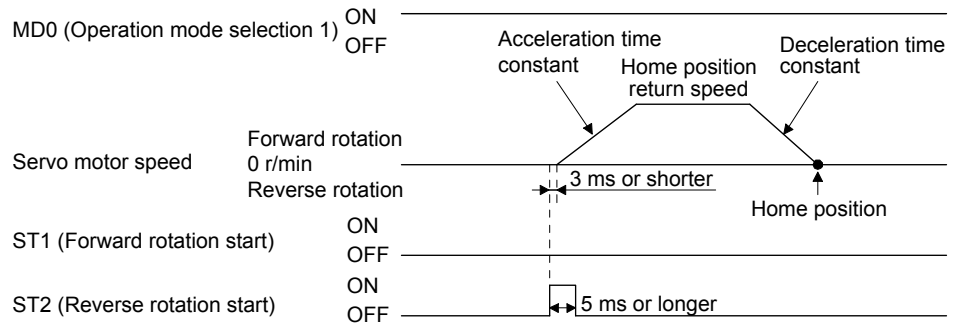

4. HOW TO USE THE POINT TABLE

4.4.15 Precautions for using linear servo motors

POINT
<ul style="list-style-type: none"> ● The incremental linear encoder and the absolute position linear encoder have different reference home positions at the home position return.

(1) Incremental linear encoder

 CAUTION	<ul style="list-style-type: none"> ● If the resolution or the stop interval (the third digit of [Pr. PL01]) of the linear encoder is large, it is very dangerous since the linear servo motor may crash into the stroke end.
--	---

- (a) When the linear encoder home position (reference mark) exists in the home position return direction
 When an incremental linear encoder is used, the home position is the position per 1048576 pulses (changeable with the third digit of [Pr. PL01]) with reference to the linear encoder home position (reference mark) passed through first after a home position return start. Change the setting value of [Pr. PL01] according to the linear encoder resolution.

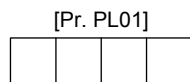

Stop interval setting at the home position return

Setting value	Stop interval [pulse]
0	8192
1	131072
2	262144
3	1048576 (initial value)
4	4194304
5	16777216
6	67108864

4. HOW TO USE THE POINT TABLE

The following shows the relation between the stop interval at the home position return and the linear encoder resolution. For example, when the linear encoder resolution is 0.001 μm and the parameter for the stop interval at the home position return, [Pr. PL01], is set to "_ 5 _" (16777216 pulses), the stop interval is 16.777 mm. The value inside a bold box indicates the recommended stop interval for each linear encoder resolution.

[Unit: mm]

Pr. PL01	Linear encoder resolution [μm] Stop interval [pulse]	0.001	0.005	0.01	0.02	0.05	0.1	0.2	0.5	1	2
_ 0 _	8192	0.008	0.041	0.082	0.164	0.410	0.819	1.638	4.096	8.192	16.384
_ 1 _	131072	0.131	0.655	1.311	2.621	6.554	13.107	26.214	65.536	131.072	262.144
_ 2 _	262144	0.262	1.311	2.621	5.243	13.107	26.214	52.429	131.072	262.144	524.288
_ 3 _	1048576	1.049	5.243	10.486	20.972	52.429	104.858	209.715	524.288	1048.576	2097.152
_ 4 _	4194304	4.194	20.972	41.943	83.886	209.715	419.430	838.861	2097.152	4194.304	8388.608
_ 5 _	16777216	16.777	83.886	167.772	335.544	838.861	1677.722	3355.443	8388.608	16777.216	33554.432
_ 6 _	67108864	67.109	335.544	671.089	1342.177	3355.443	6710.886	13421.773	33554.432	67108.864	134217.728

In the case of a dog type home position return, after the proximity dog signal rear end is detected, the nearest home position reference position shifted by the home position shift distance is used as the home position.

Set one linear encoder home position in the full stroke, and set it in the proximity dog signal detection position.

When two or more reference marks exist during the full stroke of the linear encoder, select "Enabled (1 _ _)" of "Linear scale multipoint Z-phase input function selection" in [Pr. PC28].

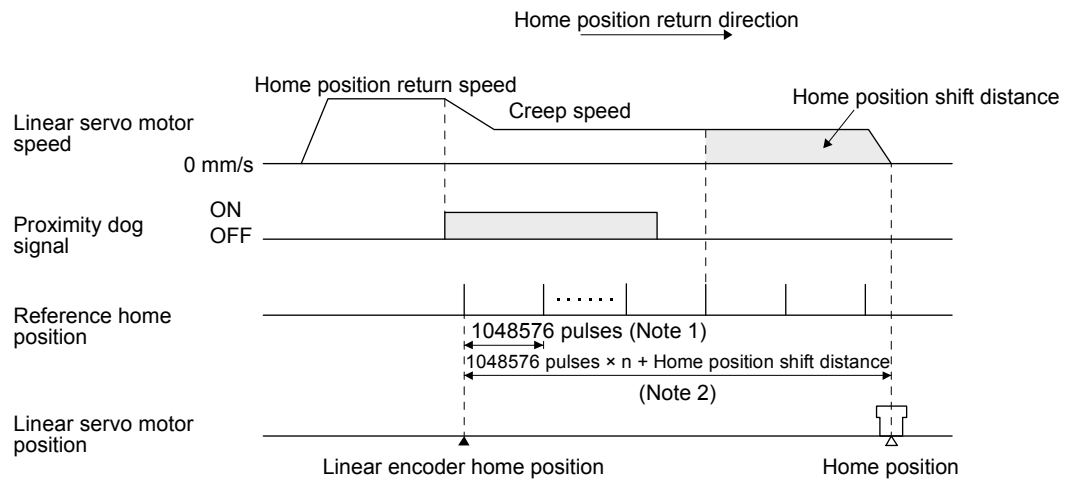

Note 1. Changeable with [Pr. PL01].

Note 2. Home position shift distance can be changed with [Pr. PT07] and [Pr. PT69].

4. HOW TO USE THE POINT TABLE

(b) When the linear encoder home position does not exist in the home position return direction

POINT
<ul style="list-style-type: none"> ● To execute a home position return securely, start a home position return after moving the linear servo motor to the opposite stroke end with JOG operation from the controller and others. ● Change the third digit value of [Pr. PL01] according to the linear encoder resolution.

If the home position return is performed from the position where the linear encoder home position does not exist in the home position return direction, an error may occur depending on the home position return type. In this case, change the home position return type, or move the mover to the stroke end on the opposite side of the home position return direction with the JOG operation from the controller and others, and then perform a home position return.

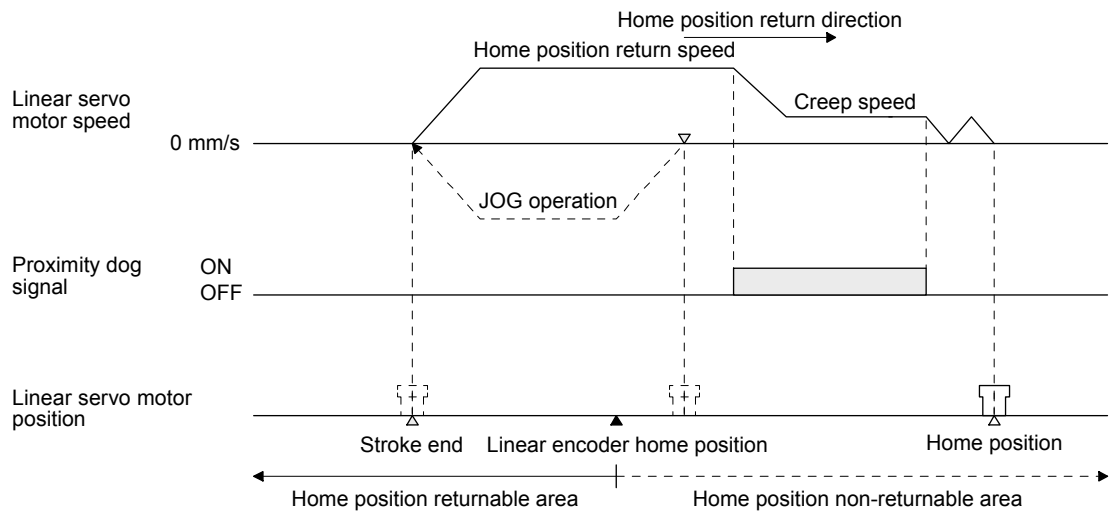

4. HOW TO USE THE POINT TABLE

(2) Absolute position linear encoder

POINT
●The data set type home position return can also be carried out.

When an absolute linear encoder is used, the reference home position is the position per 1048576 pulses (changeable with the third digit of [Pr. PL01]) with reference to the linear encoder home position (absolute position data = 0).

In the case of a proximity dog type home position return, the nearest reference home position after proximity dog off is the home position. The linear encoder home position can be set in any position. LZ (Encoder Z-phase pulse) is outputted based on "Stop interval selection at the home position return" in [Pr. PL01].

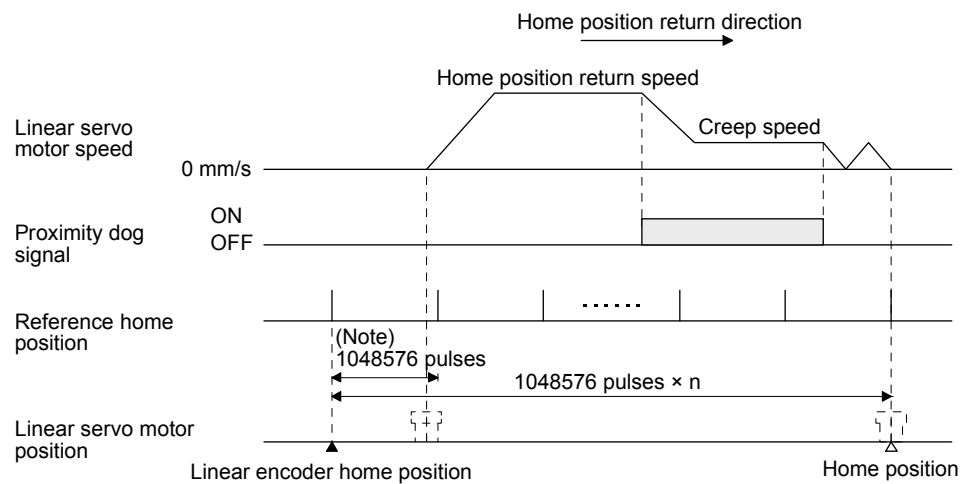

Note. Changeable with [Pr. PL01].

4. HOW TO USE THE POINT TABLE

4.4.16 Precautions for using the fully closed loop system

(1) General instruction

Home position return is all performed according to the load-side encoder feedback data, independently of the load-side encoder type. It is irrelevant to the Z-phase position of the servo motor encoder. In the case of a home position return using a dog signal, the home position (reference mark) must be passed through when an incremental type linear encoder is used, or the Z-phase be passed through when a rotary encoder is used, during a period from a home position return start until the dog signal turns off.

(2) Load-side encoder types and home position return methods

(a) About proximity dog type home position return using absolute type linear encoder

When an absolute type linear encoder is used, the home position reference position is the position per servo motor revolution to the linear encoder home position (absolute position data = 0).

In the case of a proximity dog type home position return, the nearest position after proximity dog off is the home position.

The linear encoder home position may be set in any position.

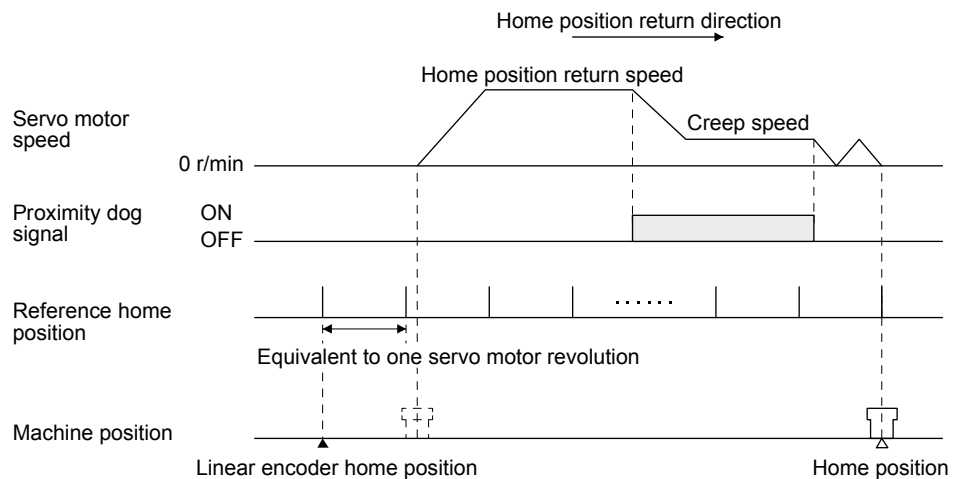

4. HOW TO USE THE POINT TABLE

(b) About proximity dog type home position return using incremental linear encoder

POINT
<ul style="list-style-type: none"> ● To execute a home position return securely, start a home position return after moving the axis to the opposite stroke end by jog operation, etc. of the controller. ● If the incremental linear encoder does not have a linear encoder home position (reference mark), only the home position return type without using Z-phase can be performed.

1) When the linear encoder home position (reference mark) exists in the home position return direction

When an incremental linear encoder is used, the home position is the position per servo motor revolution to the linear encoder home position (reference mark) passed through first after a home position return start.

In the case of a dog type home position return, after the proximity dog signal rear end is detected, the nearest home position reference position shifted by the home position shift distance is used as the home position.

Set one linear encoder home position in the full stroke, and set it in the proximity dog signal detection position.

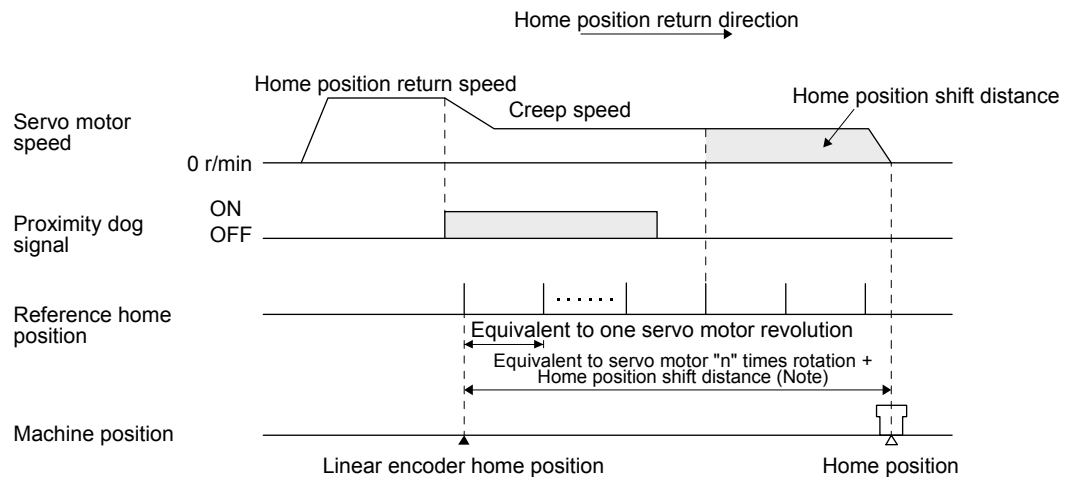

Note. Home position shift distance can be changed with [Pr. PT07] and [Pr. PT69].

4. HOW TO USE THE POINT TABLE

- 2) When the linear encoder home position does not exist in the home position return direction
 If the home position return is performed from the position where the linear encoder home position does not exist in the home position return direction, an error may occur depending on the home position return type. In this case, change the home position return type, or move the mover to the stroke end on the opposite side of the home position return direction with the JOG operation from the controller and others, and then perform a home position return.

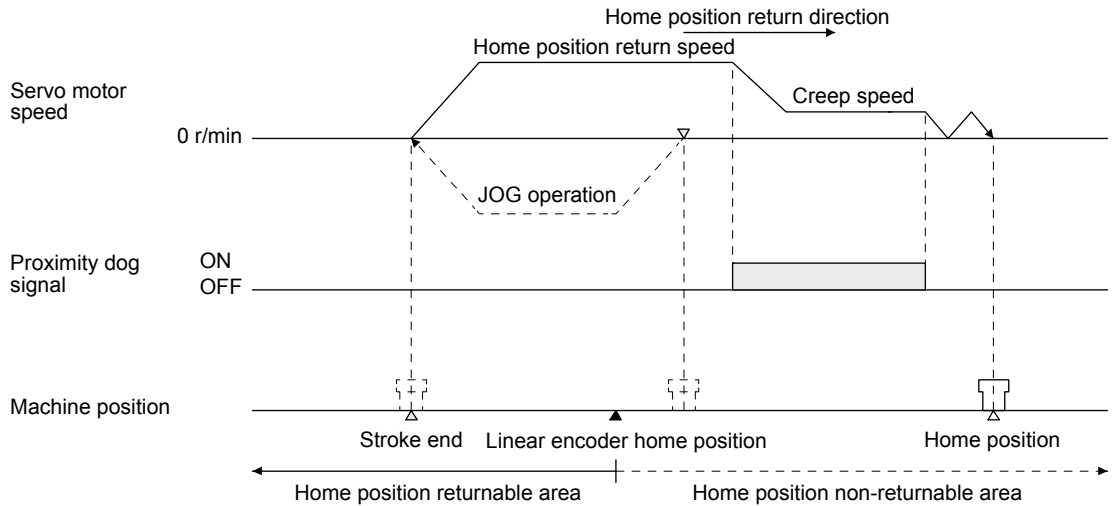

- (c) About dog type home position return when using the rotary encoder of a serial communication servo motor

The home position for when using the rotary encoder of a serial communication servo motor for the load-side encoder is at the load-side Z-phase position.

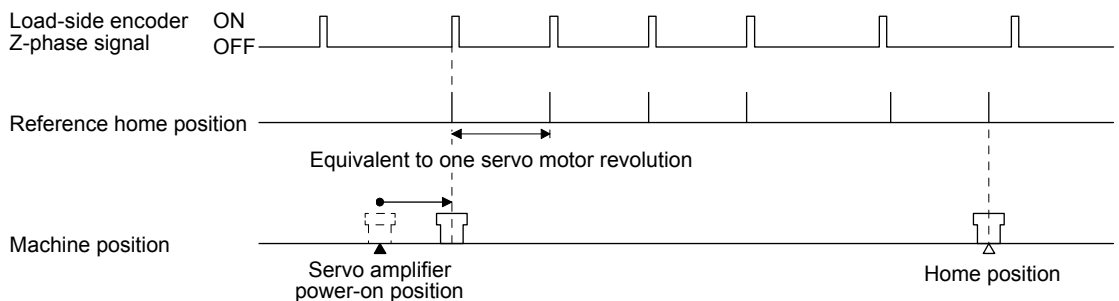

4. HOW TO USE THE POINT TABLE

4.5 Roll feed mode using the roll feed display function

The roll feed display function can change the current position of the status monitor and command position display.

Using the roll feed display function can use this servo amplifier as the roll feed mode. The roll feed mode can be used in the incremental system. Using the override function can change the feed speed during operation. Refer to section 2.4 for details.

(1) Parameter setting

No.	Name	Setting digit	Setting item	Setting value	Setting
PA03	Absolute position detection system	___ x	Absolute position detection system	___ 0 (initial value)	Always set the incremental system. It cannot be used by the absolute position detection system.
PT26	Current position/command position display selection	__ x _	Current position/command position display selection	__ 1 _	Select the roll feed display.
PT26	Electronic gear fraction clear selection	___ x	Electronic gear fraction clear selection	___ 1	Clear a fraction of the previous command by the electronic gear at start of the automatic operation. Always set "___ 1" (enabled) in the electronic gear fraction clear.

(2) Roll feed display function

When the roll feed display function is used, the status display of the current position and command position at start will be 0.

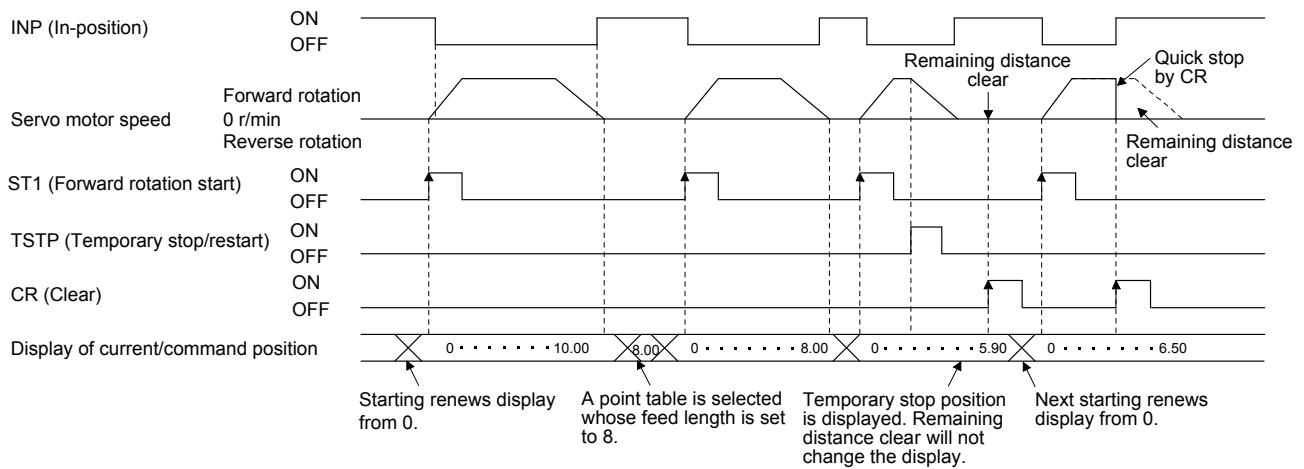

4. HOW TO USE THE POINT TABLE

(3) Position data unit

The display unit is expressed in the unit set in [Pr. PT26], and the feed length multiplication is expressed in the unit set in [Pr. PT03].

When the unit is set in degrees, the roll feed display function is disabled.

Refer to section 4.2.2 for details.

(4) Operation method

Only the status display of the current position and command position changes. The operation method is the same as each operation mode.

Operation mode		Detailed explanation
Automatic operation	Automatic operation using the point table	Section 4.2.2
Manual operation	JOG operation	Section 4.3.1
	Manual pulse generator operation	Section 4.3.2
Home position return mode		Section 4.4

4. HOW TO USE THE POINT TABLE

4.6 Point table setting method

The following shows the setting method of point tables using MR Configurator2.

4.6.1 Setting procedure

Click "Positioning-data" in the menu bar and click "Point Table" in the menu.

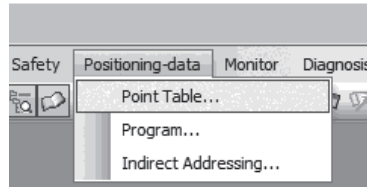

The following window will be displayed by clicking.

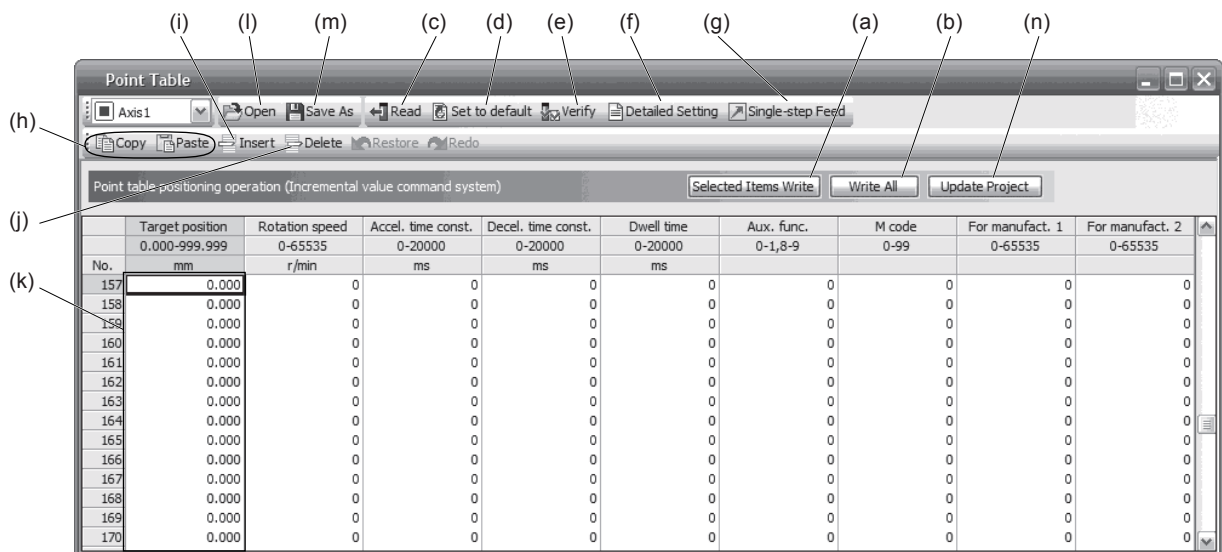

(1) Writing point table data (a)

Select changed point table data and click "Selected Items Write" to write the changed point table data to the servo amplifier.

(2) Writing all point table data (b)

Click "Write All" to write all the point table data to the servo amplifier.

(3) Reading all point table data (c)

Click "Read" to read and display all the point table data from the servo amplifier.

(4) Initial setting of point table data (d)

Click "Set to default" to initialize all the data of point table No. 1 to 255. This also initializes data currently being changed.

4. HOW TO USE THE POINT TABLE

- (5) Verifying point table data (e)
Click "Verify" to verify all the data displayed and data of the servo amplifier.
- (6) Detailed setting of point table data (f)
Click "Detailed Setting" to change position data range and unit in the point table window. Refer to section 4.6.2 for details.
- (7) Single-step feed (g)
Click "Single-step Feed" to perform the single-step feed test operation. Refer to section 3.1.9 or 3.2.9 for details.
- (8) Copy and paste of point table data (h)
Click "Copy" to copy the selected point table data. Click "Paste" to paste the copied point table data.
- (9) Inserting point table data (i)
Click "Insert" to insert a block to the previous row from the selected point table No. The selected point table No. and lower rows will be shifted down one by one.
- (10) Deleting point table data (j)
Click "Delete" to delete all the data of the point table No. selected. The lower rows of the selected point table No. will be shifted up one by one.
- (11) Changing point table data (k)
After selecting the data to be changed, enter a new value, and click "Enter". You can change the displayed range and unit with "(6) Detailed setting of point table data" of this section.
- (12) Reading point table data (l)
Click "Open" to read the point table data.
- (13) Saving point table data (m)
Click "Save As" to save the point table data.
- (14) Updating project (n)
Click "Update Project" to update the point table data to a project.

4. HOW TO USE THE POINT TABLE

4.6.2 Detailed setting window

You can change position data range and unit with the detailed setting for the point table window. For the position data range and unit of [Pr. PT01] setting, refer to section 4.2.2. To reflect the setting for the corresponding parameter, click "Update Project" in the point table window.

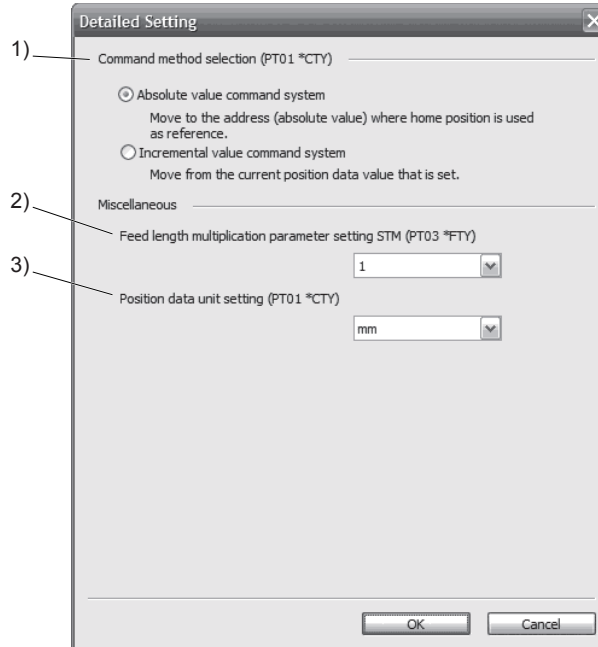

(1) Command method selection (PT01 *CTY) 1)

Select a positioning command method from the absolute position command method and incremental value command method.

(2) Miscellaneous

(a) Feed length multiplication parameter setting STM (PT03 *FTY) 2)

Select any feed length multiplication from 1/10/100/1000.

(b) Position data unit setting (PT01 *CTY) 3)

Select any unit of position data from mm/inch/degree/pulse. While degree or pulse is selected, setting of feed length multiplication will be disabled.

5. HOW TO USE THE PROGRAM

5. HOW TO USE THE PROGRAM

The following items are the same as MR-J4-_A_-RJ servo amplifiers. For details, refer to each section indicated in the detailed explanation field. "MR-J4-_A_" means "MR-J4-_A_(-RJ) Servo Amplifier Instruction Manual".

Item	Detailed explanation	
	MR-J4-_A_-RJ 100 W or more	MR-J4-03A6-RJ
Switching power on for the first time	MR-J4-_A_ section 4.1	MR-J4-_A_ section 18.4

POINT
<ul style="list-style-type: none"> ● When you use a linear servo motor, replace the following left words to the right words. <ul style="list-style-type: none"> Load to motor inertia ratio → Load to motor mass ratio Torque → Thrust (Servo motor) speed → (Linear servo motor) speed ● For the mark detection function (Current position latch), refer to section 12.2.1. ● For the mark detection function (Interrupt positioning), refer to section 12.2.2. ● For the infinite feed function (setting degree), refer to section 12.3.

5.1 Startup

5.1.1 Power on and off procedures

When the servo amplifier is powered on for the first time, the amplifier enters the position control mode. (Refer to section 4.2.1 of "MR-J4-_A_(-RJ) Servo Amplifier Instruction Manual".)

This section provides a case where the servo amplifier is powered on after the positioning mode setting.

(1) Power-on

Switch power on in the following procedure. Always follow this procedure at power-on.

- 1) Switch off SON (Servo-on).
- 2) Make sure that ST1 (Forward rotation start) is off.
- 3) Switch on the main circuit power supply and control circuit power supply.
The display shows "PoS" ("PSL" for MR-J4-03A6-RJ servo amplifiers), and in 2 s later, shows data.

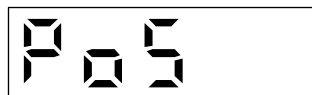

MR-J4-_A_-RJ 100 W or more



MR-J4-03A6-RJ

(2) Power-off

- 1) Switch off ST1 (Forward rotation start).
- 2) Switch off SON (Servo-on).
- 3) Switch off the main circuit power supply and control circuit power supply.

5. HOW TO USE THE PROGRAM

5.1.2 Stop

If any of the following situations occurs, the servo amplifier suspends the running of the servo motor and brings it to a stop.

Refer to section 3.10 of "MR-J4- _A_(-RJ) Servo Amplifier Instruction Manual" for the servo motor with an electromagnetic brake.

Operation/command	Stopping condition
Switch off SON (Servo-on).	The base circuit is shut off and the servo motor coasts.
Alarm occurrence	The servo motor decelerates to a stop with the command. With some alarms, however, the dynamic brake operates to bring the servo motor to a stop. (Refer to chapter 8. (Note 1))
EM2 (Forced stop 2) off	The servo motor decelerates to a stop with the command. [AL. E6 Servo forced stop warning] occurs. Refer to section 2.3 for EM1.
STO (STO1, STO2) off (Note 2)	The base circuit is shut off and the dynamic brake operates to bring the servo motor to a stop.
LSP (Forward rotation stroke end) off, LSN (Reverse rotation stroke end) off	It will bring the motor to a sudden stop and make it servo-locked. It can be run in the opposite direction.

Note 1. Only a list of alarms and warnings is listed in chapter 8. Refer to "MELSERVO-J4 Servo Amplifier Instruction Manual (Troubleshooting)" for details of alarms and warnings.

2. MR-J4-03A6-RJ servo amplifiers are not compatible with the STO function.

5. HOW TO USE THE PROGRAM

5.1.3 Test operation

Before starting actual operation, perform test operation to make sure that the machine operates normally. Refer to section 5.1.1 for how to power on and off the servo amplifier.

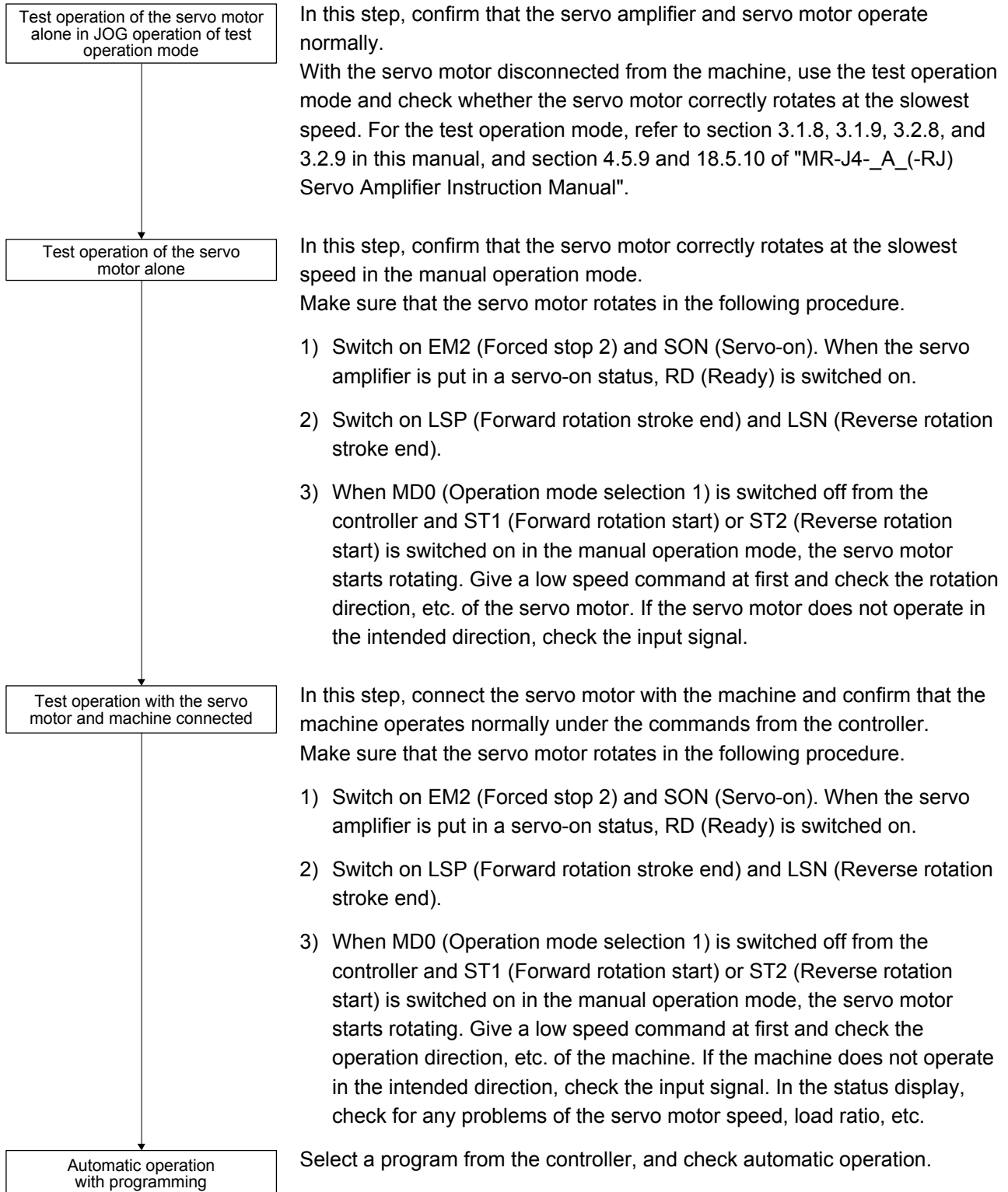

5. HOW TO USE THE PROGRAM

5.1.4 Parameter setting

POINT
<ul style="list-style-type: none"> ● The following encoder cables are of four-wire type. When using any of these encoder cables, set [Pr. PC22] to "1 ___" to select the four-wire type. Incorrect setting will result in [AL. 16 Encoder initial communication error 1]. MR-EKCBL30M-L MR-EKCBL30M-H MR-EKCBL40M-H MR-EKCBL50M-H ● Assign the following output devices to the CN1-22, CN1-23, and CN1-25 pins with [Pr. PD23], [Pr. PD24], and [Pr. PD26]. CN1-22: CPO (Rough match) CN1-23: ZP (Home position return completion) CN1-25: MEND (Travel completion)

When using this servo by the program method, set [Pr. PA01] to "___7" (Positioning mode (program method)). For the program method, the servo can be used by merely changing the basic setting parameters ([Pr. PA __]) and positioning control parameters ([Pr. PT __]) mainly.

As necessary, set other parameters.

The following table shows [Pr. PA __] and [Pr. PT __] settings required for the program method.

Operation mode selection item		Parameter setting		Input device setting	
		[Pr. PA01]	[Pr. PT04]	MD0 (Note 1)	DI0 to DI7 (Note 1)
Operation mode				On	Any
Automatic operation mode of the program method				Off	
Manual operation mode	JOG operation				
	Manual pulse generator operation				
Home position return	Dog type	___7	___0	On	Any (Note 2)
	Count type		___1		
	Data set type		___2		
	Stopper type		___3		
	Home position ignorance (servo-on position as home position)		___4		
	Dog type rear end reference		___5		
	Count type front end reference		___6		
	Dog cradle type		___7		
	Dog type last Z-phase reference		___8		
	Dog type front end reference		___9		
	Dogless Z-phase reference		___A		

Note 1. MD0: Operation mode selection 1, DI0 to DI7: Program No. selection 1 to Program No. selection 8

2. Select a program containing a "ZRT" command, which performs the home position return.

5. HOW TO USE THE PROGRAM

5.1.5 Actual operation

Start actual operation after confirmation of normal operation by test operation and completion of the corresponding parameter settings.

5.1.6 Troubleshooting at start-up



CAUTION ● Never make a drastic adjustment or change to the parameter values as doing so will make the operation unstable.

POINT

● Using MR Configurator2, you can refer to the reason for rotation failure, etc.

The following faults may occur at start-up. If any of such faults occurs, take the corresponding action. "MR-J4- _A_" means "MR-J4- _A_(-RJ) Servo Amplifier Instruction Manual".

No.	Start-up sequence	Fault	Investigation	Possible cause	Reference
1	Power on	<ul style="list-style-type: none"> • The 7-segment LED display does not turn on. • The 7-segment LED display flickers. 	Not improved even if CN1, CN2, and CN3 connectors are disconnected.	1. Power supply voltage fault 2. The servo amplifier is malfunctioning.	/
			Improved when CN1 connector is disconnected.	Power supply of CN1 cabling is shorted.	
			Improved when CN2 connector is disconnected.	1. Power supply of encoder cabling is shorted. 2. Encoder is malfunctioning.	
			Improved when CN3 connector is disconnected.	Power supply of CN3 cabling is shorted.	
		Alarm occurs.	Refer to chapter 8 and remove the cause.		Chapter 8 (Note)
2	Switch on SON (Servo-on).	Alarm occurs.	Refer to chapter 8 and remove the cause.		Chapter 8 (Note)
		Servo motor shaft is not servo-locked. (Servo motor shaft is free.)	1. Check the display to see if the servo amplifier is ready to operate. 2. Check the external I/O signal indication (section 3.1.7 or 3.2.7) to see if SON (Servo-on) is on.	1. SON (Servo-on) is not input. (wiring mistake) 2. 24 V DC power is not supplied to DICOM.	Section 3.1.7 Section 3.2.7
3	Perform a home position return.	Servo motor does not rotate.	Call the external I/O signal display and check the on/off status of the input signal. (Refer to section 3.1.7 or 3.2.7.)	LSP, LSN, and ST1 are off.	Section 3.1.7 Section 3.2.7
			Check [Pr. PA11 Forward rotation torque limit] and [Pr. PA12 Reverse rotation torque limit].	Torque limit level is too low as compared to the load torque.	Section 7.2.1
			When TLA (Analog torque limit) is usable, check the input voltage on the status display.	Torque limit level is too low as compared to the load torque.	Section 3.1.2 Section 3.2.2
		The home position return is not completed.	Call the external I/O signal display and check the on/off status of input signal DOG. (Refer to section 3.1.7 or 3.2.7.)	The proximity dog is set incorrectly.	Section 3.1.7 Section 3.2.7

5. HOW TO USE THE PROGRAM

No.	Start-up sequence	Fault	Investigation	Possible cause	Reference
4	Switch on ST1 (Forward rotation start).	Servo motor does not rotate.	Call the external I/O signal display (Section 3.1.7 or 3.2.7) and check the on/off status of the input signal.	LSP, LSN, and ST1 are off.	Section 3.1.7 Section 3.2.7
			Check [Pr. PA11 Forward rotation torque limit] and [Pr. PA12 Reverse rotation torque limit].	Torque limit level is too low as compared to the load torque.	Section 7.2.1
			When TLA (Analog torque limit) is usable, check the input voltage on the status display.	Torque limit level is too low as compared to the load torque.	Section 3.1.2 Section 3.2.2
5	Gain adjustment	Rotation ripples (speed fluctuations) are large at low speed.	Make gain adjustment in the following procedure. 1. Increase the auto tuning response level. 2. Repeat acceleration/ deceleration more than three times to complete auto tuning.	Gain adjustment fault	MR-J4- <u>A</u> Chapter 6
		Large load inertia moment causes the servo motor shaft to oscillate side to side.	If the servo motor may be driven with safety, repeat acceleration and deceleration three times or more to complete the auto tuning.	Gain adjustment fault	MR-J4- <u>A</u> Chapter 6

Note. Only a list of alarms and warnings is listed in chapter 8. Refer to "MELSERVO-J4 Servo Amplifier Instruction Manual (Troubleshooting)" for details of alarms and warnings.

5.2 Program operation method

5.2.1 Program operation method

In advance, select a program created on MR Configurator2 by using an input signal or communication to start operation with ST1 (Forward rotation start).

This servo amplifier is factory set to the absolute value command method.

For the position data, you can set the absolute value travel command ("MOV" command), which specifies the target address, and the incremental value travel command ("MOVI" command), which specifies the travel distance. Refer to section 4.2.1 (1) and 5.2.3 (1) (a) for the movable range and the setting unit.

5. HOW TO USE THE PROGRAM

5.2.2 Program language

The maximum number of steps of a program is 640. Up to 256 programs can be created; however, the total number of the steps of all programs must be 640 or less.

A set program is selectable by using DI0 (Program No. selection 1) to DI7 (Program No. selection 8).

(1) Command list

Command	Name	Setting	Setting range	Unit	Indirect specification (Note 7)	Description								
SPN (Note 2)	Servo motor speed	SPN (Setting value)	0 to permissible instantaneous speed	r/min or mm/s (Note 9)	○	Set the servo motor speed for positioning using this command. The setting value must be the permissible instantaneous speed or less of the servo motor used. If the setting value is unspecified, the servo motor rotates at 50 r/min.								
STA (Note 2)	Acceleration time constant	STA (Setting value)	0 to 20000	ms	○	Set the acceleration time constant. The setting value is the time from when the used servo motor stops until when its speed reaches the rated speed. The value cannot be changed during a command output. If the setting value is unspecified, 1000 ms is applied.								
STB (Note 2)	Deceleration time constant	STB (Setting value)	0 to 20000	ms	○	Set the deceleration time constant. The setting value is the time from when the used servo motor rotates at the rated speed until when the motor stops. The value cannot be changed during a command output. If the setting value is unspecified, 1000 ms is applied.								
STC (Note 2)	Acceleration/ deceleration time constant	STC (Setting value)	0 to 20000	ms	○	Set the acceleration/deceleration time constants. The setting value is a time period that the servo motor reaches the rated speed from a stop, and stops from the rated speed. When this command is used, the acceleration time constant and the deceleration time constant become the same. To set the acceleration/deceleration time constants individually, use the "STA" and "STB" commands. The value cannot be changed during a command output. If the setting value is unspecified, 1000 ms is applied.								
STD (Note 2, 5)	S-pattern acceleration/ deceleration time constant	STD (Setting value)	0 to 1000	ms	○	Set the S-pattern acceleration/deceleration time constants. Set this command to insert S-pattern acceleration/deceleration time constants against the acceleration/deceleration time constants of the program.								
MOV	Absolute value travel command	MOV (Setting value)	-999999 to 999999 (Note 6)	$\times 10^{\text{STM}}$ μm (Note 6)	○	The servo motor rotates using the set value as the absolute value.								
MOVA	Absolute value continuous travel command	MOV (Setting value)	-999999 to 999999 (Note 6)	$\times 10^{\text{STM}}$ μm (Note 6)	○	The servo motor rotates continuously using the set value as the absolute value. Make sure to describe this command after the "MOV" command.								
MOVI	Incremental value travel command	MOVI (Setting value)	-999999 to 999999 (Note 6)	$\times 10^{\text{STM}}$ μm (Note 6)	○	The servo motor rotates using the set value as the incremental value. When a negative value is set, the servo motor rotates in the reverse rotation direction. For the reverse rotation, the servo motor rotates in the address decreasing direction.								
MOVIA	Incremental value continuous travel command	MOVIA (Setting value)	-999999 to 999999 (Note 6)	$\times 10^{\text{STM}}$ μm (Note 6)	○	The servo motor rotates continuously using the set value as the incremental value. Make sure to describe this command after the "MOVI" command.								
SYNC (Note 1)	External signal on wait	SYNC (Setting value)	1 to 3			The following steps stop after SOUT (SYNC synchronous output) is output until PI1 (Program input 1) to PI3 (Program input 3) are switched on. <table border="1" style="margin-left: auto; margin-right: auto;"> <thead> <tr> <th>Setting value</th> <th>Input signal</th> </tr> </thead> <tbody> <tr> <td>1</td> <td>PI1 (Program input 1)</td> </tr> <tr> <td>2</td> <td>PI2 (Program input 2)</td> </tr> <tr> <td>3</td> <td>PI3 (Program input 3)</td> </tr> </tbody> </table>	Setting value	Input signal	1	PI1 (Program input 1)	2	PI2 (Program input 2)	3	PI3 (Program input 3)
Setting value	Input signal													
1	PI1 (Program input 1)													
2	PI2 (Program input 2)													
3	PI3 (Program input 3)													

5. HOW TO USE THE PROGRAM

Command	Name	Setting	Setting range	Unit	Indirect specification (Note 7)	Description								
OUTON (Note 1, 3)	External signal on output	OUTON (Setting value)	1 to 3			<p>Switch on OUT1 (Program output 1) to OUT3 (Program output 3). By setting the on time by using [Pr. PT23] to [Pr. PT25], you can switch off the input signals after the set time elapses.</p> <table border="1"> <thead> <tr> <th>Setting value</th> <th>Input signal</th> </tr> </thead> <tbody> <tr> <td>1</td> <td>OUT1 (Program output 1)</td> </tr> <tr> <td>2</td> <td>OUT2 (Program output 2)</td> </tr> <tr> <td>3</td> <td>OUT3 (Program output 3)</td> </tr> </tbody> </table>	Setting value	Input signal	1	OUT1 (Program output 1)	2	OUT2 (Program output 2)	3	OUT3 (Program output 3)
Setting value	Input signal													
1	OUT1 (Program output 1)													
2	OUT2 (Program output 2)													
3	OUT3 (Program output 3)													
OUTOF (Note 1)	External signal off output	OUTOF (Setting value)	1 to 3			<p>Switch off OUT1 (Program output 1) to OUT3 (Program output 3), which have been on by the "OUTON" command.</p> <table border="1"> <thead> <tr> <th>Setting value</th> <th>Input signal</th> </tr> </thead> <tbody> <tr> <td>1</td> <td>OUT1 (Program output 1)</td> </tr> <tr> <td>2</td> <td>OUT2 (Program output 2)</td> </tr> <tr> <td>3</td> <td>OUT3 (Program output 3)</td> </tr> </tbody> </table>	Setting value	Input signal	1	OUT1 (Program output 1)	2	OUT2 (Program output 2)	3	OUT3 (Program output 3)
Setting value	Input signal													
1	OUT1 (Program output 1)													
2	OUT2 (Program output 2)													
3	OUT3 (Program output 3)													
TRIP (Note 1)	Absolute value trip point specification	TRIP (Setting value)	-999999 to 999999 (Note 6)	$\times 10^{\text{STM}}$ μm (Note 6)		When the servo motor rotates for the travel distance set by the "TRIP" command after the "MOV" or "MOVA" command is initiated, the next step is executed. Make sure to describe this command after the "MOV" or "MOVA" command.								
TRIP1 (Note 1)	Incremental value trip point specification	TRIP1 (Setting value)	-999999 to 999999 (Note 6)	$\times 10^{\text{STM}}$ μm (Note 6)		When the servo motor rotates for the travel distance set by the "TRIP1" command after the "MOVI" or "MOVIA" command is initiated, the next step is executed. Make sure to describe this command after the "MOVI" or "MOVIA" command.								
ITP (Note 1, 4)	Interrupt positioning	ITP (Setting value)	0 to 999999 (Note 6)	$\times 10^{\text{STM}}$ μm (Note 6)		An interrupt signal stops the servo motor when the motor rotates the set travel distance. Make sure to describe this command after the "SYNC" command.								
COUNT (Note 1)	External pulse count	COUNT (Setting value)	-999999 to 999999	pulse		When the pulse counter value becomes larger than the count value set for the "COUNT" command, the next step is executed. "COUNT (0)" clears the pulse counter to 0.								
FOR NEXT	Step repeat instruction	FOR (Setting value) NEXT	0, 1 to 10000	times		<p>The steps between the "FOR (Setting value)" and the "NEXT" commands are repeated for the set number of times. Setting "0" repeats the operation endlessly. Do not describe a "FOR" instruction between the "FOR" and "NEXT" commands. Otherwise, an error occurs.</p>								
LPOS (Note 1)	Current position latch	LPOS				<p>Latch the current position at the rising edge of LPS (Current position latch). The latched current position data can be read with communication commands. When the servo motor starts rotating, the latched position varies according to the motor speed and the sampling of input signals.</p>								
TIM	Dwell	TIM (Setting value)	1 to 20000	ms	○	Wait for the next step until the set time elapses.								
ZRT	Home position return	ZRT				Perform a home position return.								
TIMES	Number of program executions command	TIMES (Setting value)	0, 1 to 10000	times	○	Position a "TIMES (Setting value)" command at the start of the program, and set the number of program executions. To execute the program only one time, no setting is required. Setting "0" repeats the operation endlessly.								
STOP	Program stop	STOP				<p>Stop the running program. Make sure to describe this command in the final row.</p>								

5. HOW TO USE THE PROGRAM

Command	Name	Setting	Setting range	Unit	Indirect specification (Note 7)	Description
TLP (Note 8)	Forward rotation torque limit	TLP (Setting value)	0, 1 to 1000	0.1 %	/	Using the maximum torque as 100%, limit the generated torque of the servo motor in the CCW power running or CW regeneration. The setting value is valid until the program stops. Specifying the setting value to "0" enables the [Pr. PA11] setting.
TLN (Note 8)	Reverse rotation torque limit	TLN (Setting value)	0, 1 to 1000	0.1 %		Using the maximum torque as 100%, limit the generated torque of the servo motor in the CW power running or CCW regeneration. The setting value is valid until the program stops. Specifying the setting value to "0" enables the [Pr. PA12] setting.
TQL (Note 8)	Torque limit	TQL (Setting value)	0, 1 to 1000	0.1 %		Using the maximum torque as 100%, limit the generated torque of the servo motor. The setting value is valid until the program stops. Specifying the setting value to "0" enables the [Pr. PA11] and [Pr. PA12] settings.

- Note
1. The "SYNC", "OUTON", "OUTOF", "TRIP", "TRIP1", "COUNT", "LPOS", and "ITP" commands are valid even during a command output.
 2. The "SPN" command is valid while the "MOV", "MOVA", "MOVI", or "MOVIA" command is executed. The "STA", "STB", "STC", and "STD" commands are valid while the "MOV" or "MOVI" command is executed.
 3. When the on time is set using [Pr. PT23] to [Pr. PT25], the next command is executed after the set time elapses.
 4. When the remaining distance is the set value or less, or while the servo motor stops or decelerates, the program skips the "ITP" command and proceeds to the next step.
 5. The parameter value is valid normally. However, the value set for the command is valid after the command is executed until the program stops.
 6. The unit of the position command data input can be changed with [Pr. PT01]. For the setting range for each unit, refer to section 5.2.3 (1) (a).
 7. For the explanation of the indirect specification, refer to section 5.2.2 (2) (j).
 8. The parameter value is valid normally. However, the value set for the command is valid after the command is executed until the program stops.
 9. The unit will be "mm/s" for the linear servo motor control mode.

(2) Detailed explanations of commands

(a) Positioning conditions (SPN/STA/STB/STC/STD)

POINT
<ul style="list-style-type: none"> ● Once values are set for the "SPN", "STA", "STB" and "STC" commands, the values are valid without resetting them. (The values are not initialized at the program startup.) The settings are valid in the other programs. ● The value set for the "STD" command is valid in the same program only. The value is initialized to the setting value of [Pr. PC03] at the program startup, and therefore the value is invalid in the other programs.

The "SPN", "STA", "STB", "STC", and "STD" commands are valid while the "MOV" or "MOVA" command is executed.

5. HOW TO USE THE PROGRAM

1) Program example 1

When executing two operations where the servo motor speeds, acceleration time constants, and deceleration time constants are the same and the travel commands are different

Command	Description		
SPN (1000)	Servo motor speed	1000 [r/min]	a)
STA (200)	Acceleration time constant	200 [ms]	b)
STB (300)	Deceleration time constant	300 [ms]	c)
MOV (1000)	Absolute value travel command	1000 [$\times 10^{\text{STM}}$ μm]	d)
TIM (100)	Dwell	100 [ms]	e)
MOV (2000)	Absolute value travel command	2000 [$\times 10^{\text{STM}}$ μm]	f)
STOP	Program stop		

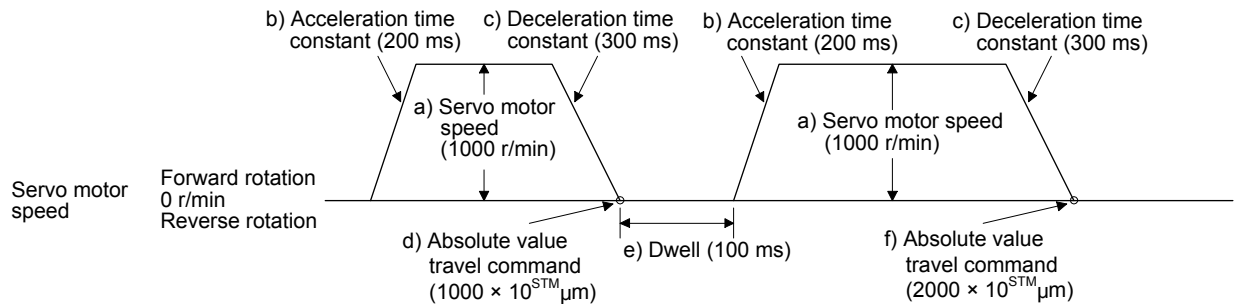

2) Program example 2

When executing two operations where the servo motor speeds, acceleration time constants, deceleration time constants, and travel commands are different

Command	Description		
SPN (1000)	Servo motor speed	1000 [r/min]	a)
STA (200)	Acceleration time constant	200 [ms]	b)
STB (300)	Deceleration time constant	300 [ms]	c)
MOV (1000)	Absolute value travel command	1000 [$\times 10^{\text{STM}}$ μm]	d)
TIM (100)	Dwell	100 [ms]	e)
SPN (500)	Servo motor speed	500 [r/min]	f)
STC (200)	Acceleration/deceleration time constant	200 [ms]	g)
MOV (1500)	Absolute value travel command	1500 [$\times 10^{\text{STM}}$ μm]	h)
STOP	Program stop		

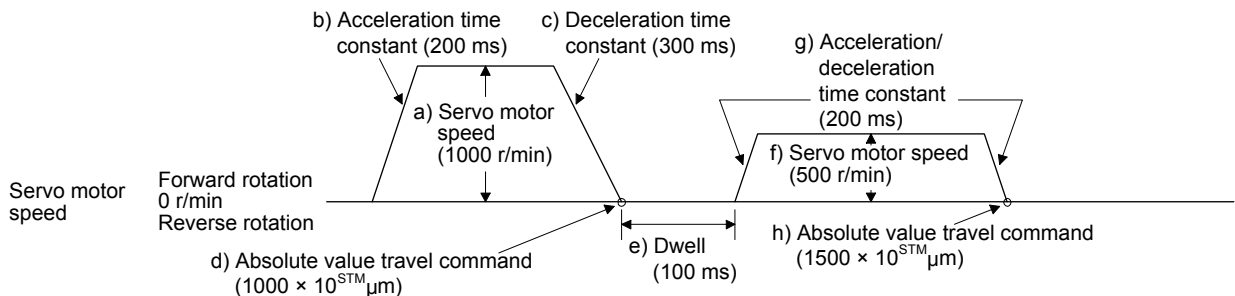

5. HOW TO USE THE PROGRAM

3) Program example 3

Using the S-pattern acceleration/deceleration time constants reduces abrupt movements at acceleration or deceleration. When the "STD" command is used, [Pr. PC03 S-pattern acceleration/deceleration time constant] does not function.

Command	Description
SPN (1000)	Servo motor speed 1000 [r/min] a)
STC (100)	Acceleration/deceleration time constant 1000 [ms] b)
STD (10)	S-pattern acceleration/deceleration time constant 10 [ms] c)
MOV (2000)	Absolute value travel command 2000 [$\times 10^{\text{STM}}$ μm] d)
STOP	Program stop

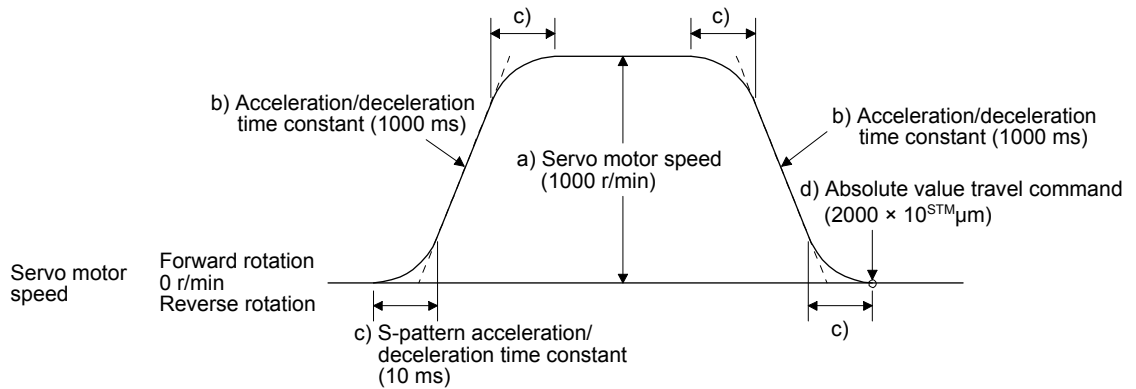

5. HOW TO USE THE PROGRAM

(b) Continuous travel commands (MOVA/MOVIA)

POINT
<p>● You cannot use a combination of "MOV" and "MOVIA" commands and a combination of "MOVI" and "MOVA" commands.</p>

The "MOVA" command is a continuous travel command against the "MOV" command. Upon executing the travel command by the "MOV" command, the travel command by the "MOVA" command is executed continuously without a stop.

The varying speed point under the "MOVA" command is at the deceleration start position of the operation by the preceding "MOV" or "MOVA" command.

The acceleration/deceleration time constants of the "MOVA" command are set to the values at the execution of the preceding "MOV" command.

The "MOVIA" command is a continuous travel command against the "MOVI" command. Upon executing the travel command by the "MOVI" command, the travel command by the "MOVIA" command is executed continuously without a stop.

The varying speed point under the "MOVIA" command is at the deceleration start position of the operation by the preceding "MOVI" or "MOVIA" command.

The acceleration/deceleration time constants of the "MOVIA" command are set to the values at the execution of the preceding "MOVI" command.

Command	Name	Setting	Unit	Description
MOV	Absolute value travel command	MOV (Setting value)	$\times 10^{\text{STM}} \mu\text{m}$	Absolute value travel command
MOVA	Absolute value continuous travel command	MOVA (Setting value)	$\times 10^{\text{STM}} \mu\text{m}$	Absolute value continuous travel command
MOVI	Incremental value travel command	MOVI (Setting value)	$\times 10^{\text{STM}} \mu\text{m}$	Incremental value travel command
MOVIA	Incremental value continuous travel command	MOVIA (Setting value)	$\times 10^{\text{STM}} \mu\text{m}$	Incremental value continuous travel command

5. HOW TO USE THE PROGRAM

1) Program example 1

When using the absolute value travel command under the absolute value command method

Command	Description		
SPN (500)	Servo motor speed	500 [r/min]	a)
STA (200)	Acceleration time constant	200 [ms]	b)
STB (300)	Deceleration time constant	300 [ms]	c)
MOV (500)	Absolute value travel command	500 [$\times 10^{\text{STM}} \mu\text{m}$]	d)
SPN (1000)	Servo motor speed	1000 [r/min]	e)
MOVA (1000)	Absolute value continuous travel command	1000 [$\times 10^{\text{STM}} \mu\text{m}$]	f)
MOVA (0)	Absolute value continuous travel command	0 [$\times 10^{\text{STM}} \mu\text{m}$]	g)
STOP	Program stop		

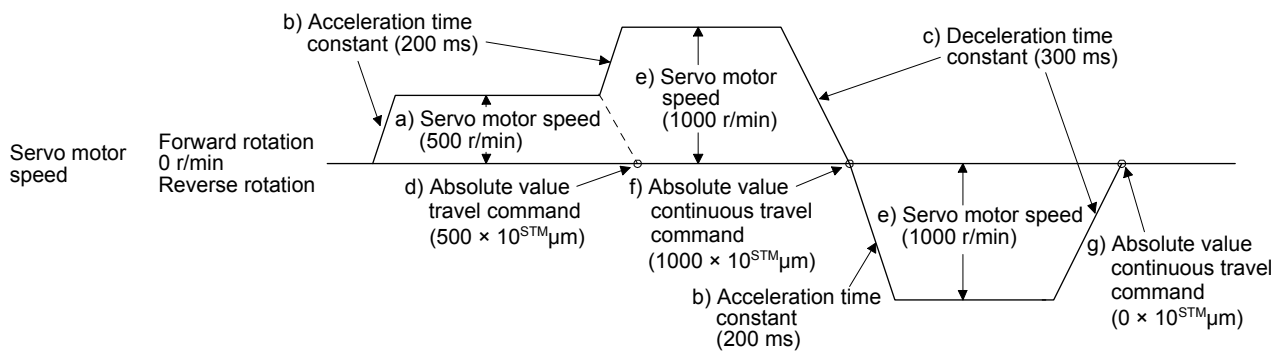

5. HOW TO USE THE PROGRAM

2) Program example 2 (Incorrect usage)

For continuous operations, the acceleration time constant and the deceleration time constant cannot be changed at each change of the servo motor speed. Therefore, even if you insert an "STA", "STB", or "STD" command at a speed change, the command is invalid.

Command	Description
SPN (500)	Servo motor speed 500 [r/min] a)
STA (200)	Acceleration time constant 200 [ms] b)
STB (300)	Deceleration time constant 300 [ms] c)
MOV (500)	Absolute value travel command $500 [\times 10^{\text{STM}} \mu\text{m}]$ d)
SPN (1000)	Servo motor speed 1000 [r/min] e)
STC (500)	Acceleration/deceleration time constant 500 [ms] f) Disabled
MOVA (1000)	Absolute value continuous travel command $1000 [\times 10^{\text{STM}} \mu\text{m}]$ g)
SPN (1500)	Servo motor speed 1500 [r/min] h)
STC (100)	Acceleration/deceleration time constant 100 [ms] i) Disabled
MOVA (0)	Absolute value continuous travel command $0 [\times 10^{\text{STM}} \mu\text{m}]$ j)
STOP	Program stop

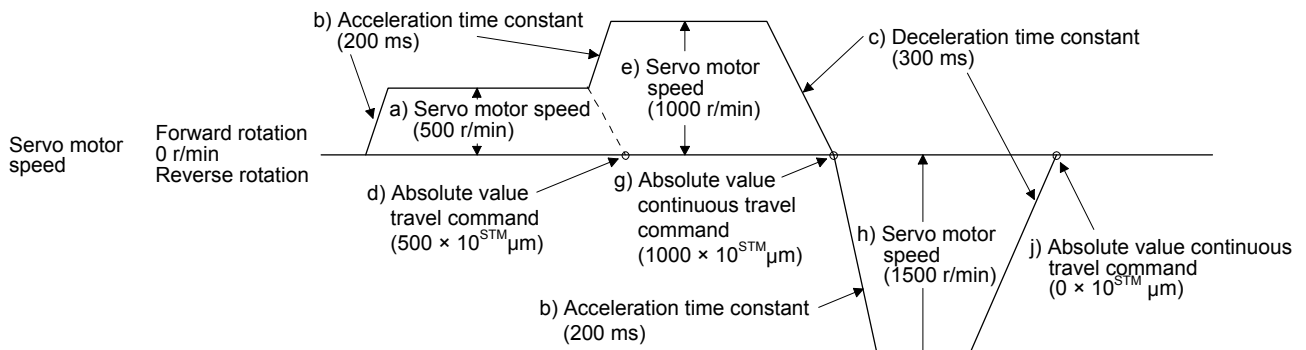

5. HOW TO USE THE PROGRAM

(c) Input/output commands (OUTON/OUTOF) and trip point commands (TRIP/TRIPI)

POINT
<ul style="list-style-type: none"> ● Using [Pr. PT23] to [Pr. PT25], you can set the time until OUT1 (Program output 1) to OUT3 (Program output 3) are switched off. The commands are switched off under the following conditions. <ul style="list-style-type: none"> ▪ The commands are switched off by the OUTOF command. ▪ The commands are switched off by a program stop. ● The "TRIP" and "TRIPI" commands have the following restrictions. <ul style="list-style-type: none"> ▪ The "MOV" or "MOVA" command cannot be used in combination with the "TRIPI" command. ▪ The "MOVI" or "MOVIA" command cannot be used in combination with the "TRIP" command. ▪ The "TRIP" and "TRIPI" commands do not execute the next step until the servo motor passes the set address or travel distance. Set the commands within the travel command range. ▪ Determine whether the servo motor has passed the set address or travel distance by checking the actual position (for each command). Additionally, determine whether the servo motor has passed the set address or travel distance by checking both edges of the address increasing/decreasing directions.

1) Program example 1

OUT1 (Program output 1) is switched on upon a program execution. When the program ends, OUT1 (Program output 1) is switched off.

Command	Description
SPN (1000)	Servo motor speed 1000 [r/min]
STA (200)	Acceleration time constant 200 [ms]
STB (300)	Deceleration time constant 300 [ms]
MOV (500)	Absolute value travel command 500 [$\times 10^{\text{STM}}$ μm]
OUTON (1)	Switch on OUT1 (Program output 1). a)
TIM (100)	Dwell 100 [ms]
MOV (250)	Absolute value travel command 250 [$\times 10^{\text{STM}}$ μm]
TIM (50)	Dwell 50 [ms]
STOP	Program stop b)

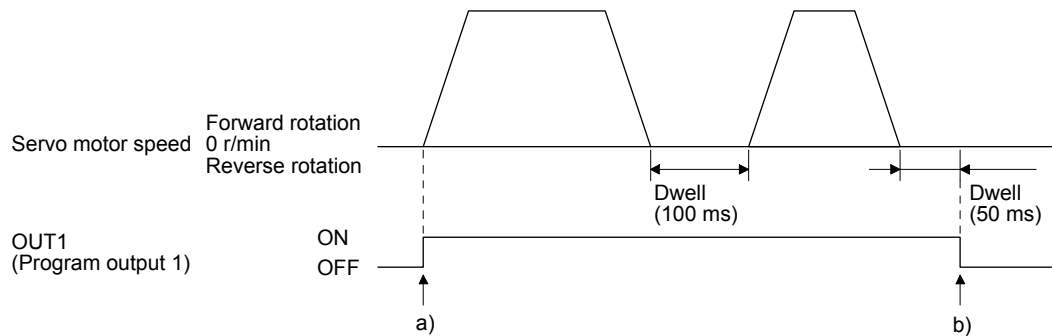

5. HOW TO USE THE PROGRAM

2) Program example 2

Using [Pr. PT23] to [Pr. PT25], you can switch off OUT1 (Program output 1) to OUT3 (Program output 3) automatically.

Parameter	Name	Setting value	Description
Pr. PT23	OUT1 output setting time	20	Switch off OUT1 200 [ms] later. a)
Pr. PT24	OUT2 output setting time	10	Switch off OUT2 100 [ms] later. b)
Pr. PT25	OUT3 output setting time	50	Switch off OUT3 500 [ms] later. c)

Command	Description
SPN (500)	Servo motor speed 500 [r/min]
STA (200)	Acceleration time constant 200 [ms]
STB (300)	Deceleration time constant 300 [ms]
MOV (1000)	Absolute value travel command 1000 [$\times 10^{\text{STM}}$ μm]
OUTON (1)	Switch on OUT1 (Program output 1).
OUTON (2)	Switch on OUT2 (Program output 2).
OUTON (3)	Switch on OUT3 (Program output 3).
STOP	Program stop

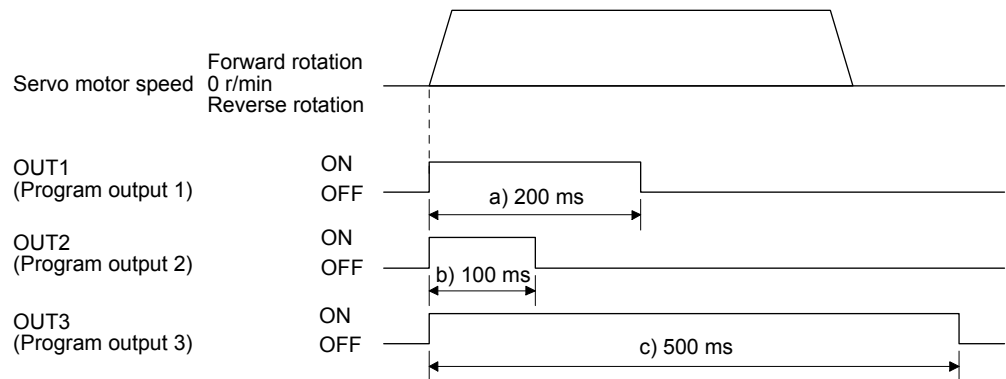

5. HOW TO USE THE PROGRAM

3) Program example 3

When setting the position address where the "OUTON" or "OUTOF" command is executed by using the "TRIP" or "TRIPi" command

Command	Description		
SPN (1000)	Servo motor speed	1000 [r/min]	
STA (200)	Acceleration time constant	200 [ms]	
STB (300)	Deceleration time constant	300 [ms]	
MOV (500)	Absolute value travel command	500 [$\times 10^{\text{STM}} \mu\text{m}$]	
TRIP (250)	Absolute value trip point specification	250 [$\times 10^{\text{STM}} \mu\text{m}$]	a)
OUTON (2)	Switch on OUT2 (Program output 2).		b)
TRIP (400)	Absolute value trip point specification	400 [$\times 10^{\text{STM}} \mu\text{m}$]	c)
OUTOF (2)	Switch off OUT2 (Program output 2).		d)
TIM (100)	Dwell	100 [ms]	
MOVI (500)	Incremental value travel command	500 [$\times 10^{\text{STM}} \mu\text{m}$]	
TRIPi (300)	Incremental value trip point specification	300 [$\times 10^{\text{STM}} \mu\text{m}$]	e)
OUTON (2)	Switch on OUT2 (Program output 2).		f)
STOP	Program stop		g)

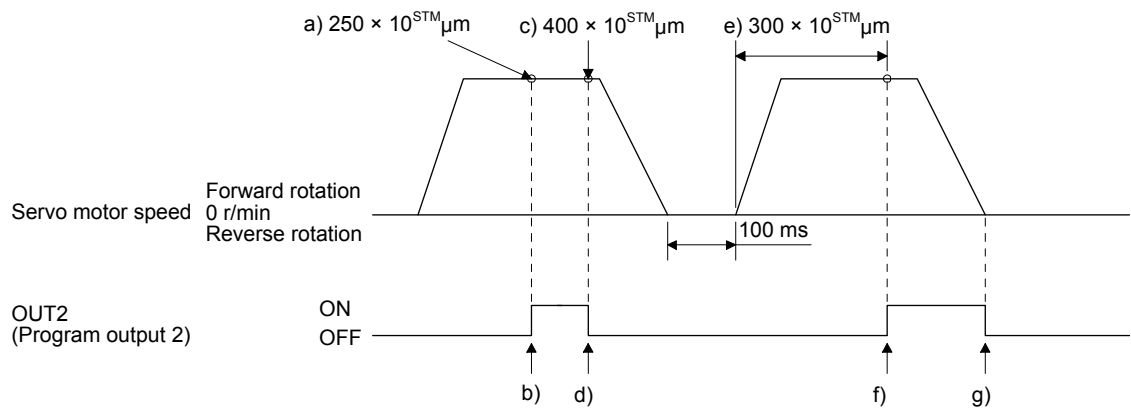

5. HOW TO USE THE PROGRAM

4) Program example 4

Command	Description		
SPN (500)	Servo motor speed	500 [r/min]	
STA (200)	Acceleration time constant	200 [ms]	
STB (300)	Deceleration time constant	300 [ms]	
MOVI (600)	Incremental value travel command	$600 \times 10^{\text{STM}} \mu\text{m}$	a)
TRIP1 (300)	Incremental value trip point specification	$300 \times 10^{\text{STM}} \mu\text{m}$	b)
OUTON (3)	Switch on OUT3 (Program output 3).		c)
SPN (700)	Servo motor speed	700 [r/min]	
MOVIA (700)	Incremental value continuous travel command	$700 \times 10^{\text{STM}} \mu\text{m}$	d)
TRIP1 (300)	Incremental value trip point specification	$300 \times 10^{\text{STM}} \mu\text{m}$	e)
OUTOF (3)	Switch off OUT3 (Program output 3).		f)
STOP	Program stop		

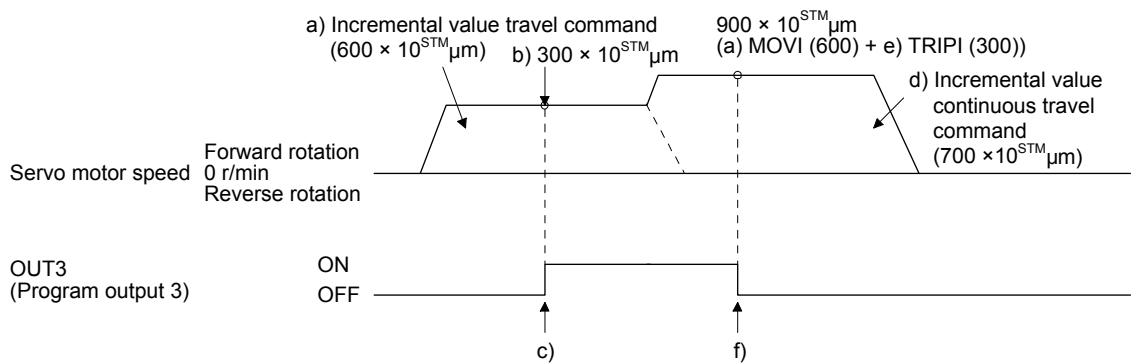

(d) Dwell (TIM)

Using the "TIM (setting value)" command, set the time from when the remaining distance under the command is "0" until when the next step is executed.

The following shows operation examples of using this command in combination with the other commands for reference.

1) Program example 1

Command	Description		
TIM (200)	Dwell	200 [ms]	a)
SPN (1000)	Servo motor speed	1000 [r/min]	
STC (20)	Acceleration/deceleration time constant	20 [ms]	
MOV (1000)	Absolute value travel command	$1000 \times 10^{\text{STM}} \mu\text{m}$	
STOP	Program stop		

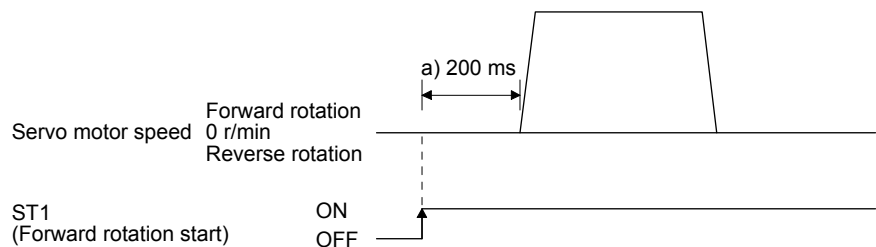

5. HOW TO USE THE PROGRAM

2) Program example 2

Command	Description	
SPN (1000)	Servo motor speed	1000 [r/min]
STC (20)	Acceleration/deceleration time constant	20 [ms]
MOVI (1000)	Incremental value travel command	1000 [$\times 10^{\text{STM}}$ μm]
TIM (200)	Dwell	200 [ms] a)
OUTON (1)	Switch on OUT1 (Program output 1).	b)
MOVI (500)	Incremental value travel command	500 [$\times 10^{\text{STM}}$ μm]
STOP	Program stop	

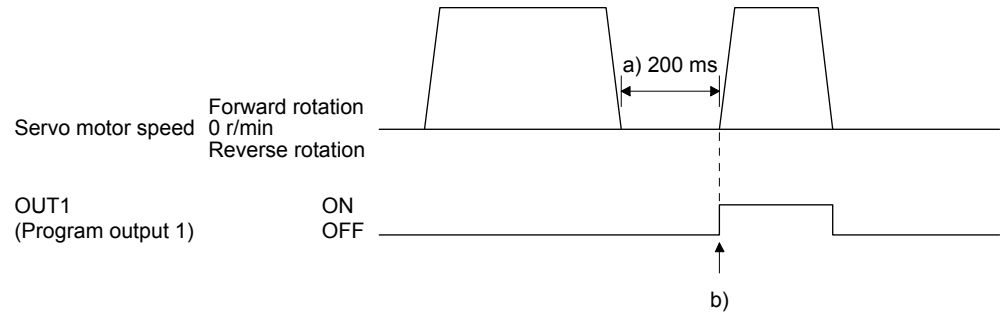

3) Program example 3

Command	Description	
SPN (1000)	Servo motor speed	1000 [r/min]
STC (20)	Acceleration/deceleration time constant	20 [ms]
MOVI (1000)	Incremental value travel command	1000 [$\times 10^{\text{STM}}$ μm]
OUTON (1)	Switch on OUT1 (Program output 1).	a)
TIM (200)	Dwell	200 [ms] b)
MOVI (500)	Incremental value travel command	500 [$\times 10^{\text{STM}}$ μm]
STOP	Program stop	

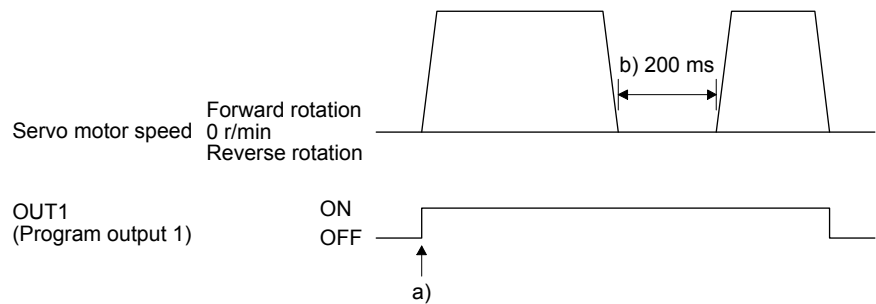

5. HOW TO USE THE PROGRAM

4) Program example 4

Command	Description	
SPN (1000)	Servo motor speed	1000 [r/min]
STC (20)	Acceleration/deceleration time constant	20 [ms]
MOVI (1000)	Incremental value travel command	1000 [$\times 10^{\text{STM}}$ μm]
TIM (200)	Dwell	200 [ms] a)
OUTON (1)	Switch on OUT1 (Program output 1).	b)
TIM (300)	Dwell	300 [ms] c)
MOVI (500)	Incremental value travel command	500 [$\times 10^{\text{STM}}$ μm]
STOP	Program stop	

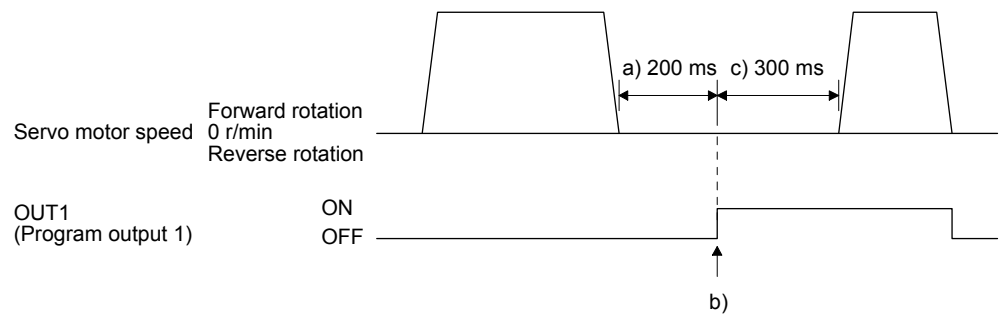

5) Program example 5

Command	Description	
SPN (1000)	Servo motor speed	1000 [r/min]
STC (20)	Acceleration/deceleration time constant	20 [ms]
MOVI (1000)	Incremental value travel command	1000 [$\times 10^{\text{STM}}$ μm]
TIM (200)	Dwell	200 [ms] a)
SYNC (1)	Suspend the step until PI1 (Program input 1) is switched on.	
MOVI (500)	Incremental value travel command	500 [$\times 10^{\text{STM}}$ μm]
STOP	Program stop	

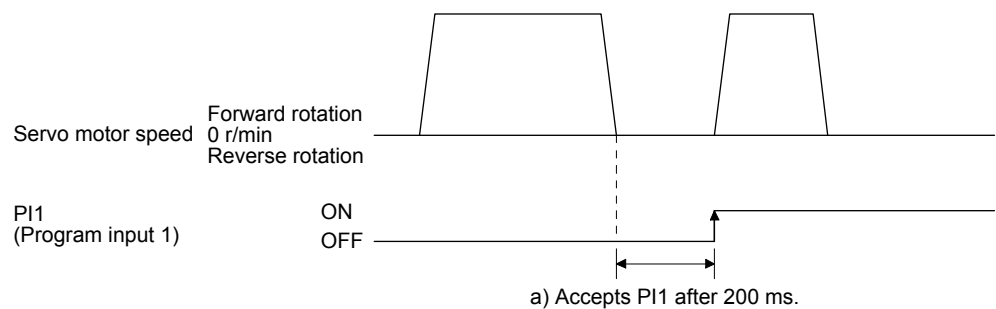

5. HOW TO USE THE PROGRAM

6) Program example 6

Command	Description
SPN (1000)	Servo motor speed 1000 [r/min]
STC (20)	Acceleration/deceleration time constant 20 [ms]
MOVI (1000)	Incremental value travel command 1000 [$\times 10^{\text{STM}}$ μm]
SYNC (1)	Suspend the step until PI1 (Program input 1) is switched on.
TIM (200)	Dwell 200 [ms] a)
MOVI (500)	Incremental value travel command 500 [$\times 10^{\text{STM}}$ μm]
STOP	Program stop

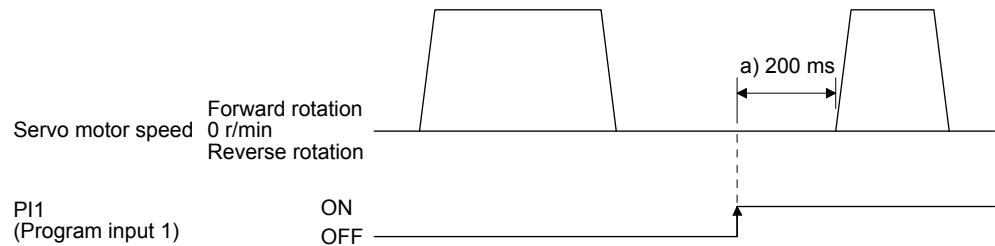

(e) Interrupt positioning (ITP)

POINT
<ul style="list-style-type: none"> ● For positioning with the "ITP" command, the stop position varies depending on the servo motor speed when the "ITP" command becomes enabled. ● In the following cases, the program does not execute the "ITP" command and proceeds to the next step. <ul style="list-style-type: none"> ▪ When the setting value of the "ITP" command is smaller than that of the travel command set by the "MOV", "MOVI", or "MOVA" command ▪ When the remaining distance under the "ITP" command is equal to or less than the travel distance under the "ITP" command ▪ While the servo motor decelerates

When an "ITP" command is used in the program, starting from the position where PI1 (Program input 1) to PI3 (Program input 3) are switched on, the servo motor rotates a distance of the set value and stops.

When using the "ITP" command, make sure to position the command preceding a "SYNC" command.

5. HOW TO USE THE PROGRAM

1) Program example 1

Command	Description
SPN (500)	Servo motor speed 500 [r/min]
STA (200)	Acceleration time constant 200 [ms]
STB (300)	Deceleration time constant 300 [ms]
MOV (600)	Absolute value travel command 600 [$\times 10^{\text{STM}}$ μm]
SPN (100)	Servo motor speed 100 [r/min]
MOVA (600)	Continuous travel command 600 [$\times 10^{\text{STM}}$ μm]
SYNC (1)	Suspend the step until PI1 (Program input 1) is switched on. a)
ITP (200)	Interrupt positioning 200 [$\times 10^{\text{STM}}$ μm] b)
STOP	Program stop

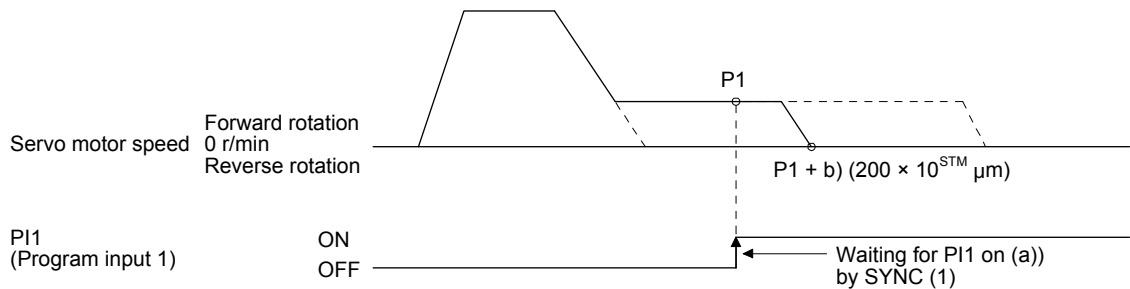

2) Program example 2

When the travel distance set by the "ITP" command is smaller than the travel distance required for deceleration, the actual deceleration time constant becomes smaller than the setting value of the "STB" command.

Command	Description
SPN (500)	Servo motor speed 500 [r/min]
STA (200)	Acceleration time constant 200 [ms]
STB (300)	Deceleration time constant 300 [ms]
MOV (1000)	Absolute value travel command 1000 [$\times 10^{\text{STM}}$ μm]
SYNC (1)	Suspend the step until PI1 (Program input 1) is switched on. a)
ITP (50)	Interrupt positioning 50 [$\times 10^{\text{STM}}$ μm] b)
STOP	Program stop

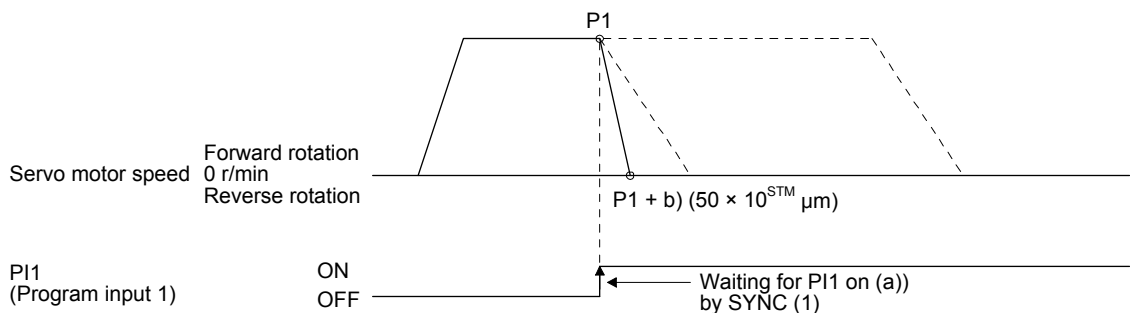

5. HOW TO USE THE PROGRAM

(f) External pulse count (COUNT)

When the number of input pulses of the manual pulse generator becomes larger than the value set for the "COUNT" command, the next step is executed. Setting "0" clears cumulative input pulses.

Command	Description
COUNT (500)	Wait for the next step until the number of input pulses of the manual pulse generator reaches 500 [pulse]. a)
SPN (500)	Servo motor speed 500 [r/min]
STA (200)	Acceleration time constant 200 [ms]
STB (300)	Deceleration time constant 300 [ms]
MOV (1000)	Absolute value travel command 1000 [$\times 10^{\text{STM}}$ μm]
TRIP (500)	Trip point specification 500 [$\times 10^{\text{STM}}$ μm] b)
COUNT (0)	Clear cumulative input pulses. c)
STOP	Program stop

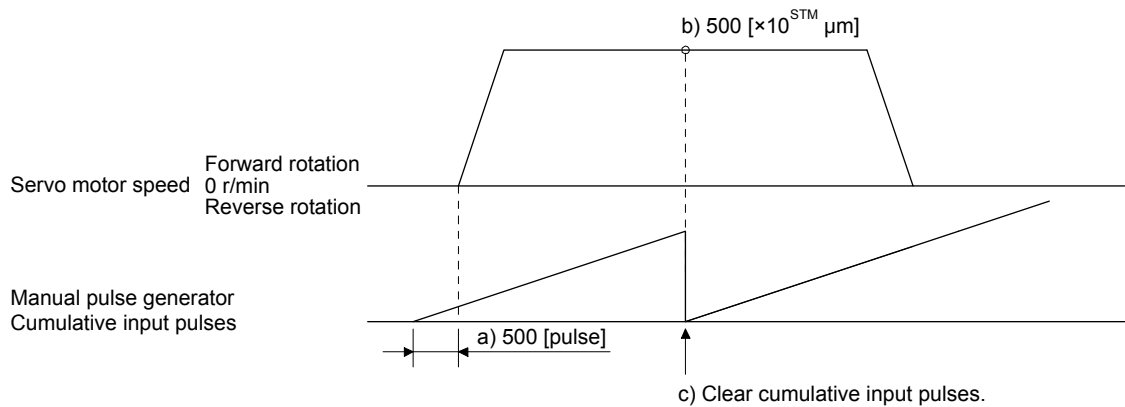

5. HOW TO USE THE PROGRAM

(g) Step repeat instruction (FOR...NEXT)

POINT
● You cannot insert "FOR...NEXT" commands between a "FOR" command and a "NEXT" command.

The steps between the "FOR (Setting value)" and the "NEXT" commands are repeated for the set number of times. Setting "0" repeats the operation endlessly.

For how to stop the program in this status, refer to section 5.2.4 (4).

Command	Description
SPN (1000)	Servo motor speed 1000 [r/min]
STC (20)	Acceleration/deceleration time constant 20 [ms]
MOV (1000)	Absolute value travel command 1000 [$\times 10^{\text{STM}}$ μm]
TIM (100)	Dwell 100 [ms]
FOR (3)	Start of step repeat instruction 3 [time] a)
MOVI (100)	Incremental value travel command 100 [$\times 10^{\text{STM}}$ μm] b)
TIM (100)	Dwell 100 [ms]
NEXT	End of step repeat instruction c)
FOR (2)	Start of step repeat instruction 2 [time] d)
MOVI (200)	Incremental value travel command 200 [$\times 10^{\text{STM}}$ μm] e)
TIM (100)	Dwell 100 [ms]
NEXT	End of step repeat instruction f)
STOP	Program stop

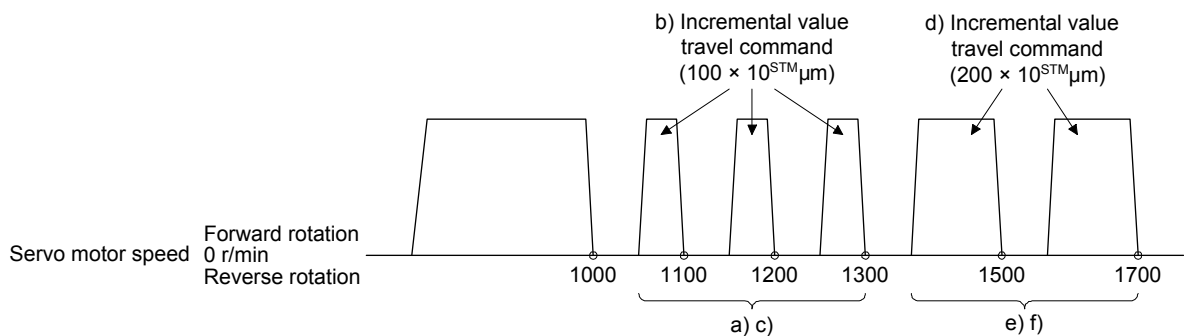

5. HOW TO USE THE PROGRAM

(h) Number of program executions command (TIMES)

By setting the number of program executions for the "TIMES (Setting value)" command, which is positioned at the start of the program, you can repeat the execution of the program. To execute the program one time, the "TIMES" command is not required. Setting "0" repeats the operation endlessly. For how to stop the program in this status, refer to section 5.2.4 (4).

Command	Description
TIMES (2)	Number of program executions command 2 [time] a)
SPN (1000)	Servo motor speed 1000 [r/min]
STC (20)	Acceleration/deceleration time constant 20 [ms]
MOVI (1000)	Incremental value travel command 1000 [$\times 10^{\text{STM}}$ μm] b)
TIM (100)	Dwell 100 [ms]
STOP	Program stop

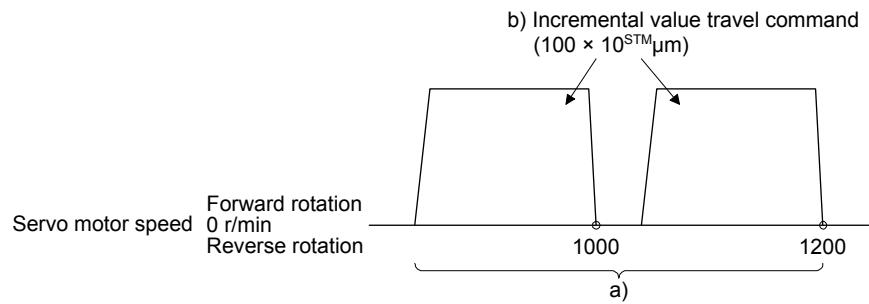

5. HOW TO USE THE PROGRAM

(i) Current position latch (LPOS)

POINT
<ul style="list-style-type: none"> ● When the current position is stored using LPS (Current position latch input), the value varies depending on the servo motor speed at switch-on of LPS. ● The program does not proceed to the next step until LPS (Current position latch input) is switched on. ● The stored data is not cleared without power-off of the servo amplifier. ● After the input of LPS (Current position latch input) becomes valid by the "LPOS" command, the input is cleared in the following conditions. <ul style="list-style-type: none"> ▪ When the rising edge of LPS (Current position latch input) is detected ▪ When the program ends ▪ When the operation mode is changed ▪ When the servo motor forcibly stops ▪ When an alarm occurs ▪ When the servo motor enters the servo-off status

The current position at switch-on of LPS (Current position latch input) is stored. The stored position data can be read with the communication function.

The current position latch function, which is set during the execution of the program, is reset when the program ends. The function is also reset at an operation mode change, forced stop, alarm occurrence, or servo-off. The function is not reset at a temporary stop only.

Command	Description
SPN (500)	Servo motor speed 500 [r/min]
STA (200)	Acceleration time constant 200 [ms]
STB (300)	Deceleration time constant 300 [ms]
MOV (1000)	Absolute value travel command 1000 [$\times 10^{\text{STM}}$ μm]
LPOS	Set a current position latch. a)
STOP	Program stop

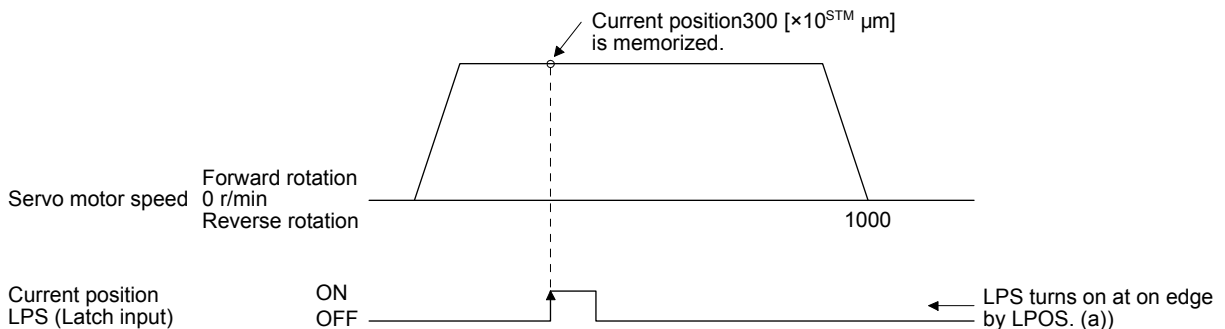

5. HOW TO USE THE PROGRAM

(j) Indirect specification with general purpose registers (R1 to R4, D1 to D4)

You can indirectly specify the setting values of the "SPN", "STA", "STB", "STC", "STD", "MOV", "MOVI", "MOVA", "MOVIA", "TIM", and "TIMES" commands.

The value, which is stored in each general purpose register (R1 to R4, D1 to D4), is used as the setting value of each command.

While the program is not executed by a communication command, you can change the general purpose registers by using MR Configurator2 or a communication command.

The data of the general purpose registers is erased at power-off of the servo amplifier. Note that you can store the data of the general purpose registers (R1 to R4) in EEPROM.

The setting range of each general purpose register is that of the instruction for which each register is used.

The following explains a case where the general purpose registers are set as shown below before the execution of the program.

General purpose register	Setting
R1	1000
R2	2000
D1	200
D2	300

Command	Description
SPN (1000)	Servo motor speed 1000 [r/min] a)
STA (D1)	Acceleration time constant D1 = 200 [ms] b)
STB (D2)	Deceleration time constant D2 = 300 [ms] c)
MOVI (R1)	Incremental value travel command R1 = 1000 [$\times 10^{\text{STM}}$ μm] d)
TIM (100)	Dwell 100 [ms] e)
MOVI (R2)	Incremental value travel command R2 = 2000 [$\times 10^{\text{STM}}$ μm] f)
STOP	Program stop

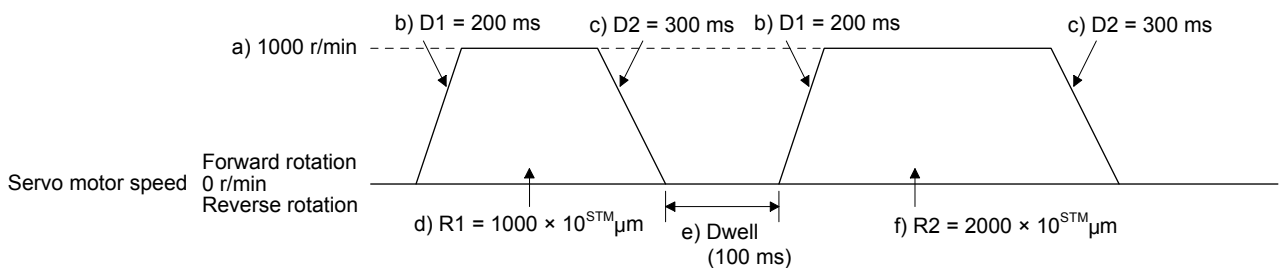

5. HOW TO USE THE PROGRAM

(k) Home position return command (ZRT)

Perform a home position return.

Set the home position with a parameter. (Refer to section 5.4.)

With the "ZRT" command, the program proceeds to the next step after the home position return completion.

POINT
<ul style="list-style-type: none"> ● If the home position return has not completed successfully, [AL. 96 Home position return incomplete warning] occurs. In this case, the program proceeds to the next step without a stop. Since the home position return is incomplete, the travel command is invalid. ● For precautions for using linear servo motors or fully closed loop system, refer to section 4.4.15 and 4.4.16.

Command	Description
SPN (500)	Servo motor speed 500 [r/min] a)
STA (200)	Acceleration time constant 200 [ms] b)
STB (300)	Deceleration time constant 300 [ms] c)
ZRT	Home position return d)
MOV (500)	Absolute value travel command 500 [$\times 10^{\text{STM}}$ μm] e)
STOP	Program stop

Item	Used parameter	Setting
Dog type home position return	[Pr. PT04]	"_ _ _ 0"
Home position return direction	[Pr. PT04]	"_ _ 0 _" (Address increasing direction)
Dog input polarity	[Pr. PT29]	"_ _ _ 1" (Detects dog when DOG (proximity dog) is on.)
Home position return speed	[Pr. PT05]	100 [r/min]
Creep speed	[Pr. PT06]	50 [r/min]
Home position shift distance	[Pr. PT07]	0 [$\times 10^{\text{STM}}$ μm]
Home position return acceleration time constant	[Pr. PC30]	100 [ms]
Home position return deceleration time constant	[Pr. PC31]	200 [ms]
Home position return position data	[Pr. PT08]	0

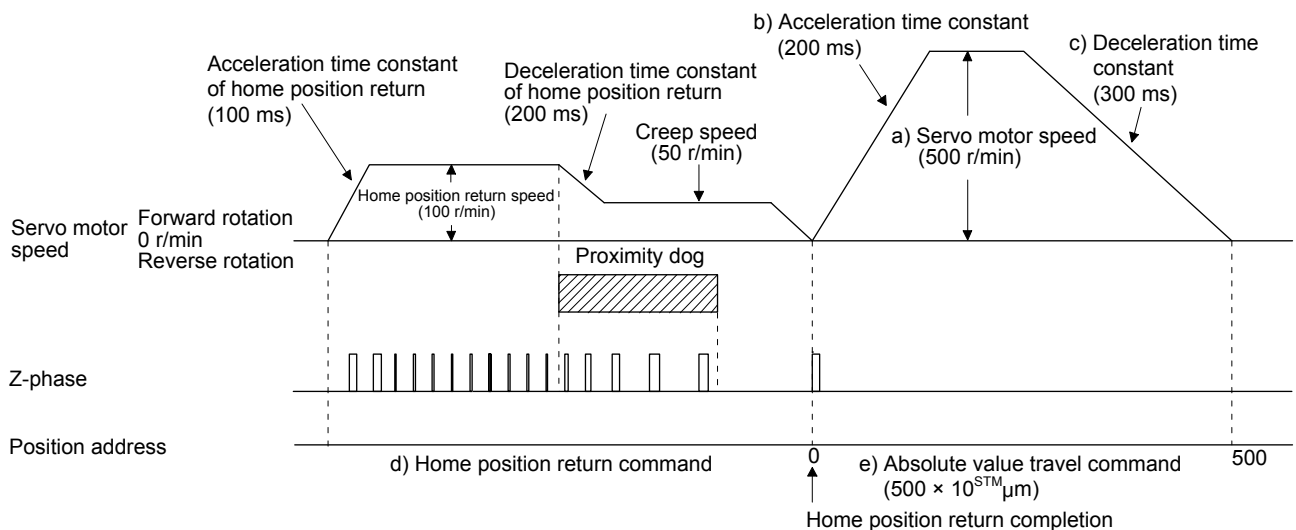

5. HOW TO USE THE PROGRAM

(I) Torque limit value switching (TLP/TLN/TQL)

Using the maximum torque as 100.0%, limit the generated torque of the servo motor.

1) Program example

Command	Description
SPN (1500)	Servo motor speed 1500 [r/min]
STA (100)	Acceleration time constant 100 [ms]
STB (200)	Deceleration time constant 200 [ms]
MOV (1000)	Absolute value travel command 1000 [$\times 10^{\text{STM}}$ μm]
SYNC (1)	Suspend the step until PI1 (Program input 1) is switched on. a)
TLP (800)	Forward rotation torque limit 800 [0.1%] b)
SYNC (2)	Suspend the step until PI2 (Program input 2) is switched on. c)
TLN (500)	Reverse rotation torque limit 500 [0.1%] d)
TIM (100)	Dwell 100 [ms] e)
MOV (500)	Absolute value travel command 1000 [$\times 10^{\text{STM}}$ μm]
SYNC (3)	Suspend the step until PI3 (Program input 3) is switched on. f)
TQL (300)	Torque limit 300 [0.1%] g)
STOP	Program stop h)

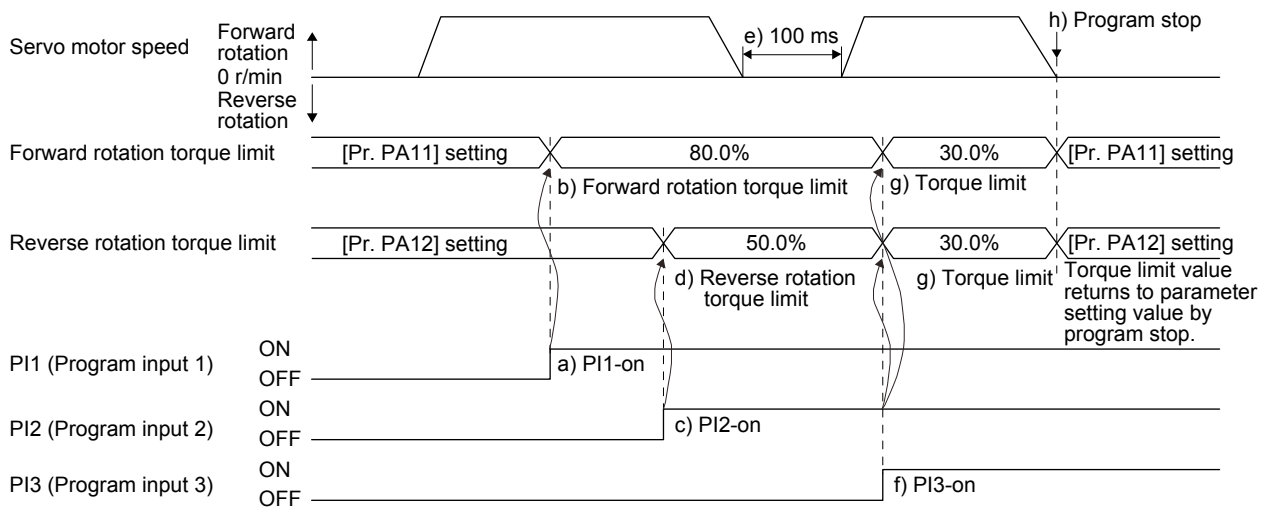

5. HOW TO USE THE PROGRAM

5.2.3 Basic settings of signals and parameters

(1) Parameter

(a) Setting range of the position data

The following shows the setting of [Pr. PA01].

Command method	Travel command	[Pr. PT01]		Position data input range		
		Positioning command method	Position data unit			
Absolute value command method	Absolute value travel command ("MOV", "MOVA")	--- 0	_ 0 _ _	[mm]	-999999 to 999999 [$\times 10^{\text{STM}}$ μm]	
			_ 1 _ _	[inch]	-999999 to 999999 [$\times 10^{\text{STM-4}}$ inch]	
			_ 2 _ _	[degree]	-360.000 to 360.000	
	_ 3 _ _		[pulse]	-999999 to 999999		
	Incremental value travel command ("MOVI", "MOVIA")		Incremental value travel command ("MOVI", "MOVIA")	_ 0 _ _	[mm]	-999999 to 999999 [$\times 10^{\text{STM}}$ μm]
				_ 1 _ _	[inch]	-999999 to 999999 [$\times 10^{\text{STM-4}}$ inch]
_ 2 _ _		[degree]		-999.999 to 999.999		
Incremental value command method	Incremental value travel command ("MOVI", "MOVIA")	--- 1	_ 3 _ _	[pulse]	-999999 to 999999	
			_ 0 _ _	[mm]	-999999 to 999999 [$\times 10^{\text{STM}}$ μm]	
			_ 1 _ _	[inch]	-999999 to 999999 [$\times 10^{\text{STM-4}}$ inch]	
			_ 2 _ _	[degree]	-999.999 to 999.999	
			_ 3 _ _	[pulse]	-999999 to 999999	

(b) Rotation direction selection/travel direction selection ([Pr. PA14])

Select the servo motor rotation direction when ST1 (Forward rotation start) is switched on.

[Pr. PA14] setting	Servo motor rotation direction when ST1 (Forward rotation start) is switched on
0 (Initial value)	CCW rotation with + position data CW rotation with - position data
1	CW rotation with + position data CCW rotation with - position data

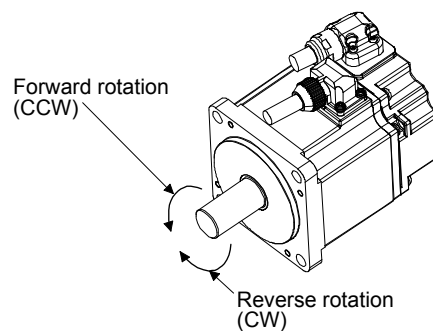

5. HOW TO USE THE PROGRAM

(c) Feed length multiplication ([Pr. PT03])

Set the feed length multiplication factor (STM) of the position data.

[Pr. PT03] setting	Position data input range			
	[mm]	[inch]	[degree] (Note)	[pulse] (Note)
___0 (Initial value)	-999.999 to 999.999	-99.9999 to 99.9999	-360.000 to 360.000	-999999 to 999999
___1	-9999.99 to 9999.99	-999.999 to 999.999		
___2	-99999.9 to 99999.9	-9999.99 to 9999.99		
___3	-999999 to 999999	-99999.9 to 99999.9		

Note. The feed length multiplication setting ([Pr. PT03]) is not applied to the unit multiplication factor. Adjust the unit multiplication factor in the electronic gear setting ([Pr. PA06] and [Pr. PA07]).

(2) Signal

Select a program with DI0 to DI7 and switch on ST1 to perform the positioning operation according to the set program. At this time, ST2 (Reverse rotation start) is invalid.

Item	Used device	Setting
Program operation method selection	MD0 (Operation mode selection 1)	Switch on MD0.
Program selection	DI0 (Program No. selection 1) DI1 (Program No. selection 2) DI2 (Program No. selection 3) DI3 (Program No. selection 4) DI4 (Program No. selection 5) DI5 (Program No. selection 6) DI6 (Program No. selection 7) DI7 (Program No. selection 8)	Refer to section 2.3 (1).
Start	ST1 (Forward rotation start)	Switch on ST1 to execute the program operation.

5. HOW TO USE THE PROGRAM

5.2.4 Timing chart of the program operation

(1) Operation condition

The following shows a timing chart when the program below is executed after the home position return completion under the absolute value command method.

Program No.	Description		
SPN (1000)	Servo motor speed	1000 [r/min]	
STC (100)	Acceleration/deceleration time constant	100 [ms]	
MOV (5000)	Absolute value travel command	5000 [$\times 10^{\text{STM}}$ μm]	Travel command 1
SYNC (1)	Suspend the step until PI1 (Program input 1) is switched on.		
STC (50)	Acceleration/deceleration time constant	50 [ms]	
MOV (7500)	Absolute value travel command	7500 [$\times 10^{\text{STM}}$ μm]	Travel command 2
STOP	Program stop		

Program No.	Description		
SPN (1000)	Servo motor speed	1000 [r/min]	
STC (100)	Acceleration/deceleration time constant	100 [ms]	
MOV (2500)	Absolute value travel command	2500 [$\times 10^{\text{STM}}$ μm]	Travel command 3
SYNC (1)	Suspend the step until PI1 (Program input 1) is switched on.		
STC (50)	Acceleration/deceleration time constant	50 [ms]	
MOV (5000)	Absolute value travel command	5000 [$\times 10^{\text{STM}}$ μm]	Travel command 4
STOP	Program stop		

(2) Timing chart

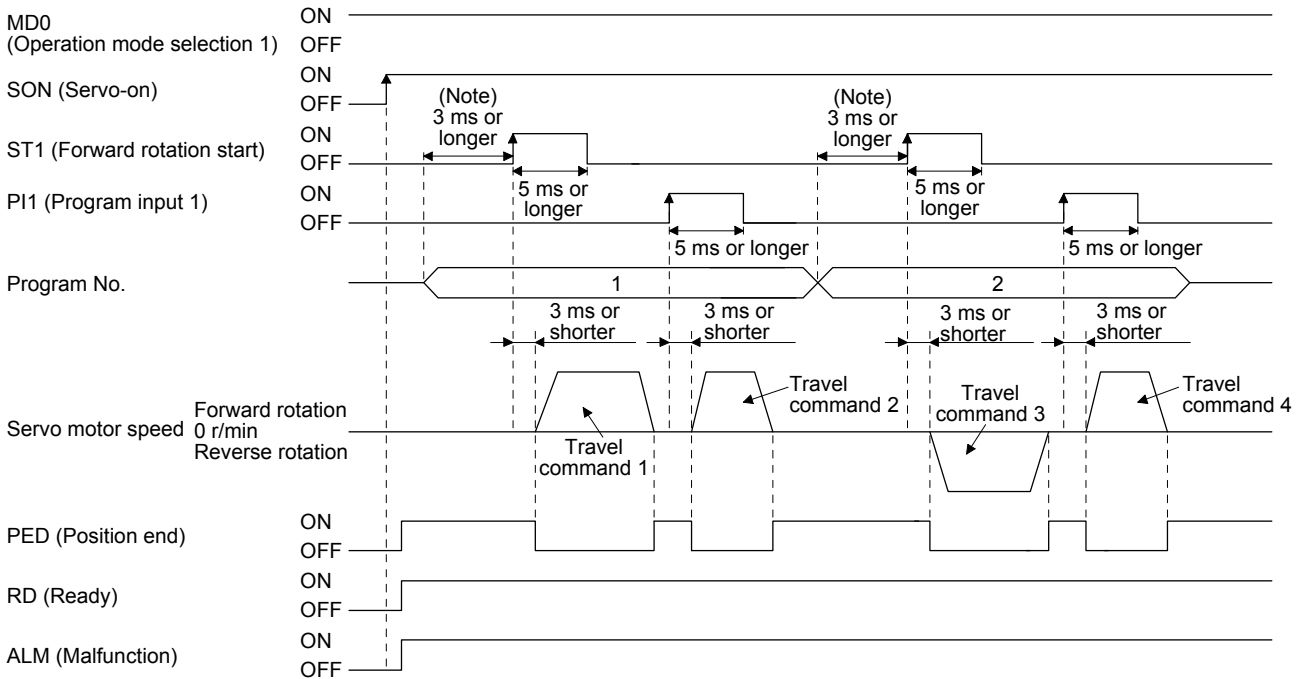

Note. The detection of external input signals is delayed by the set time in the input filter setting of [Pr. PD29]. Considering the output signal sequence from the controller and signal variations due to hardware, configure a sequence that changes the program selection earlier.

5. HOW TO USE THE PROGRAM

(3) Temporary stop/restart

When TSTP is switched on during the automatic operation, deceleration is performed using the deceleration time constant under the executing travel command to make a temporary stop. An operation for the remaining travel distance will be started by switching TSTP off and on (on-edge detection). This function will not operate even if ST1 (Forward rotation start) is switched on during the temporary stop. When the operation mode is changed from the automatic mode to the manual mode during the temporary stop, the remaining travel distance is cleared and the program ends. Switching on TSTP again will not restart the program. To start the program, switch on ST1 (Forward rotation start) again. The temporary stop/restart input does not function during a home position return or JOG operation. The timing chart is the same as that of the point table operation mode. Refer to 4.2.2 (3) (e).

(4) How to stop the program

To stop the executing program, switch on TSTP (Temporary stop/restart) to stop the positioning operation, and then switch on CR (Clear). At this time, the remaining distance under the command is cleared, and the program ends.

Switching on TSTP again will not restart the positioning operation.

To start the program, switch on ST1 (Forward rotation start) again.

(5) Program termination condition

The following shows the conditions for terminating the executing program.

Termination condition	Restart condition
Execution of STOP (Program stop)	Switch on ST1 (Forward rotation start). The program starts from the beginning.
When switching the automatic operation mode to the manual operation mode	After switching the mode to the automatic operation mode, switch on ST1. The program starts from the beginning.
When the hardware stroke limit is detected	After LSP and LSN are switched on, switch on ST1. The program starts from the beginning.
When the software stroke limit is detected ([Pr. PT15] to [Pr. PT18])	After the machine travels to the software stroke limit range, switch on ST1. The program starts from the beginning.
At base circuit shut-off	After resetting the base circuit shut-off, switch on ST1. The program starts from the beginning.

5. HOW TO USE THE PROGRAM

5.3 Manual operation mode

For the machine adjustment, home position adjustment, and others, you can shift the position to any position with a JOG operation or manual pulse generator.

5.3.1 JOG operation

(1) Setting

According to the purpose of use, set input signals and parameters as shown below. In this case, DI0 (Program No. selection 1) to DI7 (Program No. selection 8) are invalid.

Item	Used device/parameter	Setting
Manual operation mode selection	MD0 (Operation mode selection 1)	Switch off MD0.
Servo motor rotation direction	[Pr. PA14]	Refer to (2) of this section.
JOG speed	[Pr. PT13]	Set the servo motor speed.
Acceleration time constant	[Pr. PC01]	Set the acceleration time constant.
Deceleration time constant	[Pr. PC02]	Set the deceleration time constant.
S-pattern acceleration/deceleration time constant	[Pr. PC03]	Set the S-pattern acceleration/deceleration time constants.

(2) Servo motor rotation direction

[Pr. PA14] setting	Servo motor rotation direction	
	ST1 (Forward rotation start) on	ST2 (Reverse rotation start) on
0	CCW rotation	CW rotation
1	CW rotation	CCW rotation

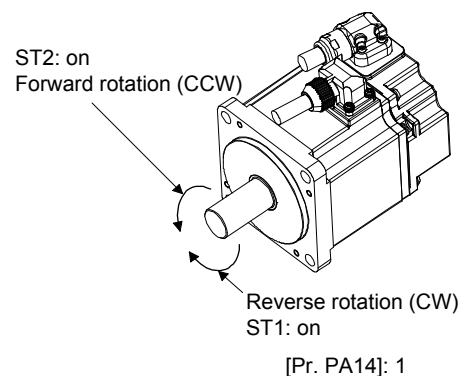
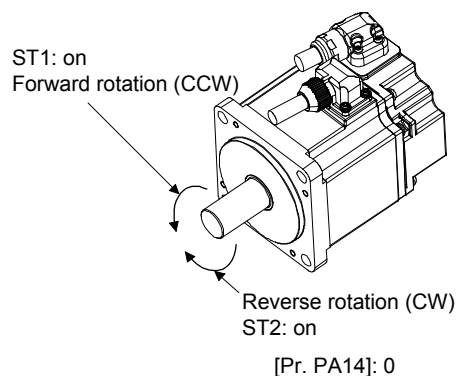

(3) Operation

When ST1 is switched on, the servo motor rotates using the JOG speed set in [Pr. PT13] and the acceleration/deceleration constants set with [Pr. PC02] and [Pr. PC03]. For the rotation direction, refer to (2) of this section. Switching on ST2 rotates the servo motor opposite to the direction of ST1 (Forward rotation start).

5. HOW TO USE THE PROGRAM

(4) Timing chart

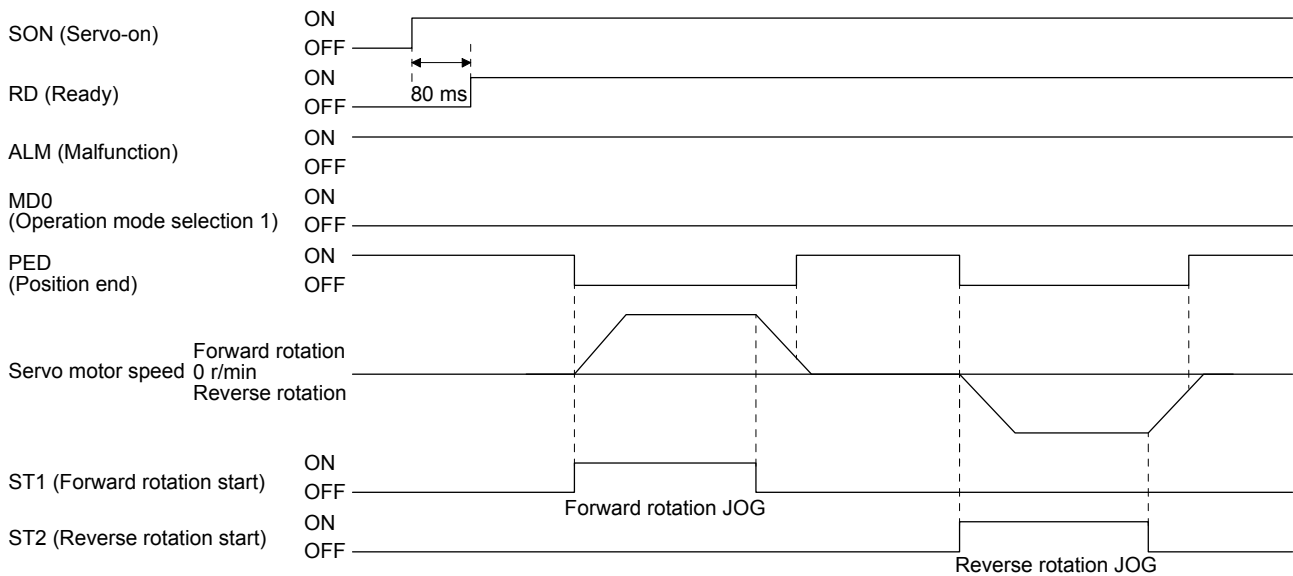

5.3.2 Manual pulse generator operation

(1) Setting

POINT
<ul style="list-style-type: none"> To enhance noise tolerance, set "_ 2 _" to [Pr. PA13] when the command pulse frequency is 500 kpulses/s or less, or set "_ 3 _" to [Pr. PA13] when the command pulse frequency is 200 kpulses/s or less.

According to the purpose of use, set input signals and parameters as shown below. In this case, DI0 (Program No. selection 1) to DI7 (Program No. selection 8) are invalid.

Item	Setting method	Setting
Manual operation mode selection	MD0 (Operation mode selection 1)	Switch off MD0.
Manual pulse generator multiplication	[Pr. PT03]	Set the multiplication factor for the pulses generated from the manual pulse generator. For details, refer to (3) of this section.
Servo motor rotation direction	[Pr. PA14]	Refer to (2) of this section.
Command input pulse train input form	[Pr. PA13]	Set "_ _ _ 2" (A/B-phase pulse train).
Pulse train filter selection	[Pr. PA13]	Set other than "_ 0 _" and "_ 1 _".

5. HOW TO USE THE PROGRAM

(2) Servo motor rotation direction

[Pr. PA14] setting	Servo motor rotation direction	
	Manual pulse generator operation: forward rotation	Manual pulse generator operation: reverse rotation
0	CCW rotation	CW rotation
1	CW rotation	CCW rotation

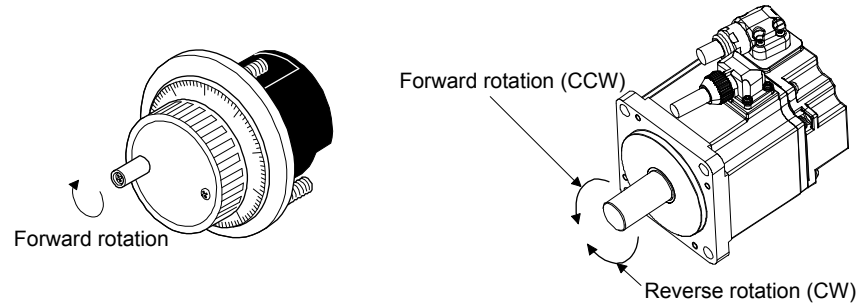

(3) Manual pulse generator multiplication

(a) Setting with input signals

In "Device setting" of MR Configurator2, set TP0 (Manual pulse generator multiplication 1) and TP1 (Manual pulse generator multiplication 2) for input signals.

TP1 (Pulse generator multiplication 2) (Note)	TP0 (Pulse generator multiplication 1) (Note)	Servo motor rotation multiplication to manual pulse generator rotation amount	Travel distance			
			[mm]	[inch]	[degree]	[pulse]
0	0	[Pr. PT03] setting valid				
0	1	1 time	0.001	0.0001	0.001	1
1	0	10 times	0.01	0.001	0.01	10
1	1	100 times	0.1	0.01	0.1	100

Note. 0: Off

1: On

(b) Setting with a parameter

Using [Pr. PT03], set the servo motor rotation multiplication factor for the rotation amount of the manual pulse generator.

[Pr. PT03] setting	Servo motor rotation multiplication to manual pulse generator rotation amount	Travel distance			
		[mm]	[inch]	[degree]	[pulse]
__ 0 __	1 time	0.001	0.0001	0.001	1
__ 1 __	10 times	0.01	0.001	0.01	10
__ 2 __	100 times	0.1	0.01	0.1	100

(4) Operation

Turning the manual pulse generator rotates the servo motor. For the rotation direction of the servo motor, refer to (2) of this section.

5. HOW TO USE THE PROGRAM

5.4 Home position return mode

POINT
<ul style="list-style-type: none">● Before performing the home position return, make sure that the limit switch operates.● Check the home position return direction. An incorrect setting will cause a reverse running.● Check the proximity dog input polarity. Otherwise, it may cause an overrun and malfunction.● In the following cases, make sure that the Z-phase has been passed through once before performing a home position return.<ul style="list-style-type: none">▪ When an incremental linear encoder is used in the linear servo motor control mode▪ When an incremental external encoder is used in the fully closed loop control mode▪ When a servo amplifier is used in the DD motor control modeZ-phase unpassed will trigger [AL. 90.5 Home position return incomplete warning].● For servo amplifiers with software version B6 or earlier, the dog type last Z-phase reference home return and dogless Z-phase reference home position return cannot be used in the following operation modes.<ul style="list-style-type: none">▪ Fully closed loop control mode using an incremental linear encoder▪ Linear servo motor control mode using an incremental linear encoder▪ Direct drive motor control modeSetting [Pr. PT04 Home position return type] to "___ 8" or "___ A" will trigger [AL. 37 Parameter error].

5.4.1 Summary of home position return

A home position return is performed to match the command coordinates with the machine coordinates. Under the incremental method, each power-on of the input power supply requires the home position return. In the absolute position detection system, once you have performed the home position return at machine installation, the current position will be retained even if the power supply is shut off. Therefore, the home position return is unnecessary when the power supply is switched on again.

This section shows the home position return methods of the servo amplifier. Select the optimum method according to the configuration and uses of the machine.

This servo amplifier has the home position return automatic retract function. When the machine stops beyond or on a proximity dog, this function automatically moves the machine back to the proper position to perform the home position return. Manually moving the machine by the JOG operation or others is unnecessary.

5. HOW TO USE THE PROGRAM

(1) Home position return type

Select the optimum home position return type according to the machine type or others.

Type	Home position return method	Feature
Dog type	Deceleration starts at the front end of a proximity dog. After the rear end is passed, the position specified by the first Z-phase signal or the position of the first Z-phase signal shifted by the specified home position shift distance is used as the home position. The servo amplifier internally recognizes the Z-phase signal one time per servo motor revolution. The Z-phase signal cannot be used as an output signal.	<ul style="list-style-type: none"> • General home position return method using a proximity dog • The repeatability of the home position return is high. • The machine is less loaded. • Used when the width of the proximity dog can be set equal to or greater than the deceleration distance of the servo motor.
Count type	Deceleration starts at the front end of a proximity dog. After the rear end is passed, the position is shifted by the travel distance. Then, the position specified by the first Z-phase signal or the position of the Z-phase signal shifted by the specified home position shift distance is used as the home position.	<ul style="list-style-type: none"> • Home position return method using a proximity dog • Used to minimize the length of the proximity dog.
Data set type	The position shifted by any distance manually is used as the home position.	<ul style="list-style-type: none"> • No proximity dog is required.
Stopper type	A workpiece is pressed against a mechanical stopper, and the position where it is stopped is used as the home position.	<ul style="list-style-type: none"> • Since the workpiece collides with the mechanical stopper, the home position return speed must be low enough. • The strength of the machine and stopper must be increased.
Home position ignorance (servo-on position as home position)	The position at servo-on is used as the home position.	
Dog type rear end reference	Deceleration starts at the front end of a proximity dog. After the rear end is passed, the position is shifted by the travel distance after proximity dog and the home position shift distance. The position after the shifts is used as the home position.	<ul style="list-style-type: none"> • The Z-phase signal is not required.
Count type front end reference	Deceleration starts at the front end of a proximity dog. The position is shifted by the travel distance after proximity dog and the home position shift distance. The position after the shifts is used as the home position.	<ul style="list-style-type: none"> • The Z-phase signal is not required.
Dog cradle type	After the front end of a proximity dog is detected, the position specified by the first Z-phase signal is used as the home position.	
Dog type last Z-phase reference	After the front end of a proximity dog is detected, the position is shifted away from the proximity dog in the reverse direction. Then, the position specified by the first Z-phase signal or the position of the first Z-phase signal shifted by the home position shift distance is used as the home position.	
Dog type front end reference	Starting from the front end of a proximity dog, the position is shifted by the travel distance after proximity dog and the home position shift distance. The position after the shifts is used as the home position.	<ul style="list-style-type: none"> • The Z-phase signal is not required.
Dogless Z-phase reference	The position specified by the first Z-phase signal, or the position of the first Z-phase signal shifted by the home position shift distance is used as the home position.	

5. HOW TO USE THE PROGRAM

(2) Parameters for home position return

To perform the home position return, set each parameter as follows.

(a) Select the home position return type with [Pr. PT04 Home position return type].

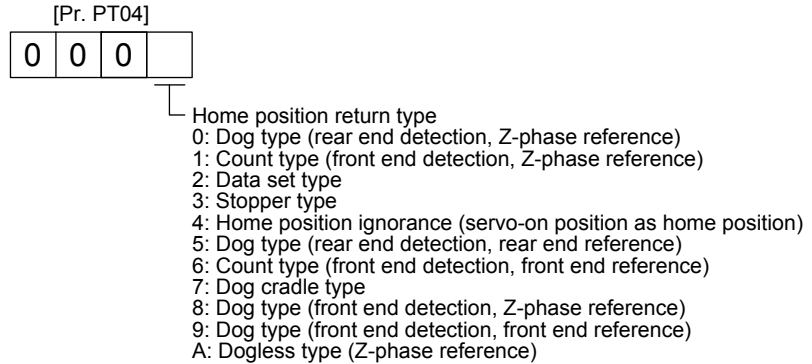

(b) Select the starting direction for the home position return with [Pr. PT04 Home position return type].

Setting "0" starts the home position return in the address increase direction from the current position.
 Setting "1" starts the home position return in the address decrease direction from the current position.

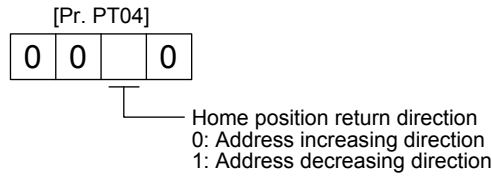

(c) Select the polarity where the proximity dog is detected with the DOG (Proximity dog) polarity selection of [Pr. PT29 Function selection T-3]. Setting "0" detects the dog when DOG (Proximity dog) is off. Setting "1" detects the dog when DOG (Proximity dog) is on.

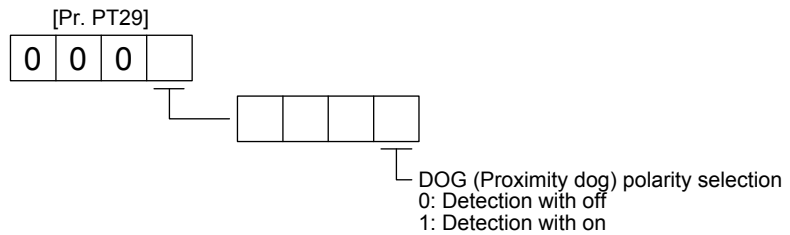

(3) Program

Select a program containing a "ZRT" command, which performs the home position return.

5. HOW TO USE THE PROGRAM

5.4.2 Dog type home position return

This is a home position return method using a proximity dog. Deceleration starts at the front end of the proximity dog. After the rear end is passed, the position specified by the first Z-phase signal, or the position of the first Z-phase signal shifted by the specified home position shift distance is used as the home position.

(1) Device/parameter

Set input devices and parameters as shown below.

Item	Used device/parameter	Setting
Automatic operation mode of the program method	MD0 (Operation mode selection 1)	Switch on MD0.
Dog type home position return	[Pr. PT04]	___0: Select the dog type (rear end detection/Z-phase reference).
Home position return direction	[Pr. PT04]	Refer to (2) of section 5.4.1 to select the home position return direction.
Dog input polarity	[Pr. PT29]	Refer to (2) of section 5.4.1 to select the dog input polarity.
Home position return speed	[Pr. PT05]	Set the rotation speed specified until a dog is detected.
Creep speed	[Pr. PT06]	Set the rotation speed specified after a dog is detected.
Home position shift distance	[Pr. PT07]	Set this item to shift the home position, which is specified by the first Z-phase signal after the rear end of a proximity dog is passed.
Home position return acceleration time constant	[Pr. PC30]	The acceleration time constant set for [Pr. PC30] is used.
Home position return deceleration time constant	[Pr. PC31]	The deceleration time constant set for [Pr. PC31] is used.
Home position return position data	[Pr. PT08]	Set the current position at the home position return completion.
Program	D10 (Program No. selection 1) to D17 (Program No. selection 8)	Select a program containing a "ZRT" command, which performs the home position return.

(2) Length of the proximity dog

To generate the Z-phase signal of the servo motor during the detection of DOG (Proximity dog), set the length of the proximity dog that satisfies equations (5.1) and (5.2).

$$L_1 \geq \frac{V}{60} \cdot \frac{td}{2} \dots\dots\dots (5.1)$$

L₁: Length of the proximity dog [mm]
V: Home position return speed [mm/min]
td: Deceleration time [s]

$$L_2 \geq 2 \cdot \Delta S \dots\dots\dots (5.2)$$

L₂: Length of the proximity dog [mm]
ΔS: Travel distance per servo motor revolution [mm]

5. HOW TO USE THE PROGRAM

(3) Timing chart

The following shows a timing chart after a program containing a "ZRT" command is selected.

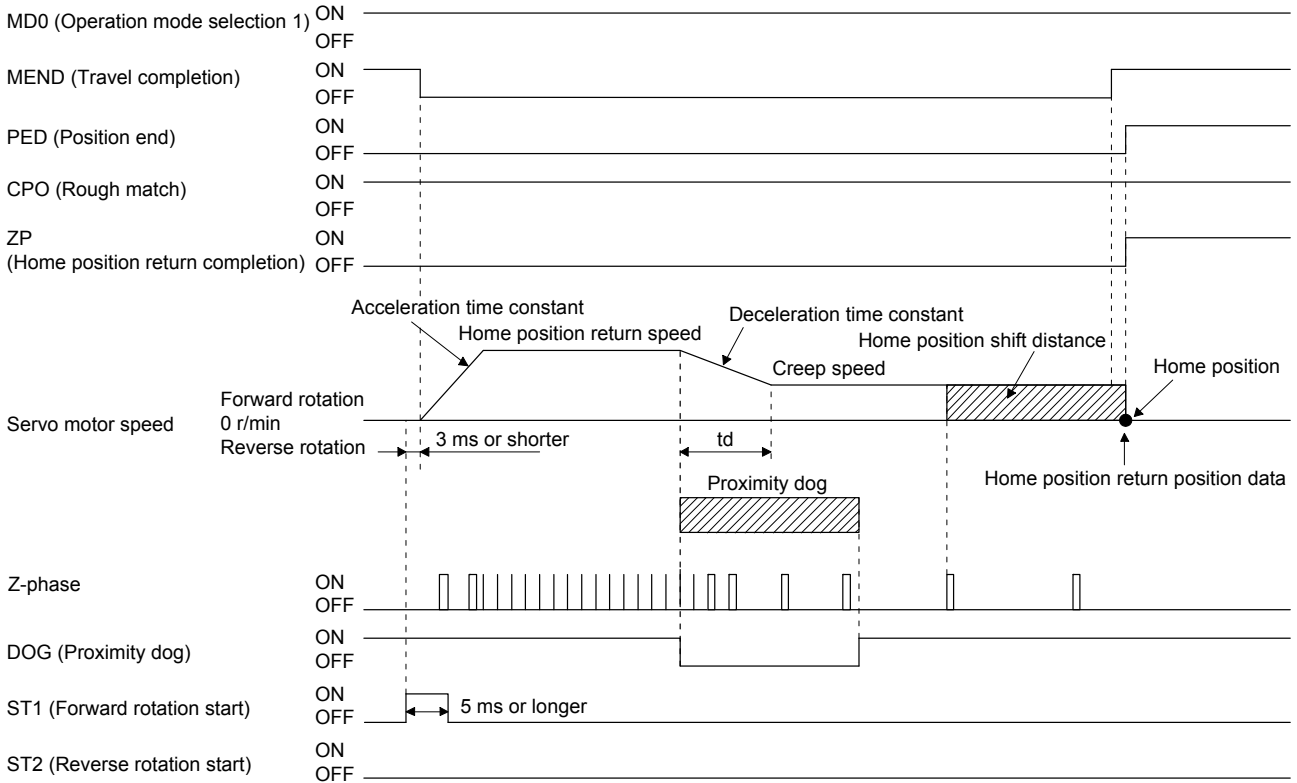

The setting value of [Pr. PT08 Home position return position data] is used as the position address at the home position return completion.

(4) Adjustment

For the dog type home position return, adjust the setting so that the Z-phase signal is always generated during the detection of a dog. Make an adjustment so that the rear end of DOG (Proximity dog) is positioned almost at the center between the position specified by a Z-phase signal and the position specified by the next Z-phase signal.

The generation position of the Z-phase signal can be checked with "Position within one-revolution" of "Status Display" on MR Configurator2.

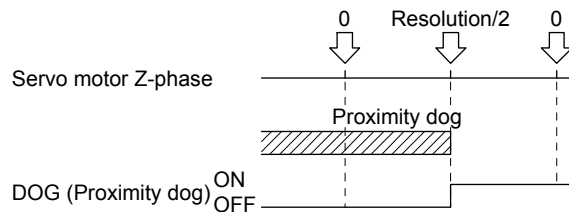

5. HOW TO USE THE PROGRAM

5.4.3 Count type home position return

For the count type home position return, after the front end of a proximity dog is detected, the position is shifted by the distance set for [Pr. PT09 Travel distance after proximity dog]. Then, the position specified by the first Z-phase signal is used as the home position. Therefore, when the on time of DOG (Proximity dog) is 10 ms or more, the length of the proximity dog has no restrictions. Use the count type home position return when you cannot use the dog type home position return because the length of the proximity dog cannot be reserved, when you input DOG (Proximity dog) electrically from the controller, or other cases.

(1) Device/parameter

Set input devices and parameters as shown below.

Item	Used device/parameter	Setting
Automatic operation mode of the program method	MD0 (Operation mode selection 1)	Switch on MD0.
Count type home position return	[Pr. PT04]	__ _ 1: Select the count type (front end detection Z-phase reference).
Home position return direction	[Pr. PT04]	Refer to (2) of section 5.4.1 to select the home position return direction.
Dog input polarity	[Pr. PT29]	Refer to (2) of section 5.4.1 to select the dog input polarity.
Home position return speed	[Pr. PT05]	Set the rotation speed specified until a dog is detected.
Creep speed	[Pr. PT06]	Set the rotation speed specified after a dog is detected.
Home position shift distance	[Pr. PT07]	After the front end of a proximity dog is passed, the position is shifted by the travel distance and then is specified by the first Z-phase signal. Set this item to shift the position of the first Z-phase signal.
Travel distance after proximity dog	[Pr. PT09]	Set the travel distance specified after the front end of the proximity dog is passed.
Home position return acceleration time constant	[Pr. PC30]	The acceleration time constant set for [Pr. PC30] is used.
Home position return deceleration time constant	[Pr. PC31]	The deceleration time constant set for [Pr. PC31] is used.
Home position return position data	[Pr. PT08]	Set the current position at the home position return completion.
Program	D10 (Program No. selection 1) to D17 (Program No. selection 8)	Select a program containing a "ZRT" command, which performs the home position return.

5. HOW TO USE THE PROGRAM

(2) Timing chart

The following shows a timing chart after a program containing a "ZRT" command is selected.

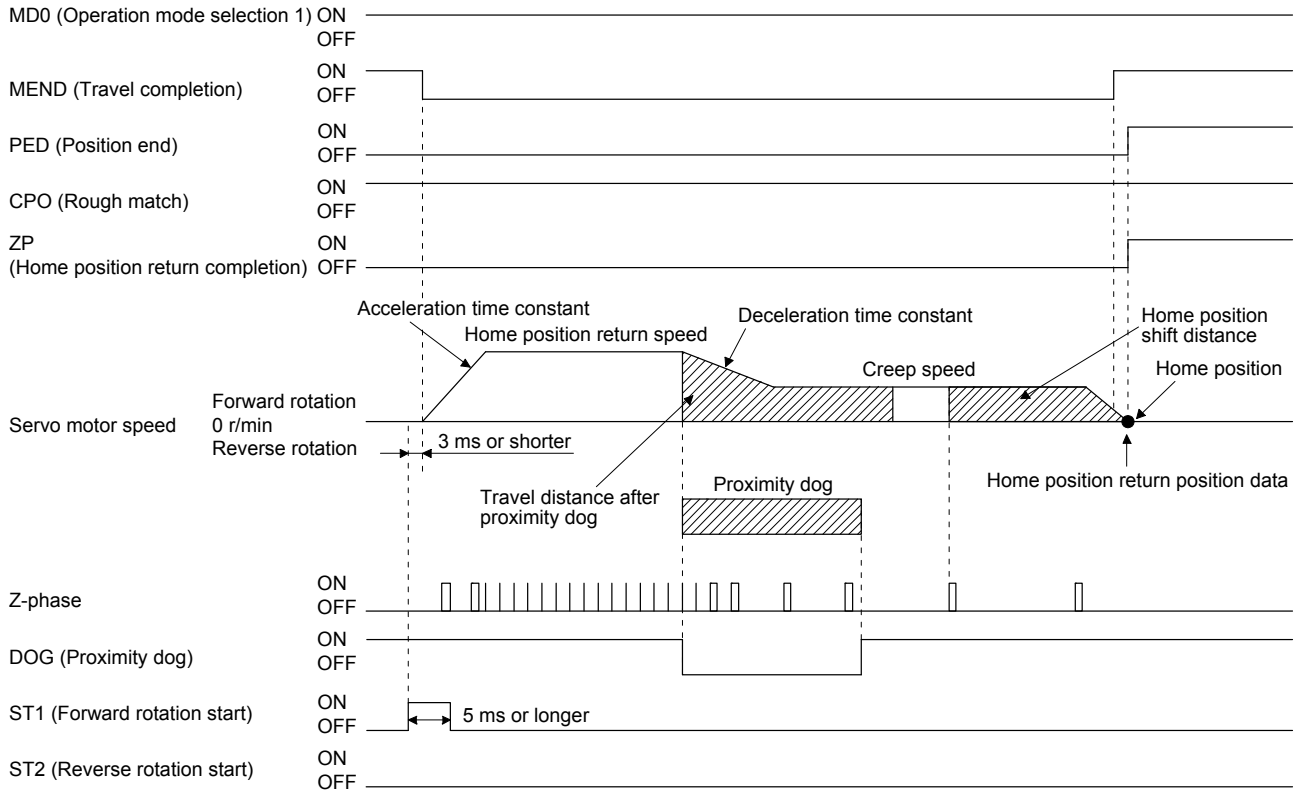

The setting value of [Pr. PT08 Home position return position data] is used as the position address at the home position return completion.

5. HOW TO USE THE PROGRAM

5.4.4 Data set type home position return

To specify any position as the home position, use the data set type home position return. To shift the position, you can use the JOG operation, the manual pulse generator operation, or others. The data set type home position return can be performed only at servo-on.

(1) Device/parameter

Set input devices and parameters as shown below.

Item	Used device/parameter	Setting
Automatic operation mode of the program method	MD0 (Operation mode selection 1)	Switch on MD0.
Data set type home position return	[Pr. PT04]	___ 2: Select the data set type.
Home position return position data	[Pr. PT08]	Set the current position at the home position return completion.
Program	D10 (Program No. selection 1) to D17 (Program No. selection 8)	Select a program containing a "ZRT" command, which performs the home position return.

(2) Timing chart

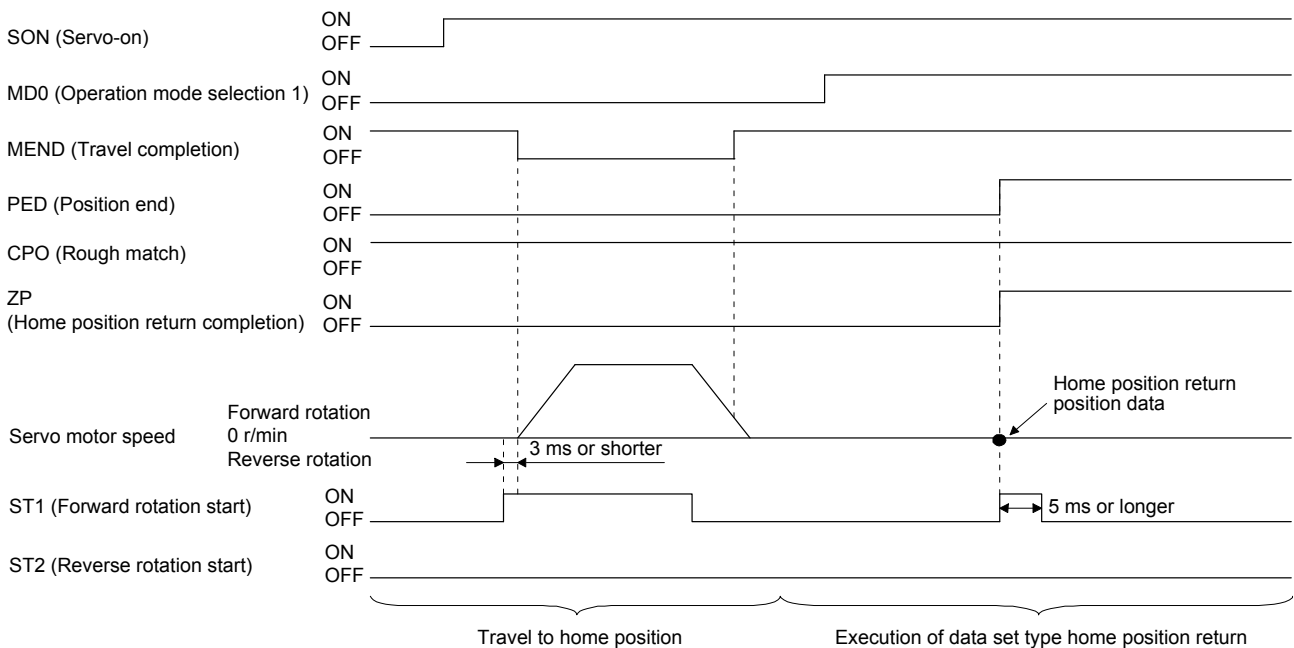

The setting value of [Pr. PT08 Home position return position data] is used as the position address at the home position return completion.

5. HOW TO USE THE PROGRAM

5.4.5 Stopper type home position return

For the stopper type home position return, by using the JOG operation, manual pulse generator operation, or others, a workpiece is pressed against a mechanical stopper, and the position where it is stopped is used as the home position.

(1) Device/parameter

Set input devices and parameters as shown below.

Item	Used device/parameter	Setting
Automatic operation mode of the program method	MD0 (Operation mode selection 1)	Switch on MD0.
Stopper type home position return	[Pr. PT04]	___ 3: Select the stopper type.
Home position return direction	[Pr. PT04]	Refer to (2) of section 5.4.1 to select the home position return direction.
Home position return speed	[Pr. PT05]	Set the rotation speed until the workpiece is pressed against the mechanical stopper.
Stopper time	[Pr. PT10]	Set the time from when the home position data is obtained after the workpiece is pressed against the stopper until when ZP (home position return completion) is outputted.
Stopper type home position return torque limit value	[Pr. PT11]	Set the servo motor torque limit value at the execution of the stopper type home position return.
Home position return acceleration time constant	[Pr. PC30]	The acceleration time constant set for [Pr. PC30] is used.
Home position return deceleration time constant	[Pr. PC31]	The deceleration time constant set for [Pr. PC31] is used.
Home position return position data	[Pr. PT08]	Set the current position at the home position return completion.
Program	D10 (Program No. selection 1) to D17 (Program No. selection 8)	Select a program containing a "ZRT" command, which performs the home position return.

(2) Timing chart

The following shows a timing chart after a program containing a "ZRT" command is selected.

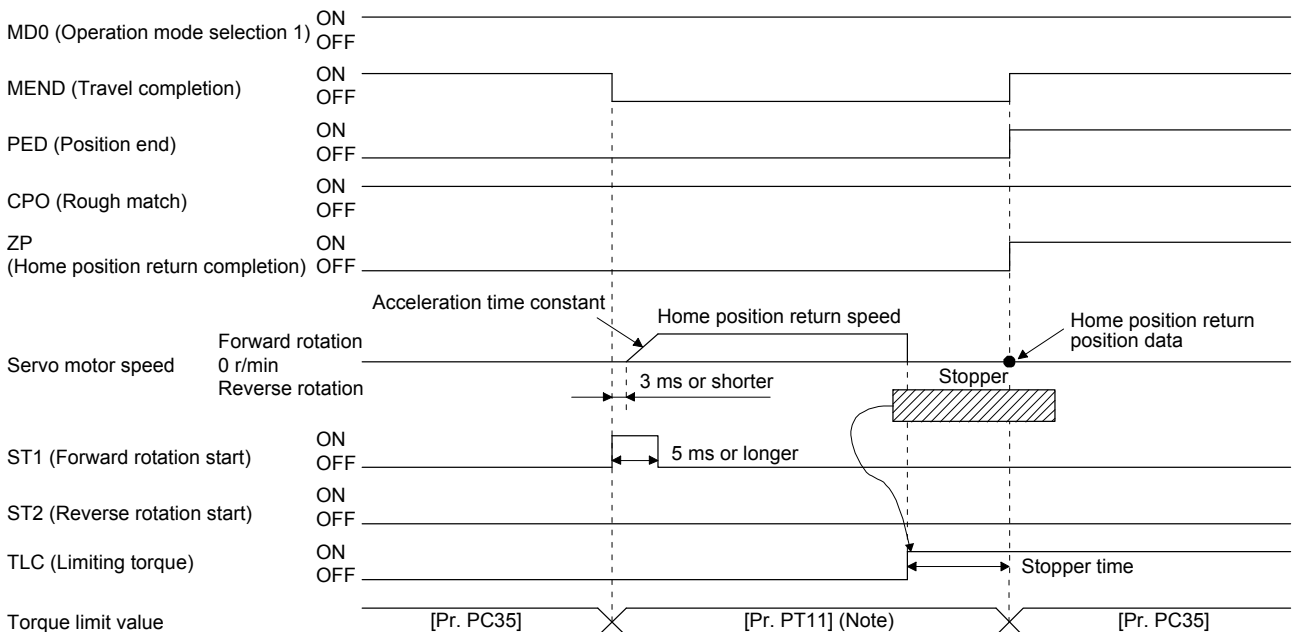

Note. The following torque limits are enabled.

5. HOW TO USE THE PROGRAM

Input device (0: Off, 1: On)		Limit value status			Enabled torque limit value
TL1	TL				
0	0				Pr. PT11
0	1	TLA	>	Pr. PT11	Pr. PT11
		TLA	<	Pr. PT11	TLA
1	0	Pr. PC35	>	Pr. PT11	Pr. PT11
		Pr. PC35	<	Pr. PT11	Pr. PC35
1	1	TLA	>	Pr. PT11	Pr. PT11
		TLA	<	Pr. PT11	TLA

The setting value of [Pr. PT08 Home position return position data] is used as the position address at the home position return completion.

5.4.6 Home position ignorance (servo-on position as home position)

POINT
<ul style="list-style-type: none"> ● To perform a home position return by using the home position ignorance, selecting a program containing a "ZRT" command is not required.

The position at servo-on is used as the home position.

(1) Device/parameter

Set input devices and parameters as shown below.

Item	Used device/parameter	Setting
Home position ignorance	[Pr. PT04]	___ 4: Select the home position ignorance (servo-on position as home position).
Home position return position data	[Pr. PT08]	Set the current position at the home position return completion.

(2) Timing chart

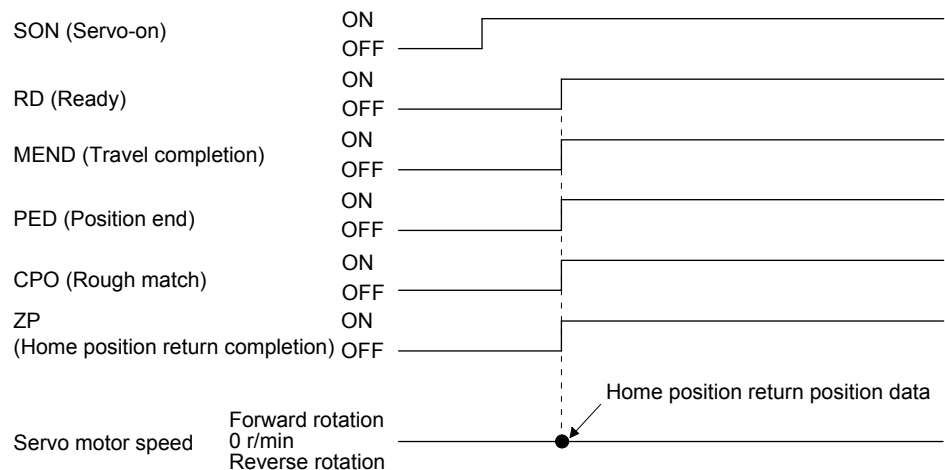

The setting value of [Pr. PT08 Home position return position data] is used as the position address at the home position return completion.

5. HOW TO USE THE PROGRAM

5.4.7 Dog type rear end reference home position return

POINT
<p>● This home position return method depends on the timing of reading DOG (Proximity dog) that has detected the rear end of a proximity dog. Therefore, when a home position return is performed at a creep speed of 100 r/min, the home position has an error of 6400 pulses (for HG series servo motor). The higher the creep speed, the greater the error of the home position.</p>

Deceleration starts at the front end of a proximity dog. After the rear end is passed, the position is shifted by the travel distance after proximity dog and the home position shift distance. The position after the shifts is used as the home position. The home position return is available independently of the Z-phase signal.

(1) Device/parameter

Set input devices and parameters as shown below.

Item	Used device/parameter	Setting
Automatic operation mode of the program method	MD0 (Operation mode selection 1)	Switch on MD0.
Dog type rear end reference home position return	[Pr. PT04]	___ 5: Select the dog type (rear end detection/rear end reference).
Home position return direction	[Pr. PT04]	Refer to (2) of section 5.4.1 to select the home position return direction.
Dog input polarity	[Pr. PT29]	Refer to (2) of section 5.4.1 to select the dog input polarity.
Home position return speed	[Pr. PT05]	Set the rotation speed specified until a dog is detected.
Creep speed	[Pr. PT06]	Set the rotation speed specified after a dog is detected.
Home position shift distance	[Pr. PT07]	Set this item to shift the home position, which is specified after the rear end of a proximity dog is passed.
Travel distance after proximity dog	[Pr. PT09]	Set the travel distance specified after the rear end of a proximity dog is passed.
Home position return acceleration time constant	[Pr. PC30]	The acceleration time constant set for [Pr. PC30] is used.
Home position return deceleration time constant	[Pr. PC31]	The deceleration time constant set for [Pr. PC31] is used.
Home position return position data	[Pr. PT08]	Set the current position at the home position return completion.
Program	D10 (Program No. selection 1) to D17 (Program No. selection 8)	Select a program containing a "ZRT" command, which performs the home position return.

5. HOW TO USE THE PROGRAM

(2) Timing chart

The following shows a timing chart after a program containing a "ZRT" command is selected.

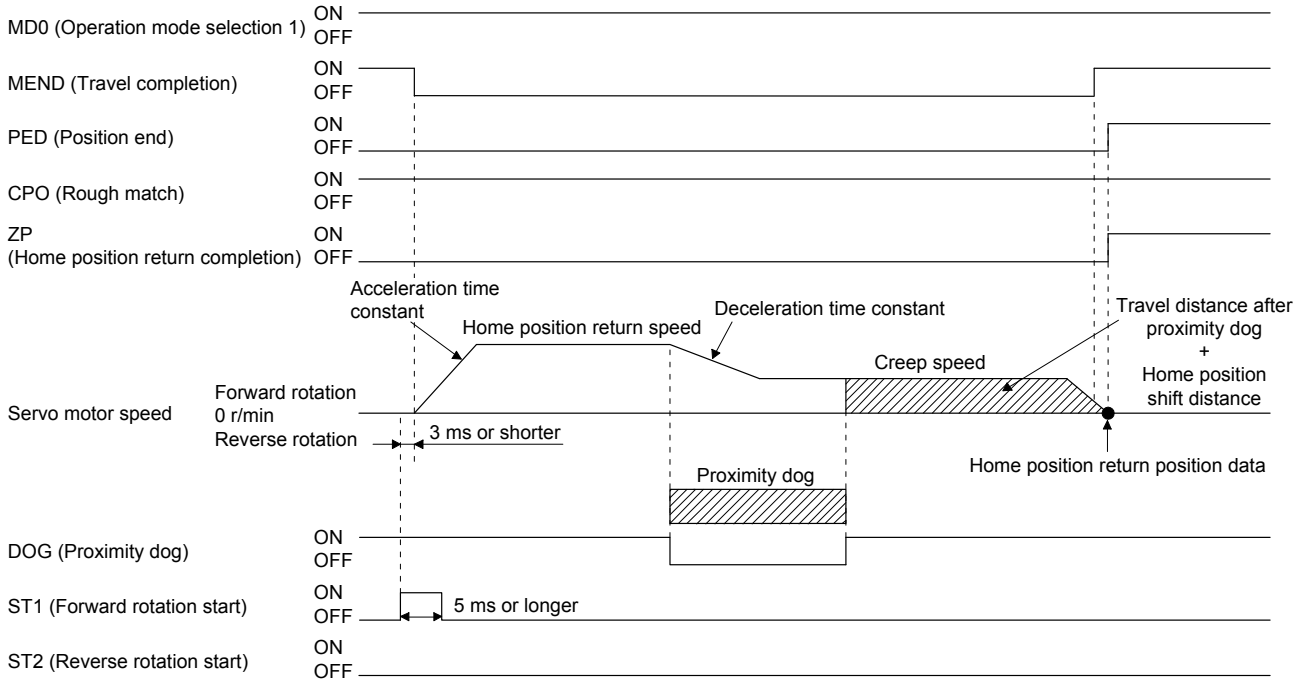

The setting value of [Pr. PT08 Home position return position data] is used as the position address at the home position return completion.

5. HOW TO USE THE PROGRAM

5.4.8 Count type front end reference home position return

POINT
<ul style="list-style-type: none"> ● This home position return method depends on the timing of reading DOG (Proximity dog) that has detected the front end of a proximity dog. Therefore, when a home position return is performed at a creep speed of 100 r/min, the home position has an error of 6400 pulses (for HG series servo motor). The higher the creep speed, the greater the error of the home position. ● After the front end of a proximity dog is detected, when a home position return ends without reaching the creep speed, [AL. 90.2] occurs. Set the travel distance after proximity dog and the home position shift distance enough for deceleration from the home position return speed to the creep speed.

(1) Device/parameter

Set input devices and parameters as shown below.

Item	Used device/parameter	Setting
Automatic operation mode of the program method	MD0 (Operation mode selection 1)	Switch on MD0.
Count type front end reference home position return	[Pr. PT04]	___ 6: Select the count type (front end detection/front end reference).
Home position return direction	[Pr. PT04]	Refer to (2) of section 5.4.1 to select the home position return direction.
Dog input polarity	[Pr. PT29]	Refer to (2) of section 5.4.1 to select the dog input polarity.
Home position return speed	[Pr. PT05]	Set the rotation speed specified until a dog is detected.
Creep speed	[Pr. PT06]	Set the rotation speed specified after a dog is detected.
Home position shift distance	[Pr. PT07]	Set this to shift the home position, which is specified after the front end of a proximity dog is passed.
Travel distance after proximity dog	[Pr. PT09]	Set the travel distance specified after the front end of the proximity dog is passed.
Home position return acceleration time constant	[Pr. PC30]	The acceleration time constant set for [Pr. PC30] is used.
Home position return deceleration time constant	[Pr. PC31]	The deceleration time constant set for [Pr. PC31] is used.
Home position return position data	[Pr. PT08]	Set the current position at the home position return completion.
Program	D10 (Program No. selection 1) to D17 (Program No. selection 8)	Select a program containing a "ZRT" command, which performs the home position return.

5. HOW TO USE THE PROGRAM

(2) Timing chart

The following shows a timing chart after a program containing a "ZRT" command is selected.

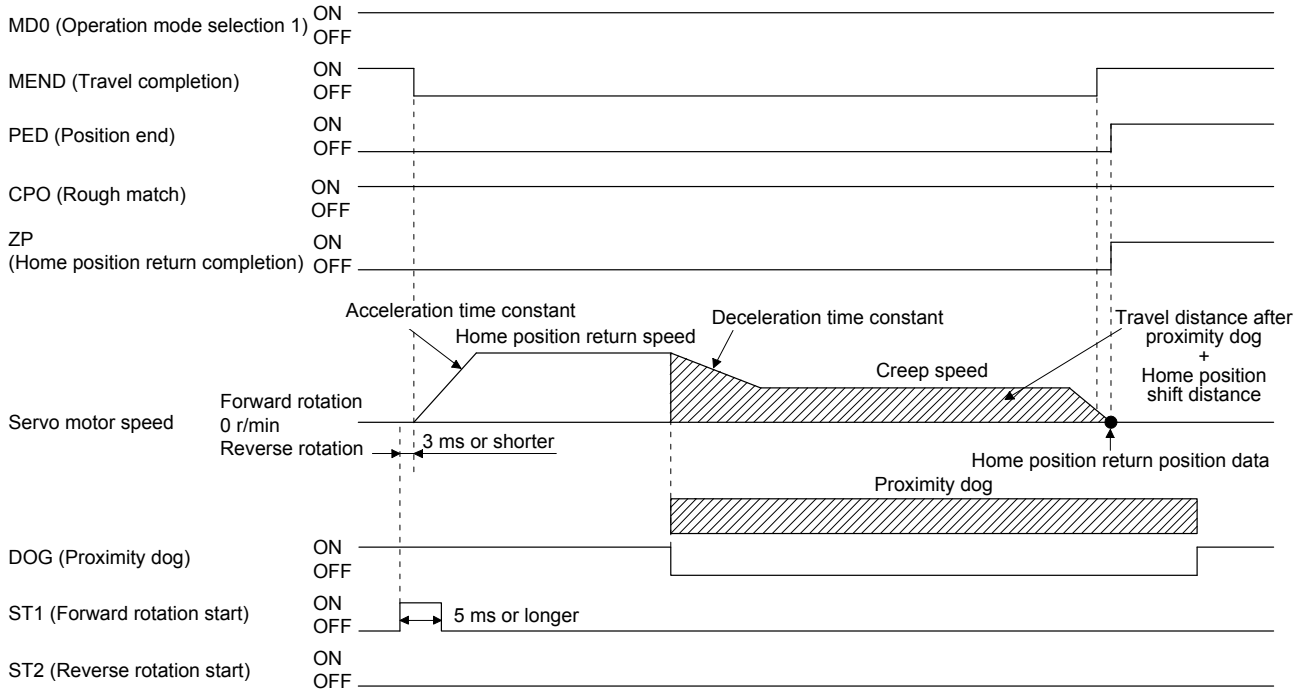

The setting value of [Pr. PT08 Home position return position data] is used as the position address at the home position return completion.

5. HOW TO USE THE PROGRAM

5.4.9 Dog cradle type home position return

You can use the position, which is specified by the first Z-phase signal after the front end of a proximity dog is detected, as the home position.

(1) Device/parameter

Set input devices and parameters as shown below.

Item	Used device/parameter	Setting
Automatic operation mode of the program method	MD0 (Operation mode selection 1)	Switch on MD0.
Dog cradle type home position return	[Pr. PT04]	___7: Select the dog cradle type.
Home position return direction	[Pr. PT04]	Refer to (2) of section 5.4.1 to select the home position return direction.
Dog input polarity	[Pr. PT29]	Refer to (2) of section 5.4.1 to select the dog input polarity.
Home position return speed	[Pr. PT05]	Set the rotation speed specified until a dog is detected.
Creep speed	[Pr. PT06]	Set the rotation speed specified after a dog is detected.
Home position shift distance	[Pr. PT07]	Set this item to shift the home position, which is specified by the Z-phase signal.
Home position return acceleration time constant	[Pr. PC30]	The acceleration time constant set for [Pr. PC30] is used.
Home position return deceleration time constant	[Pr. PC31]	The deceleration time constant set for [Pr. PC31] is used.
Home position return position data	[Pr. PT08]	Set the current position at the home position return completion.
Program	D10 (Program No. selection 1) to D17 (Program No. selection 8)	Select a program containing a "ZRT" command, which performs the home position return.

5. HOW TO USE THE PROGRAM

(2) Timing chart

The following shows a timing chart after a program containing a "ZRT" command is selected.

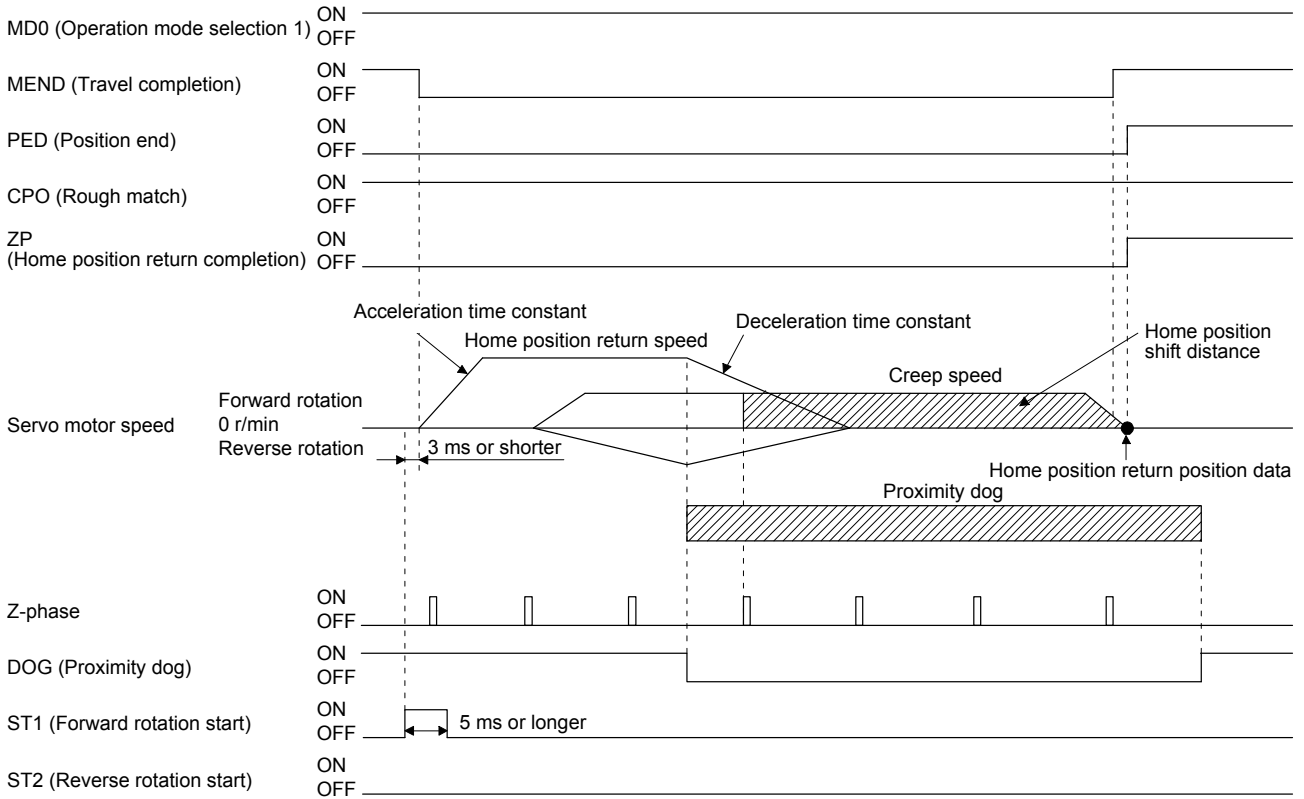

The setting value of [Pr. PT08 Home position return position data] is used as the position address at the home position return completion.

5. HOW TO USE THE PROGRAM

5.4.10 Dog type last Z-phase reference home position return

After the front end of a proximity dog is detected, the position is shifted away from the proximity dog at the creep speed in the reverse direction and then specified by the first Z-phase signal. The position of the first Z-phase signal is used as the home position.

(1) Device/parameter

Set input devices and parameters as shown below.

Item	Used device/parameter	Setting
Automatic operation mode of the program method	MD0 (Operation mode selection 1)	Switch on MD0.
Dog type last Z-phase reference home position return	[Pr. PT04]	___ 8: Select the dog type (front end detection/Z-phase reference).
Home position return direction	[Pr. PT04]	Refer to (2) of section 5.4.1 to select the home position return direction.
Dog input polarity	[Pr. PT29]	Refer to (2) of section 5.4.1 to select the dog input polarity.
Home position return speed	[Pr. PT05]	Set the rotation speed specified until a dog is detected.
Creep speed	[Pr. PT06]	Set the rotation speed specified after a dog is detected.
Home position shift distance	[Pr. PT07]	Set this item to shift the home position, which is specified by the Z-phase signal.
Home position return acceleration time constant	[Pr. PC30]	The acceleration time constant set for [Pr. PC30] is used.
Home position return deceleration time constant	[Pr. PC31]	The deceleration time constant set for [Pr. PC31] is used.
Home position return position data	[Pr. PT08]	Set the current position at the home position return completion.
Program	D10 (Program No. selection 1) to D17 (Program No. selection 8)	Select a program containing a "ZRT" command, which performs the home position return.

5. HOW TO USE THE PROGRAM

(2) Timing chart

The following shows a timing chart after a program containing a "ZRT" command is selected.

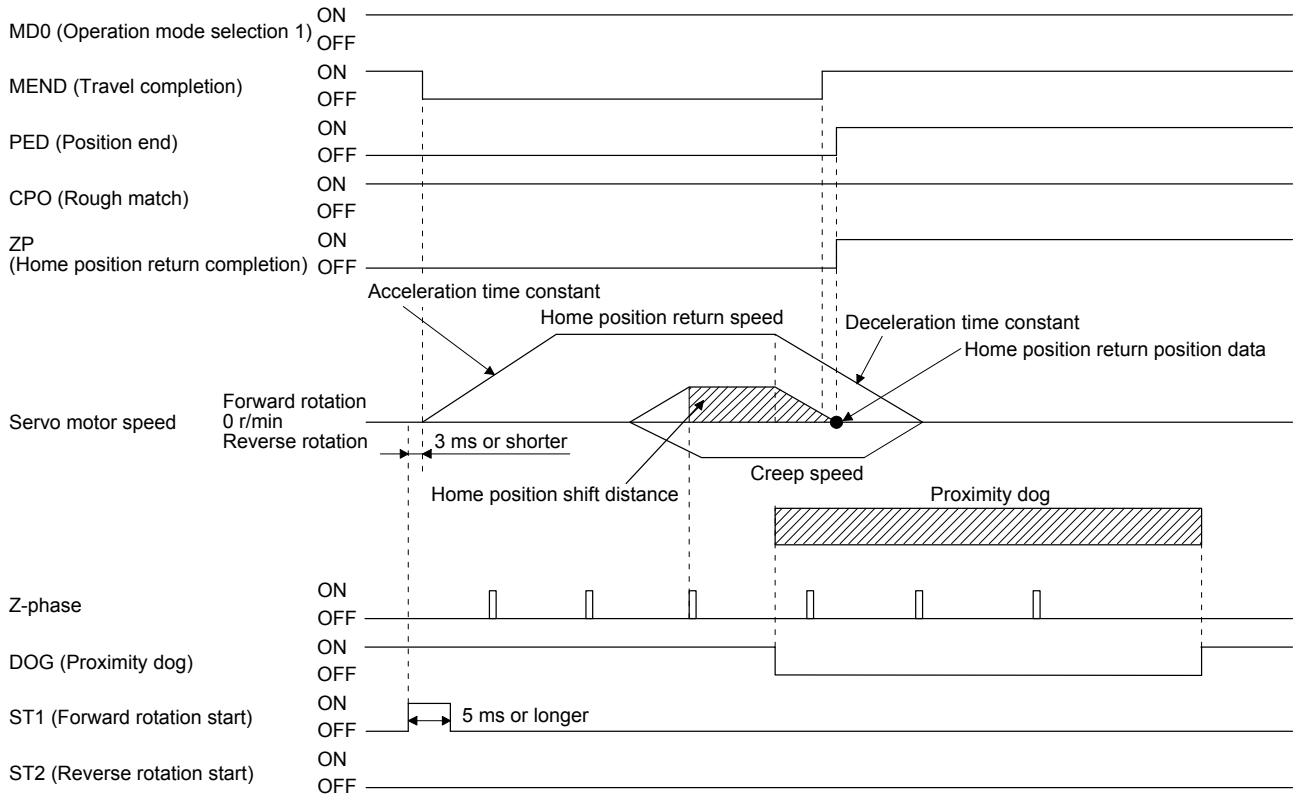

The setting value of [Pr. PT08 Home position return position data] is used as the position address at the home position return completion.

5. HOW TO USE THE PROGRAM

5.4.11 Dog type front end reference home position return type

POINT
<p>● This home position return method depends on the timing of reading DOG (Proximity dog) that has detected the front end of a proximity dog. Therefore, when a home position return is performed at a creep speed of 100 r/min, the home position has an error of 6400 pulses (for HG series servo motor). The higher the creep speed, the greater the error of the home position.</p>

The home position is where the machine moves the travel distance after proximity dog and the home position shift distance from the front end of a proximity dog.

The home position return is available independently of the Z-phase signal. Changing the creep speed may change the home position.

(1) Device/parameter

Set input devices and parameters as follows.

Item	Used device/parameter	Setting
Automatic operation mode of the program method	MD0 (Operation mode selection 1)	Switch on MD0.
Dog type front end reference home position return	[Pr. PT04]	___ 9: Select the dog type (front end detection/ front end reference).
Home position return direction	[Pr. PT04]	Refer to section 5.4.1 (2) to select the home position return direction.
Dog input polarity	[Pr. PT29]	Refer to section 5.4.1 (2) to select the dog input polarity.
Home position return speed	[Pr. PT05]	Set the rotation speed until a dog is detected.
Creep speed	[Pr. PT06]	Set the rotation speed after a dog is detected.
Home position shift distance	[Pr. PT07]	Set this item to move the home position set when the Z-phase signal is given.
Travel distance after proximity dog	[Pr. PT09]	Set the travel distance specified after the front end of the proximity dog is passed.
Home position return acceleration time constant	[Pr. PC30]	The acceleration time constant set for [Pr. PC30] is used.
Home position return deceleration time constant	[Pr. PC31]	The deceleration time constant set for [Pr. PC31] is used.
Home position return position data	[Pr. PT08]	Set a current position at home position return completion.
Program	D10 (Program No. selection 1) to D17 (Program No. selection 8)	Select a program containing "ZRT" command that performs a home position return.

5. HOW TO USE THE PROGRAM

(2) Timing chart

The following shows a timing chart after a program containing a "ZRT" command is selected.

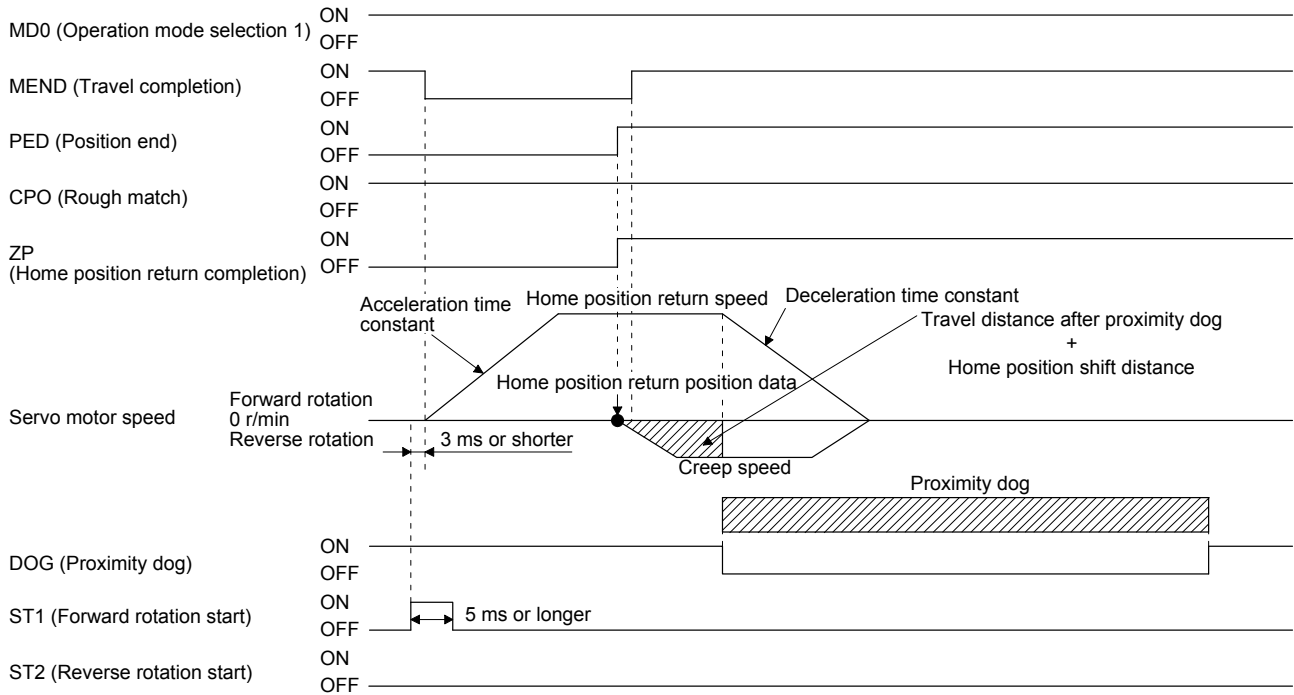

The setting value of [Pr. PT08 Home position return position data] is used as the position address at the home position return completion.

5. HOW TO USE THE PROGRAM

5.4.12 Dogless Z-phase reference home position return type

Starting from the Z-phase pulse position after the start of the home position return, the position is shifted by the home position shift distance. The position after the shifts is used as the home position.

(1) Device/parameter

Set input devices and parameters as follows.

Item	Used device/parameter	Setting
Automatic operation mode of the program method	MD0 (Operation mode selection 1)	Switch on MD0.
Dogless Z-phase reference home position return	[Pr. PT04]	___ A: Select the dogless type (Z-phase reference).
Home position return direction	[Pr. PT04]	Refer to section 5.4.1 (2) to select the home position return direction.
Dog input polarity	[Pr. PT29]	Refer to section 5.4.1 (2) to select the dog input polarity.
Home position return speed	[Pr. PT05]	Set the rotation speed until a dog is detected.
Creep speed	[Pr. PT06]	Set the rotation speed after a dog is detected.
Home position shift distance	[Pr. PT07]	Set this item to move the home position set when the Z-phase signal is given.
Home position return acceleration time constant	[Pr. PC30]	The acceleration time constant set for [Pr. PC30] is used.
Home position return deceleration time constant	[Pr. PC31]	The deceleration time constant set for [Pr. PC31] is used.
Home position return position data	[Pr. PT08]	Set a current position at home position return completion.
Program	D10 (Program No. selection 1) to D17 (Program No. selection 8)	Select a program containing "ZRT" command that performs a home position return.

(2) Timing chart

The following shows a timing chart after a program containing a "ZRT" command is selected.

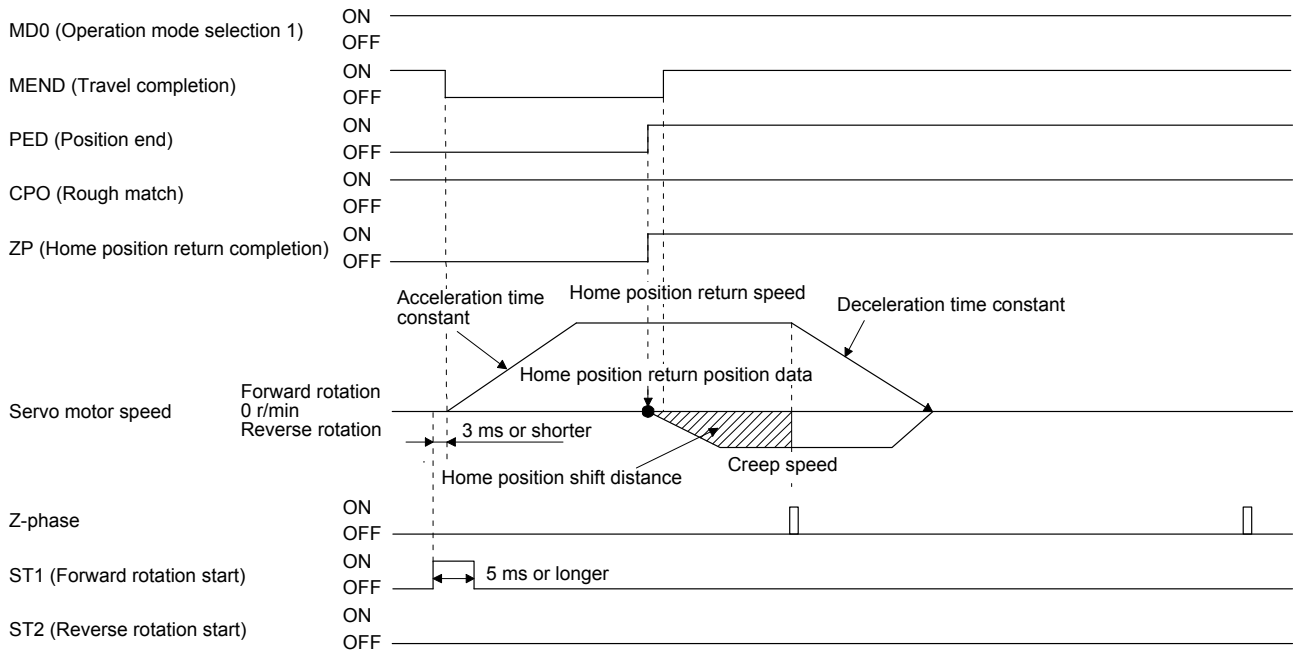

The setting value of [Pr. PT08 Home position return position data] is used as the position address at the home position return completion.

5. HOW TO USE THE PROGRAM

5.4.13 Automatic retract function used for the home position return

For a home position return using the proximity dog, when the home position return is started from the position on or beyond the proximity dog, the home position return is performed after the machine moves back to the position where the home position can be performed.

(1) When the current position is on the proximity dog

When the current position is on the proximity dog, the machine moves backward automatically, and the home position return is performed.

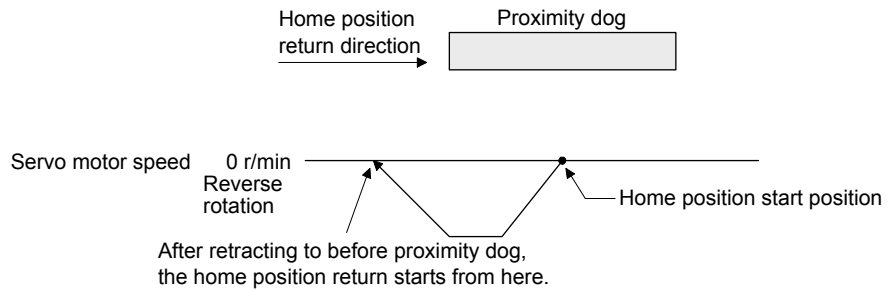

(2) When the current position is beyond the proximity dog

At start-up, the operation is performed in the direction of the home position return. When LSP (Forward rotation stroke end) or LSN (Reverse rotation stroke end) is detected, the machine moves backward automatically. The machine passes and stops before the proximity dog, and the home position return is performed from the position again. If the proximity dog cannot be detected, the machine stops at LSP or LSN on the opposite side, and [AL. 90 Home position return incomplete warning] will occur.

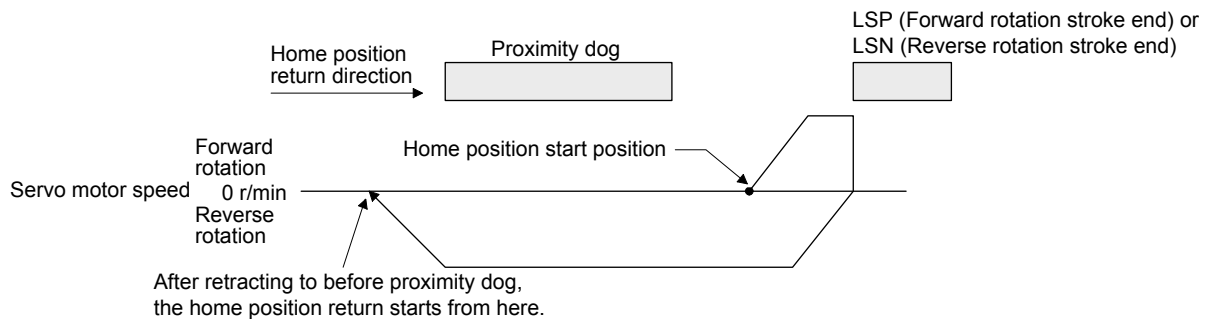

The software limit cannot be used with these functions.

5. HOW TO USE THE PROGRAM

5.5 Serial communication operation

Using the RS-422 communication function, you can use to operate a servo amplifier from the controller such as a personal computer.

This section explains the data communication procedure. Refer to chapter 10 for details of the connection between the controller and servo amplifier and of communication data.

5.5.1 Positioning operation using the program

Using the communication function can select program Nos., perform the positioning operation using the program by switching on ST1 (Forward rotation start).

(1) Program selection

Select program No. 1 to 256 using the forced output of the device from the controller (command [9] [2] and data No. [6] [0]).

(2) Timing chart

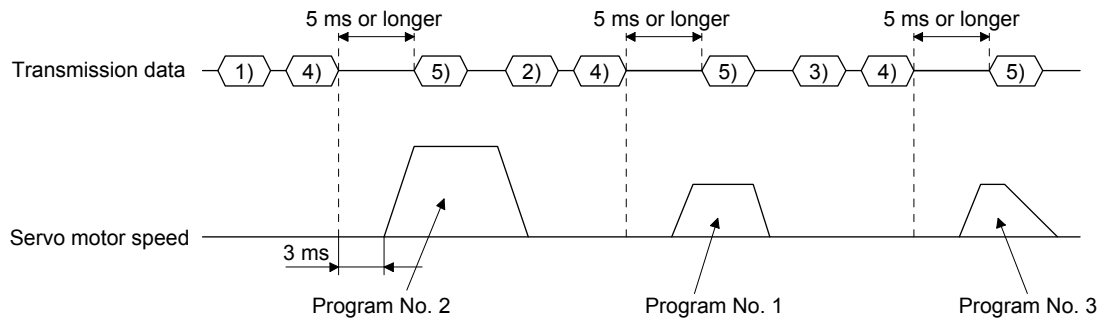

No.	Transmission data description	Command	Data No.
1)	Select Program No. 2.	[9] [2]	[6] [0]
2)	Select Program No. 1.	[9] [2]	[6] [0]
3)	Select Program No. 3.	[9] [2]	[6] [0]
4)	Switch on ST1 (Forward rotation start).	[9] [2]	[6] [0]
5)	Switch off ST1 (Forward rotation start).	[9] [2]	[6] [0]

5. HOW TO USE THE PROGRAM

5.5.2 Multi-drop method (RS-422 communication)

Using the RS-422 communication function can use to operate multiple servo amplifiers on the same bus. In this case, set station numbers to the servo amplifier because the controller recognizes that the data currently being sent is for which servo amplifier. Set station Nos. with [Pr. PC20 Station number setting].

Always set one station No. to one servo amplifier. Setting one station number to multiple servo amplifiers will disable a normal communication. When you use to operate multiple servo amplifiers under one command, use the group specification function in section 5.5.3.

(1) MR-J4-_A_-RJ 100 W or more

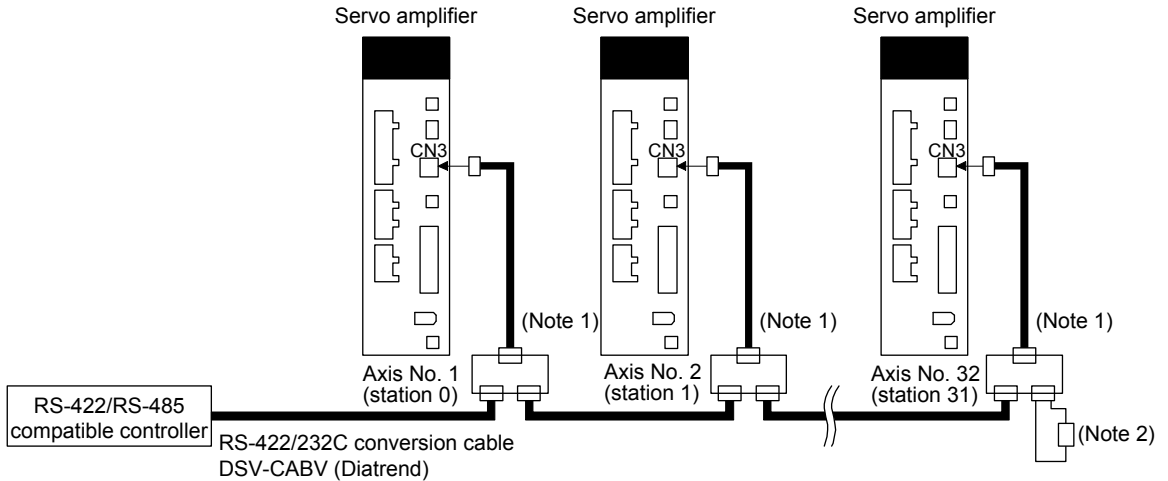

Note 1. The BMJ-8 (Hachiko Electric) is recommended as the branch connector.

Note 2. The final axis must be terminated between RDP (pin No. 3) and RDN (pin No. 6) on the receiving side (servo amplifier) with a 150 Ω resistor.

(2) MR-J4-03A6-RJ

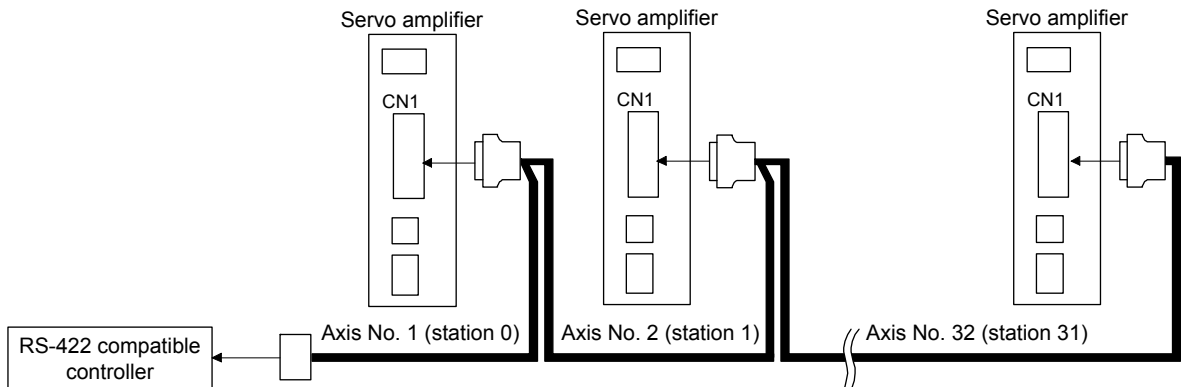

5. HOW TO USE THE PROGRAM

5.5.3 Group specification



CAUTION

- Set only one servo amplifier capable of returning data in a group. If multiple servo amplifiers return data under commands from the controller, the servo amplifiers may malfunction.

When using multiple servo amplifiers, you can set parameters with commands per group.

Up to 6 groups of a to f can be set. Set groups for each station with the communication commands of Mitsubishi general-purpose AC servo protocol.

(1) Group setting example

The following shows a configuration diagram of MR-J4- A_-RJ 100 W or more servo amplifiers.

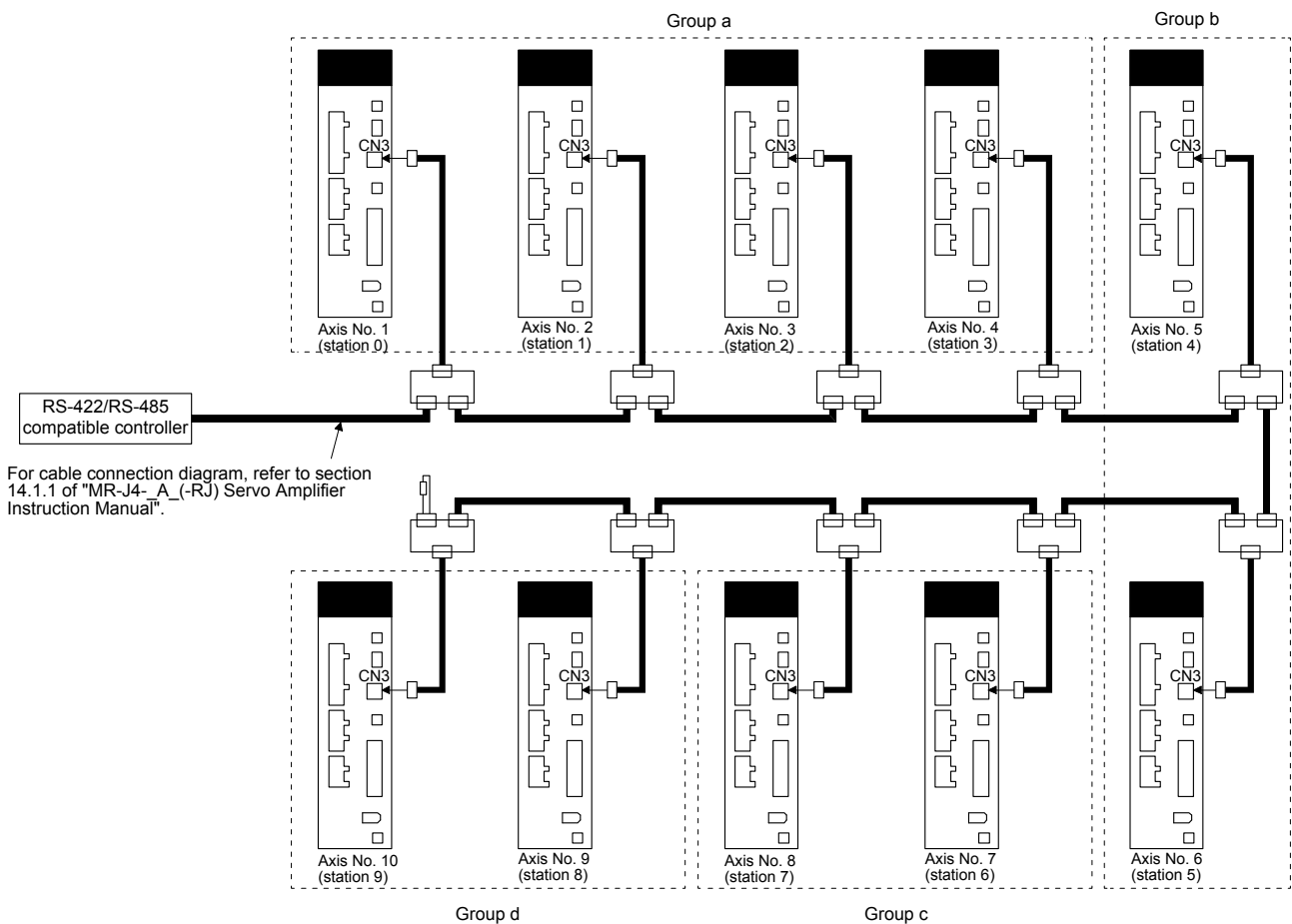

Servo amplifier station No.	Group setting
Station 0	a
Station 1	
Station 2	
Station 3	
Station 4	b
Station 5	
Station 6	c
Station 7	
Station 8	d
Station 9	

5. HOW TO USE THE PROGRAM

(2) Timing chart

The following shows a timing chart of operation for each group performed with setting values set in program No. 1.

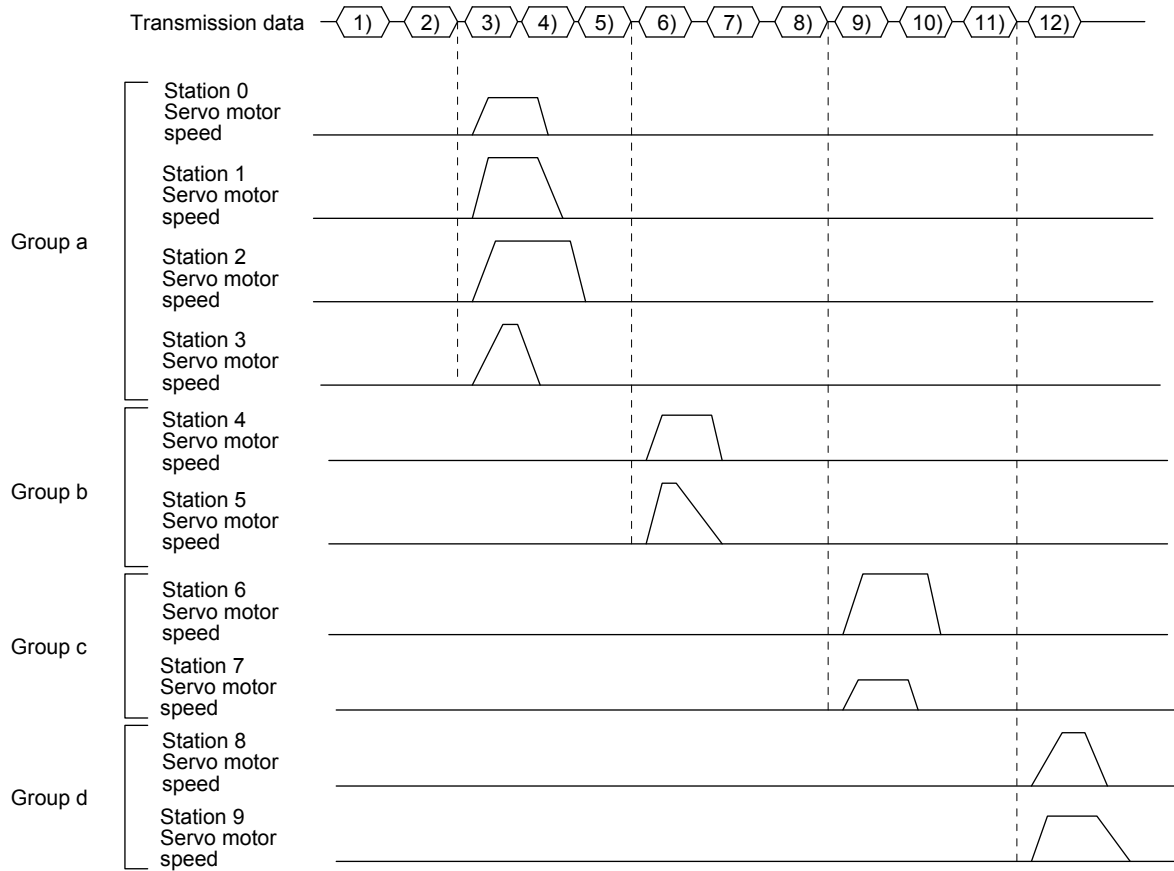

No.	Transmission data description	Command	Data No.
1)	Select Program No. 1 in group a.	[9] [2]	[6] [0]
2)	Switch on ST1 (Forward rotation start).	[9] [2]	[6] [0]
3)	Switch off ST1 (Forward rotation start).	[9] [2]	[6] [0]
4)	Select Program No. 1 in group b.	[9] [2]	[6] [0]
5)	Switch on ST1 (Forward rotation start).	[9] [2]	[6] [0]
6)	Switch off ST1 (Forward rotation start).	[9] [2]	[6] [0]
7)	Select Program No. 1 in group c.	[9] [2]	[6] [0]
8)	Switch on ST1 (Forward rotation start).	[9] [2]	[6] [0]
9)	Switch off ST1 (Forward rotation start).	[9] [2]	[6] [0]
10)	Select Program No. 1 in group d.	[9] [2]	[6] [0]
11)	Switch on ST1 (Forward rotation start).	[9] [2]	[6] [0]
12)	Switch off ST1 (Forward rotation start).	[9] [2]	[6] [0]

Besides this, you can perform simultaneous writing of parameters common to stations of each group, reset alarms, etc.

5. HOW TO USE THE PROGRAM

5.6 Incremental value command method

When using this servo amplifier under the incremental value command method, you must change the setting of [Pr. PT01].

As position data, set the travel distance from the current address to the target address. The incremental value command method enables infinitely long constant rate of feeding.

Setting range: -999999 to 999999 [$\times 10^{\text{STM}}$ μm] (STM = Feed length multiplication [Pr. PT03])
 -999999 to 999999 [$\times 10^{(\text{STM}-4)}$ inch] (STM = Feed length multiplication [Pr. PT03])
 -999999 to 999999 [pulse]

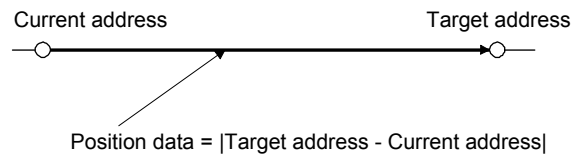

This section indicates contents different from the absolute value command method (factory setting) when this servo amplifier is used under the incremental value command method.

(1) Parameter setting

Set [Pr. PT01] to select the incremental value command method as shown below.

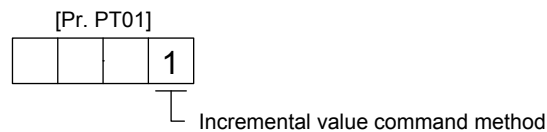

(2) Command

The command contents of "MOV" and "MOVA" are changed as follows. There are no changes in other command. Thus, the command contents are the same between "MOV" and "MOVI", and between "MOVA" and "MOVIA".

Command	Name	Setting	Setting range	Unit	Indirect specification	Description
MOV	Incremental value travel command	MOV (setting value)	-999999 to 999999	$\times 10^{\text{STM}}$ μm	○	The servo motor rotates using the set value as the incremental value. The same as "MOVI" command
MOVA	Incremental value continuous travel command	MOVA (setting value)	-999999 to 999999	$\times 10^{\text{STM}}$ μm	○	The servo motor rotates continuously as the set incremental value. Make sure to describe this command after the "MOV" command. If this command is described after other command, an error will occur. The same as "MOVIA" command

5. HOW TO USE THE PROGRAM

(3) Program example

Command	Description		
SPN (1000)	Servo motor speed	1000 [r/min]	a)
STA (200)	Acceleration time constant	200 [ms]	b)
STB (300)	Deceleration time constant	300 [ms]	c)
MOVI (1000)	Incremental value travel command	1000 [$\times 10^{STM}$ μ m]	d)
TIM (100)	Dwell	100 [ms]	e)
SPN (500)	Servo motor speed	500 [r/min]	f)
STA (200)	Acceleration/deceleration time constant	200 [ms]	g)
STB (300)	Deceleration time constant	300 [ms]	h)
MOVI (1000)	Incremental value travel command	1000 [$\times 10^{STM}$ μ m]	i)
SPN (1000)	Servo motor speed	1000 [r/min]	j)
MOVIA (1000)	Incremental value continuous travel command	1000 [$\times 10^{STM}$ μ m]	k)
STOP	Program stop		

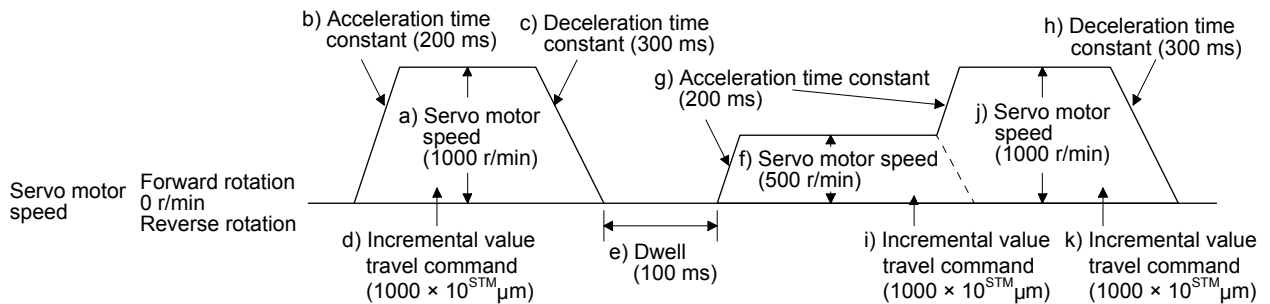

5.7 Roll feed mode using the roll feed display function

Refer to section 4.5 for parameter settings of roll feed display function, position data unit and operation method.

When the roll feed display function is used, the status display of the current position at start will be 0.

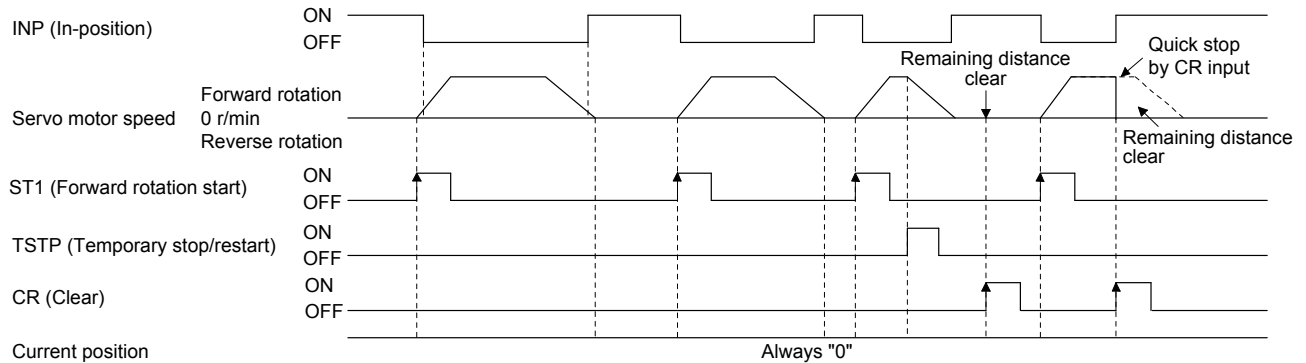

5. HOW TO USE THE PROGRAM

5.8 Program setting method

The following shows the setting method of programs using MR Configurator2.

5.8.1 Setting procedure

Click "Positioning-data" in the menu bar and click "Program" in the menu.

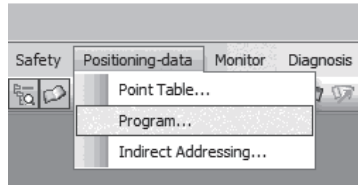

The following window will be displayed by clicking.

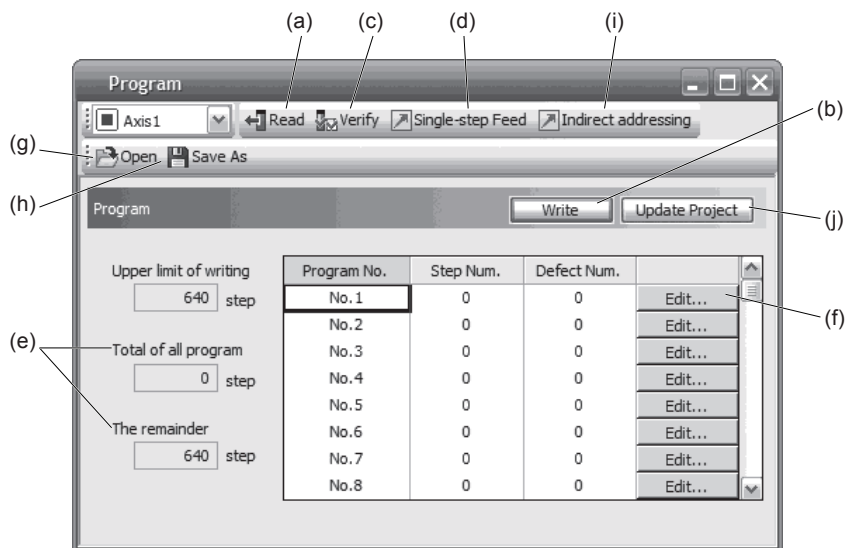

- (1) Reading program (a)
Click "Read" to read and display programs stored in the servo amplifier.
- (2) Writing program (b)
Click "Write" to write the changed programs to the servo amplifier.
- (3) Verifying program (c)
Click "Verify" to verify the contents of programs in the personal computer with contents of programs of the servo amplifier.
- (4) Single-step feed (d)
Click "Single-step Feed" to perform the single-step feed test operation. Refer to section 3.1.9 or 3.2.9 for details.
- (5) Number of steps (e)
Used number of steps in all programs and remained steps are displayed.
- (6) Editing program (f)
You can edit any program. Click "Edit" to open the window for program edit. For the rotation direction, refer to section 5.8.2.

5. HOW TO USE THE PROGRAM

- (7) Reading program file (g)
Click "Open" to read the point table data.
- (8) Saving program file (h)
Click "Save As" to save the program.
- (9) Indirect addressing (i)
Click "Indirect addressing" to open the indirect addressing window. Refer to section 5.8.3 for details.
- (10) Updating project (j)
Click "Update Project" to update the program to a project.

5.8.2 Window for program edit

You can create programs with the window for program edit.

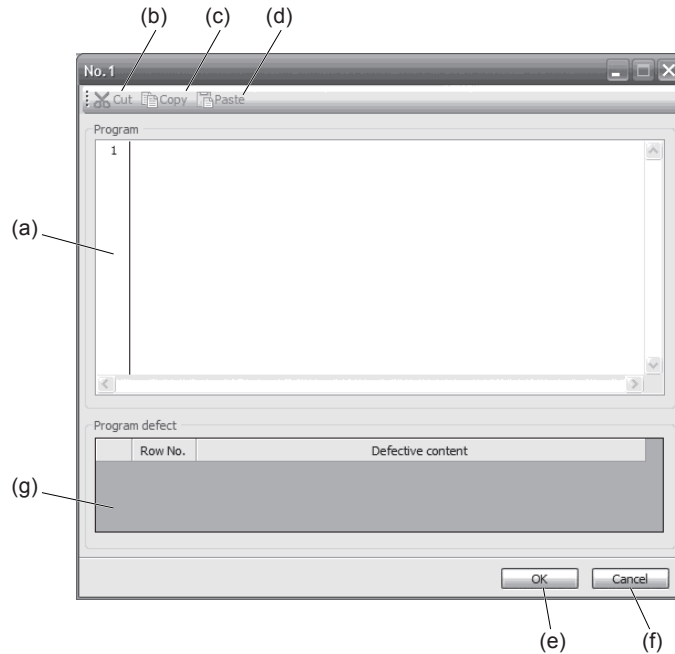

- (1) Program edit (a)
Input commands to the program edit area (a) in text format.
- (2) Cutting text (b)
Select any text of the program edit area and click "Cut" to cut the selected text.
- (3) Copying text (c)
Select any text of the program edit area and click "Copy" to copy the selected text to the clipboard.

5. HOW TO USE THE PROGRAM

(4) Pasting text (d)

Click "Paste" to paste the copied text on the clipboard to a specified place of the program edit area.

(5) Ending window for program (e)

Click "OK" to execute the edit check. When the edit check completes with no error, the edit will finish and the window for program edit will be closed. When the edit check detects an error in the program, it will be displayed.

(6) Canceling window for program edit (f)

Click "Cancel" to close the window for program edit without saving the program currently being edited.

(7) Displaying error (g)

When the edit check of (5) detects an error in the program, the row No. and content of the error will be displayed. Click the error content, the cursor will move to the row of the corresponding program.

5.8.3 Indirect addressing window

Set general purpose registers (D1 to D4 and R1 to R4) in this screen.

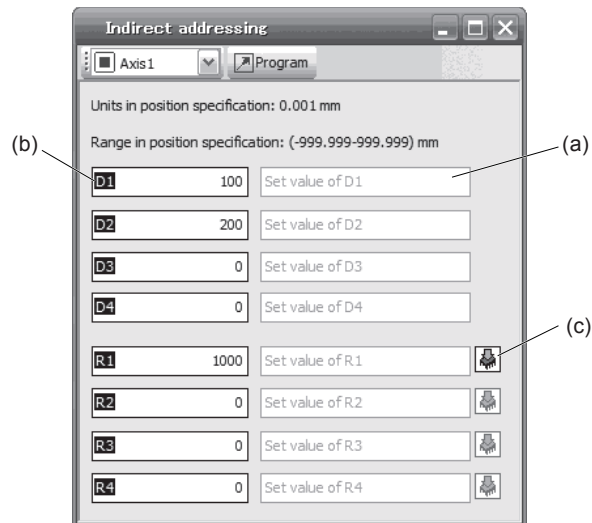

(1) Register edit field (a)

Set general purpose register values of D1 to D4 and R1 to R4.

(2) Register reference field (b)

The last register value read from the servo amplifier is displayed.

(3) ROM writing (c)

You can write register values (D1 to D4 and R1 to R4) stored in the servo amplifier to the servo amplifier.

6. HOW TO USE INDEXER

6. HOW TO USE INDEXER

The following item is the same as that of MR-J4-_A_-RJ servo amplifiers. For details, refer to each section indicated in the detailed explanation field. "MR-J4-_A_" means "MR-J4-_A_(-RJ) Servo Amplifier Instruction Manual".

Item	Detailed explanation	
	MR-J4-_A_-RJ 100 W or more	MR-J4-03A6-RJ
Switching power on for the first time	MR-J4-_A_ section 4.1	MR-J4-_A_ section 18.4

POINT
<ul style="list-style-type: none"> ● In the absolute position detection system, rotating the shaft one revolution or more during power-off may erase a home position. Therefore, do not rotate the shaft one revolution or more during power-off. When a home position is erased, [AL. 90 Home position return incomplete warning] will occur. Then, execute the home position return again. ● The indexer method cannot be used in the fully closed loop system and linear servo system. The combination of the indexer method and fully closed loop system/linear servo system triggers [AL. 37 Parameter error]. ● There are the following restrictions on the number of gear teeth on machine side ([Pr. PA06 Number of gear teeth on machine side]) and the servo motor speed (N). <ul style="list-style-type: none"> ▪ When $CMX \leq 2000$, $N < 3076.7$ r/min ▪ When $CMX > 2000$, $N < (3276.7 - CMX)/10$ r/min When the servo motor is operated at a servo motor speed higher than the limit value, [AL. E3 Absolute position counter warning] will occur.

6. HOW TO USE INDEXER

6.1 Startup

6.1.1 Power on and off procedures

When the servo amplifier is powered on for the first time, the control mode is set to position control mode. (Refer to section 4.2.1 of "MR-J4-_A_(-RJ) Servo Amplifier Instruction Manual".)

This section provides a case where the servo amplifier is powered on after setting the positioning mode.

(1) Power-on

Switch power on in the following procedure. Always follow this procedure at power-on.

- 1) Switch off SON (Servo-on).
- 2) Make sure that ST1 (Forward rotation start) is off.
- 3) Switch on the main circuit power supply and control circuit power supply.

The display shows "C" ("CL" for MR-J4-03A6-RJ servo amplifiers), and in 2 s later, shows data.

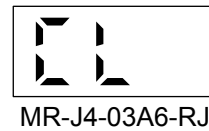
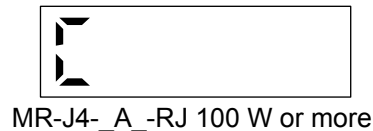

(2) Power-off

- 1) Switch off ST1 (Forward rotation start).
- 2) Switch off SON (Servo-on).
- 3) Switch off the main circuit power supply and control circuit power supply.

6.1.2 Stop

If any of the following situations occurs, the servo amplifier suspends the running of the servo motor and brings it to a stop.

Refer to section 3.10 of "MR-J4-_A_(-RJ) Servo Amplifier Instruction Manual" for the servo motor with an electromagnetic brake.

Operation/command	Stopping condition
Switch off SON (Servo-on).	The base circuit is shut off and the servo motor coasts.
Alarm occurrence	The servo motor decelerates to a stop with the command. With some alarms, however, the dynamic brake operates to bring the servo motor to a stop. (Refer to chapter 8. (Note 1))
EM2 (Forced stop 2) off	The servo motor decelerates to a stop with the command. [AL. E6 Servo forced stop warning] occurs. Refer to section 2.3 for EM1.
STO (STO1, STO2) off (Note 2)	The base circuit is shut off and the dynamic brake operates to bring the servo motor to a stop.
LSP (Forward rotation stroke end) off, LSN (Reverse rotation stroke end) off	It will bring the motor to a sudden stop and make it servo-locked. It can be run in the opposite direction.

Note 1. Only a list of alarms and warnings is listed in chapter 8. Refer to "MELSERVO-J4 Servo Amplifier Instruction Manual (Troubleshooting)" for details of alarms and warnings.

2. MR-J4-03A6-RJ servo amplifiers are not compatible with the STO function.

6. HOW TO USE INDEXER

6.1.3 Test operation

Before starting actual operation, perform test operation to make sure that the machine operates normally. Refer to section 6.1.1 for how to power on and off the servo amplifier.

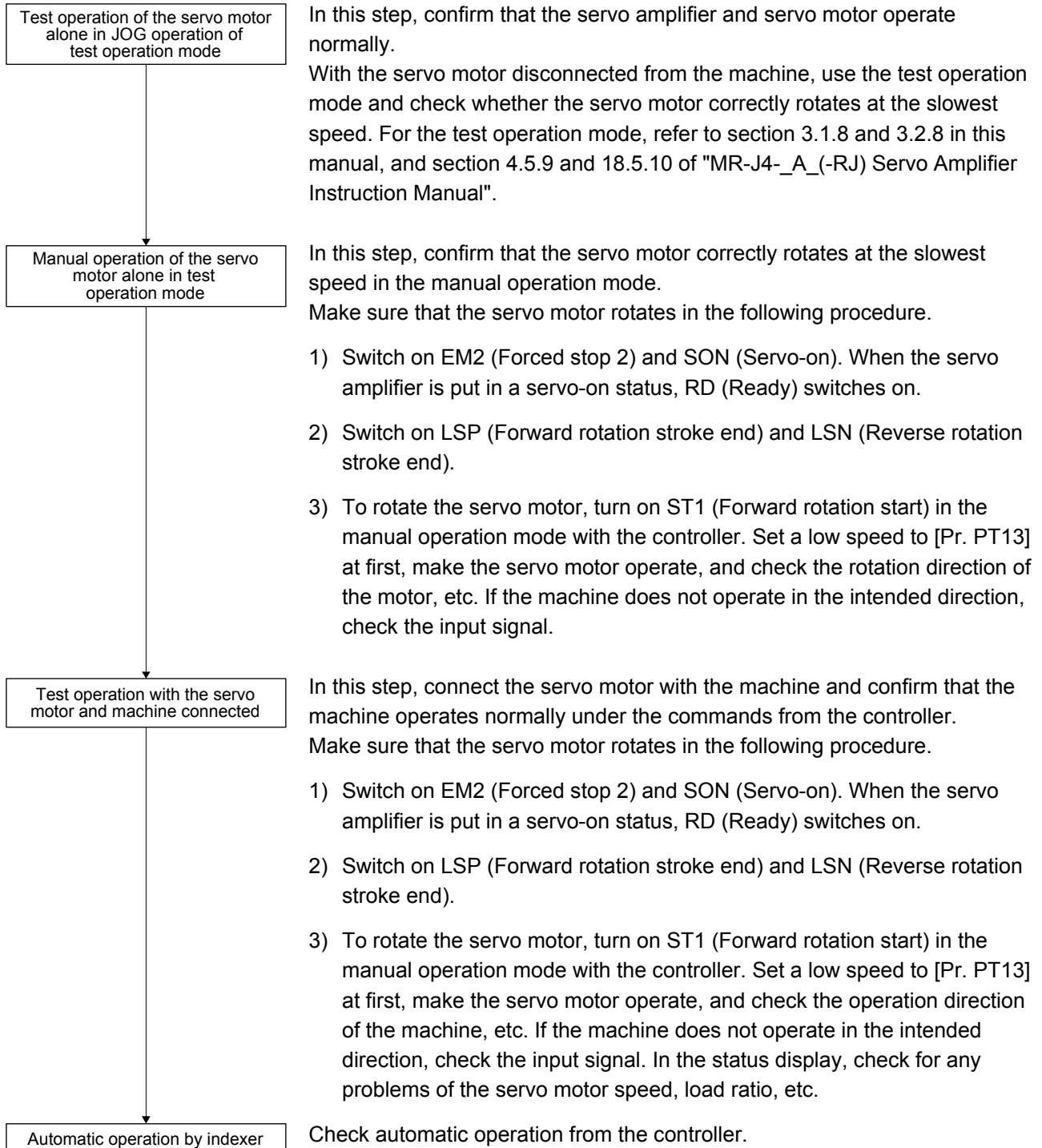

6. HOW TO USE INDEXER

6.1.4 Parameter setting

POINT
<ul style="list-style-type: none"> ● The following encoder cables are of four-wire type. When using any of these encoder cables, set [Pr. PC22] to "1 ___" to select the four-wire type. Incorrect setting will result in [AL. 16 Encoder initial communication error 1]. MR-EKCBL30M-L MR-EKCBL30M-H MR-EKCBL40M-H MR-EKCBL50M-H ● In the indexer method, assign the following input device to CN1-18 pin with [Pr. PD10]. CN1-18: MD1 (Operation mode selection 2) ● Assign the following output devices to the CN1-22, CN1-23, and CN1-25 pins with [Pr. PD23], [Pr. PD24], and [Pr. PD26]. CN1-22: CPO (Rough match) CN1-23: ZP (Home position return completion) CN1-25: MEND (Travel completion)

When using this servo in the indexer method, set [Pr. PA01] to "___8" (Positioning mode (indexer method)). For the indexer method, the servo can be used by merely changing the basic setting parameters ([Pr. PA __]) and positioning control parameters ([Pr. PT __]) mainly.

As necessary, set other parameters.

The following table shows [Pr. PA __] and [Pr. PT __] settings required for the indexer method.

Operation mode selection item		Parameter setting			Input device setting					
		[Pr. PA01]	[Pr. PT04] (Note 2)	[Pr. PT27]	MD0 (Note 1)	MD1 (Note 1, 3)	DI0 to DI7 (Note 1)			
Automatic operation mode	Automatic operation mode 1 (Rotation direction specifying indexer)	___8	/	/	Off	On	Set any next station No. (Refer to section 6.2.2 (3).)			
	Automatic operation mode 2 (Shortest rotating indexer)				On	On				
Manual operation mode	Station JOG operation				___0_	On	Off	Any		
	JOG operation				___1_					
Home position return mode	Dog type/Torque limit changing dog type				___0	/	/	Off	Off	Any
	Data set type/torque limit changing data set type				___2					

Note 1. MD0: Operation mode selection 1, MD1: Operation mode selection 2, DI0 to DI7: Next station No. selection 1 to 8

2. Setting other than "___0" and "___2" will trigger [AL. 37 Parameter error].

3. In the indexer method, assign the following input device to CN1-18 pin with [Pr. PD10].

CN1-18: MD1 (Operation mode selection 2)

6. HOW TO USE INDEXER

6.1.5 Actual operation

Start actual operation after confirmation of normal operation by test operation and completion of the corresponding parameter settings.

6.1.6 Troubleshooting at start-up



CAUTION ● Never make a drastic adjustment or change to the parameter values as doing so will make the operation unstable.

POINT

● Using MR Configurator2, you can refer to reason for rotation failure, etc.

The following faults may occur at start-up. If any of such faults occurs, take the corresponding action. "MR-J4- _A_" means "MR-J4- _A_(-RJ) Servo Amplifier Instruction Manual".

No.	Start-up sequence	Fault	Investigation	Possible cause	Reference
1	Power on	<ul style="list-style-type: none"> • The 7-segment LED display does not turn on. • The 7-segment LED display flickers. 	Not improved even if CN1, CN2, and CN3 connectors are disconnected.	<ol style="list-style-type: none"> 1. Power supply voltage fault 2. The servo amplifier is malfunctioning. 	/
			Improved when CN1 connector is disconnected.	Power supply of CN1 cabling is shorted.	
			Improved when CN2 connector is disconnected.	<ol style="list-style-type: none"> 1. Power supply of encoder cabling is shorted. 2. Encoder is malfunctioning. 	
			Improved when CN3 connector is disconnected.	Power supply of CN3 cabling is shorted.	
		Alarm occurs.	Refer to chapter 8 and remove the cause.		Chapter 8 (Note)
2	Switch on SON (Servo-on).	Alarm occurs.	Refer to chapter 8 and remove the cause.		Chapter 8 (Note)
		Servo motor shaft is not servo-locked. (Servo motor shaft is free.)	<ol style="list-style-type: none"> 1. Check the display to see if the servo amplifier is ready to operate. 2. Check the external I/O signal indication (section 3.1.7 or 3.2.7) to see if SON (Servo-on) is on. 	<ol style="list-style-type: none"> 1. SON (Servo-on) is not input. (wiring mistake) 2. 24 V DC power is not supplied to DICOM. 	Section 3.1.7 Section 3.2.7
3	Perform a home position return.	Servo motor does not rotate.	Call the external I/O signal display and check the on/off status of the input signal. (Refer to section 3.1.7 or 3.2.7.)	LSP, LSN, and ST1 are off.	Section 3.1.7 Section 3.2.7
			Check [Pr. PA11 Forward rotation torque limit] and [Pr. PA12 Reverse rotation torque limit].	Torque limit level is too low as compared to the load torque.	Section 7.2.1
			When TLA (Analog torque limit) is usable, check the input voltage on the status display.	Torque limit level is too low as compared to the load torque.	Section 3.1.2 Section 3.2.2
		The home position return is not completed.	Call the external I/O signal display and check the on/off status of DOG. (Refer to section 3.1.7 or 3.2.7.)	The proximity dog is set incorrectly.	Section 3.1.7 Section 3.2.7

6. HOW TO USE INDEXER

No.	Start-up sequence	Fault	Investigation	Possible cause	Reference
4	Switch on ST1 (Forward rotation start).	Servo motor does not rotate.	Call the external I/O signal display (Section 3.1.7 or 3.2.7) and check the on/off status of the input signal.	LSP, LSN, and ST1 are off.	Section 3.1.7 Section 3.2.7
			Check [Pr. PA11 Forward rotation torque limit] and [Pr. PA12 Reverse rotation torque limit].	Torque limit level is too low as compared to the load torque.	Section 7.2.1
			When TLA (Analog torque limit) is usable, check the input voltage on the status display.	Torque limit level is too low as compared to the load torque.	Section 3.1.2 Section 3.2.2
5	Gain adjustment	Rotation ripples (speed fluctuations) are large at low speed.	Make gain adjustment in the following procedure. 1. Increase the auto tuning response level. 2. Repeat acceleration/ deceleration more than three times to complete auto tuning.	Gain adjustment fault	MR-J4- _A_ Chapter 6
		Large load inertia moment causes the servo motor shaft to oscillate side to side.	If the servo motor may be driven with safety, repeat acceleration and deceleration three times or more to complete the auto tuning.	Gain adjustment fault	MR-J4- _A_ Chapter 6

Note. Only a list of alarms and warnings is listed in chapter 8. Refer to "MELSERVO-J4 Servo Amplifier Instruction Manual (Troubleshooting)" for details of alarms and warnings.

6. HOW TO USE INDEXER

6.2 Automatic operation mode

POINT
<ul style="list-style-type: none"> ● There are the following conditions between the number of gear teeth on machine side ([Pr. PA06 Number of gear teeth on machine side]) and servo motor speed (N). <ul style="list-style-type: none"> ▪ When $CMX \leq 2000$, $N < 3076.7 \text{ r/min}$ ▪ When $CMX > 2000$, $N < 3276.7 - CMX \text{ r/min}$ When the servo motor is operated at servo motor speed higher than the limit value, [AL. E3 Absolute position counter warning] occurs. ● When the same next station No. is specified as station No. of the current position and a positioning operation is executed, the motor does not start because the travel distance is decided as "0".

6.2.1 Automatic operation mode

(1) Logic of indexer

The positioning is executed like this. A station, which one of the divided circumference (360 degrees) into 255 at most on the machine side, is selected by using 8-bit devices of the DI0 (Next station No. selection 1) to DI7 (Next station No. selection 8). The following diagram is an example for when [Pr. PA14] is set to "0".

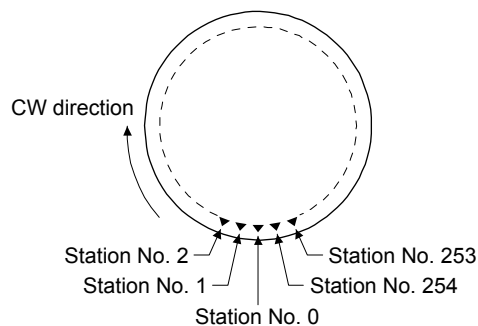

The station No. 0 is set as a home position. The number of divisions is set with [Pr. PT28].

(2) Rotation direction

There are two operation methods: Rotation direction specifying indexer, which always rotates in a fixed direction and execute positioning to a station; Shortest rotating indexer, which automatically changes a rotation direction to the shortest distance and execute positioning to a station

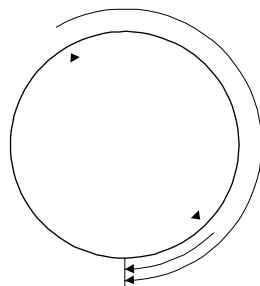

Rotation direction specifying indexer

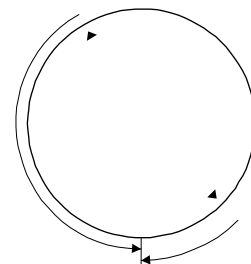

Shortest rotating indexer

6. HOW TO USE INDEXER

6.2.2 Automatic operation mode 1 (rotation direction specifying indexer)

In this operation mode, the servo motor rotates in a fixed direction to execute positioning to a station. The positioning is executed by selecting a station No. using 8-bit devices of the DI0 (Next station No. selection 1) to DI7 (Next station No. selection 8). For the servo motor speed and acceleration/deceleration time constant during operation, the values set in the point tables are used.

(1) Device/parameter

Set input devices and parameters as follows.

Item	Used device/parameter	Setting
Selecting indexer method	Control mode selection of [Pr. PA01]	Select " _ _ _ 8" (positioning mode (indexer method)).
Next station position	DI0 (Next station No. selection 1) to DI7 (Next station No. selection 8)	Set any next station No. (Refer to (3) of this section.)
Selecting automatic operation mode 1 (rotation direction specifying indexer)	MD0 (Operation mode selection 1)	Switch off MD0.
	MD1 (Operation mode selection 2)	Switch on MD1.
Rotation direction selection	SIG (External limit/Rotation direction decision/Automatic speed selection)	The rotation direction to a station No. will be as follows. Off: Station No. decreasing direction On: Station No. increasing direction
Servo motor speed	[Pr. PC05]	Set a servo motor speed.
Acceleration time constant/Deceleration time constant	RT (Second acceleration/deceleration selection)	1. When RT is turned off Acceleration time constant: setting value of [Pr. PC01 Acceleration time constant 1] Deceleration time constant: setting value of [Pr. PC02 Deceleration time constant 1] 2. When RT is turned on Acceleration time constant: setting value of [Pr. PC30 Acceleration time constant 2] Deceleration time constant: setting value of [Pr. PC31 Deceleration time constant 2]
Torque limit (Note)	[Pr. PA11] [Pr. PA12]	Set a torque limit value for during operation.
	[Pr. PC35]	Set a torque limit value for during stop.
	[Pr. PT39]	Set time to switch the torque limit value from during operation until during stop.

Note. The torque limit will change from [Pr. PC35 Internal torque limit 2] to the setting value of [Pr. PA11 Forward rotation torque limit] or [Pr. PA12 Reverse rotation torque limit] when ST1 (Forward rotation start) is inputted. After MEND (Travel completion) is outputted, the time has passed set with [Pr. PT39] and the torque limit will change from [Pr. PA11 Forward rotation torque limit] or [Pr. PA12 Reverse rotation torque limit] to the setting value of [Pr. PC35 Internal torque limit 2].

6. HOW TO USE INDEXER

(2) Other parameter settings

(a) Setting assignment direction of station No.

Select an assignment direction of station No. with [Pr. PA14].

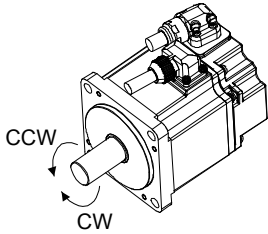

[Pr. PA14] setting	Servo motor rotation direction ST1 (Forward rotation start) is on.
0	Next station No. will be assigned in CW direction in order of 1, 2, 3...
1	Next station No. will be assigned in CCW direction in order of 1, 2, 3...

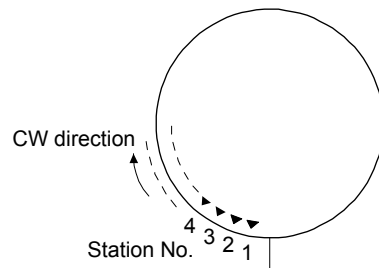

[Pr. PA14]: 0 (initial value)

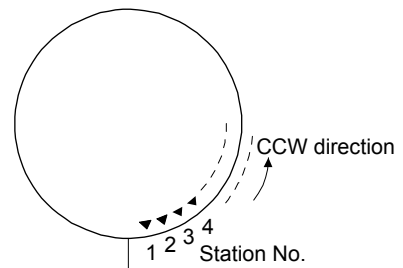

[Pr. PA14]: 1

(b) Setting number of stations

Set a number of stations to [Pr. PT28].

	[Pr. PT28] setting				
Number of stations	2	3	4	...	255
Station No.				...	

6. HOW TO USE INDEXER

(3) Operation

Select a target station No. using 8-bit devices of the DI0 (Next station No. selection 1) to DI7 (Next station No. selection 8) for positioning.

Device (Note 1)								Selection contents
DI7	DI6	DI5	DI4	DI3	DI2	DI1	DI0	
0	0	0	0	0	0	0	0	Next station No. 0
0	0	0	0	0	0	0	1	Next station No. 1
0	0	0	0	0	0	1	0	Next station No. 2
0	0	0	0	0	0	1	1	Next station No. 3
.
.
.
1	1	1	1	1	1	1	0	Next station No. 254
1	1	1	1	1	1	1	1	Setting inhibited (Note 2)

Note 1. 0: Off
1: On

2. [AL. 97.2 Next station position warning] will occur.

(4) Timing chart

POINT
<ul style="list-style-type: none"> ● Always perform a home position return. Executing positioning operation without home position return will trigger [AL. 90 Home position return incomplete warning] and ST1 (Forward rotation start) will be disabled. ● When a next station position is over the setting value of [Pr. PT28 Number of stations per rotation], [AL. 97 Next station position warning] will occur and ST1 (Forward rotation start) will be disabled.

6. HOW TO USE INDEXER

The following timing chart shows that an operation is performed at a stop of the station No. 0 when servo-on.

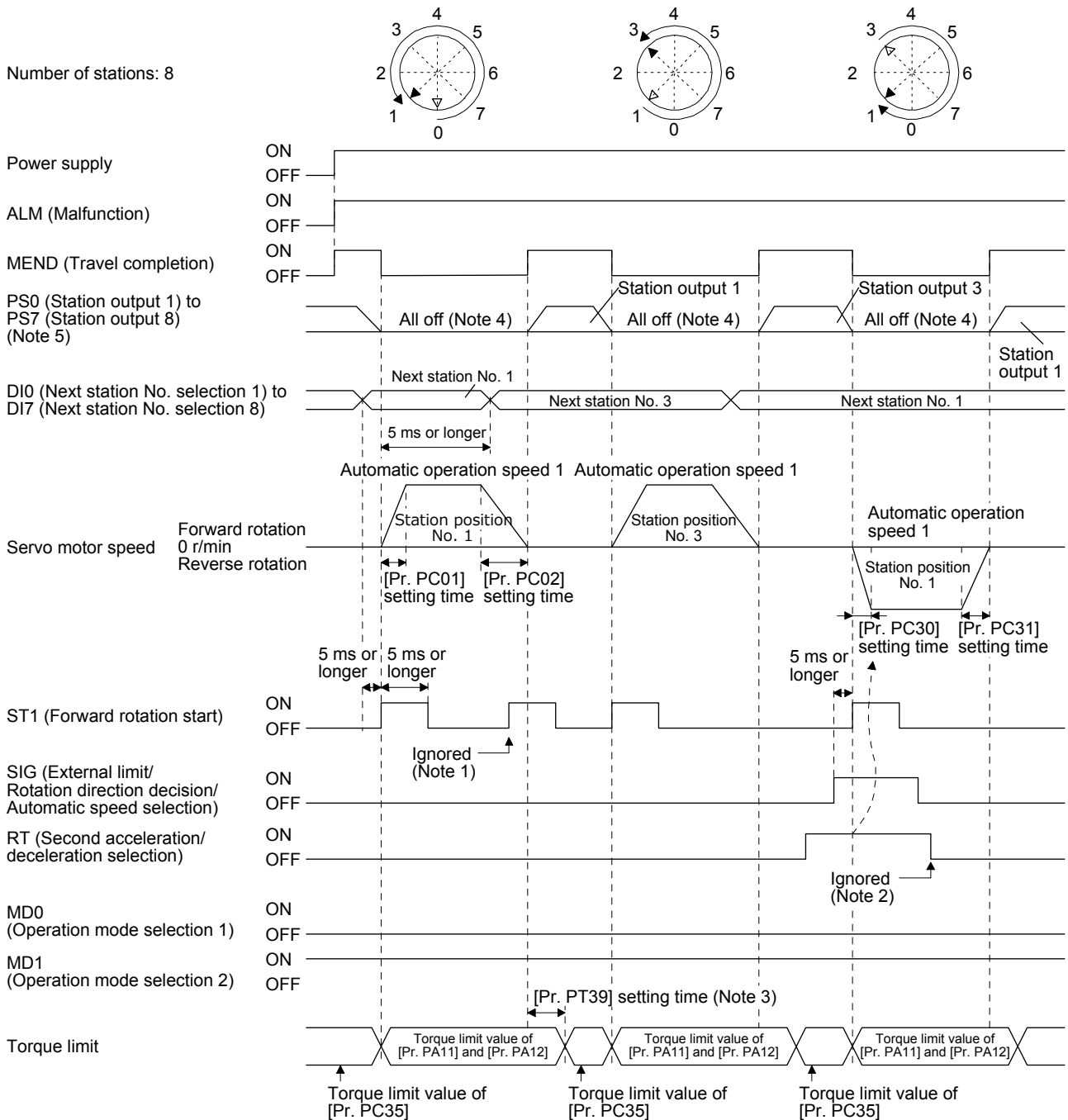

- Note
1. When the rest of command travel distance is other than "0", ST1 (Forward rotation start) will not be accepted. Refer to section 6.4.5 (1).
 2. RT (Second acceleration/deceleration selection) will not be accepted during operation. Selection of the servo motor speed and acceleration/deceleration time constants will be enabled by on-edge of ST1 (Forward rotation start). However, when the rest of command travel distance is other than "0", turning on ST1 (Forward rotation start) will not be enabled.
 3. Counting will start when the rest of command travel distance becomes "0".
 4. When MEND (Travel completion) is off, the station position outputs will be "0" (all off).
 5. For MR-J4-03A6-RJ servo amplifiers, up to six points of DO are available; therefore, PS0 to PS7 cannot be outputted simultaneously.

6. HOW TO USE INDEXER

6.2.3 Automatic operation mode 2 (shortest rotating indexer)

This operation mode automatically changes a rotation direction to the shortest distance to execute positioning to a station.

The positioning is executed by selecting a station No. using 8-bit devices of the DI0 (Next station No. selection 1) to DI7 (Next station No. selection 8). For the servo motor speed and acceleration/deceleration time constant during operation, the values set in the point tables are used.

(1) Device/parameter

Set input devices and parameters as follows.

Item	Used device/parameter	Setting
Selecting indexer method	Control mode selection of [Pr. PA01]	Select " _ _ _ 8" (positioning mode (indexer method)).
Next station position	DI0 (Next station No. selection 1) to DI7 (Next station No. selection 8)	Set any next station No. (Refer to (3) of this section.)
Automatic operation mode 2 (shortest rotating indexer) selection	MD0 (Operation mode selection 1)	Switch on MD0.
	MD1 (Operation mode selection 2)	Switch on MD1.
Servo motor speed	SIG (External limit/Rotation direction decision/Automatic speed selection)	The servo motor speed will be as follows. Off: setting value of [Pr. PC05 Automatic operation speed 1] On: setting value of [Pr. PC06 Automatic operation speed 2]
Acceleration time constant/Deceleration time constant	RT (Second acceleration/deceleration selection)	1. When RT is turned off Acceleration time constant: setting value of [Pr. PC01 Acceleration time constant 1] Deceleration time constant: setting value of [Pr. PC02 Deceleration time constant 1] 2. When RT is turned on Acceleration time constant: setting value of [Pr. PC30 Acceleration time constant 2] Deceleration time constant: setting value of [Pr. PC31 Deceleration time constant 2]

(2) The other parameter setting (number of stations)

Set a number of stations to [Pr. PT28]. The setting is the same as that of automatic operation mode 1. Refer to section 6.2.2 (2) (b).

[Pr. PA14 Rotation direction selection] is not used in the automatic operation mode 2.

6. HOW TO USE INDEXER

(3) Operation

Select a target station No. using 8-bit devices of the DI0 (Next station No. selection 1) to DI7 (Next station No. selection 8) for positioning.

Device (Note 1)								Selection contents
DI7	DI6	DI5	DI4	DI3	DI2	DI1	DI0	
0	0	0	0	0	0	0	0	Next station No. 0
0	0	0	0	0	0	0	1	Next station No. 1
0	0	0	0	0	0	1	0	Next station No. 2
0	0	0	0	0	0	1	1	Next station No. 3
.
.
.
1	1	1	1	1	1	1	0	Next station No. 254
1	1	1	1	1	1	1	1	Setting inhibited (Note 2)

Note 1. 0: Off
1: On

2. [AL. 97.2 Next station position warning] will occur.

6. HOW TO USE INDEXER

(4) Timing chart

POINT
<ul style="list-style-type: none"> ● Always perform a home position return. Executing positioning operation without home position return will trigger [AL. 90 Home position return incomplete warning] and ST1 (Forward rotation start) will be disabled. ● When travel distances are the same to a target station position from CCW and from CW, the shaft will rotate to the station No. increasing direction.

The following timing chart shows that an operation is performed at a stop of the station No. 0 when servo-on.

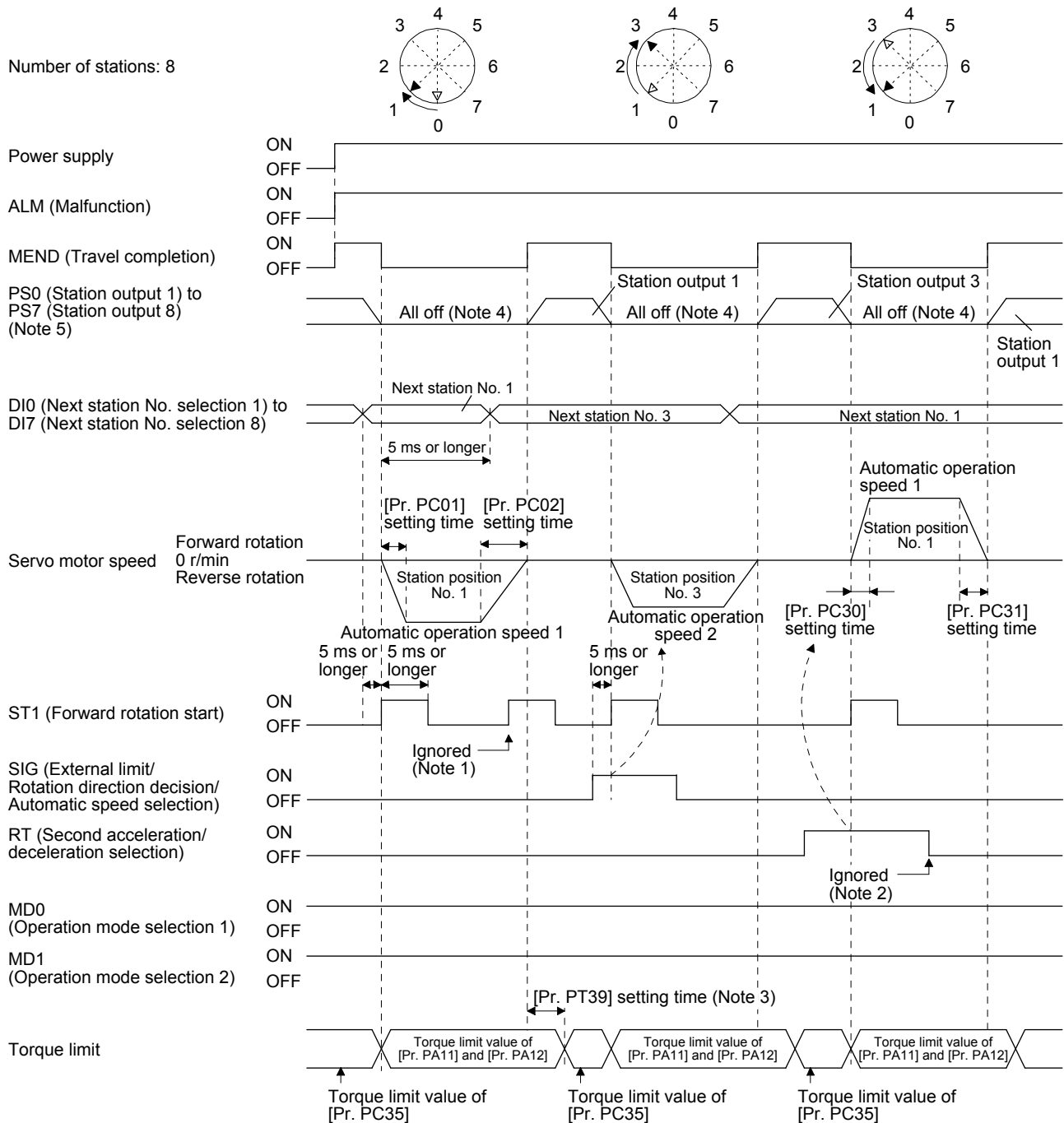

6. HOW TO USE INDEXER

- Note
1. When the rest of command travel distance is other than "0", ST1 (Forward rotation start) will not be accepted. Refer to section 6.4.5 (1).
 2. RT (Second acceleration/deceleration selection) will not be accepted during operation. Selection of the servo motor speed and acceleration/deceleration time constants will be enabled by on-edge of ST1 (Forward rotation start). However, when the rest of command travel distance is other than "0", turning on ST1 (Forward rotation start) will not be enabled.
 3. Counting will start when the rest of command travel distance becomes "0".
 4. When MEND (Travel completion) is off, the station position outputs will be "0" (all off).
 5. For MR-J4-03A6-RJ servo amplifiers, up to six points of DO are available; therefore, PS0 to PS7 cannot be outputted simultaneously.

6.3 Manual operation mode

POINT
<p>● When the operation mode is changed during operation, inputting ST1 (Forward rotation start) is disabled until the operation stops. Switch on ST1 (Forward rotation start) after the operation stops.</p>

For the machine adjustment, home position adjustment, and others, you can shift the position to any position with the station JOG operation or JOG operation.

6.3.1 Station JOG operation

(1) Setting

According to the purpose of use, set devices and parameters as shown below. With this operation, DI0 (Next station No. selection 1) to DI7 (Next station No. selection 8) are disabled.

Item	Used device/parameter	Setting
Selecting indexer method	Control mode selection of [Pr. PA01]	Select "_ _ _ 8" (positioning mode (indexer method)).
Manual operation mode selection	MD0 (Operation mode selection 1)	Switch on MD0.
	MD1 (Operation mode selection 2)	Switch off MD1.
Station JOG operation selection	[Pr. PT27]	Select "_ _ 0 _" (Station JOG operation).
Rotation direction selection	SIG (External limit/Rotation direction decision/Automatic speed selection)	The rotation direction to a station No. will be as follows. Off: Station No. decreasing direction On: Station No. increasing direction
Servo motor speed	[Pr. PC07]	Set a servo motor speed.
Acceleration time constant/Deceleration time constant	RT (Second acceleration/deceleration selection)	1. When RT is turned off Acceleration time constant: setting value of [Pr. PC01 Acceleration time constant 1] Deceleration time constant: setting value of [Pr. PC02 Deceleration time constant 1] 2. When RT is turned on Acceleration time constant: setting value of [Pr. PC30 Acceleration time constant 2] Deceleration time constant: setting value of [Pr. PC31 Deceleration time constant 2]

6. HOW TO USE INDEXER

(2) Setting assignment direction of station No.

Select an assignment direction of station No. with [Pr. PA14].

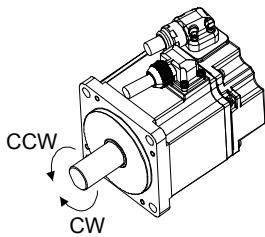

[Pr. PA14] setting	Servo motor rotation direction ST1 (Forward rotation start) is on.
0	Next station No. will be assigned in CW direction in order of 1, 2, 3...
1	Next station No. will be assigned in CCW direction in order of 1, 2, 3...

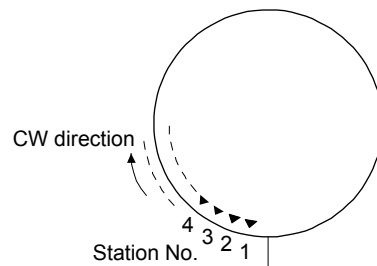

[Pr. PA14]: 0 (initial value)

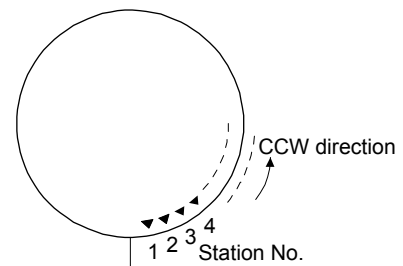

[Pr. PA14]: 1

(3) Operation

Turning on ST1 (Forward rotation start) will start rotation to a direction specified with the rotation direction decision and turning off it will execute a positioning to the closest station position which is possible to decelerate to a stop. However, the shaft stops based on a set time constant depending on the setting value of deceleration time constant. The speed may not reach the specified speed.

6. HOW TO USE INDEXER

(4) Timing chart

The following timing chart shows that a JOG operation is performed at a stop of the station No. 0 when servo-on.

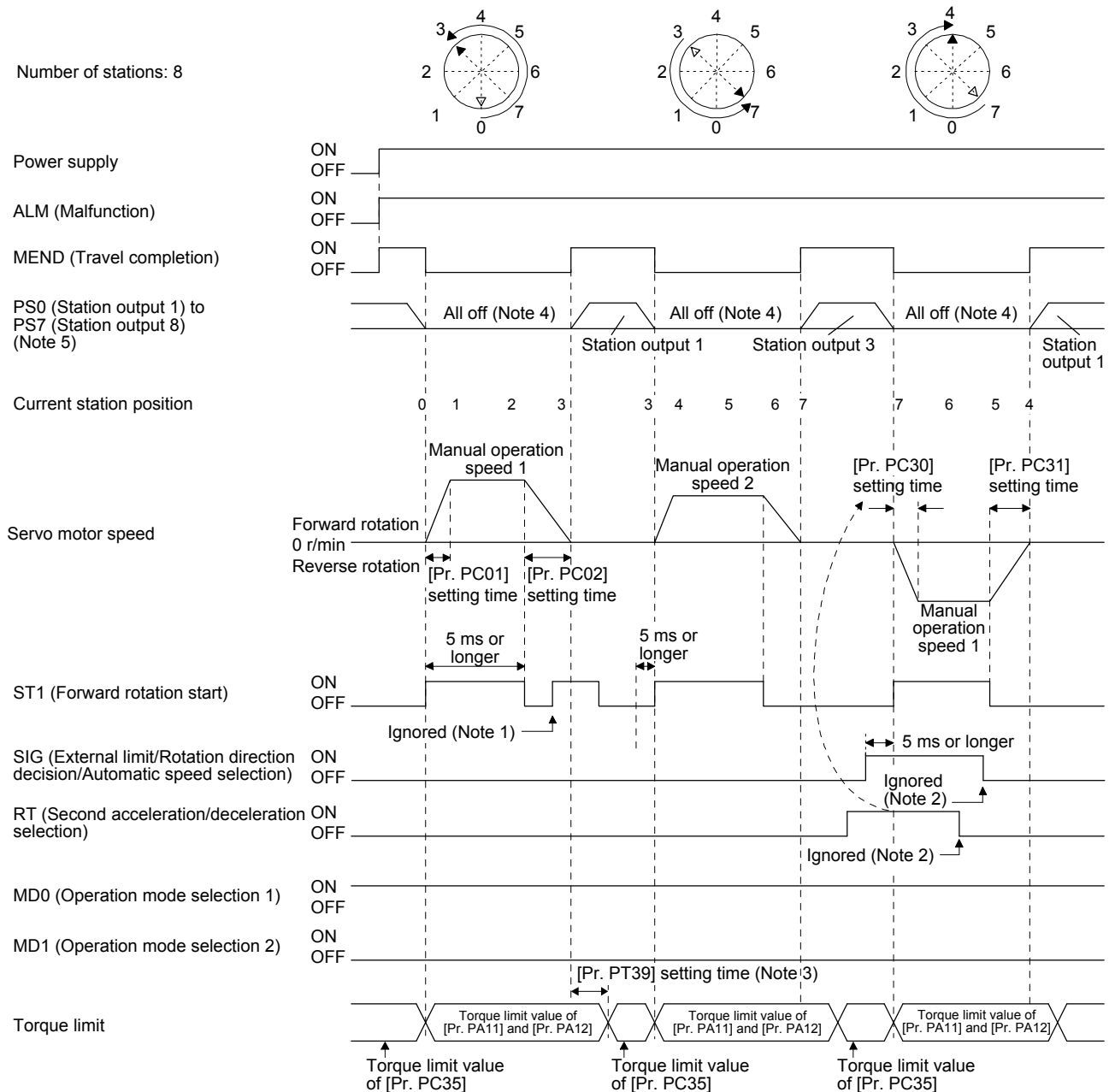

- Note 1. When the rest of command travel distance is other than "0", ST1 (Forward rotation start) will not be accepted. Refer to section 6.4.5 (1).
- Note 2. SIG and RT (Second acceleration/deceleration selection) will not be accepted during operation. Selection of the servo motor speed and acceleration/deceleration time constants will be enabled by on-edge of ST1 (Forward rotation start). However, when the rest of command travel distance is other than "0", turning on ST1 (Forward rotation start) will not be enabled.
- Note 3. Counting will start when the rest of command travel distance becomes "0".
- Note 4. When MEND (Travel completion) is off, the station position outputs will be "0" (all off).
- Note 5. For MR-J4-03A6-RJ servo amplifiers, up to six points of DO are available; therefore, PS0 to PS7 cannot be outputted simultaneously.

6. HOW TO USE INDEXER

6.3.2 JOG operation

(1) Setting

According to the purpose of use, set devices and parameters as shown below. With this operation, D10 (Next station No. selection 1) to D17 (Next station No. selection 8) are disabled.

Item	Used device/parameter	Setting
Selecting indexer method	Control mode selection of [Pr. PA01]	Select " _ _ _ 8" (positioning mode (indexer method)).
Manual operation mode selection	MD0 (Operation mode selection 1)	Switch on MD0.
	MD1 (Operation mode selection 2)	Switch off MD1.
JOG operation selection	[Pr. PT27]	Select " _ _ 1 _" (JOG operation).
Rotation direction selection	SIG (External limit/Rotation direction decision/Automatic speed selection)	The rotation direction to a station No. will be as follows. Off: Station No. decreasing direction On: Station No. increasing direction
Servo motor speed	[Pr. PC07]	Set a servo motor speed.
Acceleration time constant/Deceleration time constant	RT (Second acceleration/deceleration selection)	1. When RT is turned off Acceleration time constant: setting value of [Pr. PC01 Acceleration time constant 1] Deceleration time constant: setting value of [Pr. PC02 Deceleration time constant 1] 2. When RT is turned on Acceleration time constant: setting value of [Pr. PC30 Acceleration time constant 2] Deceleration time constant: setting value of [Pr. PC31 Deceleration time constant 2]

(2) Operation

Turning on ST1 (Forward rotation start) will start rotation to a direction specified with the rotation direction decision and turning off it will decelerate to a stop regardless of the station position.

6. HOW TO USE INDEXER

(3) Timing chart

The following timing chart shows that a JOG operation is performed at a stop of the station No. 0 when servo-on.

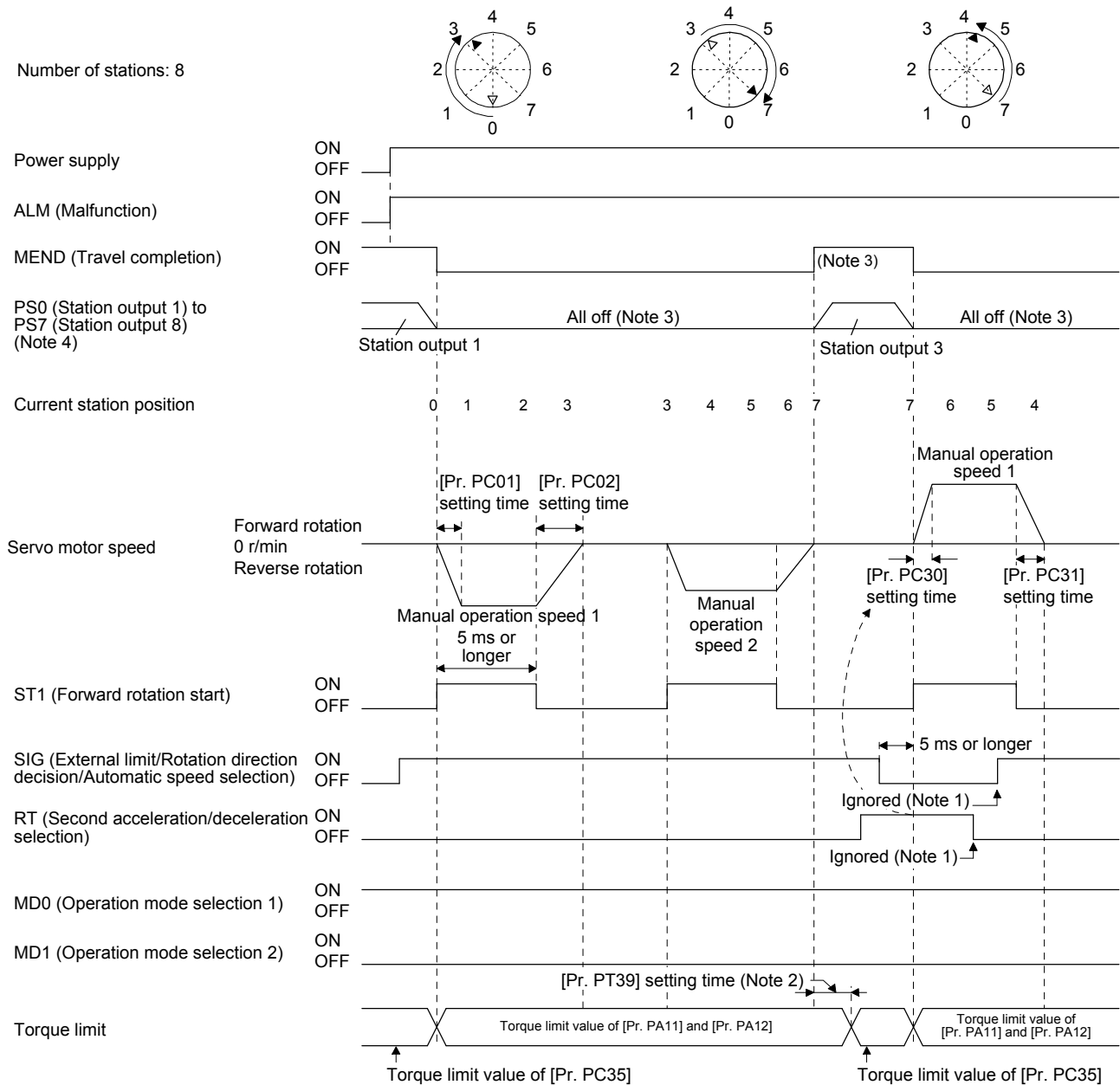

- Note 1. SIG and RT (Second acceleration/deceleration selection) will not be accepted during operation. Selection of the servo motor speed and acceleration/deceleration time constants will be enabled by on-edge of ST1 (Forward rotation start). However, when the rest of command travel distance is other than "0", turning on ST1 (Forward rotation start) will not be enabled.
- Note 2. Counting will start when the rest of command travel distance becomes "0".
- Note 3. MEND (Travel completion) is off because the shaft does not stop within the in-position range of each next station position. When MEND (Travel completion) turns off, PS0 (Station output 1) to PS7 (Station output 8) will not be outputted. Additionally, the station position outputs will be "0" (all off) during home position return incompletion.
- Note 4. For MR-J4-03A6-RJ servo amplifiers, up to six points of DO are available; therefore, PS0 to PS7 cannot be outputted simultaneously.

6. HOW TO USE INDEXER

6.4 Home position return mode

POINT
<ul style="list-style-type: none"> ● Before performing the home position return, make sure that the limit switch operates. ● Check the home position return direction. An incorrect setting will cause a reverse running. ● Check the input polarity of the external limit. Otherwise, it may cause an unexpected operation. ● In the following cases, make sure that the Z-phase has been passed through once before performing a home position return. <ul style="list-style-type: none"> ▪ When a servo amplifier is used in the DD motor control mode Z-phase unpassed will trigger [AL. 90.5 Home position return incomplete warning]. ● For precautions for using linear servo motors or fully closed loop system, refer to section 4.4.15 and 4.4.16.

6.4.1 Outline of home position return

A home position return is performed to match the command coordinates with the machine coordinates. Under the incremental method, each power-on of the input power supply requires the home position return. Contrastingly, in the absolute position detection system, once you have performed the home position return at machine installation, the current position will be retained even if the power supply is shut off. Therefore, the home position return is unnecessary when the power supply is switched on again. This section shows the home position return methods of the servo amplifier. Select the optimum method according to the configuration and uses of the machine.

(1) Home position return types

Select the optimum home position return type according to the machine type or others.

System	Home position return method	Feature
Torque limit changing dog type	Deceleration starts at the external limit detection. The position specified by the first Z-phase signal, or the position of the first Z-phase signal shifted by the home position shift distance is used as the home position.	<ul style="list-style-type: none"> ▪ This is a typical home position return method using an external limit. ▪ The repeatability of the home position return is high. ▪ The machine is less loaded. ▪ Used when the width of the external limit can be set equal to or greater than the deceleration distance of the servo motor.
Torque limit changing data set type	An arbitrary position is used as the home position.	<ul style="list-style-type: none"> ▪ An external limit is not required.

6. HOW TO USE INDEXER

(2) Parameters for home position return

To perform the home position return, set each parameter as follows.

(a) Select the home position return type with [Pr. PT04 Home position return type].

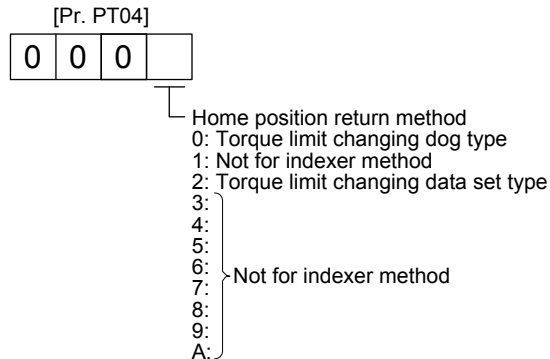

(b) Select the starting direction for the home position return with [Pr. PT04 Home position return type].

Setting "0" starts the home position return in the address increasing direction from the current position. Setting "1" starts the home position return in the address decreasing direction from the current position.

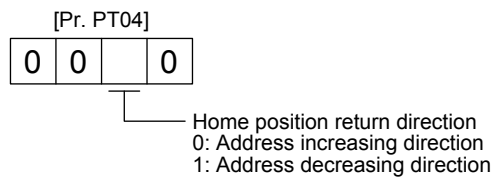

(c) Select the polarity where the external limit is detected with the SIG polarity selection of [Pr. PT29 Function selection T-3].

Setting "0" is for detection with normally open contact and setting "1" is for detection with normally closed contact.

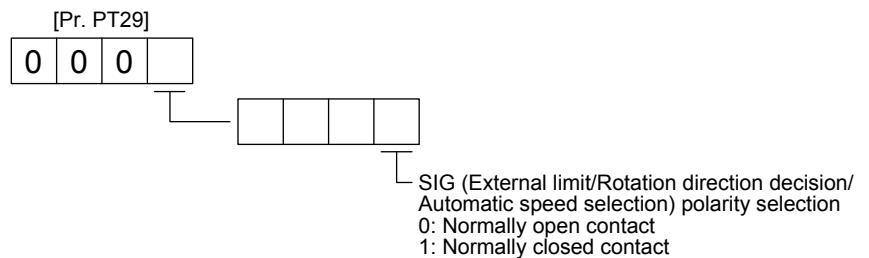

6. HOW TO USE INDEXER

6.4.2 Torque limit changing dog type home position return

This is a home position return method using an external limit. Deceleration starts at the external limit detection. The position specified by the first Z-phase signal, or the position of the first Z-phase signal shifted by the specified home position shift distance is used as the home position.

(1) Device/parameter

Set input devices and parameters as follows.

Item	Used device/parameter	Setting
Home position return mode selection	MD0 (Operation mode selection 1)	Switch off MD0.
	MD1 (Operation mode selection 2)	Switch off MD1.
Torque limit changing dog type home position return	[Pr. PT04]	Select "_ _ _ 0" (Torque limit changing dog type).
Home position return speed	[Pr. PT05]	Set the rotation speed specified until an external limit is detected.
Creep speed	[Pr. PT06]	Set the rotation speed specified after an external limit is detected.
Home position shift distance	[Pr. PT07]	Set this item to shift the home position, which is specified by the first Z-phase signal after the external limit is detected.
Acceleration time constant/Deceleration time constant	RT (Second acceleration/deceleration selection)	1. When RT is turned off Acceleration time constant: setting value of [Pr. PC01 Acceleration time constant 1] Deceleration time constant: setting value of [Pr. PC02 Deceleration time constant 1] 2. When RT is turned on Acceleration time constant: setting value of [Pr. PC30 Acceleration time constant 2] Deceleration time constant: setting value of [Pr. PC31 Deceleration time constant 2]
Station home position shift distance (Note 1, 2)	[Pr. PT40]	Set a shift distance of the station home position (station No. 0) for the home position return completion.

- Note
1. The setting of the station home position shift distance is disabled at home position return. Cycling the power will enable the setting.
 2. [Pr. PT40 Station home position shift distance] is enabled as an offset to the position that the home position return is performed. If a larger value than the in-position range is set to [Pr. PT40], the completion output of positioning will not turn on (short circuit) at the first power on after home position return.

6. HOW TO USE INDEXER

(2) Timing chart

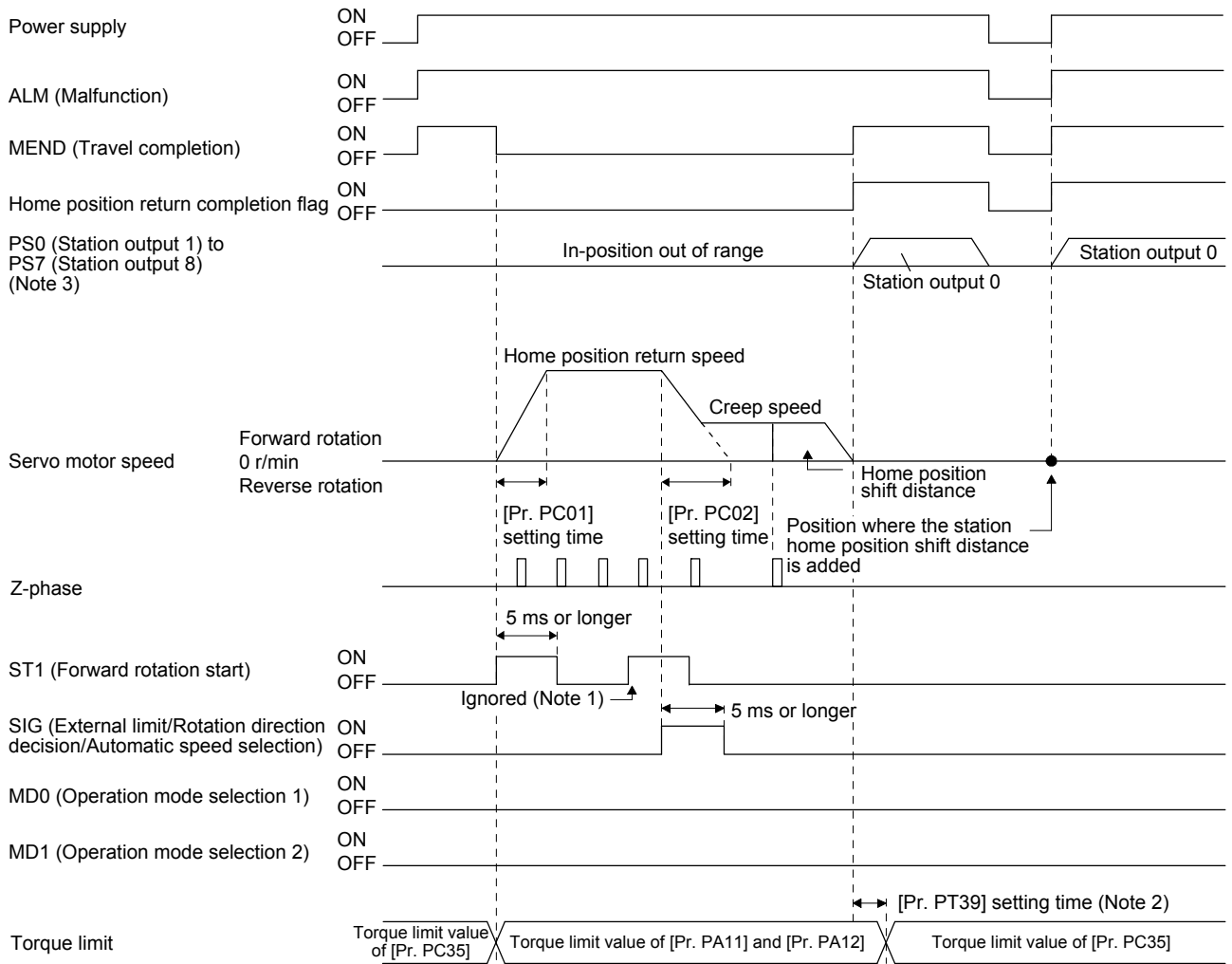

- Note 1. When the rest of command travel distance is other than "0", turning on ST1 (Forward rotation start) will not be enabled.
- Note 2. Counting will start when the rest of command travel distance becomes "0".
- Note 3. For MR-J4-03A6-RJ servo amplifiers, up to six points of DO are available; therefore, PS0 to PS7 cannot be outputted simultaneously.

6. HOW TO USE INDEXER

6.4.3 Torque limit changing data set type

POINT
<ul style="list-style-type: none"> ● When the data set type home position return is selected, [AL. 52] and [AL. 42] will not be detected. ● If the servo motor is rotated in the home position return mode and the mode is changed to automatic mode without home position return, the following may occur. <ol style="list-style-type: none"> 1. [AL. 42] or [AL. 52] can occur. 2. Even though [AL. 42] or [AL. 52] does not occur, the motor will try to compensate a position gap to the command position at start signal input because the current position is out of position with the command position. Watch out for the servo motor rotation due to the compensation the gap to zero between command position and current position. ● When [AL. 90] is occurring, performing home position return will automatically cancel the alarm. ● When [AL. 25] is occurring, cycling the power will cancel the alarm.

When setting any position as home, use the torque limit changing data set type home position return. The JOG operation, manual pulse generator operation, and others can be used for the travel. With this home position return, torque will not be generated simultaneously at switching to the home position return mode. The shaft can be rotated with an external force to set any home position. Additionally, SIG is not used. SIG is disabled even if turn off.

(1) Device/parameter

Set input devices and parameters as follows.

Item	Used device/parameter	Setting
Home position return mode selection	MD0 (Operation mode selection 1)	Switch off MD0.
	MD1 (Operation mode selection 2)	Switch off MD1.
Data set type home position return	[Pr. PT04]	Select " __ _ 2" (Select the torque limit changing data set type.).
Station home position shift distance (Note 1, 2)	[Pr. PT40]	Set a shift distance of the station home position (station No. 0) for the home position return completion.

- Note
1. The setting of the station home position shift distance is disabled at home position return. Cycling the power will enable the setting.
 2. [Pr. PT40 Station home position shift distance] is enabled as an offset to the position that the home position return is performed. If a larger value than the in-position range is set to [Pr. PT40], the completion output of positioning will not turn on (short circuit) at the first power on after home position return.

6. HOW TO USE INDEXER

(2) Timing chart

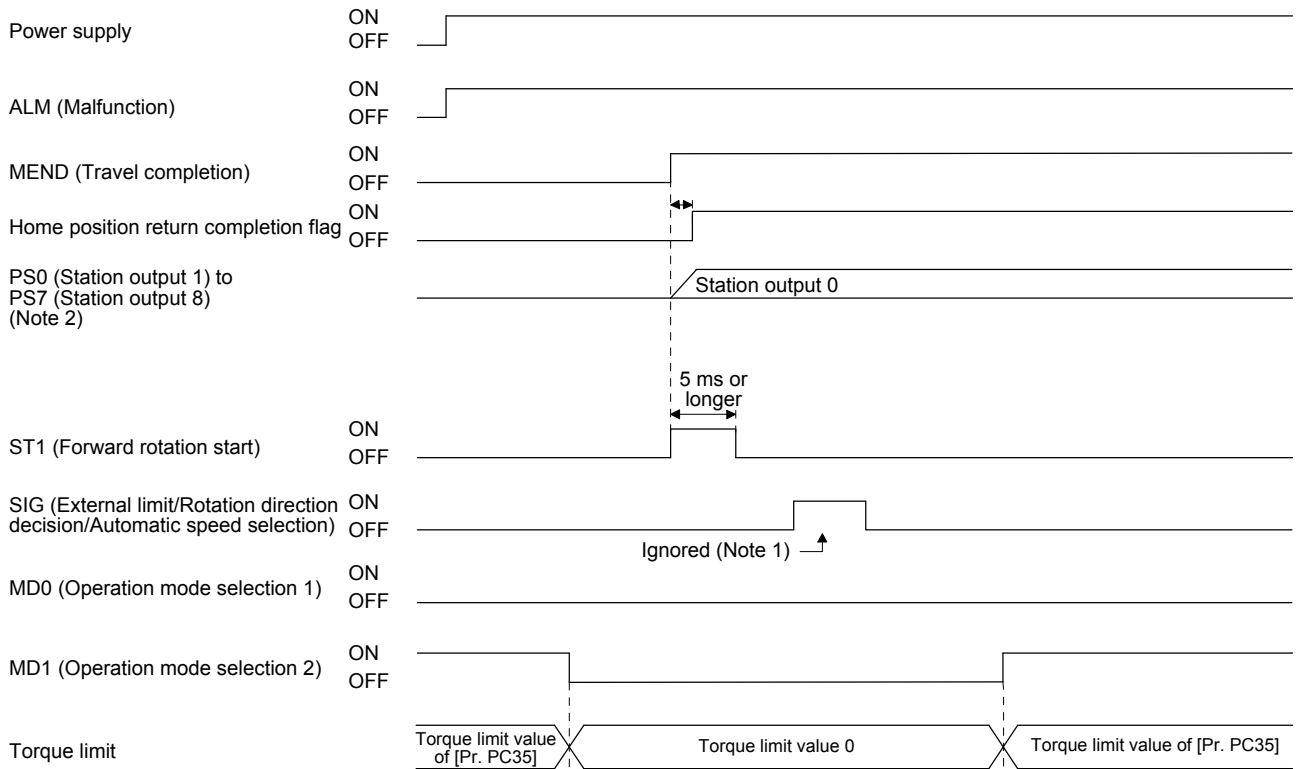

- Note 1. When a data set type home position return is performed, SIG will be disabled.
- Note 2. For MR-J4-03A6-RJ servo amplifiers, up to six points of DO are available; therefore, PS0 to PS7 cannot be outputted simultaneously.

6. HOW TO USE INDEXER

6.4.4 Backlash compensation and digital override

(1) Backlash compensation

When executing a positioning reversely to the direction to the home position return, set [Pr. PT14 Backlash compensation] to stop the shaft at the compensated position for the setting value.

When the travel distance between stations is set to 1000 and the backlash compensation is set to 10 in the absolute position detection system, the timing chart is as follows.

(a) Torque limit changing dog type home position return

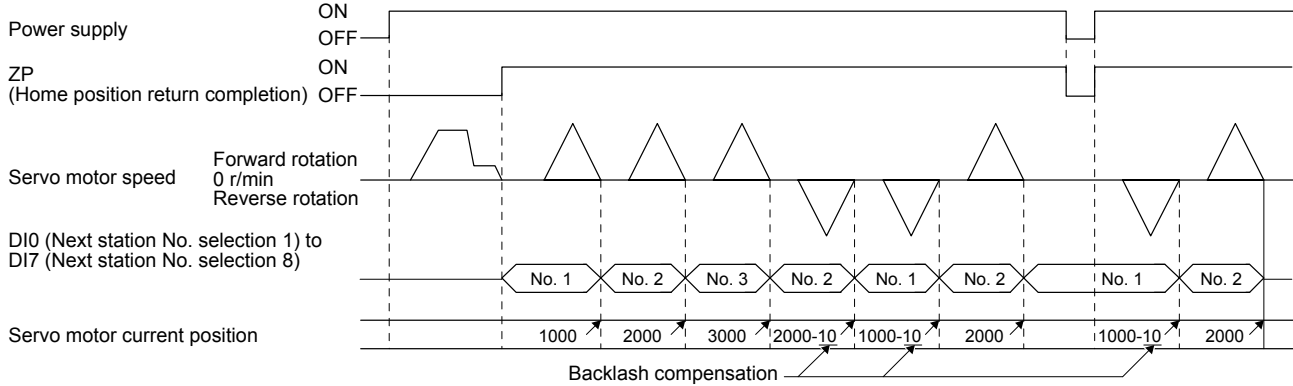

(b) Torque limit changing data set type

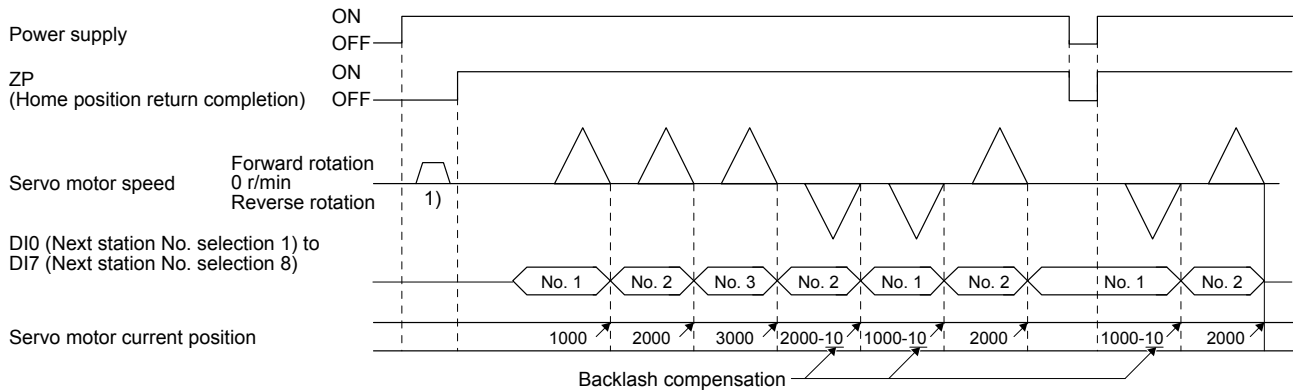

Backlash is compensated to the direction set with [Pr. PT38] regardless of a JOG operation (1)) or disturbance after power-on.

[Pr. PT38] setting	Backlash compensation
"0 _ _ _"	Executes backlash compensation assuming a command to the CW rotation direction before home position return.
"1 _ _ _"	Executes backlash compensation assuming a command to the CCW rotation direction before home position return.

6. HOW TO USE INDEXER

(2) Digital override

Setting [Pr. PT38] to "_ _ 1 _" enables the digital override function.

Actual servo motor speed will be the value multiplying the command speed by the digital override selected with OV0 (Digital override selection 1) to OV3 (Digital override selection 4). This is enabled with all the operation modes.

Example) [Pr. PT42]: 50, [Pr. PT43]: 5

(Note) Device				Description
OV3	OV2	OV1	OV0	
0	0	0	0	100 [%] of parameter setting speed
0	0	0	1	50 [%] of parameter setting speed
0	0	1	0	55 [%] of parameter setting speed
0	0	1	1	60 [%] of parameter setting speed
.
.
.
1	1	0	1	110 [%] of parameter setting speed
1	1	1	0	115 [%] of parameter setting speed
1	1	1	1	0 [%] of parameter setting speed

Note. 0: Off
1: On

(a) When [Pr. PT42] is set to 50 and [Pr. PT43] to 5 in the automatic operation mode 1 (Rotation direction specifying indexer), the chart will be as follows.

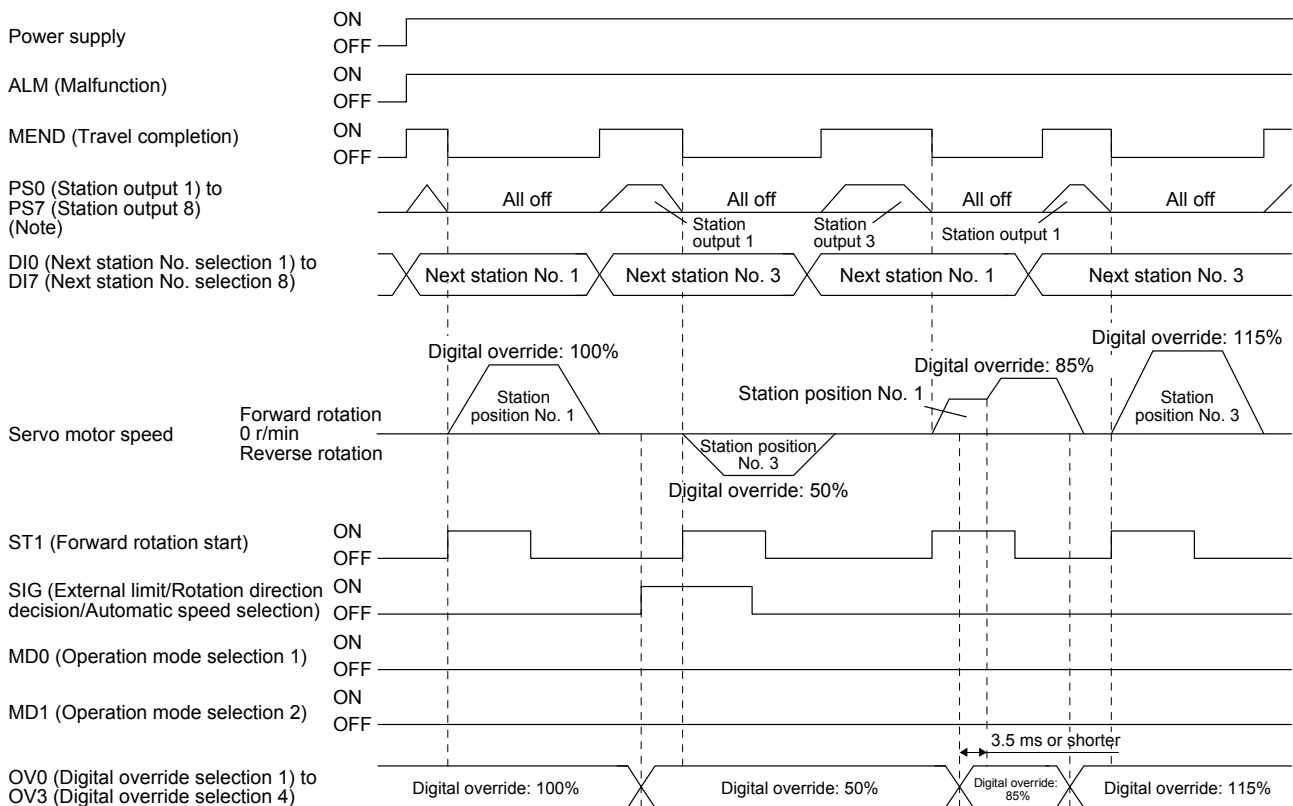

Note. For MR-J4-03A6-RJ servo amplifiers, up to six points of DO are available; therefore, PS0 to PS7 cannot be outputted simultaneously.

6. HOW TO USE INDEXER

POINT
<ul style="list-style-type: none"> ● Speed changes with the digital override function are enabled with the following conditions. <ul style="list-style-type: none"> ▪ Automatic operation mode ▪ Manual operation mode ▪ Home position return is in progress.

(b) When [Pr. PT42] is set to 50 and [Pr. PT43] to 5 in the station JOG operation, the chart will be as follows.

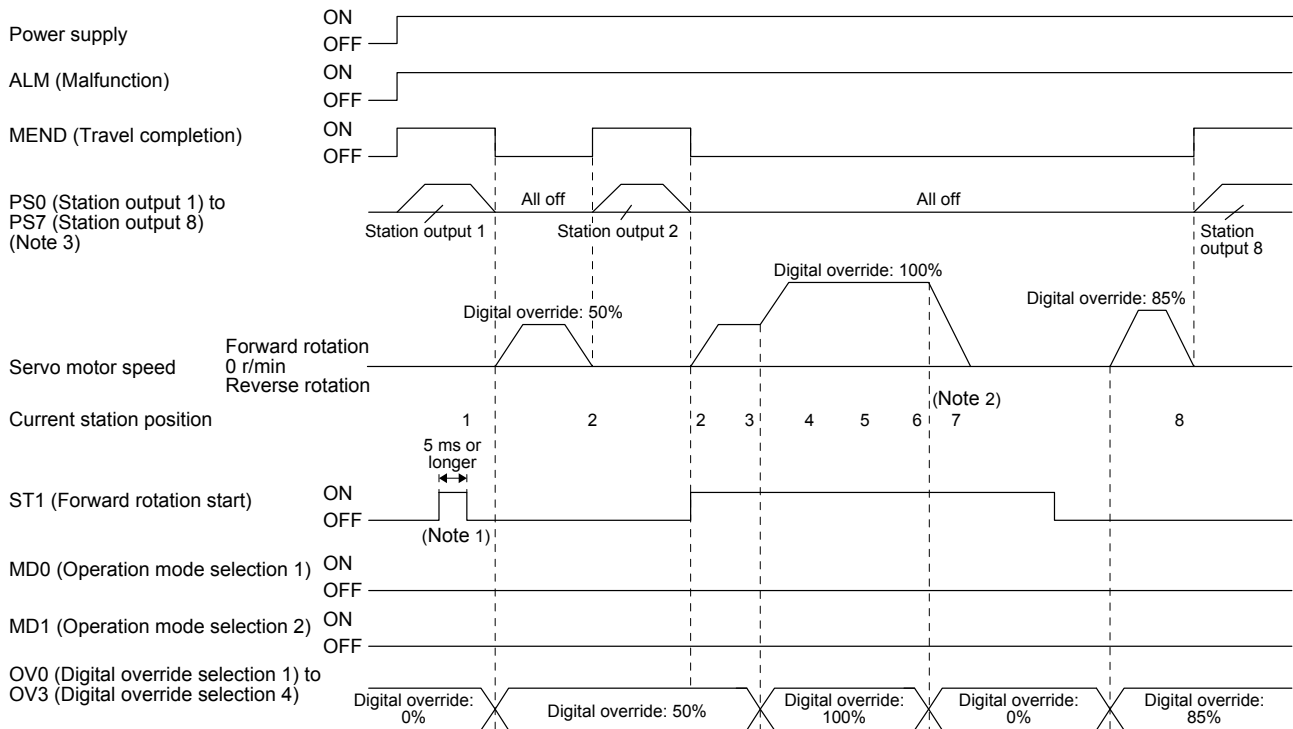

- Note 1. In the manual operation mode, when turning on/off ST1 (Forward rotation start) with 0% digital override and change the digital override to other than 0%, the shaft will stop at the closest station regardless of ST1 (Forward rotation start) off.
- Note 2. Changing the digital override to 0% during operation will decelerate to a stop. Then, the digital override is changed to 0%, JOG operation will start again. In that case, the shaft stops at the closest station regardless of ST1 (Forward rotation start) off.
- Note 3. For MR-J4-03A6-RJ servo amplifiers, up to six points of DO are available; therefore, PS0 to PS7 cannot be outputted simultaneously.

6. HOW TO USE INDEXER

6.4.5 Safety precautions

(1) I/O signal

(a) When a home position return is not executed in the absolute position detection system and incremental system...

The station output signals will not be outputted (all off).

(b) When one or more home position returns is completed...

1) At power-on and forced stop, corresponding station output signal will be outputted if only it is within the in-position range of each next station position.

2) After power-on or during servo motor driving after forced stop, PS0 (Station output 1) to PS7 (Station output 8) will be off without change with a command travel distance other than "0" even if it is within the in-position range of target next station.

3) After power-on or after servo motor driving after forced stop canceled, corresponding station output signal will be outputted if only it is within the in-position range of target next station to stop with the rest of command travel distance "0".

(2) Torque limit

The torque limit will change from the setting value of [Pr. PC35 Internal torque limit 2] to the setting value of [Pr. PA11 Forward rotation torque limit] or [Pr. PA12 Reverse rotation torque limit] at inputting ST1 (Forward rotation start) of the automatic operation mode 1, automatic operation mode 2, manual operation, and torque limit changing dog type home position return. Additionally, after positioning completed signal is outputted, the time has passed set with [Pr. PT39] and the torque limit will change from [Pr. PA11 Forward rotation torque limit] or [Pr. PA12 Reverse rotation torque limit] to the setting value of [Pr. PC35 Internal torque limit 2].

(3) Test operation

Always turn off the power after the JOG test operation, positioning test operation, and machine analyzer function operation. The shaft cannot stop at the next station position because the coordinate system has a gap for the shaft control.

(4) Deceleration to a stop function

When the operation is stopped with the deceleration to a stop function during each operation mode of the rotation direction specifying indexer, shortest rotating indexer, and station JOG, the shaft will stop regardless of the station position.

7. PARAMETERS

7. PARAMETERS



CAUTION

- Never make a drastic adjustment or change to the parameter values as doing so will make the operation unstable.
- Do not change the parameter settings as described below. Doing so may cause an unexpected condition, such as failing to start up the servo amplifier.
 - Changing the values of the parameters for manufacturer setting
 - Setting a value out of the range
 - Changing the fixed values in the digits of a parameter

POINT

- The following parameters are not available with MR-J4-03A6-RJ servo amplifiers.
 - [Pr. PA02 Regenerative option]
 - [Pr. PA17 Servo motor series setting]
 - [Pr. PA18 Servo motor type setting]
 - [Pr. PA26 Function selection A-5]
 - [Pr. PC44 Function selection C-9]
 - [Pr. PC45 Function selection C-A]
 - [Pr. PD47 Output device selection 7]
 - [Pr. PE03 Fully closed loop function selection 2]
 - [Pr. PE04 Fully closed loop control - Feedback pulse electronic gear 1 - Numerator]
 - [Pr. PE05 Fully closed loop control - Feedback pulse electronic gear 1 - Denominator]
 - [Pr. PE06 Fully closed loop control - Speed deviation error detection level]
 - [Pr. PE07 Fully closed loop control - Position deviation error detection level]
 - [Pr. PE08 Fully closed loop dual feedback filter]
 - [Pr. PE10 Fully closed loop function selection 3]
 - [Pr. PE34 Fully closed loop control - Feedback pulse electronic gear 2 - Numerator]
 - [Pr. PE35 Fully closed loop control - Feedback pulse electronic gear 2 - Denominator]
 - [Pr. PF25 SEMI-F47 function - Instantaneous power failure detection time]
 - [Pr. PF34 RS-422 communication function selection 3]
- Linear servo motor/DD motor setting parameters ([Pr. PL_ _]) cannot be used with MR-J4-03A6-RJ servo amplifiers.

7. PARAMETERS

7.1 Parameter list

POINT
<ul style="list-style-type: none">● To enable a parameter whose symbol is preceded by *, cycle the power after setting it.● Abbreviations of operation modes indicate the followings. Standard: Standard (semi closed loop system) use of the rotary servo motor Full.: Fully closed loop system use of the rotary servo motor Lin.: Linear servo motor use DD: Direct drive (DD) motor use● For MR-J4-03A6-RJ servo amplifiers, the operation mode is available only in standard (semi closed loop system).● The symbols in the control mode column mean as follows. CP: Positioning mode (point table method) BCD: Positioning mode (point table method in the BCD input positioning operation) This method is available only when the MR-D01 unit is connected. Refer to chapter 12 for details. CL: Positioning mode (program method) PS: Positioning mode (indexer method)● Setting a value out of the setting range in each parameter will trigger [AL. 37 Parameter error].

7. PARAMETERS

7.1.1 Basic setting parameters ([Pr. PA_ _])

POINT
<ul style="list-style-type: none"> ● To enable the following parameters in a positioning mode, cycle the power after setting. <ul style="list-style-type: none"> ▪ [Pr. PA06 Electronic gear numerator (command pulse multiplication numerator)/Number of gear teeth on machine side] ▪ [Pr. PA06 Electronic gear denominator (command pulse multiplication denominator)/Number of gear teeth on servo motor side] ● The following parameter cannot be used in the positioning mode. <ul style="list-style-type: none"> ▪ [Pr. PA05 Number of command input pulses per revolution]

No.	Symbol	Name	Initial value	Unit	Operation mode				Control mode		
					Standard	Full.	Lin.	DD	CP/BCD	CL	σ _α
PA01	*STY	Operation mode	1000h		○	○	○	○	○	○	○
PA02	*REG	Regenerative option	0000h		○	○	○	○	○	○	○
PA03	*ABS	Absolute position detection system	0000h		○	○	○	○	○	○	○
PA04	*AOP1	Function selection A-1	2000h		○	○	○	○	○	○	○
PA05	*FBP	Number of command input pulses per revolution	10000		○	○	○	○	○	○	○
PA06	*CMX	Electronic gear numerator (command pulse multiplication numerator)	1		○	○	○	○	○	○	○
		Number of gear teeth on machine side	1		○	○	○	○	○	○	○
PA07	*CDV	Electronic gear denominator (command pulse multiplication denominator)	1		○	○	○	○	○	○	○
		Number of gear teeth on servo motor side	1		○	○	○	○	○	○	○
PA08	ATU	Auto tuning mode	0001h		○	○	○	○	○	○	○
PA09	RSP	Auto tuning response	16		○	○	○	○	○	○	○
PA10	INP	In-position range	100	[μm]/ 10 ⁻⁴ [inch]/ 10 ⁻³ [degree]/ [pulse]	○	○	○	○	○	○	○
PA11	TLP	Forward rotation torque limit/positive direction thrust limit	100.0	[%]	○	○	○	○	○	○	○
PA12	TLN	Reverse rotation torque limit/negative direction thrust limit	100.0	[%]	○	○	○	○	○	○	○
PA13	*PLSS	Command pulse input form	0100h		○	○	○	○	○	○	○
PA14	*POL	Rotation direction selection/travel direction selection	0		○	○	○	○	○	○	○
PA15	*ENR	Encoder output pulses	4000	[pulse/rev]	○	○	○	○	○	○	○
PA16	*ENR2	Encoder output pulses 2	1		○	○	○	○	○	○	○
PA17	*MSR	Servo motor series setting	0000h		○	○	○	○	○	○	○
PA18	*MTY	Servo motor type setting	0000h		○	○	○	○	○	○	○
PA19	*BLK	Parameter writing inhibit	00AAh		○	○	○	○	○	○	○
PA20	*TDS	Tough drive setting	0000h		○	○	○	○	○	○	○
PA21	*AOP3	Function selection A-3	0001h		○	○	○	○	○	○	○
PA22	*PCS	Position control composition selection	0000h		○	○	○	○	○	○	○
PA23	DRAT	Drive recorder arbitrary alarm trigger setting	0000h		○	○	○	○	○	○	○
PA24	AOP4	Function selection A-4	0000h		○	○	○	○	○	○	○
PA25	OTHOV	One-touch tuning - Overshoot permissible level	0	[%]	○	○	○	○	○	○	○
PA26	*AOP5	Function selection A-5	0000h		○	○	○	○	○	○	○
PA27		For manufacturer setting	0000h		○	○	○	○	○	○	○
PA28			0000h		○	○	○	○	○	○	○
PA29			0000h		○	○	○	○	○	○	○
PA30			0000h		○	○	○	○	○	○	○
PA31			0000h		○	○	○	○	○	○	○
PA32			0000h		○	○	○	○	○	○	○

7. PARAMETERS

7.1.2 Gain/filter setting parameters ([Pr. PB_ _])

No.	Symbol	Name	Initial value	Unit	Operation mode				Control mode		
					Standard	Full.	Lin.	DD	CP/BCD	CL	PS
PB01	FILT	Adaptive tuning mode (adaptive filter II)	0000h		<input type="radio"/>	<input type="radio"/>	<input type="radio"/>	<input type="radio"/>	<input type="radio"/>	<input type="radio"/>	<input type="radio"/>
PB02	VRFT	Vibration suppression control tuning mode (advanced vibration suppression control II)	0000h		<input type="radio"/>	<input type="radio"/>	<input type="radio"/>	<input type="radio"/>	<input type="radio"/>	<input type="radio"/>	<input type="radio"/>
PB03	PST	Position command acceleration/deceleration time constant (position smoothing)	0	[ms]	<input type="radio"/>	<input type="radio"/>	<input type="radio"/>	<input type="radio"/>	<input type="radio"/>	<input type="radio"/>	<input type="radio"/>
PB04	FFC	Feed forward gain	0	[%]	<input type="radio"/>	<input type="radio"/>	<input type="radio"/>	<input type="radio"/>	<input type="radio"/>	<input type="radio"/>	<input type="radio"/>
PB05		For manufacturer setting	500		<input type="radio"/>	<input type="radio"/>	<input type="radio"/>	<input type="radio"/>	<input type="radio"/>	<input type="radio"/>	<input type="radio"/>
PB06	GD2	Load to motor inertia ratio/load to motor mass ratio	7.00	[Multiplier]	<input type="radio"/>	<input type="radio"/>	<input type="radio"/>	<input type="radio"/>	<input type="radio"/>	<input type="radio"/>	<input type="radio"/>
PB07	PG1	Model loop gain	15.0	[rad/s]	<input type="radio"/>	<input type="radio"/>	<input type="radio"/>	<input type="radio"/>	<input type="radio"/>	<input type="radio"/>	<input type="radio"/>
PB08	PG2	Position loop gain	37.0	[rad/s]	<input type="radio"/>	<input type="radio"/>	<input type="radio"/>	<input type="radio"/>	<input type="radio"/>	<input type="radio"/>	<input type="radio"/>
PB09	VG2	Speed loop gain	823	[rad/s]	<input type="radio"/>	<input type="radio"/>	<input type="radio"/>	<input type="radio"/>	<input type="radio"/>	<input type="radio"/>	<input type="radio"/>
PB10	VIC	Speed integral compensation	33.7	[ms]	<input type="radio"/>	<input type="radio"/>	<input type="radio"/>	<input type="radio"/>	<input type="radio"/>	<input type="radio"/>	<input type="radio"/>
PB11	VDC	Speed differential compensation	980		<input type="radio"/>	<input type="radio"/>	<input type="radio"/>	<input type="radio"/>	<input type="radio"/>	<input type="radio"/>	<input type="radio"/>
PB12	OVA	Overshoot amount compensation	0	[%]	<input type="radio"/>	<input type="radio"/>	<input type="radio"/>	<input type="radio"/>	<input type="radio"/>	<input type="radio"/>	<input type="radio"/>
PB13	NH1	Machine resonance suppression filter 1	4500	[Hz]	<input type="radio"/>	<input type="radio"/>	<input type="radio"/>	<input type="radio"/>	<input type="radio"/>	<input type="radio"/>	<input type="radio"/>
PB14	NHQ1	Notch shape selection 1	0000h		<input type="radio"/>	<input type="radio"/>	<input type="radio"/>	<input type="radio"/>	<input type="radio"/>	<input type="radio"/>	<input type="radio"/>
PB15	NH2	Machine resonance suppression filter 2	4500	[Hz]	<input type="radio"/>	<input type="radio"/>	<input type="radio"/>	<input type="radio"/>	<input type="radio"/>	<input type="radio"/>	<input type="radio"/>
PB16	NHQ2	Notch shape selection 2	0000h		<input type="radio"/>	<input type="radio"/>	<input type="radio"/>	<input type="radio"/>	<input type="radio"/>	<input type="radio"/>	<input type="radio"/>
PB17	NHF	Shaft resonance suppression filter	0000h		<input type="radio"/>	<input type="radio"/>	<input type="radio"/>	<input type="radio"/>	<input type="radio"/>	<input type="radio"/>	<input type="radio"/>
PB18	LPF	Low-pass filter setting	3141	[rad/s]	<input type="radio"/>	<input type="radio"/>	<input type="radio"/>	<input type="radio"/>	<input type="radio"/>	<input type="radio"/>	<input type="radio"/>
PB19	VRF11	Vibration suppression control 1 - Vibration frequency	100.0	[Hz]	<input type="radio"/>	<input type="radio"/>	<input type="radio"/>	<input type="radio"/>	<input type="radio"/>	<input type="radio"/>	<input type="radio"/>
PB20	VRF12	Vibration suppression control 1 - Resonance frequency	100.0	[Hz]	<input type="radio"/>	<input type="radio"/>	<input type="radio"/>	<input type="radio"/>	<input type="radio"/>	<input type="radio"/>	<input type="radio"/>
PB21	VRF13	Vibration suppression control 1 - Vibration frequency damping	0.00		<input type="radio"/>	<input type="radio"/>	<input type="radio"/>	<input type="radio"/>	<input type="radio"/>	<input type="radio"/>	<input type="radio"/>
PB22	VRF14	Vibration suppression control 1 - Resonance frequency damping	0.00		<input type="radio"/>	<input type="radio"/>	<input type="radio"/>	<input type="radio"/>	<input type="radio"/>	<input type="radio"/>	<input type="radio"/>
PB23	VFBF	Low-pass filter selection	0000h		<input type="radio"/>	<input type="radio"/>	<input type="radio"/>	<input type="radio"/>	<input type="radio"/>	<input type="radio"/>	<input type="radio"/>
PB24	*MVS	Slight vibration suppression control	0000h		<input type="radio"/>	<input type="radio"/>	<input type="radio"/>	<input type="radio"/>	<input type="radio"/>	<input type="radio"/>	<input type="radio"/>
PB25	*BOP1	Function selection B-1	0000h		<input type="radio"/>	<input type="radio"/>	<input type="radio"/>	<input type="radio"/>	<input type="radio"/>	<input type="radio"/>	<input type="radio"/>
PB26	*CDP	Gain switching function	0000h		<input type="radio"/>	<input type="radio"/>	<input type="radio"/>	<input type="radio"/>	<input type="radio"/>	<input type="radio"/>	<input type="radio"/>
PB27	CDL	Gain switching condition	10	[kpulse/s]/ [pulse]/ [r/min]	<input type="radio"/>	<input type="radio"/>	<input type="radio"/>	<input type="radio"/>	<input type="radio"/>	<input type="radio"/>	<input type="radio"/>
PB28	CDT	Gain switching time constant	1	[ms]	<input type="radio"/>	<input type="radio"/>	<input type="radio"/>	<input type="radio"/>	<input type="radio"/>	<input type="radio"/>	<input type="radio"/>
PB29	GD2B	Load to motor inertia ratio/load to motor mass ratio after gain switching	7.00	[Multiplier]	<input type="radio"/>	<input type="radio"/>	<input type="radio"/>	<input type="radio"/>	<input type="radio"/>	<input type="radio"/>	<input type="radio"/>
PB30	PG2B	Position loop gain after gain switching	0.0	[rad/s]	<input type="radio"/>	<input type="radio"/>	<input type="radio"/>	<input type="radio"/>	<input type="radio"/>	<input type="radio"/>	<input type="radio"/>
PB31	VG2B	Speed loop gain after gain switching	0	[rad/s]	<input type="radio"/>	<input type="radio"/>	<input type="radio"/>	<input type="radio"/>	<input type="radio"/>	<input type="radio"/>	<input type="radio"/>
PB32	VICB	Speed integral compensation after gain switching	0.0	[ms]	<input type="radio"/>	<input type="radio"/>	<input type="radio"/>	<input type="radio"/>	<input type="radio"/>	<input type="radio"/>	<input type="radio"/>
PB33	VRF1B	Vibration suppression control 1 - Vibration frequency after gain switching	0.0	[Hz]	<input type="radio"/>	<input type="radio"/>	<input type="radio"/>	<input type="radio"/>	<input type="radio"/>	<input type="radio"/>	<input type="radio"/>
PB34	VRF2B	Vibration suppression control 1 - Resonance frequency after gain switching	0.0	[Hz]	<input type="radio"/>	<input type="radio"/>	<input type="radio"/>	<input type="radio"/>	<input type="radio"/>	<input type="radio"/>	<input type="radio"/>
PB35	VRF3B	Vibration suppression control 1 - Vibration frequency damping after gain switching	0.00		<input type="radio"/>	<input type="radio"/>	<input type="radio"/>	<input type="radio"/>	<input type="radio"/>	<input type="radio"/>	<input type="radio"/>
PB36	VRF4B	Vibration suppression control 1 - Resonance frequency damping after gain switching	0.00		<input type="radio"/>	<input type="radio"/>	<input type="radio"/>	<input type="radio"/>	<input type="radio"/>	<input type="radio"/>	<input type="radio"/>

7. PARAMETERS

No.	Symbol	Name	Initial value	Unit	Operation mode				Control mode		
					Standard	Full.	Lin.	DD	CP/BCD	CL	PS
PB37		For manufacturer setting	1600								
PB38			0.00								
PB39			0.00								
PB40			0.00								
PB41			0000h								
PB42			0000h								
PB43			0000h								
PB44			0.00								
PB45	CNHF	Command notch filter	0000h			<input type="radio"/>	<input type="radio"/>	<input type="radio"/>	<input type="radio"/>	<input type="radio"/>	<input type="radio"/>
PB46	NH3	Machine resonance suppression filter 3	4500	[Hz]		<input type="radio"/>	<input type="radio"/>	<input type="radio"/>	<input type="radio"/>	<input type="radio"/>	<input type="radio"/>
PB47	NHQ3	Notch shape selection 3	0000h			<input type="radio"/>	<input type="radio"/>	<input type="radio"/>	<input type="radio"/>	<input type="radio"/>	<input type="radio"/>
PB48	NH4	Machine resonance suppression filter 4	4500	[Hz]		<input type="radio"/>	<input type="radio"/>	<input type="radio"/>	<input type="radio"/>	<input type="radio"/>	<input type="radio"/>
PB49	NHQ4	Notch shape selection 4	0000h			<input type="radio"/>	<input type="radio"/>	<input type="radio"/>	<input type="radio"/>	<input type="radio"/>	<input type="radio"/>
PB50	NH5	Machine resonance suppression filter 5	4500	[Hz]		<input type="radio"/>	<input type="radio"/>	<input type="radio"/>	<input type="radio"/>	<input type="radio"/>	<input type="radio"/>
PB51	NHQ5	Notch shape selection 5	0000h			<input type="radio"/>	<input type="radio"/>	<input type="radio"/>	<input type="radio"/>	<input type="radio"/>	<input type="radio"/>
PB52	VRF21	Vibration suppression control 2 - Vibration frequency	100.0	[Hz]		<input type="radio"/>	<input type="radio"/>	<input type="radio"/>	<input type="radio"/>	<input type="radio"/>	<input type="radio"/>
PB53	VRF22	Vibration suppression control 2 - Resonance frequency	100.0	[Hz]		<input type="radio"/>	<input type="radio"/>	<input type="radio"/>	<input type="radio"/>	<input type="radio"/>	<input type="radio"/>
PB54	VRF23	Vibration suppression control 2 - Vibration frequency damping	0.00			<input type="radio"/>	<input type="radio"/>	<input type="radio"/>	<input type="radio"/>	<input type="radio"/>	<input type="radio"/>
PB55	VRF24	Vibration suppression control 2 - Resonance frequency damping	0.00			<input type="radio"/>	<input type="radio"/>	<input type="radio"/>	<input type="radio"/>	<input type="radio"/>	<input type="radio"/>
PB56	VRF21B	Vibration suppression control 2 - Vibration frequency after gain switching	0.0	[Hz]		<input type="radio"/>	<input type="radio"/>	<input type="radio"/>	<input type="radio"/>	<input type="radio"/>	<input type="radio"/>
PB57	VRF22B	Vibration suppression control 2 - Resonance frequency after gain switching	0.0	[Hz]		<input type="radio"/>	<input type="radio"/>	<input type="radio"/>	<input type="radio"/>	<input type="radio"/>	<input type="radio"/>
PB58	VRF23B	Vibration suppression control 2 - Vibration frequency damping after gain switching	0.00			<input type="radio"/>	<input type="radio"/>	<input type="radio"/>	<input type="radio"/>	<input type="radio"/>	<input type="radio"/>
PB59	VRF24B	Vibration suppression control 2 - Resonance frequency damping after gain switching	0.00			<input type="radio"/>	<input type="radio"/>	<input type="radio"/>	<input type="radio"/>	<input type="radio"/>	<input type="radio"/>
PB60	PG1B	Model loop gain after gain switching	0.0	[rad/s]		<input type="radio"/>	<input type="radio"/>	<input type="radio"/>	<input type="radio"/>	<input type="radio"/>	<input type="radio"/>
PB61		For manufacturer setting	0.0								
PB62			0000h								
PB63			0000h								
PB64			0000h								

7. PARAMETERS

7.1.3 Extension setting parameters ([Pr. PC__])

POINT
<ul style="list-style-type: none"> ● To enable the following parameters in a positioning mode, cycle the power after setting. <ul style="list-style-type: none"> ▪ [Pr. PC03 S-pattern acceleration/deceleration time constant] ● The following parameter cannot be used in the positioning mode. <ul style="list-style-type: none"> ▪ [Pr. PC04 Torque command time constant/thrust command time constant] ▪ [Pr. PC08 Internal speed command 4/internal speed limit 4] ▪ [Pr. PC09 Internal speed command 5/internal speed limit 5] ▪ [Pr. PC10 Internal speed command 6/internal speed limit 6] ▪ [Pr. PC11 Internal speed command 7/internal speed limit 7] ▪ [Pr. PC12 Analog speed command - Maximum speed/Analog speed limit - Maximum speed] ▪ [Pr. PC13 Analog torque/thrust command maximum output] ▪ [Pr. PC23 Function selection C-2] ▪ [Pr. PC32 Command input pulse multiplication numerator 2] ▪ [Pr. PC33 Command input pulse multiplication numerator 3] ▪ [Pr. PC34 Command input pulse multiplication numerator 4] ● The following parameters are used for Modbus-RTU communication. For details, refer to "MR-J4-_A_-RJ Servo Amplifier Instruction Manual (Modbus-RTU communication)". <ul style="list-style-type: none"> ▪ [Pr. PC70 Modbus-RTU communication station number setting] ▪ [Pr. PC71 Function selection C-F] ▪ [Pr. PC72 Function selection C-G]

No.	Symbol	Name	Initial value	Unit	Operation mode				Control mode	
					Standard	Full.	Lin.	DD	CP/BCD	CL
PC01	STA	JOG operation acceleration time constant	0	[ms]	<input type="radio"/>	<input type="radio"/>	<input type="radio"/>	<input type="radio"/>	<input type="radio"/>	<input type="radio"/>
		Acceleration time constant 1			<input type="radio"/>	<input type="radio"/>	<input type="radio"/>	<input type="radio"/>	<input type="radio"/>	<input type="radio"/>
PC02	STB	JOG operation deceleration time constant	0	[ms]	<input type="radio"/>	<input type="radio"/>	<input type="radio"/>	<input type="radio"/>	<input type="radio"/>	<input type="radio"/>
		Deceleration time constant 1			<input type="radio"/>	<input type="radio"/>	<input type="radio"/>	<input type="radio"/>	<input type="radio"/>	<input type="radio"/>
PC03	*STC	S-pattern acceleration/deceleration time constant	0	[ms]	<input type="radio"/>	<input type="radio"/>	<input type="radio"/>	<input type="radio"/>	<input type="radio"/>	<input type="radio"/>
PC04	TQC	Torque command time constant/thrust command time constant	0		<input type="radio"/>	<input type="radio"/>	<input type="radio"/>	<input type="radio"/>	<input type="radio"/>	<input type="radio"/>
PC05	SC1	Automatic operation speed 1	100	[r/min]	<input type="radio"/>	<input type="radio"/>	<input type="radio"/>	<input type="radio"/>	<input type="radio"/>	<input type="radio"/>
PC06	SC2	Automatic operation speed 2	500	[r/min]	<input type="radio"/>	<input type="radio"/>	<input type="radio"/>	<input type="radio"/>	<input type="radio"/>	<input type="radio"/>
PC07	SC3	Manual operation speed 1	1000	[r/min]	<input type="radio"/>	<input type="radio"/>	<input type="radio"/>	<input type="radio"/>	<input type="radio"/>	<input type="radio"/>
PC08	SC4	Internal speed command 4	200	[r/min]/ [mm/s]	<input type="radio"/>	<input type="radio"/>	<input type="radio"/>	<input type="radio"/>	<input type="radio"/>	<input type="radio"/>
		Internal speed limit 4			<input type="radio"/>	<input type="radio"/>	<input type="radio"/>	<input type="radio"/>	<input type="radio"/>	<input type="radio"/>
PC09	SC5	Internal speed command 5	300	[r/min]/ [mm/s]	<input type="radio"/>	<input type="radio"/>	<input type="radio"/>	<input type="radio"/>	<input type="radio"/>	<input type="radio"/>
		Internal speed limit 5			<input type="radio"/>	<input type="radio"/>	<input type="radio"/>	<input type="radio"/>	<input type="radio"/>	<input type="radio"/>
PC10	SC6	Internal speed command 6	500	[r/min]/ [mm/s]	<input type="radio"/>	<input type="radio"/>	<input type="radio"/>	<input type="radio"/>	<input type="radio"/>	<input type="radio"/>
		Internal speed limit 6			<input type="radio"/>	<input type="radio"/>	<input type="radio"/>	<input type="radio"/>	<input type="radio"/>	<input type="radio"/>
PC11	SC7	Internal speed command 7	800	[r/min]/ [mm/s]	<input type="radio"/>	<input type="radio"/>	<input type="radio"/>	<input type="radio"/>	<input type="radio"/>	<input type="radio"/>
		Internal speed limit 7			<input type="radio"/>	<input type="radio"/>	<input type="radio"/>	<input type="radio"/>	<input type="radio"/>	<input type="radio"/>
PC12	VCM	Analog speed command - Maximum speed	0	[r/min]/ [mm/s]	<input type="radio"/>	<input type="radio"/>	<input type="radio"/>	<input type="radio"/>	<input type="radio"/>	<input type="radio"/>
		Analog speed limit - Maximum speed			<input type="radio"/>	<input type="radio"/>	<input type="radio"/>	<input type="radio"/>	<input type="radio"/>	<input type="radio"/>
PC13	TLC	Analog torque/thrust command maximum output	100.0	[%]	<input type="radio"/>	<input type="radio"/>	<input type="radio"/>	<input type="radio"/>	<input type="radio"/>	<input type="radio"/>

7. PARAMETERS

No.	Symbol	Name	Initial value	Unit	Operation mode				Control mode		
					Standard	Full.	Lin.	DD	CP/BCD	CL	PS
PC14	MOD1	Analog monitor 1 output	0000h		○	○	○	○	○	○	○
PC15	MOD2	Analog monitor 2 output	0001h		○	○	○	○	○	○	○
PC16	MBR	Electromagnetic brake sequence output	0	[ms]	○	○	○	○	○	○	○
PC17	ZSP	Zero speed	50	[r/min]/ [mm/s]	○	○	○	○	○	○	○
PC18	*BPS	Alarm history clear	0000h		○	○	○	○	○	○	○
PC19	*ENRS	Encoder output pulse selection	0000h		○	○	○	○	○	○	○
PC20	*SNO	Station No. setting	0	[station]	○	○	○	○	○	○	○
PC21	*SOP	RS-422 communication function selection	0000h		○	○	○	○	○	○	○
PC22	*COP1	Function selection C-1	0000h		○	○	○	○	○	○	○
PC23	*COP2	Function selection C-2	0000h		○	○	○	○	○	○	○
PC24	*COP3	Function selection C-3	0000h		○	○	○	○	○	○	○
PC25		For manufacturer setting	0000h		○	○	○	○	○	○	○
PC26	*COP5	Function selection C-5	0000h		○	○	○	○	○	○	○
PC27	*COP6	Function selection C-6	0000h		○	○	○	○	○	○	○
PC28	*COP7	Function selection C-7	0000h		○	○	○	○	○	○	○
PC29		For manufacturer setting	0000h		○	○	○	○	○	○	○
PC30	STA2	Home position return acceleration time constant	0	[ms]	○	○	○	○	○	○	○
		Acceleration time constant 2			○	○	○	○	○	○	○
PC31	STB2	Home position return deceleration time constant	0	[ms]	○	○	○	○	○	○	○
		Deceleration time constant 2			○	○	○	○	○	○	○
PC32	CMX2	Command input pulse multiplication numerator 2	1		○	○	○	○	○	○	○
PC33	CMX3	Command input pulse multiplication numerator 3	1		○	○	○	○	○	○	○
PC34	CMX4	Command input pulse multiplication numerator 4	1		○	○	○	○	○	○	○
PC35	TL2	Internal torque limit 2/internal thrust limit 2	100.0	[%]	○	○	○	○	○	○	○
PC36	*DMD	Status display selection	0000h		○	○	○	○	○	○	○
PC37	VCO	Analog override offset	0	[mV]	○	○	○	○	○	○	○
PC38	TPO	Analog torque limit offset	0	[mV]	○	○	○	○	○	○	○
PC39	MO1	Analog monitor 1 offset	0	[mV]	○	○	○	○	○	○	○
PC40	MO2	Analog monitor 2 offset	0	[mV]	○	○	○	○	○	○	○
PC41		For manufacturer setting	0		○	○	○	○	○	○	○
PC42			0		○	○	○	○	○	○	○
PC43	ERZ	Error excessive alarm detection level	0	[rev]/[mm]	○	○	○	○	○	○	○
PC44	*COP9	Function selection C-9	0000h		○	○	○	○	○	○	○
PC45	*COPA	Function selection C-A	0000h		○	○	○	○	○	○	○
PC46		For manufacturer setting	0		○	○	○	○	○	○	○
PC47			0		○	○	○	○	○	○	○
PC48			0		○	○	○	○	○	○	○
PC49			0		○	○	○	○	○	○	○
PC50			0000h		○	○	○	○	○	○	○
PC51	RSBR	Forced stop deceleration time constant	100	[ms]	○	○	○	○	○	○	○
PC52		For manufacturer setting	0		○	○	○	○	○	○	○
PC53			0		○	○	○	○	○	○	○
PC54	RSUP1	Vertical axis freefall prevention compensation amount	0	[0.0001rev]/ [0.01mm]	○	○	○	○	○	○	○
PC55		For manufacturer setting	0		○	○	○	○	○	○	○
PC56			100		○	○	○	○	○	○	○
PC57			0000h		○	○	○	○	○	○	○
PC58			0		○	○	○	○	○	○	○
PC59			0000h		○	○	○	○	○	○	○
PC60	*COPD	Function selection C-D	0000h		○	○	○	○	○	○	○

7. PARAMETERS

No.	Symbol	Name	Initial value	Unit	Operation mode				Control mode			
					Standard	Full.	Lin.	DD	CP/BCD	CL	PS	
PC61		For manufacturer setting	0000h									
PC62			0000h									
PC63			0000h									
PC64			0000h									
PC65			0000h									
PC66	LPSPL	Mark detection range + (lower three digits)	0	10 ^{STM} [μm]/ 10 ^(STM-4) [inch]/ 10 ⁻³ [degree]/ [pulse]	○	○	○	○	○	○	○	○
PC67	LPSPH	Mark detection range + (upper three digits)	0	10 ^{STM} [μm]/ 10 ^(STM-4) [inch]/ 10 ⁻³ [degree]/ [pulse]	○	○	○	○	○	○	○	○
PC68	LPSNL	Mark detection range - (lower three digits)	0	10 ^{STM} [μm]/ 10 ^(STM-4) [inch]/ 10 ⁻³ [degree]/ [pulse]	○	○	○	○	○	○	○	○
PC69	LPSNH	Mark detection range - (upper three digits)	0	10 ^{STM} [μm]/ 10 ^(STM-4) [inch]/ 10 ⁻³ [degree]/ [pulse]	○	○	○	○	○	○	○	○
PC70	*SNOM	Modbus-RTU communication station number setting	0		○	○	○	○	○	○	○	○
PC71	*COPF	Function selection C-F	0040h		○	○	○	○	○	○	○	○
PC72	*COPG	Function selection C-G	0000h		○	○	○	○	○	○	○	○
PC73	ERW	Error excessive warning level	0		○	○	○	○	○	○	○	○
PC74		For manufacturer setting	0000h									
PC75			0000h									
PC76			0000h									
PC77			0000h									
PC78			0000h									
PC79			0000h									
PC80			0000h									

7. PARAMETERS

7.1.4 I/O setting parameters ([Pr. PD_ _])

POINT
<p>● The following parameter cannot be used in the positioning mode.</p> <ul style="list-style-type: none"> ▪ [Pr. PD03 Input device selection 1L] ▪ [Pr. PD05 Input device selection 2L] ▪ [Pr. PD07 Input device selection 3L] ▪ [Pr. PD09 Input device selection 4L] ▪ [Pr. PD11 Input device selection 5L] ▪ [Pr. PD13 Input device selection 6L] ▪ [Pr. PD17 Input device selection 8L] ▪ [Pr. PD19 Input device selection 9L] ▪ [Pr. PD21 Input device selection 10L] ▪ [Pr. PD43 Input device selection 11L] ▪ [Pr. PD45 Input device selection 12L]

No.	Symbol	Name	Initial value	Unit	Operation mode				Control mode		
					Standard	Full.	Lin.	DD	CP/BCD	CL	S.P.
PD01	*DIA1	Input signal automatic on selection 1	0000h		○	○	○	○	○	○	○
PD02		For manufacturer setting	0000h		○	○	○	○	○	○	○
PD03	*DI1L	Input device selection 1L	0202h		○	○	○	○	○	○	○
PD04	*DI1H	Input device selection 1H	0202h		○	○	○	○	○	○	○
PD05	*DI2L	Input device selection 2L	2100h		○	○	○	○	○	○	○
PD06	*DI2H	Input device selection 2H	2021h		○	○	○	○	○	○	○
PD07	*DI3L	Input device selection 3L	0704h		○	○	○	○	○	○	○
PD08	*DI3H	Input device selection 3H	0707h		○	○	○	○	○	○	○
PD09	*DI4L	Input device selection 4L	0805h		○	○	○	○	○	○	○
PD10	*DI4H	Input device selection 4H	0808h		○	○	○	○	○	○	○
PD11	*DI5L	Input device selection 5L	0303h		○	○	○	○	○	○	○
PD12	*DI5H	Input device selection 5H	3803h		○	○	○	○	○	○	○
PD13	*DI6L	Input device selection 6L	2006h		○	○	○	○	○	○	○
PD14	*DI6H	Input device selection 6H	3920h		○	○	○	○	○	○	○
PD15		For manufacturer setting	0000h		○	○	○	○	○	○	○
PD16			0000h		○	○	○	○	○	○	○
PD17	*DI8L	Input device selection 8L	0A0Ah		○	○	○	○	○	○	○
PD18	*DI8H	Input device selection 8H	0A00h		○	○	○	○	○	○	○
PD19	*DI9L	Input device selection 9L	0B0Bh		○	○	○	○	○	○	○
PD20	*DI9H	Input device selection 9H	0B00h		○	○	○	○	○	○	○
PD21	*DI10L	Input device selection 10L	2323h		○	○	○	○	○	○	○
PD22	*DI10H	Input device selection 10H	2B23h		○	○	○	○	○	○	○
PD23	*DO1	Output device selection 1	0004h		○	○	○	○	○	○	○
PD24	*DO2	Output device selection 2	000Ch		○	○	○	○	○	○	○
PD25	*DO3	Output device selection 3	0004h		○	○	○	○	○	○	○
PD26	*DO4	Output device selection 4	0007h		○	○	○	○	○	○	○
PD27		For manufacturer setting	0003h		○	○	○	○	○	○	○
PD28	*DO6	Output device selection 6	0002h		○	○	○	○	○	○	○
PD29	*DIF	Input filter setting	0004h		○	○	○	○	○	○	○
PD30	*DOP1	Function selection D-1	0000h		○	○	○	○	○	○	○
PD31	*DOP2	Function selection D-2	0000h		○	○	○	○	○	○	○
PD32	*DOP3	Function selection D-3	0000h		○	○	○	○	○	○	○
PD33	*DOP4	Function selection D-4	0000h		○	○	○	○	○	○	○

7. PARAMETERS

No.	Symbol	Name	Initial value	Unit	Operation mode				Control mode		
					Standard	Full.	Lin.	DD	CP/BCD	CL	PS
PD34	DOP5	Function selection D-5	0000h		○	○	○	○	○	○	○
PD35		For manufacturer setting	0000h		○	○	○	○	○	○	○
PD36			0000h		○	○	○	○	○	○	○
PD37			0000h		○	○	○	○	○	○	○
PD38			0		○	○	○	○	○	○	○
PD39			0		○	○	○	○	○	○	○
PD40			0		○	○	○	○	○	○	○
PD41	*DIA3	Input signal automatic on selection 3	0000h		○	○	○	○	○	○	○
PD42	*DIA4	Input signal automatic on selection 4	0000h		○	○	○	○	○	○	○
PD43	*DI11L	Input device selection 11L	0000h		○	○	○	○	○	○	○
PD44	*DI11H	Input device selection 11H	3A00h		○	○	○	○	○	○	○
PD45	*DI12L	Input device selection 12L	0000h		○	○	○	○	○	○	○
PD46	*DI12H	Input device selection 12H	3B00h		○	○	○	○	○	○	○
PD47	*DO7	Output device selection 7	0000h		○	○	○	○	○	○	○
PD48		For manufacturer setting	0000h		○	○	○	○	○	○	○

7.1.5 Extension setting 2 parameters ([Pr. PE_ _])

POINT
<ul style="list-style-type: none"> ● The following parameter cannot be used in the positioning mode. <ul style="list-style-type: none"> ▪ [Pr. PE01 Fully closed loop function selection 1]

No.	Symbol	Name	Initial value	Unit	Operation mode				Control mode		
					Standard	Full.	Lin.	DD	CP/BCD	CL	PS
PE01	*FCT1	Fully closed loop function selection 1	0000h		○	○	○	○	○	○	○
PE02		For manufacturer setting	0000h		○	○	○	○	○	○	○
PE03	*FCT2	Fully closed loop function selection 2	0003h		○	○	○	○	○	○	○
PE04	*FBN	Fully closed loop control - Feedback pulse electronic gear 1 - Numerator	1		○	○	○	○	○	○	○
PE05	*FBD	Fully closed loop control - Feedback pulse electronic gear 1 - Denominator	1		○	○	○	○	○	○	○
PE06	BC1	Fully closed loop control - Speed deviation error detection level	400	[r/min]	○	○	○	○	○	○	○
PE07	BC2	Fully closed loop control - Position deviation error detection level	100	[kpulse]	○	○	○	○	○	○	○
PE08	DUF	Fully closed loop dual feedback filter	10	[rad/s]	○	○	○	○	○	○	○
PE09		For manufacturer setting	0000h		○	○	○	○	○	○	○
PE10	FCT3	Fully closed loop function selection 3	0000h		○	○	○	○	○	○	○
PE11		For manufacturer setting	0000h		○	○	○	○	○	○	○
PE12			0000h		○	○	○	○	○	○	○
PE13			0000h		○	○	○	○	○	○	○
PE14			0111h		○	○	○	○	○	○	○
PE15			20		○	○	○	○	○	○	○
PE16			0000h		○	○	○	○	○	○	○
PE17			0000h		○	○	○	○	○	○	○
PE18			0000h		○	○	○	○	○	○	○
PE19			0000h		○	○	○	○	○	○	○
PE20			0000h		○	○	○	○	○	○	○

7. PARAMETERS

No.	Symbol	Name	Initial value	Unit	Operation mode				Control mode		
					Standard	Full.	Lin.	DD	CP/BCD	CL	PS
PE21		For manufacturer setting	0000h								
PE22			0000h								
PE23			0000h								
PE24			0000h								
PE25			0000h								
PE26			0000h								
PE27			0000h								
PE28			0000h								
PE29			0000h								
PE30			0000h								
PE31			0000h								
PE32			0000h								
PE33			0000h								
PE34	*FBN2	Fully closed loop control - Feedback pulse electronic gear 2 - Numerator	1			○			○	○	
PE35	*FBD2	Fully closed loop control - Feedback pulse electronic gear 2 - Denominator	1			○			○	○	
PE36		For manufacturer setting	0.0								
PE37			0.00								
PE38			0.00								
PE39			20								
PE40			0000h								
PE41	EOP3	Function selection E-3	0000h			○	○	○	○	○	○
PE42		For manufacturer setting	0								
PE43			0.0								
PE44	LMCP	Lost motion compensation positive-side compensation value selection	0	[0.01%]		○	○	○	○	○	○
PE45	LMCN	Lost motion compensation negative-side compensation value selection	0	[0.01%]		○	○	○	○	○	○
PE46	LMFLT	Lost motion filter setting	0	[0.1 ms]		○	○	○	○	○	○
PE47	TOF	Torque offset	0	[0.01%]		○	○		○	○	○
PE48	*LMOP	Lost motion compensation function selection	0000h			○	○	○	○	○	○
PE49	LMCD	Lost motion compensation timing	0	[0.1 ms]		○	○	○	○	○	○
PE50	LMCT	Lost motion compensation non-sensitive band	0	[pulse]/ [kpulse]		○	○	○	○	○	○
PE51		For manufacturer setting	0000h								
PE52			0000h								
PE53			0000h								
PE54			0000h								
PE55			0000h								
PE56			0000h								
PE57			0000h								
PE58			0000h								
PE59			0000h								
PE60			0000h								
PE61			0.00								
PE62			0.00								
PE63			0.00								
PE64			0.00								

7. PARAMETERS

7.1.6 Extension setting 3 parameters ([Pr. PF__])

POINT
<p>●The following parameters are used for Modbus-RTU communication. For details, refer to "MR-J4-_A_-RJ Servo Amplifier Instruction Manual (Modbus-RTU communication)".</p> <ul style="list-style-type: none"> ▪ [Pr. PF45 Function selection F-12] ▪ [Pr. PF46 Modbus-RTU communication time-out selection]

No.	Symbol	Name	Initial value	Unit	Operation mode				Control mode			
					Standard	Fuli.	Lin.	DD	CP/BCD	CL	PS	
PF01		For manufacturer setting	0000h									
PF02			0000h									
PF03			0000h									
PF04			0									
PF05			0									
PF06			0000h									
PF07			1									
PF08			1									
PF09	*FOP5	Function selection F-5	0000h		○	○			○	○	○	
PF10		For manufacturer setting	0000h									
PF11			0000h									
PF12			10000									
PF13			100									
PF14			100									
PF15	DBT	Electronic dynamic brake operating time	2000	[ms]		○	○		○	○	○	
PF16		For manufacturer setting	0000h									
PF17			10									
PF18			0000h									
PF19			0000h									
PF20			0000h									
PF21	DRT	Drive recorder switching time setting	0	[s]		○	○	○	○	○	○	○
PF22		For manufacturer setting	200									
PF23	OSCL1	Vibration tough drive - Oscillation detection level	50	[%]		○	○	○	○	○	○	○
PF24	*OSCL2	Vibration tough drive function selection	0000h			○	○	○	○	○	○	○
PF25	CVAT	SEMI-F47 function - Instantaneous power failure detection time	200	[ms]		○	○	○	○	○	○	○
PF26		For manufacturer setting	0									
PF27			0									
PF28			0									
PF29			0000h									
PF30			0									
PF31	FRIC	Machine diagnosis function - Friction judgment speed	0	[r/min]/ [mm/s]		○	○	○	○	○	○	○
PF32		For manufacturer setting	50									
PF33			0000h									
PF34	*SOP3	RS-422 communication function selection 3	0000h			○	○	○	○	○	○	○

7. PARAMETERS

No.	Symbol	Name	Initial value	Unit	Operation mode				Control mode		
					Standard	Full.	Lin.	DD	CP/BCD	CL	PS
PF35		For manufacturer setting	0000h								
PF36			0000h								
PF37			0000h								
PF38			0000h								
PF39			0000h								
PF40			0								
PF41			0								
PF42			0								
PF43			0								
PF44			0								
PF45	*FOP12	Function selection F-12	0000h								
PF46	MIC	Modbus-RTU communication time out selection	0								
PF47		For manufacturer setting	0000h								
PF48			0000h								

7.1.7 Linear servo motor/DD motor setting parameters ([Pr. PL_ _])

No.	Symbol	Name	Initial value	Unit	Operation mode				Control mode		
					Standard	Full.	Lin.	DD	CP/BCD	CL	PS
PL01	*LIT1	Linear servo motor/DD motor function selection 1	0301h				○	○	○	○	○
PL02	*LIM	Linear encoder resolution - Numerator	1000	[μ m]			○	○	○	○	○
PL03	*LID	Linear encoder resolution - Denominator	1000	[μ m]			○	○	○	○	○
PL04	*LIT2	Linear servo motor/DD motor function selection 2	0003h				○	○	○	○	○
PL05	LB1	Position deviation error detection level	0	[mm]/ [0.01rev]			○	○	○	○	○
PL06	LB2	Speed deviation error detection level	0	[r/min]/ [mm/s]			○	○	○	○	○
PL07	LB3	Torque/thrust deviation error detection level	100	[%]			○	○	○	○	○
PL08	*LIT3	Linear servo motor/DD motor function selection 3	0010h				○	○	○	○	○
PL09	LPWM	Magnetic pole detection voltage level	30	[%]			○	○	○	○	○
PL10		For manufacturer setting	5								
PL11			100								
PL12			500								
PL13			0000h								
PL14			0000h								
PL15			20								
PL16			0								
PL17	LTSTS		Magnetic pole detection - Minute position detection method - Function selection	0000h				○	○	○	○
PL18	IDLV	Magnetic pole detection - Minute position detection method - Identification signal amplitude	0	[%]			○	○	○	○	○
PL19		For manufacturer setting	0								
PL20			0								
PL21			0								
PL22			0								
PL23			0000h								
PL24			0								
PL25			0000h								
PL26			0000h								
PL27			0000h								

7. PARAMETERS

No.	Symbol	Name	Initial value	Unit	Operation mode				Control mode		
					Standard	Full.	Lin.	DD	CP/BCD	CL	PS
PL28		For manufacturer setting	0000h								
PL29			0000h								
PL30			0000h								
PL31			0000h								
PL32			0000h								
PL33			0000h								
PL34			0000h								
PL35			0000h								
PL36			0000h								
PL37			0000h								
PL38			0000h								
PL39			0000h								
PL40			0000h								
PL41			0000h								
PL42			0000h								
PL43			0000h								
PL44			0000h								
PL45			0000h								
PL46			0000h								
PL47		0000h									
PL48		0000h									

7.1.8 Option setting parameters ([Pr. Po_ _])

No.	Symbol	Name	Initial value	Unit	Operation mode				Control mode		
					Standard	Full.	Lin.	DD	CP/BCD	CL	PS
Po01		For manufacturer setting	0000h								
Po02	*ODI1	MR-D01 input device selection 1	0302h		○	○	○	○	○	○	○
Po03	*ODI2	MR-D01 input device selection 2	0905h		○	○	○	○	○	○	○
Po04	*ODI3	MR-D01 input device selection 3	2524h		○	○	○	○	○	○	○
Po05	*ODI4	MR-D01 input device selection 4	2026h		○	○	○	○	○	○	○
Po06	*ODI5	MR-D01 input device selection 5	0427h		○	○	○	○	○	○	○
Po07	*ODI6	MR-D01 input device selection 6	0807h		○	○	○	○	○	○	○
Po08	*ODO1	MR-D01 output device selection 1	2726h		○	○	○	○	○	○	○
Po09	*ODO2	MR-D01 output device selection 2	0423h		○	○	○	○	○	○	○
Po10	*OOP1	Function selection O-1	2001h		○	○	○	○	○	○	○
Po11	*OOP2	Function selection O-2	0000h		○	○	○	○	○	○	○
Po12	*OOP3	Function selection O-3	0000h		○	○	○	○	○	○	○
Po13	*OMOD1	MR-D01 analog monitor 1 output selection	0000h		○	○	○	○	○	○	○
Po14	*OMOD2	MR-D01 analog monitor 2 output selection	0000h		○	○	○	○	○	○	○
Po15	OMO1	MR-D01 analog monitor 1 offset	0	[mV]	○	○	○	○	○	○	○
Po16	OMO2	MR-D01 analog monitor 2 offset	0	[mV]	○	○	○	○	○	○	○
Po17		For manufacturer setting	0000h								
Po18			0000h								
Po19			0000h								
Po20			0000h								
Po21	OVCO	MR-D01 override offset	0	[mV]	○	○	○	○	○	○	○
Po22	OTLO	MR-D01 override offset	0	[mV]	○	○	○	○	○	○	○

7. PARAMETERS

No.	Symbol	Name	Initial value	Unit	Operation mode				Control mode		
					Standard	Full.	Lin.	DD	CP/BCD	CL	PS
Po23		For manufacturer setting	0000h								
Po24			0000h								
Po25			0000h								
Po26			0000h								
Po27	*ODI7	MR-D01 input device selection 7	2D2Ch								
Po28	*ODI8	MR-D01 input device selection 8	002Eh								
Po29		For manufacturer setting	0000h								
Po30			0000h								
Po31			0000h								
Po32			0000h								

7.1.9 Positioning control parameters ([Pr. PT_ _])

POINT
<p>● The following parameters are used for Modbus-RTU communication. For details, refer to "MR-J4- _A_ -RJ Servo Amplifier Instruction Manual (Modbus-RTU communication)".</p> <p>▪ [Pr. PT45 Home position return type 2]</p>

No.	Symbol	Name	Initial value	Unit	Operation mode				Control mode		
					Standard	Full.	Lin.	DD	CP/BCD	CL	PS
PT01	*CTY	Command mode selection	0000h		○	○	○	○	○	○	○
PT02	*TOP1	Function selection T-1	0000h		○	○	○	○	○	○	○
PT03	*FTY	Feeding function selection	0000h		○	○	○	○	○	○	○
PT04	*ZTY	Home position return type	0010h		○	○	○	○	○	○	○
PT05	ZRF	Home position return speed	100	[r/min]/[mm/s]	○	○	○	○	○	○	○
PT06	CRF	Creep speed	10	[r/min]/ [mm/s]	○	○	○	○	○	○	○
PT07	ZST	Home position shift distance	0	[μm]/ 10 ⁻⁴ [inch]/ 10 ⁻³ [degree]/ [pulse]	○	○	○	○	○	○	○
PT08	*ZPS	Home position return position data	0	10 ^{STM} [μm]/ 10 ^(STM-4) [inch]/ 10 ⁻³ [degree]/ [pulse]	○	○	○	○	○	○	○
PT09	DCT	Travel distance after proximity dog	1000	10 ^{STM} [μm]/ 10 ^(STM-4) [inch]/ 10 ⁻³ [degree]/ [pulse]	○	○	○	○	○	○	○
PT10	ZTM	Stopper type home position return stopper time	100	[ms]	○	○	○	○	○	○	○
PT11	ZTT	Stopper type home position return torque limit value	15.0	[%]	○	○	○	○	○	○	○
PT12	CRP	Rough match output range	0	10 ^{STM} [μm]/ 10 ^(STM-4) [inch]/ 10 ⁻³ [degree]/ [pulse]	○	○	○	○	○	○	○
PT13	JOG	JOG operation	100	[r/min]/ [mm/s]	○	○	○	○	○	○	○
PT14	*BKC	Backlash compensation	0	[pulse]	○	○	○	○	○	○	○

7. PARAMETERS

No.	Symbol	Name	Initial value	Unit	Operation mode				Control mode		
					Standard	Fuli.	Lin.	DD	CP/BCD	CL	PS
PT15	LMPL	Software limit +	0	10 ^{STM} [μm]/ 10 ^(STM-4) [inch]/ 10 ⁻³ [degree]/ [pulse]	<input type="checkbox"/>	<input type="checkbox"/>	<input type="checkbox"/>	<input type="checkbox"/>	<input type="checkbox"/>	<input type="checkbox"/>	
PT16	LMPH										
PT17	LMNL	Software limit -	0	10 ^{STM} [μm]/ 10 ^(STM-4) [inch]/ 10 ⁻³ [degree]/ [pulse]	<input type="checkbox"/>	<input type="checkbox"/>	<input type="checkbox"/>	<input type="checkbox"/>	<input type="checkbox"/>	<input type="checkbox"/>	
PT18	LMNH										
PT19	*LPPL	Position range output address +	0	10 ^{STM} [μm]/ 10 ^(STM-4) [inch]/ 10 ⁻³ [degree]/ [pulse]	<input type="checkbox"/>	<input type="checkbox"/>	<input type="checkbox"/>	<input type="checkbox"/>	<input type="checkbox"/>	<input type="checkbox"/>	
PT20	*LPPH										
PT21	*LNPL	Position range output address -	0	10 ^{STM} [μm]/ 10 ^(STM-4) [inch]/ 10 ⁻³ [degree]/ [pulse]	<input type="checkbox"/>	<input type="checkbox"/>	<input type="checkbox"/>	<input type="checkbox"/>	<input type="checkbox"/>	<input type="checkbox"/>	
PT22	*LNPH										
PT23	OUT1	OUT1 output setting time	0	[ms]	<input type="checkbox"/>	<input type="checkbox"/>	<input type="checkbox"/>	<input type="checkbox"/>	<input type="checkbox"/>	<input type="checkbox"/>	<input type="checkbox"/>
PT24	OUT2	OUT2 output setting time	0	[ms]	<input type="checkbox"/>	<input type="checkbox"/>	<input type="checkbox"/>	<input type="checkbox"/>	<input type="checkbox"/>	<input type="checkbox"/>	<input type="checkbox"/>
PT25	OUT3	OUT3 output setting time	0	[ms]	<input type="checkbox"/>	<input type="checkbox"/>	<input type="checkbox"/>	<input type="checkbox"/>	<input type="checkbox"/>	<input type="checkbox"/>	<input type="checkbox"/>
PT26	*TOP2	Function selection T-2	0000h		<input type="checkbox"/>	<input type="checkbox"/>	<input type="checkbox"/>	<input type="checkbox"/>	<input type="checkbox"/>	<input type="checkbox"/>	<input type="checkbox"/>
PT27	*ODM	Operation mode selection	0000h		<input type="checkbox"/>	<input type="checkbox"/>	<input type="checkbox"/>	<input type="checkbox"/>	<input type="checkbox"/>	<input type="checkbox"/>	<input type="checkbox"/>
PT28	*STN	Number of stations per rotation	8	[stations]	<input type="checkbox"/>	<input type="checkbox"/>	<input type="checkbox"/>	<input type="checkbox"/>	<input type="checkbox"/>	<input type="checkbox"/>	<input type="checkbox"/>
PT29	*TOP3	Function selection T-3	0000h		<input type="checkbox"/>	<input type="checkbox"/>	<input type="checkbox"/>	<input type="checkbox"/>	<input type="checkbox"/>	<input type="checkbox"/>	<input type="checkbox"/>
PT30	MSTL	Mark sensor stop travel distance	0	10 ^{STM} [μm]/ 10 ^(STM-4) [inch]/ 10 ⁻³ [degree]/ [pulse]	<input type="checkbox"/>	<input type="checkbox"/>	<input type="checkbox"/>	<input type="checkbox"/>	<input type="checkbox"/>	<input type="checkbox"/>	
PT31	MSTH		0		<input type="checkbox"/>	<input type="checkbox"/>	<input type="checkbox"/>	<input type="checkbox"/>	<input type="checkbox"/>	<input type="checkbox"/>	
PT32		For manufacturer setting	0000h								
PT33			0000h								
PT34	*PDEF	Point table/program default	0000h		<input type="checkbox"/>	<input type="checkbox"/>	<input type="checkbox"/>	<input type="checkbox"/>	<input type="checkbox"/>	<input type="checkbox"/>	<input type="checkbox"/>
PT35	*TOP5	Function selection T-5	0000h		<input type="checkbox"/>	<input type="checkbox"/>	<input type="checkbox"/>	<input type="checkbox"/>	<input type="checkbox"/>	<input type="checkbox"/>	<input type="checkbox"/>
PT36		For manufacturer setting	0000h								
PT37			10								
PT38	*TOP7	Function selection T-7	0000h		<input type="checkbox"/>	<input type="checkbox"/>	<input type="checkbox"/>	<input type="checkbox"/>	<input type="checkbox"/>	<input type="checkbox"/>	<input type="checkbox"/>
PT39	INT	Torque limit delay time	100	[ms]	<input type="checkbox"/>	<input type="checkbox"/>	<input type="checkbox"/>	<input type="checkbox"/>	<input type="checkbox"/>	<input type="checkbox"/>	<input type="checkbox"/>
PT40	*SZS	Station home position shift distance	0	[pulse]	<input type="checkbox"/>	<input type="checkbox"/>	<input type="checkbox"/>	<input type="checkbox"/>	<input type="checkbox"/>	<input type="checkbox"/>	<input type="checkbox"/>
PT41	ORP	Home position return inhibit function selection	0000h		<input type="checkbox"/>	<input type="checkbox"/>	<input type="checkbox"/>	<input type="checkbox"/>	<input type="checkbox"/>	<input type="checkbox"/>	<input type="checkbox"/>
PT42	*OVM	Digital override minimum multiplication	0	[%]	<input type="checkbox"/>	<input type="checkbox"/>	<input type="checkbox"/>	<input type="checkbox"/>	<input type="checkbox"/>	<input type="checkbox"/>	<input type="checkbox"/>
PT43	*OVS	Digital override pitch width	0	[%]	<input type="checkbox"/>	<input type="checkbox"/>	<input type="checkbox"/>	<input type="checkbox"/>	<input type="checkbox"/>	<input type="checkbox"/>	<input type="checkbox"/>
PT44		For manufacturer setting	0000h		<input type="checkbox"/>	<input type="checkbox"/>	<input type="checkbox"/>	<input type="checkbox"/>	<input type="checkbox"/>	<input type="checkbox"/>	<input type="checkbox"/>
PT45	*CZTY	Home position return type 2	0000h		<input type="checkbox"/>	<input type="checkbox"/>	<input type="checkbox"/>	<input type="checkbox"/>	<input type="checkbox"/>	<input type="checkbox"/>	<input type="checkbox"/>
PT46		For manufacturer setting	0000h								
PT47			0000h								
PT48			0000h								

7.2 Detailed list of parameters

POINT
● Set a value to each "x" in the "Setting digit" columns.

7. PARAMETERS

7.2.1 Basic setting parameters ([Pr. PA_ _])

No./ symbol/name	Setting digit	Function	Initial value [unit]	Control mode		
				CP/BCD	OL	P.S
PA01 *STY Operation mode	__ _ x	Control mode selection Select a control mode. 0 to 5: Not used for positioning mode. 6: Positioning mode (point table method) 7: Positioning mode (program method) 8: Positioning mode (indexer method)	0h	○	○	○
	__ x _	Operation mode selection 0: Standard control mode 1: Fully closed loop control mode 4: Linear servo motor control mode 6: DD motor control mode (except 400 V class servo amplifiers) The following settings will trigger [AL. 37 Parameter error]. • A value is set other than "0", "1", "4", and "6" to this digit. • "1" or "4" is set to this digit with the indexer method. • "1" or "4" is set to this digit when "Position data unit" is set to [degree] in [Pr. PT01]. For MR-J4-03A6-RJ servo amplifiers, this digit cannot be used other than the initial value.	0h	○	○	○
	_ x _ _	For manufacturer setting	0h			
	x _ _ _		1h			
PA02 *REG Regenerative option	__ x x	Regenerative option Select a regenerative option. Incorrect setting may cause the regenerative option to burn. If a selected regenerative option is not for use with the servo amplifier, [AL. 37 Parameter error] occurs. 00: Regenerative option is not used. • For the servo amplifiers of 100 W, a regenerative resistor is not used. • For servo amplifier of 0.2 kW to 7 kW, built-in regenerative resistor is used. • Supplied regenerative resistors or regenerative option is used with the servo amplifier of 11 kW to 22 kW. 01: FR-RC-(H)/FR-CV-(H)/FR-BU2-(H) When you use FR-RC-(H) or FR-CV-(H), select "Mode 2 (_ _ _ 1)" of "Undervoltage alarm detection mode selection" in [Pr. PC27]. 02: MR-RB032 03: MR-RB12 04: MR-RB32 05: MR-RB30 06: MR-RB50 (Cooling fan is required.) 08: MR-RB31 09: MR-RB51 (Cooling fan is required.) 0B: MR-RB3N 0C: MR-RB5N (Cooling fan is required.) 80: MR-RB1H-4 81: MR-RB3M-4 (Cooling fan is required.) 82: MR-RB3G-4 (Cooling fan is required.) 83: MR-RB5G-4 (Cooling fan is required.) 84: MR-RB34-4 (Cooling fan is required.) 85: MR-RB54-4 (Cooling fan is required.) 91: MR-RB3U-4 (Cooling fan is required.) 92: MR-RB5U-4 (Cooling fan is required.) FA: When the supplied regenerative resistors or the regenerative option is cooled by the cooling fan to increase the ability with the servo amplifier of 11 kW to 22 kW. For MR-J4-03A6-RJ servo amplifiers, this digit cannot be used other than the initial value.	00h	○	○	○
	_ x _ _	For manufacturer setting	0h			
	x _ _ _		0h			

7. PARAMETERS

No./ symbol/name	Setting digit	Function	Initial value [unit]	Control mode																
				CP/BCD	CL	PS														
PA03 *ABS Absolute position detection system	___x	Absolute position detection system selection Set this digit when using the absolute position detection system. 0: Disabled (incremental system) 1: Enabled (absolute position detection system) 2: Not used for positioning mode. Setting a value other than "0" and "1" will trigger [AL. 37 Parameter error].	0h	<input type="radio"/>	<input type="radio"/>	<input type="radio"/>														
	__x_	For manufacturer setting	0h	<input type="checkbox"/>	<input type="checkbox"/>	<input type="checkbox"/>														
	_x__		0h	<input type="checkbox"/>	<input type="checkbox"/>	<input type="checkbox"/>														
	x___		0h	<input type="checkbox"/>	<input type="checkbox"/>	<input type="checkbox"/>														
PA04 *AOP1 Function selection A-1	___x	For manufacturer setting	0h	<input type="checkbox"/>	<input type="checkbox"/>	<input type="checkbox"/>														
	__x_		0h	<input type="checkbox"/>	<input type="checkbox"/>	<input type="checkbox"/>														
	_x__		0h	<input type="checkbox"/>	<input type="checkbox"/>	<input type="checkbox"/>														
	x___	Forced stop deceleration function selection 0: Forced stop deceleration function disabled (EM1) 2: Forced stop deceleration function enabled (EM2) Refer to table 7.1 for details.	2h	<input type="radio"/>	<input type="radio"/>	<input type="radio"/>														
<p>Table 7.1 Deceleration method</p> <table border="1"> <thead> <tr> <th rowspan="2">Setting value</th> <th rowspan="2">EM2/EM1</th> <th colspan="2">Deceleration method</th> </tr> <tr> <th>EM2 or EM1 is off</th> <th>Alarm occurred</th> </tr> </thead> <tbody> <tr> <td>0 ___</td> <td>EM1</td> <td>MBR (Electromagnetic brake interlock) turns off without the forced stop deceleration.</td> <td>MBR (Electromagnetic brake interlock) turns off without the forced stop deceleration.</td> </tr> <tr> <td>2 ___</td> <td>EM2</td> <td>MBR (Electromagnetic brake interlock) turns off after the forced stop deceleration.</td> <td>MBR (Electromagnetic brake interlock) turns off after the forced stop deceleration.</td> </tr> </tbody> </table>							Setting value	EM2/EM1	Deceleration method		EM2 or EM1 is off	Alarm occurred	0 ___	EM1	MBR (Electromagnetic brake interlock) turns off without the forced stop deceleration.	MBR (Electromagnetic brake interlock) turns off without the forced stop deceleration.	2 ___	EM2	MBR (Electromagnetic brake interlock) turns off after the forced stop deceleration.	MBR (Electromagnetic brake interlock) turns off after the forced stop deceleration.
Setting value	EM2/EM1	Deceleration method																		
		EM2 or EM1 is off	Alarm occurred																	
0 ___	EM1	MBR (Electromagnetic brake interlock) turns off without the forced stop deceleration.	MBR (Electromagnetic brake interlock) turns off without the forced stop deceleration.																	
2 ___	EM2	MBR (Electromagnetic brake interlock) turns off after the forced stop deceleration.	MBR (Electromagnetic brake interlock) turns off after the forced stop deceleration.																	

7. PARAMETERS

No./ symbol/name	Setting digit	Function	Initial value [unit]	Control mode										
				CP/BCD	CL	PS								
PA06 *CMX Electronic gear numerator (command pulse multiplication numerator)		<p>Set an electronic gear numerator. (Refer to section 7.3.1.)</p> <p>To enable the parameter values in the positioning mode, cycle the power after setting.</p> <p>To enable the parameter, select "Electronic gear (0 ___)", "J3 electronic gear setting value compatibility mode (2 ___)", or "J2S electronic gear setting value compatibility mode (3 ___)" of "Electronic gear selection" in [Pr. PA21]. For MR-J4-03A6-RJ servo amplifiers, "J3 electronic gear setting value compatibility mode (2 ___)" and "J2S electronic gear setting value compatibility mode (3 ___)" cannot be selected.</p> <p>Set the electronic gear within the following range. Setting out of the range will trigger [AL. 37 Parameter error].</p> <table border="1" style="margin: 10px auto;"> <thead> <tr> <th>Pr. PA21</th> <th>Electronic gear setting range</th> </tr> </thead> <tbody> <tr> <td>0 ___</td> <td>1/865 < CMX/CDV < 271471</td> </tr> <tr> <td>2 ___</td> <td>1/13825 < CMX/CDV < 16967</td> </tr> <tr> <td>3 ___</td> <td>1/27649 < CMX/CDV < 8484</td> </tr> </tbody> </table> <p>Setting range: 1 to 16777215</p>	Pr. PA21	Electronic gear setting range	0 ___	1/865 < CMX/CDV < 271471	2 ___	1/13825 < CMX/CDV < 16967	3 ___	1/27649 < CMX/CDV < 8484	1	○	○	
Pr. PA21	Electronic gear setting range													
0 ___	1/865 < CMX/CDV < 271471													
2 ___	1/13825 < CMX/CDV < 16967													
3 ___	1/27649 < CMX/CDV < 8484													
PA06 *CMX Number of gear teeth on machine side		<p>Set the number of gear teeth on machine side. (Refer to section 7.3.2.)</p> <p>To enable the parameter values in the positioning mode, cycle the power after setting.</p> <p>Set the electronic gear within the following range.</p> <p>(1) $1 \leq CMX \leq 16384, 1 \leq CDV \leq 16384$</p> <p>(2) $\frac{1}{9999} \leq \frac{CMX}{CDV} \leq 9999$</p> <p>(3) $CDV \times STN \leq 32767$ (STN: Number of stations per rotation [Pr. PT28])</p> <p>(4) $CMX \times CDV \leq 100000$</p> <p>Setting out of the range will trigger [AL. 37 Parameter error].</p> <p>When a small value is set to the electronic gear ratio with the manual operation mode, the servo motor may not drive at the set servo motor speed.</p> <p>Travel distance of 1 station = Pt (servo motor resolution) $\times \frac{1}{STN} \times \frac{CMX}{CDV}$</p> <p>Setting range: 1 to 16777215</p>	1			○								
PA07 *CDV Electronic gear denominator (command pulse multiplication denominator)		<p>Set an electronic gear denominator. (Refer to section 7.3.1.)</p> <p>To enable the parameter values in the positioning mode, cycle the power after setting.</p> <p>To enable the parameter, select "Electronic gear (0 ___)", "J3 electronic gear setting value compatibility mode (2 ___)", or "J2S electronic gear setting value compatibility mode (3 ___)" of "Electronic gear selection" in [Pr. PA21]. For MR-J4-03A6-RJ servo amplifiers, "J3 electronic gear setting value compatibility mode (2 ___)" and "J2S electronic gear setting value compatibility mode (3 ___)" cannot be selected.</p> <p>Set the electronic gear within the range of [Pr. PA06].</p> <p>Setting out of the range will trigger [AL. 37 Parameter error].</p> <p>Setting range: 1 to 16777215</p>	1	○	○									
PA07 *CDV Number of gear teeth on servo motor side		<p>Set the number of gear teeth on servo motor side. (Refer to section 7.3.2.)</p> <p>To enable the parameter values in the positioning mode, cycle the power after setting.</p> <p>Set the electronic gear within the range of [Pr. PA06].</p> <p>Setting out of the range will trigger [AL. 37 Parameter error].</p> <p>Setting range: 1 to 16777215</p>	1			○								

7. PARAMETERS

No./ symbol/name	Setting digit	Function	Initial value [unit]	Control mode																				
				CP/BCD	CL	PS																		
PA08 ATU Auto tuning mode	___x	Gain adjustment mode selection Select the gain adjustment mode. 0: 2 gain adjustment mode 1 (interpolation mode) 1: Auto tuning mode 1 2: Auto tuning mode 2 3: Manual mode 4: 2 gain adjustment mode 2 Refer to table 7.2 for details.	1h	○	○	○																		
	__x_	For manufacturer setting	0h	□	□	□																		
	_x__		0h	□	□	□																		
	x___		0h	□	□	□																		
<p>Table 7.2 Gain adjustment mode selection</p> <table border="1"> <thead> <tr> <th>Setting value</th> <th>Gain adjustment mode</th> <th>Automatically adjusted parameter</th> </tr> </thead> <tbody> <tr> <td>___0</td> <td>2 gain adjustment mode 1 (interpolation mode)</td> <td>[Pr. PB06 Load to motor inertia ratio] [Pr. PB08 Position loop gain] [Pr. PB09 Speed loop gain] [Pr. PB10 Speed integral compensation]</td> </tr> <tr> <td>___1</td> <td>Auto tuning mode 1</td> <td>[Pr. PB06 Load to motor inertia ratio] [Pr. PB07 Model loop gain] [Pr. PB08 Position loop gain] [Pr. PB09 Speed loop gain] [Pr. PB10 Speed integral compensation]</td> </tr> <tr> <td>___2</td> <td>Auto tuning mode 2</td> <td>[Pr. PB07 Model loop gain] [Pr. PB08 Position loop gain] [Pr. PB09 Speed loop gain] [Pr. PB10 Speed integral compensation]</td> </tr> <tr> <td>___3</td> <td>Manual mode</td> <td></td> </tr> <tr> <td>___4</td> <td>2 gain adjustment mode 2</td> <td>[Pr. PB08 Position loop gain] [Pr. PB09 Speed loop gain] [Pr. PB10 Speed integral compensation]</td> </tr> </tbody> </table>							Setting value	Gain adjustment mode	Automatically adjusted parameter	___0	2 gain adjustment mode 1 (interpolation mode)	[Pr. PB06 Load to motor inertia ratio] [Pr. PB08 Position loop gain] [Pr. PB09 Speed loop gain] [Pr. PB10 Speed integral compensation]	___1	Auto tuning mode 1	[Pr. PB06 Load to motor inertia ratio] [Pr. PB07 Model loop gain] [Pr. PB08 Position loop gain] [Pr. PB09 Speed loop gain] [Pr. PB10 Speed integral compensation]	___2	Auto tuning mode 2	[Pr. PB07 Model loop gain] [Pr. PB08 Position loop gain] [Pr. PB09 Speed loop gain] [Pr. PB10 Speed integral compensation]	___3	Manual mode		___4	2 gain adjustment mode 2	[Pr. PB08 Position loop gain] [Pr. PB09 Speed loop gain] [Pr. PB10 Speed integral compensation]
Setting value	Gain adjustment mode	Automatically adjusted parameter																						
___0	2 gain adjustment mode 1 (interpolation mode)	[Pr. PB06 Load to motor inertia ratio] [Pr. PB08 Position loop gain] [Pr. PB09 Speed loop gain] [Pr. PB10 Speed integral compensation]																						
___1	Auto tuning mode 1	[Pr. PB06 Load to motor inertia ratio] [Pr. PB07 Model loop gain] [Pr. PB08 Position loop gain] [Pr. PB09 Speed loop gain] [Pr. PB10 Speed integral compensation]																						
___2	Auto tuning mode 2	[Pr. PB07 Model loop gain] [Pr. PB08 Position loop gain] [Pr. PB09 Speed loop gain] [Pr. PB10 Speed integral compensation]																						
___3	Manual mode																							
___4	2 gain adjustment mode 2	[Pr. PB08 Position loop gain] [Pr. PB09 Speed loop gain] [Pr. PB10 Speed integral compensation]																						

7. PARAMETERS

No./ symbol/name	Setting digit	Function	Initial value [unit]	Control mode																																																																																																
				CP/BCD	OL	PS																																																																																														
PA09 RSP Auto tuning response		<p>Set the auto tuning response.</p> <table border="1"> <thead> <tr> <th rowspan="2">Setting value</th> <th colspan="2">Machine characteristic</th> <th rowspan="2">Setting value</th> <th colspan="2">Machine characteristic</th> </tr> <tr> <th>Response</th> <th>Guideline for machine resonance frequency [Hz]</th> <th>Response</th> <th>Guideline for machine resonance frequency [Hz]</th> </tr> </thead> <tbody> <tr> <td>1</td> <td rowspan="19">Low response ↑ ↓ Middle response</td> <td>2.7</td> <td>21</td> <td rowspan="20">Middle response ↑ ↓ High response</td> <td>67.1</td> </tr> <tr><td>2</td><td>3.6</td><td>22</td><td>75.6</td></tr> <tr><td>3</td><td>4.9</td><td>23</td><td>85.2</td></tr> <tr><td>4</td><td>6.6</td><td>24</td><td>95.9</td></tr> <tr><td>5</td><td>10.0</td><td>25</td><td>108.0</td></tr> <tr><td>6</td><td>11.3</td><td>26</td><td>121.7</td></tr> <tr><td>7</td><td>12.7</td><td>27</td><td>137.1</td></tr> <tr><td>8</td><td>14.3</td><td>28</td><td>154.4</td></tr> <tr><td>9</td><td>16.1</td><td>29</td><td>173.9</td></tr> <tr><td>10</td><td>18.1</td><td>30</td><td>195.9</td></tr> <tr><td>11</td><td>20.4</td><td>31</td><td>220.6</td></tr> <tr><td>12</td><td>23.0</td><td>32</td><td>248.5</td></tr> <tr><td>13</td><td>25.9</td><td>33</td><td>279.9</td></tr> <tr><td>14</td><td>29.2</td><td>34</td><td>315.3</td></tr> <tr><td>15</td><td>32.9</td><td>35</td><td>355.1</td></tr> <tr><td>16</td><td>37.0</td><td>36</td><td>400.0</td></tr> <tr><td>17</td><td>41.7</td><td>37</td><td>446.6</td></tr> <tr><td>18</td><td>47.0</td><td>38</td><td>501.2</td></tr> <tr><td>19</td><td>52.9</td><td>39</td><td>571.5</td></tr> <tr> <td>20</td><td></td> <td>59.6</td> <td>40</td><td></td> <td>642.7</td> </tr> </tbody> </table> <p>Setting range: 1 to 40</p>	Setting value	Machine characteristic		Setting value	Machine characteristic		Response	Guideline for machine resonance frequency [Hz]	Response	Guideline for machine resonance frequency [Hz]	1	Low response ↑ ↓ Middle response	2.7	21	Middle response ↑ ↓ High response	67.1	2	3.6	22	75.6	3	4.9	23	85.2	4	6.6	24	95.9	5	10.0	25	108.0	6	11.3	26	121.7	7	12.7	27	137.1	8	14.3	28	154.4	9	16.1	29	173.9	10	18.1	30	195.9	11	20.4	31	220.6	12	23.0	32	248.5	13	25.9	33	279.9	14	29.2	34	315.3	15	32.9	35	355.1	16	37.0	36	400.0	17	41.7	37	446.6	18	47.0	38	501.2	19	52.9	39	571.5	20		59.6	40		642.7	16	<input type="radio"/>	<input type="radio"/>	<input type="radio"/>
Setting value	Machine characteristic			Setting value	Machine characteristic																																																																																															
	Response	Guideline for machine resonance frequency [Hz]	Response		Guideline for machine resonance frequency [Hz]																																																																																															
1	Low response ↑ ↓ Middle response	2.7	21	Middle response ↑ ↓ High response	67.1																																																																																															
2		3.6	22		75.6																																																																																															
3		4.9	23		85.2																																																																																															
4		6.6	24		95.9																																																																																															
5		10.0	25		108.0																																																																																															
6		11.3	26		121.7																																																																																															
7		12.7	27		137.1																																																																																															
8		14.3	28		154.4																																																																																															
9		16.1	29		173.9																																																																																															
10		18.1	30		195.9																																																																																															
11		20.4	31		220.6																																																																																															
12		23.0	32		248.5																																																																																															
13		25.9	33		279.9																																																																																															
14		29.2	34		315.3																																																																																															
15		32.9	35		355.1																																																																																															
16		37.0	36		400.0																																																																																															
17		41.7	37		446.6																																																																																															
18		47.0	38		501.2																																																																																															
19		52.9	39		571.5																																																																																															
20		59.6	40			642.7																																																																																														
PA10 INP In-position range		<p>Set an in-position range per command. To change it to the servo motor encoder pulse unit, set [Pr. PC24].</p> <table border="1"> <thead> <tr> <th>Pr. PA01</th> <th>In-position setting range</th> </tr> </thead> <tbody> <tr> <td>___ 6 (positioning mode (point table method))</td> <td rowspan="2">The range where MEND (Travel completion), PED (Position end) and INP (In-position) are inputted.</td> </tr> <tr> <td>___ 7 (Positioning mode (program method))</td> </tr> <tr> <td>___ 8 (Positioning mode (indexer method))</td> <td>The range where MEND (Travel completion) and INP (In-position) are inputted.</td> </tr> </tbody> </table> <p>The unit will be as follows depending on the positioning mode.</p> <ul style="list-style-type: none"> Point table method or program method When [Pr. PC24] is set to "___ 0", the unit can be changed to [μm], 10-4 [inch], 10-3 [degree], or [pulse] with the setting of [Pr. PT01]. When [Pr. PC24] is set to "___ 1", the unit is fixed to [pulse]. Indexer method Command unit [pulse] (a load-side rotation expressed by the number of encoder resolution pulses) For example, when making an in-position range "± 1 degree" for the rotation angle on the load side, set $4194304 \times (1/360) = 11650$ pulses. <p>Setting range: 0 to 65535</p>	Pr. PA01	In-position setting range	___ 6 (positioning mode (point table method))	The range where MEND (Travel completion), PED (Position end) and INP (In-position) are inputted.	___ 7 (Positioning mode (program method))	___ 8 (Positioning mode (indexer method))	The range where MEND (Travel completion) and INP (In-position) are inputted.	100 Refer to Function column for unit.	<input type="radio"/>	<input type="radio"/>	<input type="radio"/>																																																																																							
Pr. PA01	In-position setting range																																																																																																			
___ 6 (positioning mode (point table method))	The range where MEND (Travel completion), PED (Position end) and INP (In-position) are inputted.																																																																																																			
___ 7 (Positioning mode (program method))																																																																																																				
___ 8 (Positioning mode (indexer method))	The range where MEND (Travel completion) and INP (In-position) are inputted.																																																																																																			

7. PARAMETERS

No./ symbol/name	Setting digit	Function	Initial value [unit]	Control mode		
				CP/BCD	CL	PS
PA11 TLP Forward rotation torque limit/positive direction thrust limit		<p>You can limit the torque or thrust generated by the servo motor. Set the parameter referring to section 3.6.1 (5) of "MR-J4-_A_(-RJ) Servo Amplifier Instruction Manual".</p> <p>When you output torque or thrust with analog monitor output, the larger value of [Pr. PA11 Forward rotation torque limit/positive direction thrust limit value] or [Pr. PA12 Reverse rotation torque limit/negative direction thrust limit value] will be the maximum output voltage (8 V).</p> <p>Set the parameter on the assumption that the maximum torque or thrust is 100.0 [%]. The parameter is for limiting the torque of the servo motor in the CCW power running or CW regeneration, or limiting the thrust of the linear servo motor in the positive direction power running or negative direction regeneration. Set this parameter to "0.0" to generate no torque or thrust.</p> <p>Setting range: 0.0 to 100.0</p>	100.0 [%]	<input type="radio"/>	<input type="radio"/>	<input type="radio"/>
PA12 TLN Reverse rotation torque limit/negative direction thrust limit		<p>You can limit the torque or thrust generated by the servo motor. Set the parameter referring to section 3.6.1 (5) of "MR-J4-_A_(-RJ) Servo Amplifier Instruction Manual".</p> <p>When you output torque or thrust with analog monitor output, the larger value of [Pr. PA11 Forward rotation torque limit/positive direction thrust limit value] or [Pr. PA12 Reverse rotation torque limit/negative direction thrust limit value] will be the maximum output voltage (8 V).</p> <p>Set the parameter on the assumption that the maximum torque or thrust is 100.0 [%]. The parameter is for limiting the torque of the servo motor in the CW power running or CCW regeneration, or limiting the thrust of the linear servo motor in the positive direction power running or negative direction regeneration. Set this parameter to "0.0" to generate no torque or thrust.</p> <p>Setting range: 0.0 to 100.0</p>	100.0 [%]	<input type="radio"/>	<input type="radio"/>	<input type="radio"/>
PA13 *PLSS Command pulse input form	___x	<p>Command input pulse train form selection</p> <p>0: Forward/reverse rotation pulse train</p> <p>1: Signed pulse train</p> <p>2: A-phase/B-phase pulse train (The servo amplifier imports input pulses after multiplying by four.)</p> <p>When connecting the manual pulse generator MR-HDP01 in the positioning mode, set "2" to this digit.</p> <p>Refer to table 7.3 for settings.</p>	0h	<input type="radio"/>	<input type="radio"/>	<input type="radio"/>
	__x_	<p>Pulse train logic selection</p> <p>0: Positive logic</p> <p>1: Negative logic</p> <p>Select the same one as logic of command pulse train from controller to connect. Refer to POINT of section 3.6.1 of "MR-J4-_A_(-RJ) Servo Amplifier Instruction Manual" for logic of MELSEC iQ-R series/MELSEC-Q series/MELSEC-L series/MELSEC-F series. When connecting the manual pulse generator MR-HDP01 in the positioning mode, set "0" to this digit.</p> <p>Refer to table 7.3 for settings.</p>	0h	<input type="radio"/>	<input type="radio"/>	<input type="radio"/>

7. PARAMETERS

No./ symbol/name	Setting digit	Function	Initial value [unit]	Control mode		
				CP/BCD	CL	PS
PA13 *PLSS Command pulse input form	_ x _ _	Command input pulse train filter selection Selecting proper filter enables to enhance noise tolerance. 0: Command input pulse train is 4 Mpulses/s or less. 1: Command input pulse train is 1 Mpulse/s or less. 2: Command input pulse train is 500 kpulses/s or less. 3: Command input pulse train is 200 kpulses/s or less. 1 Mpulse/s or lower commands are supported by "1". When inputting commands over 1 Mpulse/s and 4 Mpulses/s or lower, set "0". When connecting the manual pulse generator MR-HDP01 in the positioning mode, set "2" or "3" to this digit. Incorrect setting may cause the following malfunctions. <ul style="list-style-type: none"> Setting a value higher than actual command will lower noise tolerance. Setting a value lower than actual command will cause a position mismatch. 	1h	○	○	
	x _ _ _	For manufacturer setting	0h			

Table 7.3 Command input pulse train form selection

Setting value		Pulse train form	Forward rotation (positive direction) command	Reverse rotation (negative direction) command
_ _ 1 0	Negative logic	Forward rotation pulse train (positive direction pulse train)	PP	NP
		Reverse rotation pulse train (negative direction pulse train)		
		Signed pulse train	PP	NP
_ _ 1 2		A-phase pulse train B-phase pulse train	PP	NP
_ _ 0 0	Positive logic	Forward rotation pulse train (positive direction pulse train)	PP	NP
		Reverse rotation pulse train (negative direction pulse train)		
		Signed pulse train	PP	NP
_ _ 0 2		A-phase pulse train B-phase pulse train	PP	NP

Arrows in the table indicate the timing of importing pulse trains. A-phase/B-phase pulse trains are imported after they have been multiplied by 4.

When connecting the manual pulse generator MR-HDP01 in the positioning mode, set "_ _ 02h".

7. PARAMETERS

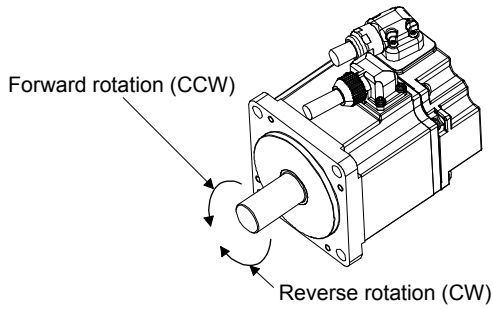
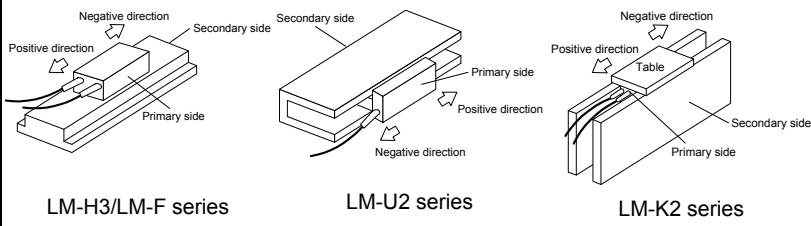
No./ symbol/name	Setting digit	Function	Initial value [unit]	Control mode													
				CP/BCD	CL	PS											
PA14 *POL Rotation direction selection/travel direction selection		<p>Select a rotation direction of the servo motor or travel direction of the linear servo motor for when turning on ST1 (Forward rotation start) or ST2 (Reverse rotation start).</p> <table border="1"> <thead> <tr> <th rowspan="2">Setting value</th> <th colspan="2">Servo motor rotation direction/linear servo motor travel direction</th> </tr> <tr> <th>When positioning address increases</th> <th>When positioning address decreases</th> </tr> </thead> <tbody> <tr> <td>0</td> <td>CCW or positive direction</td> <td>CW or negative direction</td> </tr> <tr> <td>1</td> <td>CW or negative direction</td> <td>CCW or positive direction</td> </tr> </tbody> </table> <p>The following shows the servo motor rotation directions.</p>  <p>The positive/negative directions of the linear servo motor are as follows.</p>  <p>Setting range: 0,1</p>	Setting value	Servo motor rotation direction/linear servo motor travel direction		When positioning address increases	When positioning address decreases	0	CCW or positive direction	CW or negative direction	1	CW or negative direction	CCW or positive direction	0	<input type="radio"/>	<input type="radio"/>	<input type="radio"/>
Setting value	Servo motor rotation direction/linear servo motor travel direction																
	When positioning address increases	When positioning address decreases															
0	CCW or positive direction	CW or negative direction															
1	CW or negative direction	CCW or positive direction															
PA15 *ENR Encoder output pulses		<p>Set the encoder output pulses from the servo amplifier by using the number of output pulses per revolution, dividing ratio, or electronic gear ratio. (after multiplication by 4)</p> <p>Set a numerator of the electronic gear, for when selecting "A-phase/B-phase pulse electronic gear setting (_ _ 3 _)" of "Encoder output pulse setting selection" in [Pr. PC19].</p> <p>The maximum output frequency is 4.6 Mpulses/s. Set the parameter within this range.</p> <p>Setting range: 1 to 4194304</p>	4000 [pulse/ rev]	<input type="radio"/>	<input type="radio"/>	<input type="radio"/>											
PA16 *ENR2 Encoder output pulses 2		<p>Set a denominator of the electronic gear for the A/B-phase pulse output.</p> <p>Set a denominator of the electronic gear, for when selecting "A-phase/B-phase pulse electronic gear setting (_ _ 3 _)" of "Encoder output pulse setting selection" in [Pr. PC19].</p> <p>Setting range: 1 to 4194304</p>	1	<input type="radio"/>	<input type="radio"/>	<input type="radio"/>											

7. PARAMETERS

No./ symbol/name	Setting digit	Function	Initial value [unit]	Control mode																																																
				CP/BCD	CL	PS																																														
PA17 *MSR Servo motor series setting		<p>When using a linear servo motor, select any linear servo motor with [Pr. PA17] and [Pr. PA18]. Set this and [Pr. PA18] at a time. Refer to the following table for settings. This parameter is not available with MR-J4-03A6-RJ servo amplifiers.</p> <table border="1"> <thead> <tr> <th rowspan="2">Linear servo motor series</th> <th rowspan="2">Linear servo motor (primary side)</th> <th colspan="2">Parameter</th> </tr> <tr> <th>[Pr. PA17] setting</th> <th>[Pr. PA18] setting</th> </tr> </thead> <tbody> <tr> <td rowspan="9">LM-H3</td> <td>LM-H3P2A-07P-BSS0</td> <td rowspan="9">00BBh</td> <td>2101h</td> </tr> <tr> <td>LM-H3P3A-12P-CSS0</td> <td>3101h</td> </tr> <tr> <td>LM-H3P3B-24P-CSS0</td> <td>3201h</td> </tr> <tr> <td>LM-H3P3C-36P-CSS0</td> <td>3301h</td> </tr> <tr> <td>LM-H3P3D-48P-CSS0</td> <td>3401h</td> </tr> <tr> <td>LM-H3P7A-24P-ASS0</td> <td>7101h</td> </tr> <tr> <td>LM-H3P7B-48P-ASS0</td> <td>7201h</td> </tr> <tr> <td>LM-H3P7C-72P-ASS0</td> <td>7301h</td> </tr> <tr> <td>LM-H3P7D-96P-ASS0</td> <td>7401h</td> </tr> <tr> <td rowspan="8">LM-U2</td> <td>LM-U2PAB-05M-0SS0</td> <td rowspan="8">00B4h</td> <td>A201h</td> </tr> <tr> <td>LM-U2PAD-10M-0SS0</td> <td>A401h</td> </tr> <tr> <td>LM-U2PAF-15M-0SS0</td> <td>A601h</td> </tr> <tr> <td>LM-U2PBB-07M-1SS0</td> <td>B201h</td> </tr> <tr> <td>LM-U2PBD-15M-1SS0</td> <td>B401h</td> </tr> <tr> <td>LM-U2PBF-22M-1SS0</td> <td>2601h</td> </tr> <tr> <td>LM-U2P2B-40M-2SS0</td> <td>2201h</td> </tr> <tr> <td>LM-U2P2C-60M-2SS0</td> <td>2301h</td> </tr> <tr> <td>LM-U2P2D-80M-2SS0</td> <td>2401h</td> </tr> </tbody> </table>	Linear servo motor series	Linear servo motor (primary side)	Parameter		[Pr. PA17] setting	[Pr. PA18] setting	LM-H3	LM-H3P2A-07P-BSS0	00BBh	2101h	LM-H3P3A-12P-CSS0	3101h	LM-H3P3B-24P-CSS0	3201h	LM-H3P3C-36P-CSS0	3301h	LM-H3P3D-48P-CSS0	3401h	LM-H3P7A-24P-ASS0	7101h	LM-H3P7B-48P-ASS0	7201h	LM-H3P7C-72P-ASS0	7301h	LM-H3P7D-96P-ASS0	7401h	LM-U2	LM-U2PAB-05M-0SS0	00B4h	A201h	LM-U2PAD-10M-0SS0	A401h	LM-U2PAF-15M-0SS0	A601h	LM-U2PBB-07M-1SS0	B201h	LM-U2PBD-15M-1SS0	B401h	LM-U2PBF-22M-1SS0	2601h	LM-U2P2B-40M-2SS0	2201h	LM-U2P2C-60M-2SS0	2301h	LM-U2P2D-80M-2SS0	2401h	0000h	<input type="radio"/>	<input type="radio"/>	
Linear servo motor series	Linear servo motor (primary side)	Parameter																																																		
		[Pr. PA17] setting	[Pr. PA18] setting																																																	
LM-H3	LM-H3P2A-07P-BSS0	00BBh	2101h																																																	
	LM-H3P3A-12P-CSS0		3101h																																																	
	LM-H3P3B-24P-CSS0		3201h																																																	
	LM-H3P3C-36P-CSS0		3301h																																																	
	LM-H3P3D-48P-CSS0		3401h																																																	
	LM-H3P7A-24P-ASS0		7101h																																																	
	LM-H3P7B-48P-ASS0		7201h																																																	
	LM-H3P7C-72P-ASS0		7301h																																																	
	LM-H3P7D-96P-ASS0		7401h																																																	
LM-U2	LM-U2PAB-05M-0SS0	00B4h	A201h																																																	
	LM-U2PAD-10M-0SS0		A401h																																																	
	LM-U2PAF-15M-0SS0		A601h																																																	
	LM-U2PBB-07M-1SS0		B201h																																																	
	LM-U2PBD-15M-1SS0		B401h																																																	
	LM-U2PBF-22M-1SS0		2601h																																																	
	LM-U2P2B-40M-2SS0		2201h																																																	
	LM-U2P2C-60M-2SS0		2301h																																																	
LM-U2P2D-80M-2SS0	2401h																																																			

7. PARAMETERS

No./ symbol/name	Setting digit	Function	Initial value [unit]	Control mode																																																									
				CP/BCD	CL	PS																																																							
PA17 *MSR Servo motor series setting		<table border="1"> <thead> <tr> <th rowspan="2">Linear servo motor series</th> <th rowspan="2">Linear servo motor (primary side)</th> <th colspan="2">Parameter</th> </tr> <tr> <th>[Pr. PA17] setting</th> <th>[Pr. PA18] setting</th> </tr> </thead> <tbody> <tr> <td rowspan="18">LM-F</td> <td>LM-FP2B-06M-1SS0 (natural cooling)</td> <td rowspan="18">00B2h</td> <td>2201h</td> </tr> <tr> <td>LM-FP2D-12M-1SS0 (natural cooling)</td> <td>2401h</td> </tr> <tr> <td>LM-FP2F-18M-1SS0 (natural cooling)</td> <td>2601h</td> </tr> <tr> <td>LM-FP4B-12M-1SS0 (natural cooling)</td> <td>4201h</td> </tr> <tr> <td>LM-FP4D-24M-1SS0 (natural cooling)</td> <td>4401h</td> </tr> <tr> <td>LM-FP4F-36M-1SS0 (natural cooling)</td> <td>4601h</td> </tr> <tr> <td>LM-FP4H-48M-1SS0 (natural cooling)</td> <td>4801h</td> </tr> <tr> <td>LM-FP5H-60M-1SS0 (natural cooling)</td> <td>5801h</td> </tr> <tr> <td>LM-FP2B-06M-1SS0 (liquid-cooling)</td> <td>2202h</td> </tr> <tr> <td>LM-FP2D-12M-1SS0 (liquid-cooling)</td> <td>2402h</td> </tr> <tr> <td>LM-FP2F-18M-1SS0 (liquid-cooling)</td> <td>2602h</td> </tr> <tr> <td>LM-FP4B-12M-1SS0 (liquid-cooling)</td> <td>4202h</td> </tr> <tr> <td>LM-FP4D-24M-1SS0 (liquid-cooling)</td> <td>4402h</td> </tr> <tr> <td>LM-FP4F-36M-1SS0 (liquid-cooling)</td> <td>4602h</td> </tr> <tr> <td>LM-FP4H-48M-1SS0 (liquid-cooling)</td> <td>4802h</td> </tr> <tr> <td>LM-FP5H-60M-1SS0 (liquid-cooling)</td> <td>5802h</td> </tr> <tr> <td rowspan="7">LM-K2</td> <td>LM-K2P1A-01M-2SS1</td> <td rowspan="7">00B8h</td> <td>1101h</td> </tr> <tr> <td>LM-K2P1C-03M-2SS1</td> <td>1301h</td> </tr> <tr> <td>LM-K2P2A-02M-1SS1</td> <td>2101h</td> </tr> <tr> <td>LM-K2P2C-07M-1SS1</td> <td>2301h</td> </tr> <tr> <td>LM-K2P2E-12M-1SS1</td> <td>2501h</td> </tr> <tr> <td>LM-K2P3C-14M-1SS1</td> <td>3301h</td> </tr> <tr> <td>LM-K2P3E-24M-1SS1</td> <td>3501h</td> </tr> </tbody> </table>	Linear servo motor series	Linear servo motor (primary side)	Parameter		[Pr. PA17] setting	[Pr. PA18] setting	LM-F	LM-FP2B-06M-1SS0 (natural cooling)	00B2h	2201h	LM-FP2D-12M-1SS0 (natural cooling)	2401h	LM-FP2F-18M-1SS0 (natural cooling)	2601h	LM-FP4B-12M-1SS0 (natural cooling)	4201h	LM-FP4D-24M-1SS0 (natural cooling)	4401h	LM-FP4F-36M-1SS0 (natural cooling)	4601h	LM-FP4H-48M-1SS0 (natural cooling)	4801h	LM-FP5H-60M-1SS0 (natural cooling)	5801h	LM-FP2B-06M-1SS0 (liquid-cooling)	2202h	LM-FP2D-12M-1SS0 (liquid-cooling)	2402h	LM-FP2F-18M-1SS0 (liquid-cooling)	2602h	LM-FP4B-12M-1SS0 (liquid-cooling)	4202h	LM-FP4D-24M-1SS0 (liquid-cooling)	4402h	LM-FP4F-36M-1SS0 (liquid-cooling)	4602h	LM-FP4H-48M-1SS0 (liquid-cooling)	4802h	LM-FP5H-60M-1SS0 (liquid-cooling)	5802h	LM-K2	LM-K2P1A-01M-2SS1	00B8h	1101h	LM-K2P1C-03M-2SS1	1301h	LM-K2P2A-02M-1SS1	2101h	LM-K2P2C-07M-1SS1	2301h	LM-K2P2E-12M-1SS1	2501h	LM-K2P3C-14M-1SS1	3301h	LM-K2P3E-24M-1SS1	3501h			
					Linear servo motor series	Linear servo motor (primary side)	Parameter																																																						
			[Pr. PA17] setting	[Pr. PA18] setting																																																									
			LM-F	LM-FP2B-06M-1SS0 (natural cooling)	00B2h	2201h																																																							
				LM-FP2D-12M-1SS0 (natural cooling)		2401h																																																							
				LM-FP2F-18M-1SS0 (natural cooling)		2601h																																																							
				LM-FP4B-12M-1SS0 (natural cooling)		4201h																																																							
				LM-FP4D-24M-1SS0 (natural cooling)		4401h																																																							
				LM-FP4F-36M-1SS0 (natural cooling)		4601h																																																							
				LM-FP4H-48M-1SS0 (natural cooling)		4801h																																																							
				LM-FP5H-60M-1SS0 (natural cooling)		5801h																																																							
				LM-FP2B-06M-1SS0 (liquid-cooling)		2202h																																																							
				LM-FP2D-12M-1SS0 (liquid-cooling)		2402h																																																							
				LM-FP2F-18M-1SS0 (liquid-cooling)		2602h																																																							
				LM-FP4B-12M-1SS0 (liquid-cooling)		4202h																																																							
				LM-FP4D-24M-1SS0 (liquid-cooling)		4402h																																																							
				LM-FP4F-36M-1SS0 (liquid-cooling)		4602h																																																							
				LM-FP4H-48M-1SS0 (liquid-cooling)		4802h																																																							
				LM-FP5H-60M-1SS0 (liquid-cooling)		5802h																																																							
				LM-K2		LM-K2P1A-01M-2SS1	00B8h	1101h																																																					
						LM-K2P1C-03M-2SS1		1301h																																																					
			LM-K2P2A-02M-1SS1		2101h																																																								
			LM-K2P2C-07M-1SS1		2301h																																																								
			LM-K2P2E-12M-1SS1		2501h																																																								
LM-K2P3C-14M-1SS1	3301h																																																												
LM-K2P3E-24M-1SS1	3501h																																																												

7. PARAMETERS

No./ symbol/name	Setting digit	Function	Initial value [unit]	Control mode																																																																																																																																																																																																																															
				CP/BCD	CL	PS																																																																																																																																																																																																																													
PA18 *MTY Servo motor type setting		When using a linear servo motor, select any linear servo motor with [Pr. PA17] and [Pr. PA18]. Set this and [Pr. PA17] at a time. Refer to the table of [Pr. PA17] for settings. This parameter is not available with MR-J4-03A6-RJ servo amplifiers.	0000h	<input type="radio"/>	<input type="radio"/>	<input type="radio"/>																																																																																																																																																																																																																													
PA19 *BLK Parameter writing inhibit		Select a reference range and writing range of the parameter. To enable read/write the positioning control parameters ([Pr. PT__]), set [Pr. PA19] to "0 0 A B" in the positioning mode. Refer to table 7.4 for settings. Linear servo motor/DD motor setting parameters ([Pr. PL__]) cannot be used with MR-J4-03A6-RJ servo amplifiers.	00AAh	<input type="radio"/>	<input type="radio"/>	<input type="radio"/>																																																																																																																																																																																																																													
<p>Table 7.4 [Pr. PA19] setting value and reading/writing range</p> <table border="1"> <thead> <tr> <th>PA19</th> <th>Setting operation</th> <th>PA</th> <th>PB</th> <th>PC</th> <th>PD</th> <th>PE</th> <th>PF</th> <th>PL</th> <th>Po</th> <th>PT</th> </tr> </thead> <tbody> <tr> <td rowspan="2">Other than below</td> <td>Reading</td> <td><input type="radio"/></td> <td>/</td> <td>/</td> <td>/</td> <td>/</td> <td>/</td> <td>/</td> <td>/</td> <td>/</td> </tr> <tr> <td>Writing</td> <td><input type="radio"/></td> <td>/</td> <td>/</td> <td>/</td> <td>/</td> <td>/</td> <td>/</td> <td>/</td> <td>/</td> </tr> <tr> <td rowspan="2">000Ah</td> <td>Reading</td> <td>Only 19</td> <td>/</td> <td>/</td> <td>/</td> <td>/</td> <td>/</td> <td>/</td> <td>/</td> <td>/</td> </tr> <tr> <td>Writing</td> <td>Only 19</td> <td>/</td> <td>/</td> <td>/</td> <td>/</td> <td>/</td> <td>/</td> <td>/</td> <td>/</td> </tr> <tr> <td rowspan="2">000Bh</td> <td>Reading</td> <td><input type="radio"/></td> <td><input type="radio"/></td> <td><input type="radio"/></td> <td>/</td> <td>/</td> <td>/</td> <td>/</td> <td>/</td> <td>/</td> </tr> <tr> <td>Writing</td> <td><input type="radio"/></td> <td><input type="radio"/></td> <td><input type="radio"/></td> <td>/</td> <td>/</td> <td>/</td> <td>/</td> <td>/</td> <td>/</td> </tr> <tr> <td rowspan="2">000Ch</td> <td>Reading</td> <td><input type="radio"/></td> <td><input type="radio"/></td> <td><input type="radio"/></td> <td><input type="radio"/></td> <td>/</td> <td>/</td> <td>/</td> <td>/</td> <td>/</td> </tr> <tr> <td>Writing</td> <td><input type="radio"/></td> <td><input type="radio"/></td> <td><input type="radio"/></td> <td><input type="radio"/></td> <td>/</td> <td>/</td> <td>/</td> <td>/</td> <td>/</td> </tr> <tr> <td rowspan="2">00AAh (initial value)</td> <td>Reading</td> <td><input type="radio"/></td> <td><input type="radio"/></td> <td><input type="radio"/></td> <td><input type="radio"/></td> <td><input type="radio"/></td> <td><input type="radio"/></td> <td>/</td> <td>/</td> <td>/</td> </tr> <tr> <td>Writing</td> <td><input type="radio"/></td> <td><input type="radio"/></td> <td><input type="radio"/></td> <td><input type="radio"/></td> <td><input type="radio"/></td> <td><input type="radio"/></td> <td>/</td> <td>/</td> <td>/</td> </tr> <tr> <td rowspan="2">00ABh</td> <td>Reading</td> <td><input type="radio"/></td> <td><input type="radio"/></td> <td><input type="radio"/></td> <td><input type="radio"/></td> <td><input type="radio"/></td> <td><input type="radio"/></td> <td><input type="radio"/></td> <td><input type="radio"/></td> <td><input type="radio"/></td> </tr> <tr> <td>Writing</td> <td><input type="radio"/></td> <td><input type="radio"/></td> <td><input type="radio"/></td> <td><input type="radio"/></td> <td><input type="radio"/></td> <td><input type="radio"/></td> <td><input type="radio"/></td> <td><input type="radio"/></td> <td><input type="radio"/></td> </tr> <tr> <td rowspan="2">100Bh</td> <td>Reading</td> <td><input type="radio"/></td> <td>/</td> <td>/</td> <td>/</td> <td>/</td> <td>/</td> <td>/</td> <td>/</td> <td>/</td> </tr> <tr> <td>Writing</td> <td>Only 19</td> <td>/</td> <td>/</td> <td>/</td> <td>/</td> <td>/</td> <td>/</td> <td>/</td> <td>/</td> </tr> <tr> <td rowspan="2">100Ch</td> <td>Reading</td> <td><input type="radio"/></td> <td><input type="radio"/></td> <td><input type="radio"/></td> <td><input type="radio"/></td> <td>/</td> <td>/</td> <td>/</td> <td>/</td> <td>/</td> </tr> <tr> <td>Writing</td> <td>Only 19</td> <td>/</td> <td>/</td> <td>/</td> <td>/</td> <td>/</td> <td>/</td> <td>/</td> <td>/</td> </tr> <tr> <td rowspan="2">10AAh</td> <td>Reading</td> <td><input type="radio"/></td> <td><input type="radio"/></td> <td><input type="radio"/></td> <td><input type="radio"/></td> <td><input type="radio"/></td> <td><input type="radio"/></td> <td>/</td> <td>/</td> <td>/</td> </tr> <tr> <td>Writing</td> <td>Only 19</td> <td>/</td> <td>/</td> <td>/</td> <td>/</td> <td>/</td> <td>/</td> <td>/</td> <td>/</td> </tr> <tr> <td rowspan="2">10ABh</td> <td>Reading</td> <td><input type="radio"/></td> <td><input type="radio"/></td> <td><input type="radio"/></td> <td><input type="radio"/></td> <td><input type="radio"/></td> <td><input type="radio"/></td> <td><input type="radio"/></td> <td><input type="radio"/></td> <td><input type="radio"/></td> </tr> <tr> <td>Writing</td> <td>Only 19</td> <td>/</td> <td>/</td> <td>/</td> <td>/</td> <td>/</td> <td>/</td> <td>/</td> <td>/</td> </tr> </tbody> </table>							PA19	Setting operation	PA	PB	PC	PD	PE	PF	PL	Po	PT	Other than below	Reading	<input type="radio"/>	/	/	/	/	/	/	/	/	Writing	<input type="radio"/>	/	/	/	/	/	/	/	/	000Ah	Reading	Only 19	/	/	/	/	/	/	/	/	Writing	Only 19	/	/	/	/	/	/	/	/	000Bh	Reading	<input type="radio"/>	<input type="radio"/>	<input type="radio"/>	/	/	/	/	/	/	Writing	<input type="radio"/>	<input type="radio"/>	<input type="radio"/>	/	/	/	/	/	/	000Ch	Reading	<input type="radio"/>	<input type="radio"/>	<input type="radio"/>	<input type="radio"/>	/	/	/	/	/	Writing	<input type="radio"/>	<input type="radio"/>	<input type="radio"/>	<input type="radio"/>	/	/	/	/	/	00AAh (initial value)	Reading	<input type="radio"/>	<input type="radio"/>	<input type="radio"/>	<input type="radio"/>	<input type="radio"/>	<input type="radio"/>	/	/	/	Writing	<input type="radio"/>	<input type="radio"/>	<input type="radio"/>	<input type="radio"/>	<input type="radio"/>	<input type="radio"/>	/	/	/	00ABh	Reading	<input type="radio"/>	<input type="radio"/>	<input type="radio"/>	<input type="radio"/>	<input type="radio"/>	<input type="radio"/>	<input type="radio"/>	<input type="radio"/>	<input type="radio"/>	Writing	<input type="radio"/>	<input type="radio"/>	<input type="radio"/>	<input type="radio"/>	<input type="radio"/>	<input type="radio"/>	<input type="radio"/>	<input type="radio"/>	<input type="radio"/>	100Bh	Reading	<input type="radio"/>	/	/	/	/	/	/	/	/	Writing	Only 19	/	/	/	/	/	/	/	/	100Ch	Reading	<input type="radio"/>	<input type="radio"/>	<input type="radio"/>	<input type="radio"/>	/	/	/	/	/	Writing	Only 19	/	/	/	/	/	/	/	/	10AAh	Reading	<input type="radio"/>	<input type="radio"/>	<input type="radio"/>	<input type="radio"/>	<input type="radio"/>	<input type="radio"/>	/	/	/	Writing	Only 19	/	/	/	/	/	/	/	/	10ABh	Reading	<input type="radio"/>	<input type="radio"/>	<input type="radio"/>	<input type="radio"/>	<input type="radio"/>	<input type="radio"/>	<input type="radio"/>	<input type="radio"/>	<input type="radio"/>	Writing	Only 19	/	/	/	/	/	/	/	/
PA19	Setting operation	PA	PB	PC	PD	PE	PF	PL	Po	PT																																																																																																																																																																																																																									
Other than below	Reading	<input type="radio"/>	/	/	/	/	/	/	/	/																																																																																																																																																																																																																									
	Writing	<input type="radio"/>	/	/	/	/	/	/	/	/																																																																																																																																																																																																																									
000Ah	Reading	Only 19	/	/	/	/	/	/	/	/																																																																																																																																																																																																																									
	Writing	Only 19	/	/	/	/	/	/	/	/																																																																																																																																																																																																																									
000Bh	Reading	<input type="radio"/>	<input type="radio"/>	<input type="radio"/>	/	/	/	/	/	/																																																																																																																																																																																																																									
	Writing	<input type="radio"/>	<input type="radio"/>	<input type="radio"/>	/	/	/	/	/	/																																																																																																																																																																																																																									
000Ch	Reading	<input type="radio"/>	<input type="radio"/>	<input type="radio"/>	<input type="radio"/>	/	/	/	/	/																																																																																																																																																																																																																									
	Writing	<input type="radio"/>	<input type="radio"/>	<input type="radio"/>	<input type="radio"/>	/	/	/	/	/																																																																																																																																																																																																																									
00AAh (initial value)	Reading	<input type="radio"/>	<input type="radio"/>	<input type="radio"/>	<input type="radio"/>	<input type="radio"/>	<input type="radio"/>	/	/	/																																																																																																																																																																																																																									
	Writing	<input type="radio"/>	<input type="radio"/>	<input type="radio"/>	<input type="radio"/>	<input type="radio"/>	<input type="radio"/>	/	/	/																																																																																																																																																																																																																									
00ABh	Reading	<input type="radio"/>	<input type="radio"/>	<input type="radio"/>	<input type="radio"/>	<input type="radio"/>	<input type="radio"/>	<input type="radio"/>	<input type="radio"/>	<input type="radio"/>																																																																																																																																																																																																																									
	Writing	<input type="radio"/>	<input type="radio"/>	<input type="radio"/>	<input type="radio"/>	<input type="radio"/>	<input type="radio"/>	<input type="radio"/>	<input type="radio"/>	<input type="radio"/>																																																																																																																																																																																																																									
100Bh	Reading	<input type="radio"/>	/	/	/	/	/	/	/	/																																																																																																																																																																																																																									
	Writing	Only 19	/	/	/	/	/	/	/	/																																																																																																																																																																																																																									
100Ch	Reading	<input type="radio"/>	<input type="radio"/>	<input type="radio"/>	<input type="radio"/>	/	/	/	/	/																																																																																																																																																																																																																									
	Writing	Only 19	/	/	/	/	/	/	/	/																																																																																																																																																																																																																									
10AAh	Reading	<input type="radio"/>	<input type="radio"/>	<input type="radio"/>	<input type="radio"/>	<input type="radio"/>	<input type="radio"/>	/	/	/																																																																																																																																																																																																																									
	Writing	Only 19	/	/	/	/	/	/	/	/																																																																																																																																																																																																																									
10ABh	Reading	<input type="radio"/>	<input type="radio"/>	<input type="radio"/>	<input type="radio"/>	<input type="radio"/>	<input type="radio"/>	<input type="radio"/>	<input type="radio"/>	<input type="radio"/>																																																																																																																																																																																																																									
	Writing	Only 19	/	/	/	/	/	/	/	/																																																																																																																																																																																																																									

7. PARAMETERS

No./ symbol/name	Setting digit	Function	Initial value [unit]	Control mode		
				CP/BCD	OL	PS
PA20 *TDS Tough drive setting	Alarms may not be avoided with the tough drive function depending on the situations of the power supply and load fluctuation. You can assign MTTR (During tough drive) to pins CN1-13, CN1-14, CN1-22 to CN1-25, and CN1-49 with [Pr. PD23] to [Pr. PD26], [Pr. PD28], and [Pr. PD47]. For MR-J4-03A6-RJ servo amplifiers, MTTR (During tough drive) cannot be assigned.					
	___x	For manufacturer setting	0h			
	__x_	Vibration tough drive selection 0: Disabled 1: Enabled Selecting "1" enables to suppress vibrations by automatically changing setting values of [Pr. PB13 Machine resonance suppression filter 1] and [Pr. PB15 Machine resonance suppression filter 2] in case that the vibration exceed the value of the oscillation level set in [Pr. PF23]. To output the oscillation detection alarm as a warning, set [Pr. PF24 Vibration tough drive function selection]. For details, refer to section 7.3 of "MR-J4-_A_(-RJ) Servo Amplifier Instruction Manual".	0h	○	○	○
	_x__	SEMI-F47 function selection 0: Disabled 1: Enabled Selecting "1" enables to avoid triggering [AL. 10 Undervoltage] using the electrical energy charged in the capacitor in case that an instantaneous power failure occurs during operation. In [Pr. PF25 SEMI-F47 function - Instantaneous power failure detection time], set the time until the occurrence of [AL. 10.1 Voltage drop in the control circuit power]. For MR-J4-03A6-RJ servo amplifiers, this digit cannot be used other than the initial value.	0h	○	○	○
	x___	For manufacturer setting	0h			
PA21 *AOP3 Function selection A-3	___x	One-touch tuning function selection 0: Disabled 1: Enabled When the digit is "0", the one-touch tuning is not available.	1h	○	○	○
	__x_	For manufacturer setting	0h			
	_x__	For manufacturer setting	0h			
	x___	Electronic gear selection When this digit is changed, the home position will be changed. Execute the home position return again. 0: Electronic gear ([Pr. PA06] and [Pr. PA07]) 1: Not used for positioning mode. Setting this will trigger [AL. 37 Parameter error]. 2: J3 electronic gear setting value compatibility mode (Electronic gear ([Pr. PA06] and [Pr. PA07] × 16)) The electronic gear setting value can be used set with MR-J3. 3: J2S electronic gear setting value compatibility mode (Electronic gear ([Pr. PA06] and [Pr. PA07] × 32)) The electronic gear setting value can be used set with MR-J2S. For MR-J4-03A6-RJ servo amplifiers, "2" and "3" cannot be selected for this digit.	0h	○	○	
PA22 *PCS Position control composition selection	___x	For manufacturer setting	0h			
	__x_	Super trace control selection 0: Disabled 2: Enabled This parameter setting is used with servo amplifier with software version B4 or later.	0h	○	○	○
	_x__	For manufacturer setting	0h			
	x___	For manufacturer setting	0h			

7. PARAMETERS

No./ symbol/name	Setting digit	Function	Initial value [unit]	Control mode		
				CP/BCD	OL	PS
PA23 DRAT Drive recorder arbitrary alarm trigger setting	__ x x	Alarm detail No. setting Set the digits when you execute the trigger with arbitrary alarm detail No. for the drive recorder function. When these digits are "0 0", only the arbitrary alarm No. setting will be enabled.	00h	<input type="radio"/>	<input type="radio"/>	<input type="radio"/>
	x x __	Alarm No. setting Set the digits when you execute the trigger with arbitrary alarm No. for the drive recorder function. When "0 0" are set, arbitrary alarm trigger of the drive recorder will be disabled.	00h	<input type="radio"/>	<input type="radio"/>	<input type="radio"/>
	Setting example: To activate the drive recorder when [AL. 50 Overload 1] occurs, set "5 0 0 0". To activate the drive recorder when [AL. 50.3 Thermal overload error 4 during operation] occurs, set "5 0 0 3".					
PA24 AOP4 Function selection A-4	___ x	Vibration suppression mode selection 0: Standard mode 1: 3 inertia mode 2: Low response mode When you select the standard mode or low response mode, "Vibration suppression control 2" is not available. When you select the 3 inertia mode, the feed forward gain is not available.	0h	<input type="radio"/>	<input type="radio"/>	<input type="radio"/>
	__ x _	For manufacturer setting	0h	<input type="checkbox"/>	<input type="checkbox"/>	<input type="checkbox"/>
	_ x _ _		0h	<input type="checkbox"/>	<input type="checkbox"/>	<input type="checkbox"/>
	x _ _ _		0h	<input type="checkbox"/>	<input type="checkbox"/>	<input type="checkbox"/>
PA25 OTHOV One-touch tuning - Overshoot permissible level		Set a permissible value of overshoot amount for one-touch tuning as a percentage of the in-position range. However, setting "0" will be 50%. Setting range: 0 to 100	0 [%]	<input type="radio"/>	<input type="radio"/>	<input type="radio"/>
PA26 *AOP5 Function selection A-5	___ x	Torque limit function selection at instantaneous power failure (instantaneous power failure tough drive selection) 0: Disabled 1: Enabled When an instantaneous power failure occurs during operation, you can save electric energy charged in the capacitor in the servo amplifier by limiting torque at acceleration. You can also delay the time until [AL. 10.2 Voltage drop in the main circuit power] occurs with instantaneous power failure tough drive function. Doing this will enable you to set a longer time in [Pr. PF25 SEMI-F47 function - Instantaneous power failure detection time]. The torque limit function at instantaneous power failure is enabled when "SEMI-F47 function selection" in [Pr. PA20] is "Enabled (_ 1 _)". For MR-J4-03A6-RJ servo amplifiers, this digit cannot be used other than the initial value.	0h	<input type="radio"/>	<input type="radio"/>	<input type="radio"/>
	__ x _	For manufacturer setting	0h	<input type="checkbox"/>	<input type="checkbox"/>	<input type="checkbox"/>
	_ x _ _		0h	<input type="checkbox"/>	<input type="checkbox"/>	<input type="checkbox"/>
	x _ _ _		0h	<input type="checkbox"/>	<input type="checkbox"/>	<input type="checkbox"/>

7. PARAMETERS

7.2.2 Gain/filter setting parameters ([Pr. PB_ _])

No./ symbol/name	Setting digit	Function	Initial value [unit]	Control mode		
				CP/BCD	OL	P.S
PB01 FILT Adaptive tuning mode (adaptive filter II)	__ _ x	Filter tuning mode selection Set the adaptive tuning. Select the adjustment mode of the machine resonance suppression filter 1. For details, refer to section 7.1.2 of "MR-J4- _A_(-RJ) Servo Amplifier Instruction Manual". 0: Disabled 1: Automatic setting 2: Manual setting	0h	○	○	○
	__ x _	For manufacturer setting	0h	△	△	△
	_ x _ _		0h	△	△	△
	x _ _ _	Tuning accuracy selection 0: Standard 1: High accuracy The frequency is estimated more accurately in the high accuracy mode compared to the standard mode. However, the tuning sound may be larger in the high accuracy mode. For details, refer to section 7.1.2 of "MR-J4- _A_(-RJ) Servo Amplifier Instruction Manual". This digit is available with servo amplifier with software version C5 or later.	0h	○	○	○
PB02 VRFT Vibration suppression control tuning mode (advanced vibration suppression control II)	__ _ x	Vibration suppression control 1 tuning mode selection Select the tuning mode of the vibration suppression control 1. For details, refer to section 7.1.5 of "MR-J4- _A_(-RJ) Servo Amplifier Instruction Manual". 0: Disabled 1: Automatic setting 2: Manual setting	0h	○	○	○
	__ x _	Vibration suppression control 2 tuning mode selection Select the tuning mode of the vibration suppression control 2. To enable the digit, select "3 inertia mode (_ _ _ 1)" of "Vibration suppression mode selection" in [Pr. PA24]. For details, refer to section 7.1.5 of "MR-J4- _A_(-RJ) Servo Amplifier Instruction Manual". 0: Disabled 1: Automatic setting 2: Manual setting	0h	○	○	○
	_ x _ _	For manufacturer setting	0h	△	△	△
	x _ _ _		0h	△	△	△

7. PARAMETERS

No./ symbol/name	Setting digit	Function	Initial value [unit]	Control mode											
				CP/BCD	CL	PS									
PB03 PST Position command acceleration/d eceleration time constant (position smoothing)		<p>This is used to set the constant of a primary delay to the position command. You can select a control method from "Primary delay" or "Linear acceleration/deceleration" in [Pr. PB25 Function selection B-1]. The setting range of "Linear acceleration/deceleration" is 0 ms to 10 ms. Setting of longer than 10 ms will be recognized as 10 ms.</p> <p>(Example) When a command is given from a synchronizing encoder, synchronous operation will start smoothly even if it starts during line operation.</p> <p>Setting range: 0 to 65535</p>	0 [ms]	<input type="radio"/>	<input type="radio"/>	<input type="radio"/>									
PB04 FFC Feed forward gain		<p>Set the feed forward gain. When the setting is 100%, the droop pulses during operation at constant speed are nearly zero. However, sudden acceleration/deceleration will increase the overshoot. As a guideline, when the feed forward gain setting is 100%, set 1 s or more as the acceleration time constant up to the rated speed.</p> <p>Setting range: 0 to 100</p>	0 [%]	<input type="radio"/>	<input type="radio"/>	<input type="radio"/>									
PB06 GD2 Load to motor inertia ratio/load to motor mass ratio		<p>This is used to set the load to motor inertia ratio or load to motor mass ratio. Setting a value considerably different from the actual load moment of inertia may cause an unexpected operation such as an overshoot. The setting of the parameter will be the automatic setting or manual setting depending on the [Pr. PA08] setting. Refer to the following table for details. When the parameter is automatic setting, the value will vary between 0.00 and 100.00.</p> <p>Setting range: 0.00 to 300.00</p> <table border="1" style="margin-left: auto; margin-right: auto;"> <thead> <tr> <th>Pr. PA08</th> <th>This parameter</th> </tr> </thead> <tbody> <tr> <td>___ 0 (2 gain adjustment mode 1 (interpolation mode))</td> <td rowspan="2">Automatic setting</td> </tr> <tr> <td>___ 1 (Auto tuning mode 1)</td> </tr> <tr> <td>___ 2 (Auto tuning mode 2)</td> <td rowspan="3">Manual setting</td> </tr> <tr> <td>___ 3 (Manual mode)</td> </tr> <tr> <td>___ 4 (2 gain adjustment mode 2)</td> </tr> </tbody> </table>	Pr. PA08	This parameter	___ 0 (2 gain adjustment mode 1 (interpolation mode))	Automatic setting	___ 1 (Auto tuning mode 1)	___ 2 (Auto tuning mode 2)	Manual setting	___ 3 (Manual mode)	___ 4 (2 gain adjustment mode 2)	7.00 [Multiplier]	<input type="radio"/>	<input type="radio"/>	<input type="radio"/>
Pr. PA08	This parameter														
___ 0 (2 gain adjustment mode 1 (interpolation mode))	Automatic setting														
___ 1 (Auto tuning mode 1)															
___ 2 (Auto tuning mode 2)	Manual setting														
___ 3 (Manual mode)															
___ 4 (2 gain adjustment mode 2)															

7. PARAMETERS

No./ symbol/name	Setting digit	Function	Initial value [unit]	Control mode						
				CP/BCD	OL	PS				
PB07 PG1 Model loop gain		<p>Set the response gain up to the target position.</p> <p>Increasing the setting value will also increase the response level to the position command but will be liable to generate vibration and noise.</p> <p>The setting of the parameter will be the automatic setting or manual setting depending on the [Pr. PA08] setting. Refer to the following table for details.</p> <p>Setting range: 1.0 to 2000.0</p>	15.0 [rad/s]	<input type="radio"/>	<input type="radio"/>	<input type="radio"/>				
		<table border="1"> <thead> <tr> <th>Pr. PA08</th> <th>This parameter</th> </tr> </thead> <tbody> <tr> <td>___ 0 (2 gain adjustment mode 1 (interpolation mode))</td> <td>Manual setting</td> </tr> <tr> <td>___ 1 (Auto tuning mode 1)</td> <td rowspan="2">Automatic setting</td> </tr> <tr> <td>___ 2 (Auto tuning mode 2)</td> </tr> <tr> <td>___ 3 (Manual mode)</td> <td rowspan="2">Manual setting</td> </tr> <tr> <td>___ 4 (2 gain adjustment mode 2)</td> </tr> </tbody> </table>					Pr. PA08	This parameter	___ 0 (2 gain adjustment mode 1 (interpolation mode))	Manual setting
Pr. PA08	This parameter									
___ 0 (2 gain adjustment mode 1 (interpolation mode))	Manual setting									
___ 1 (Auto tuning mode 1)	Automatic setting									
___ 2 (Auto tuning mode 2)										
___ 3 (Manual mode)	Manual setting									
___ 4 (2 gain adjustment mode 2)										
PB08 PG2 Position loop gain		<p>This is used to set the gain of the position loop.</p> <p>Set this parameter to increase the position response to level load disturbance. Increasing the setting value will also increase the response level to the load disturbance but will be liable to generate vibration and noise.</p> <p>The setting of the parameter will be the automatic setting or manual setting depending on the [Pr. PA08] setting. Refer to the following table for details.</p> <p>Setting range: 1.0 to 2000.0</p>	37.0 [rad/s]	<input type="radio"/>	<input type="radio"/>	<input type="radio"/>				
		<table border="1"> <thead> <tr> <th>Pr. PA08</th> <th>This parameter</th> </tr> </thead> <tbody> <tr> <td>___ 0 (2 gain adjustment mode 1 (interpolation mode))</td> <td rowspan="3">Automatic setting</td> </tr> <tr> <td>___ 1 (Auto tuning mode 1)</td> </tr> <tr> <td>___ 2 (Auto tuning mode 2)</td> </tr> <tr> <td>___ 3 (Manual mode)</td> <td>Manual setting</td> </tr> <tr> <td>___ 4 (2 gain adjustment mode 2)</td> <td>Automatic setting</td> </tr> </tbody> </table>					Pr. PA08	This parameter	___ 0 (2 gain adjustment mode 1 (interpolation mode))	Automatic setting
Pr. PA08	This parameter									
___ 0 (2 gain adjustment mode 1 (interpolation mode))	Automatic setting									
___ 1 (Auto tuning mode 1)										
___ 2 (Auto tuning mode 2)										
___ 3 (Manual mode)	Manual setting									
___ 4 (2 gain adjustment mode 2)	Automatic setting									
PB09 VG2 Speed loop gain		<p>This is used to set the gain of the speed loop.</p> <p>Set this parameter when vibration occurs on machines of low rigidity or large backlash. Increasing the setting value will also increase the response level but will be liable to generate vibration and noise.</p> <p>The setting of the parameter will be the automatic setting or manual setting depending on the [Pr. PA08] setting. Refer to the table of [Pr. PB08] for details.</p> <p>Setting range: 20 to 65535</p>	823 [rad/s]	<input type="radio"/>	<input type="radio"/>	<input type="radio"/>				
PB10 VIC Speed integral compensation		<p>Set the integral time constant of the speed loop.</p> <p>Decreasing the setting value will increase the response level but will be liable to generate vibration and noise.</p> <p>The setting of the parameter will be the automatic setting or manual setting depending on the [Pr. PA08] setting. Refer to the table of [Pr. PB08] for details.</p> <p>Setting range: 0.1 to 1000.0</p>	33.7 [ms]	<input type="radio"/>	<input type="radio"/>	<input type="radio"/>				
PB11 VDC Speed differential compensation		<p>Set the differential compensation.</p> <p>To enable the setting value, turn on PC (proportional control).</p> <p>Setting range: 0 to 1000</p>	980	<input type="radio"/>	<input type="radio"/>	<input type="radio"/>				

7. PARAMETERS

No./ symbol/name	Setting digit	Function	Initial value [unit]	Control mode		
				CP/BCD	OL	PS
PB12 OVA Overshoot amount compensation		Set a percentage of viscous friction torque against the servo motor rated value or thrust against the linear servo motor rated value. When the response level is low or when the torque/thrust is limited, the efficiency of the parameter may be lower. Setting range: 0 to 100	0 [%]	<input type="radio"/>	<input type="radio"/>	<input type="radio"/>
PB13 NH1 Machine resonance suppression filter 1		Machine resonance suppression filter 1 Set the notch frequency of the machine resonance suppression filter 1. When "Filter tuning mode selection" is set to "Automatic setting (___ 1)" in [Pr. PB01], this parameter will be adjusted automatically by adaptive tuning. When "Filter tuning mode selection" is set to "Manual setting (___ 2)" in [Pr. PB01], the setting value will be enabled. Setting range: 10 to 4500	4500 [Hz]	<input type="radio"/>	<input type="radio"/>	<input type="radio"/>
PB14 NHQ1 Notch shape selection 1		Set forms of the machine resonance suppression filter 1. When "Filter tuning mode selection" is set to "Automatic setting (___ 1)" in [Pr. PB01], this parameter will be adjusted automatically by adaptive tuning. When "Filter tuning mode selection" is set to "Manual setting (___ 2)" in [Pr. PB01], the setting value will be enabled.				
	___ x	For manufacturer setting	0h	<input type="radio"/>	<input type="radio"/>	<input type="radio"/>
	__ x _	Notch depth selection 0: -40 dB 1: -14 dB 2: -8 dB 3: -4 dB	0h	<input type="radio"/>	<input type="radio"/>	<input type="radio"/>
	_ x _ _	Notch width selection 0: $\alpha = 2$ 1: $\alpha = 3$ 2: $\alpha = 4$ 3: $\alpha = 5$	0h	<input type="radio"/>	<input type="radio"/>	<input type="radio"/>
	x _ _ _	For manufacturer setting	0h	<input type="radio"/>	<input type="radio"/>	<input type="radio"/>
PB15 NH2 Machine resonance suppression filter 2		Set the notch frequency of the machine resonance suppression filter 2. To enable the setting value, select "Enabled (___ 1)" of "Machine resonance suppression filter 2 selection" in [Pr. PB16]. Setting range: 10 to 4500	4500 [Hz]	<input type="radio"/>	<input type="radio"/>	<input type="radio"/>
PB16 NHQ2 Notch shape selection 2		Set forms of the machine resonance suppression filter 2.				
	___ x	Machine resonance suppression filter 2 selection 0: Disabled 1: Enabled	0h	<input type="radio"/>	<input type="radio"/>	<input type="radio"/>
	__ x _	Notch depth selection 0: -40 dB 1: -14 dB 2: -8 dB 3: -4 dB	0h	<input type="radio"/>	<input type="radio"/>	<input type="radio"/>
	_ x _ _	Notch width selection 0: $\alpha = 2$ 1: $\alpha = 3$ 2: $\alpha = 4$ 3: $\alpha = 5$	0h	<input type="radio"/>	<input type="radio"/>	<input type="radio"/>
	x _ _ _	For manufacturer setting	0h	<input type="radio"/>	<input type="radio"/>	<input type="radio"/>

7. PARAMETERS

No./ symbol/name	Setting digit	Function	Initial value [unit]	Control mode																																																																						
				CP/BCD	OL	PS																																																																				
PB17 NHF Shaft resonance suppression filter		Set the shaft resonance suppression filter. This is used to suppress a low-frequency machine vibration. When "Shaft resonance suppression filter selection" is set to "Automatic setting (_ _ 0)" in [Pr. PB23], the value will be calculated automatically from the servo motor you use and load to motor inertia ratio. Set manually for "Manual setting (_ _ 1)". When "Shaft resonance suppression filter selection" is set to "Disabled (_ _ 2)" in [Pr. PB23], the setting value of this parameter will be disabled. When "Machine resonance suppression filter 4 selection" is set to "Enabled (_ _ 1)" in [Pr. PB49], the shaft resonance suppression filter is not available.																																																																								
	_ _ x x	Shaft resonance suppression filter setting frequency selection Refer to table 7.5 for settings. Set the value closest to the frequency you need.	00h	<input type="radio"/>	<input type="radio"/>	<input type="radio"/>																																																																				
	_ x _ _	Notch depth selection 0: -40 dB 1: -14 dB 2: -8 dB 3: -4 dB	0h	<input type="radio"/>	<input type="radio"/>	<input type="radio"/>																																																																				
	x _ _ _	For manufacturer setting	0h	<input type="checkbox"/>	<input type="checkbox"/>	<input type="checkbox"/>																																																																				
<p>Table 7.5 Shaft resonance suppression filter setting frequency selection</p> <table border="1" style="width: 100%; border-collapse: collapse;"> <thead> <tr> <th>Setting value</th> <th>Frequency [Hz]</th> <th>Setting value</th> <th>Frequency [Hz]</th> </tr> </thead> <tbody> <tr><td>_ _ 0 0</td><td>Disabled</td><td>_ _ 1 0</td><td>562</td></tr> <tr><td>_ _ 0 1</td><td>Disabled</td><td>_ _ 1 1</td><td>529</td></tr> <tr><td>_ _ 0 2</td><td>4500</td><td>_ _ 1 2</td><td>500</td></tr> <tr><td>_ _ 0 3</td><td>3000</td><td>_ _ 1 3</td><td>473</td></tr> <tr><td>_ _ 0 4</td><td>2250</td><td>_ _ 1 4</td><td>450</td></tr> <tr><td>_ _ 0 5</td><td>1800</td><td>_ _ 1 5</td><td>428</td></tr> <tr><td>_ _ 0 6</td><td>1500</td><td>_ _ 1 6</td><td>409</td></tr> <tr><td>_ _ 0 7</td><td>1285</td><td>_ _ 1 7</td><td>391</td></tr> <tr><td>_ _ 0 8</td><td>1125</td><td>_ _ 1 8</td><td>375</td></tr> <tr><td>_ _ 0 9</td><td>1000</td><td>_ _ 1 9</td><td>360</td></tr> <tr><td>_ _ 0 A</td><td>900</td><td>_ _ 1 A</td><td>346</td></tr> <tr><td>_ _ 0 B</td><td>818</td><td>_ _ 1 B</td><td>333</td></tr> <tr><td>_ _ 0 C</td><td>750</td><td>_ _ 1 C</td><td>321</td></tr> <tr><td>_ _ 0 D</td><td>692</td><td>_ _ 1 D</td><td>310</td></tr> <tr><td>_ _ 0 E</td><td>642</td><td>_ _ 1 E</td><td>300</td></tr> <tr><td>_ _ 0 F</td><td>600</td><td>_ _ 1 F</td><td>290</td></tr> </tbody> </table>							Setting value	Frequency [Hz]	Setting value	Frequency [Hz]	_ _ 0 0	Disabled	_ _ 1 0	562	_ _ 0 1	Disabled	_ _ 1 1	529	_ _ 0 2	4500	_ _ 1 2	500	_ _ 0 3	3000	_ _ 1 3	473	_ _ 0 4	2250	_ _ 1 4	450	_ _ 0 5	1800	_ _ 1 5	428	_ _ 0 6	1500	_ _ 1 6	409	_ _ 0 7	1285	_ _ 1 7	391	_ _ 0 8	1125	_ _ 1 8	375	_ _ 0 9	1000	_ _ 1 9	360	_ _ 0 A	900	_ _ 1 A	346	_ _ 0 B	818	_ _ 1 B	333	_ _ 0 C	750	_ _ 1 C	321	_ _ 0 D	692	_ _ 1 D	310	_ _ 0 E	642	_ _ 1 E	300	_ _ 0 F	600	_ _ 1 F	290
Setting value	Frequency [Hz]	Setting value	Frequency [Hz]																																																																							
_ _ 0 0	Disabled	_ _ 1 0	562																																																																							
_ _ 0 1	Disabled	_ _ 1 1	529																																																																							
_ _ 0 2	4500	_ _ 1 2	500																																																																							
_ _ 0 3	3000	_ _ 1 3	473																																																																							
_ _ 0 4	2250	_ _ 1 4	450																																																																							
_ _ 0 5	1800	_ _ 1 5	428																																																																							
_ _ 0 6	1500	_ _ 1 6	409																																																																							
_ _ 0 7	1285	_ _ 1 7	391																																																																							
_ _ 0 8	1125	_ _ 1 8	375																																																																							
_ _ 0 9	1000	_ _ 1 9	360																																																																							
_ _ 0 A	900	_ _ 1 A	346																																																																							
_ _ 0 B	818	_ _ 1 B	333																																																																							
_ _ 0 C	750	_ _ 1 C	321																																																																							
_ _ 0 D	692	_ _ 1 D	310																																																																							
_ _ 0 E	642	_ _ 1 E	300																																																																							
_ _ 0 F	600	_ _ 1 F	290																																																																							
PB18 LPF Low-pass filter setting		Set the low-pass filter. The following shows a relation of a required parameter to this parameter. Setting range: 100 to 18000	3141 [rad/s]	<input type="radio"/>	<input type="radio"/>	<input type="radio"/>																																																																				
		<table border="1" style="width: 100%; border-collapse: collapse;"> <thead> <tr> <th>[Pr. PB23]</th> <th>[Pr. PB18]</th> </tr> </thead> <tbody> <tr> <td>_ _ 0 _ (Initial value)</td> <td>Automatic setting</td> </tr> <tr> <td>_ _ 1 _</td> <td>Setting value enabled</td> </tr> <tr> <td>_ _ 2 _</td> <td>Setting value disabled</td> </tr> </tbody> </table>	[Pr. PB23]	[Pr. PB18]	_ _ 0 _ (Initial value)	Automatic setting	_ _ 1 _	Setting value enabled	_ _ 2 _	Setting value disabled																																																																
[Pr. PB23]	[Pr. PB18]																																																																									
_ _ 0 _ (Initial value)	Automatic setting																																																																									
_ _ 1 _	Setting value enabled																																																																									
_ _ 2 _	Setting value disabled																																																																									

7. PARAMETERS

No./ symbol/name	Setting digit	Function	Initial value [unit]	Control mode		
				CP/BCD	OL	PS
PB19 VRF11 Vibration suppression control 1 - Vibration frequency		Set the vibration frequency for vibration suppression control 1 to suppress low-frequency machine vibration. When "Vibration suppression control 1 tuning mode selection" is set to "Automatic setting (_ _ _ 1)" in [Pr. PB02], this parameter will be set automatically. When "Manual setting (_ _ _ 2)" is selected, the setting written to the parameter is used. For details, refer to section 7.1.5 of "MR-J4-_A_(-RJ) Servo Amplifier Instruction Manual". Setting range: 0.1 to 300.0	100.0 [Hz]	○	○	○
PB20 VRF12 Vibration suppression control 1 - Resonance frequency		Set the resonance frequency for vibration suppression control 1 to suppress low-frequency machine vibration. When "Vibration suppression control 1 tuning mode selection" is set to "Automatic setting (_ _ _ 1)" in [Pr. PB02], this parameter will be set automatically. When "Manual setting (_ _ _ 2)" is selected, the setting written to the parameter is used. For details, refer to section 7.1.5 of "MR-J4-_A_(-RJ) Servo Amplifier Instruction Manual". Setting range: 0.1 to 300.0	100.0 [Hz]	○	○	○
PB21 VRF13 Vibration suppression control 1 - Vibration frequency damping		Set a damping of the vibration frequency for vibration suppression control 1 to suppress low-frequency machine vibration. When "Vibration suppression control 1 tuning mode selection" is set to "Automatic setting (_ _ _ 1)" in [Pr. PB02], this parameter will be set automatically. When "Manual setting (_ _ _ 2)" is selected, the setting written to the parameter is used. For details, refer to section 7.1.5 of "MR-J4-_A_(-RJ) Servo Amplifier Instruction Manual". Setting range: 0.00 to 0.30	0.00	○	○	○
PB22 VRF14 Vibration suppression control 1 - Resonance frequency damping		Set a damping of the resonance frequency for vibration suppression control 1 to suppress low-frequency machine vibration. When "Vibration suppression control 1 tuning mode selection" is set to "Automatic setting (_ _ _ 1)" in [Pr. PB02], this parameter will be set automatically. When "Manual setting (_ _ _ 2)" is selected, the setting written to the parameter is used. For details, refer to section 7.1.5 of "MR-J4-_A_(-RJ) Servo Amplifier Instruction Manual". Setting range: 0.00 to 0.30	0.00	○	○	○
PB23 VFBF Low-pass filter selection	_ _ _ x	Shaft resonance suppression filter selection Select the shaft resonance suppression filter. 0: Automatic setting 1: Manual setting 2: Disabled When you select "Enabled (_ _ _ 1)" of "Machine resonance suppression filter 4 selection" in [Pr. PB49], the shaft resonance suppression filter is not available.	0h	○	○	○
	_ _ x _	Low-pass filter selection Select the low-pass filter. 0: Automatic setting 1: Manual setting 2: Disabled	0h	○	○	○
	_ x _ _	For manufacturer setting	0h			
	x _ _ _		0h			
PB24 *MVS Slight vibration suppression control	_ _ _ x	Slight vibration suppression control selection Select the slight vibration suppression control. 0: Disabled 1: Enabled To enable the slight vibration suppression control, select "Manual mode (_ _ _ 3)" of "Gain adjustment mode selection" in [Pr. PA08].	0h	○	○	○
	_ _ x _	For manufacturer setting	0h			
	_ x _ _		0h			
	x _ _ _		0h			

7. PARAMETERS

No./ symbol/name	Setting digit	Function	Initial value [unit]	Control mode		
				CP/BCD	CL	PS
PB25 *BOP1 Function selection B-1	___x	For manufacturer setting	0h	<input type="checkbox"/>	<input type="checkbox"/>	<input type="checkbox"/>
	__x_	Position acceleration/deceleration filter type selection Select the position acceleration/deceleration filter type. 0: Primary delay 1: Linear acceleration/deceleration	0h	<input type="checkbox"/>	<input type="checkbox"/>	<input type="checkbox"/>
	_x__	For manufacturer setting	0h	<input type="checkbox"/>	<input type="checkbox"/>	<input type="checkbox"/>
	x___	For manufacturer setting	0h	<input type="checkbox"/>	<input type="checkbox"/>	<input type="checkbox"/>
PB26 *CDP Gain switching function	Select the gain switching condition. Set conditions to enable the gain switching values set in [Pr. PB29] to [Pr. PB36] and [Pr. PB56] to [Pr. PB60].					
	___x	Gain switching selection 0: Disabled 1: Input device (gain switching (CDP)) 2: Command frequency (Note) 3: Droop pulses 4: Servo motor speed/linear servo motor speed Note. This will be a frequency of the servo motor side (load side for the fully closed loop control) command pulse unit.	0h	<input type="checkbox"/>	<input type="checkbox"/>	<input type="checkbox"/>
	__x_	Gain switching condition selection 0: Gain after switching is enabled with gain switching condition or more 1: Gain after switching is enabled with gain switching condition or less	0h	<input type="checkbox"/>	<input type="checkbox"/>	<input type="checkbox"/>
	_x__	For manufacturer setting	0h	<input type="checkbox"/>	<input type="checkbox"/>	<input type="checkbox"/>
PB27 CDL Gain switching condition	x___	This is used to set the value of gain switching (command frequency, droop pulses, and servo motor speed/linear servo motor speed) selected in [Pr. PB26]. The set value unit differs depending on the switching condition item. (Refer to "MR-J4-_A_(-RJ) Servo Amplifier Instruction Manual" section 7.2.3.) The unit "r/min" will be "mm/s" for linear servo motors. Setting range: 0 to 9999	10	<input type="checkbox"/>	<input type="checkbox"/>	<input type="checkbox"/>
			[kpulse/s]/ [pulse]/ [r/min]			
PB28 CDT Gain switching time constant		Set the time constant at which the gains will change in response to the conditions set in [Pr. PB26] and [Pr. PB27]. Setting range: 0 to 100	1 [ms]	<input type="checkbox"/>	<input type="checkbox"/>	<input type="checkbox"/>
PB29 GD2B Load to motor inertia ratio/load to motor mass ratio after gain switching		Set the load to motor inertia ratio/load to motor mass ratio for when gain switching is enabled. This parameter is enabled only when you select "Manual mode (___3)" of "Gain adjustment mode selection" in [Pr. PA08]. Setting range: 0.00 to 300.00	7.00 [Multiplier]	<input type="checkbox"/>	<input type="checkbox"/>	<input type="checkbox"/>
PB30 PG2B Position loop gain after gain switching		Set the position loop gain for when the gain switching is enabled. When you set a value less than 1.0 rad/s, the value will be the same as [Pr. PB08]. This parameter is enabled only when you select "Manual mode (___3)" of "Gain adjustment mode selection" in [Pr. PA08]. Setting range: 0.0 to 2000.0	0.0 [rad/s]	<input type="checkbox"/>	<input type="checkbox"/>	<input type="checkbox"/>
PB31 VG2B Speed loop gain after gain switching		Set the speed loop gain for when the gain switching is enabled. When you set a value less than 20 rad/s, the value will be the same as [Pr. PB09]. This parameter is enabled only when you select "Manual mode (___3)" of "Gain adjustment mode selection" in [Pr. PA08]. Setting range: 0 to 65535	0 [rad/s]	<input type="checkbox"/>	<input type="checkbox"/>	<input type="checkbox"/>

7. PARAMETERS

No./ symbol/name	Setting digit	Function	Initial value [unit]	Control mode		
				CP/BCD	CL	PS
PB32 VICB Speed integral compensation after gain switching		Set the speed integral compensation for when the gain switching is enabled. When you set a value less than 0.1 ms, the value will be the same as [Pr. PB10]. This parameter is enabled only when you select "Manual mode (_ _ _ 3)" of "Gain adjustment mode selection" in [Pr. PA08]. Setting range: 0.0 to 5000.0	0.0 [ms]	<input type="radio"/>	<input type="radio"/>	<input type="radio"/>
PB33 VRF1B Vibration suppression control 1 - Vibration frequency after gain switching		Set the vibration frequency for vibration suppression control 1 for when the gain switching is enabled. When you set a value less than 0.1 Hz, the value will be the same as [Pr. PB19]. This parameter will be enabled only when the following conditions are fulfilled. <ul style="list-style-type: none"> • "Gain adjustment mode selection" in [Pr. PA08] is "Manual mode (_ _ _ 3)". • "Vibration suppression control 1 tuning mode selection" in [Pr. PB02] is "Manual setting (_ _ _ 2)". • "Gain switching selection" in [Pr. PB26] is "Input device (gain switching (CDP)) (_ _ _ 1)". Switching during driving may cause a shock. Be sure to switch them after the servo motor or linear servo motor stops. Setting range: 0.0 to 300.0	0.0 [Hz]	<input type="radio"/>	<input type="radio"/>	<input type="radio"/>
PB34 VRF2B Vibration suppression control 1 - Resonance frequency after gain switching		Set the resonance frequency for vibration suppression control 1 for when the gain switching is enabled. When you set a value less than 0.1 Hz, the value will be the same as [Pr. PB20]. This parameter will be enabled only when the following conditions are fulfilled. <ul style="list-style-type: none"> • "Gain adjustment mode selection" in [Pr. PA08] is "Manual mode (_ _ _ 3)". • "Vibration suppression control 1 tuning mode selection" in [Pr. PB02] is "Manual setting (_ _ _ 2)". • "Gain switching selection" in [Pr. PB26] is "Input device (gain switching (CDP)) (_ _ _ 1)". Switching during driving may cause a shock. Be sure to switch them after the servo motor or linear servo motor stops. Setting range: 0.0 to 300.0	0.0 [Hz]	<input type="radio"/>	<input type="radio"/>	<input type="radio"/>
PB35 VRF3B Vibration suppression control 1 - Vibration frequency damping after gain switching		Set a damping of the vibration frequency for vibration suppression control 1 when the gain switching is enabled. This parameter will be enabled only when the following conditions are fulfilled. <ul style="list-style-type: none"> • "Gain adjustment mode selection" in [Pr. PA08] is "Manual mode (_ _ _ 3)". • "Vibration suppression control 1 tuning mode selection" in [Pr. PB02] is "Manual setting (_ _ _ 2)". • "Gain switching selection" in [Pr. PB26] is "Input device (gain switching (CDP)) (_ _ _ 1)". Switching during driving may cause a shock. Be sure to switch them after the servo motor or linear servo motor stops. Setting range: 0.00 to 0.30	0.00	<input type="radio"/>	<input type="radio"/>	<input type="radio"/>
PB36 VRF4B Vibration suppression control 1 - Resonance frequency damping after gain switching		Set a damping of the resonance frequency for vibration suppression control 1 when the gain switching is enabled. This parameter will be enabled only when the following conditions are fulfilled. <ul style="list-style-type: none"> • "Gain adjustment mode selection" in [Pr. PA08] is "Manual mode (_ _ _ 3)". • "Vibration suppression control 1 tuning mode selection" in [Pr. PB02] is "Manual setting (_ _ _ 2)". • "Gain switching selection" in [Pr. PB26] is "Input device (gain switching (CDP)) (_ _ _ 1)". Switching during driving may cause a shock. Be sure to switch them after the servo motor or linear servo motor stops. Setting range: 0.00 to 0.30	0.00	<input type="radio"/>	<input type="radio"/>	<input type="radio"/>

7. PARAMETERS

No./ symbol/name	Setting digit	Function	Initial value [unit]	Control mode																																																																																																																																																																																																																																												
				CP/BCD	CL	PS																																																																																																																																																																																																																																										
PB45	Set the command notch filter.																																																																																																																																																																																																																																															
CNHF Command notch filter	__ x x	Command notch filter setting frequency selection Refer to table 7.6 for the relation of setting values to frequency.	00h	○	○	○																																																																																																																																																																																																																																										
	_ x _ _	Notch depth selection Refer to table 7.7 for details.	0h	○	○	○																																																																																																																																																																																																																																										
	x _ _ _	For manufacturer setting	0h	▢	▢	▢																																																																																																																																																																																																																																										
<p>Table 7.6 Command notch filter setting frequency selection</p> <table border="1"> <thead> <tr> <th>Setting value</th> <th>Frequency [Hz]</th> <th>Setting value</th> <th>Frequency [Hz]</th> <th>Setting value</th> <th>Frequency [Hz]</th> </tr> </thead> <tbody> <tr><td>__ 0 0</td><td>Disabled</td><td>__ 2 0</td><td>70</td><td>__ 4 0</td><td>17.6</td></tr> <tr><td>__ 0 1</td><td>2250</td><td>__ 2 1</td><td>66</td><td>__ 4 1</td><td>16.5</td></tr> <tr><td>__ 0 2</td><td>1125</td><td>__ 2 2</td><td>62</td><td>__ 4 2</td><td>15.6</td></tr> <tr><td>__ 0 3</td><td>750</td><td>__ 2 3</td><td>59</td><td>__ 4 3</td><td>14.8</td></tr> <tr><td>__ 0 4</td><td>562</td><td>__ 2 4</td><td>56</td><td>__ 4 4</td><td>14.1</td></tr> <tr><td>__ 0 5</td><td>450</td><td>__ 2 5</td><td>53</td><td>__ 4 5</td><td>13.4</td></tr> <tr><td>__ 0 6</td><td>375</td><td>__ 2 6</td><td>51</td><td>__ 4 6</td><td>12.8</td></tr> <tr><td>__ 0 7</td><td>321</td><td>__ 2 7</td><td>48</td><td>__ 4 7</td><td>12.2</td></tr> <tr><td>__ 0 8</td><td>281</td><td>__ 2 8</td><td>46</td><td>__ 4 8</td><td>11.7</td></tr> <tr><td>__ 0 9</td><td>250</td><td>__ 2 9</td><td>45</td><td>__ 4 9</td><td>11.3</td></tr> <tr><td>__ 0 A</td><td>225</td><td>__ 2 A</td><td>43</td><td>__ 4 A</td><td>10.8</td></tr> <tr><td>__ 0 B</td><td>204</td><td>__ 2 B</td><td>41</td><td>__ 4 B</td><td>10.4</td></tr> <tr><td>__ 0 C</td><td>187</td><td>__ 2 C</td><td>40</td><td>__ 4 C</td><td>10</td></tr> <tr><td>__ 0 D</td><td>173</td><td>__ 2 D</td><td>38</td><td>__ 4 D</td><td>9.7</td></tr> <tr><td>__ 0 E</td><td>160</td><td>__ 2 E</td><td>37</td><td>__ 4 E</td><td>9.4</td></tr> <tr><td>__ 0 F</td><td>150</td><td>__ 2 F</td><td>36</td><td>__ 4 F</td><td>9.1</td></tr> <tr><td>__ 1 0</td><td>140</td><td>__ 3 0</td><td>35.2</td><td>__ 5 0</td><td>8.8</td></tr> <tr><td>__ 1 1</td><td>132</td><td>__ 3 1</td><td>33.1</td><td>__ 5 1</td><td>8.3</td></tr> <tr><td>__ 1 2</td><td>125</td><td>__ 3 2</td><td>31.3</td><td>__ 5 2</td><td>7.8</td></tr> <tr><td>__ 1 3</td><td>118</td><td>__ 3 3</td><td>29.6</td><td>__ 5 3</td><td>7.4</td></tr> <tr><td>__ 1 4</td><td>112</td><td>__ 3 4</td><td>28.1</td><td>__ 5 4</td><td>7.0</td></tr> <tr><td>__ 1 5</td><td>107</td><td>__ 3 5</td><td>26.8</td><td>__ 5 5</td><td>6.7</td></tr> <tr><td>__ 1 6</td><td>102</td><td>__ 3 6</td><td>25.6</td><td>__ 5 6</td><td>6.4</td></tr> <tr><td>__ 1 7</td><td>97</td><td>__ 3 7</td><td>24.5</td><td>__ 5 7</td><td>6.1</td></tr> <tr><td>__ 1 8</td><td>93</td><td>__ 3 8</td><td>23.4</td><td>__ 5 8</td><td>5.9</td></tr> <tr><td>__ 1 9</td><td>90</td><td>__ 3 9</td><td>22.5</td><td>__ 5 9</td><td>5.6</td></tr> <tr><td>__ 1 A</td><td>86</td><td>__ 3 A</td><td>21.6</td><td>__ 5 A</td><td>5.4</td></tr> <tr><td>__ 1 B</td><td>83</td><td>__ 3 B</td><td>20.8</td><td>__ 5 B</td><td>5.2</td></tr> <tr><td>__ 1 C</td><td>80</td><td>__ 3 C</td><td>20.1</td><td>__ 5 C</td><td>5.0</td></tr> <tr><td>__ 1 D</td><td>77</td><td>__ 3 D</td><td>19.4</td><td>__ 5 D</td><td>4.9</td></tr> <tr><td>__ 1 E</td><td>75</td><td>__ 3 E</td><td>18.8</td><td>__ 5 E</td><td>4.7</td></tr> <tr><td>__ 1 F</td><td>72</td><td>__ 3 F</td><td>18.2</td><td>__ 5 F</td><td>4.5</td></tr> </tbody> </table> <p>Table 7.7 Notch depth selection</p> <table border="1"> <thead> <tr> <th>Setting value</th> <th>Depth [dB]</th> <th>Setting value</th> <th>Depth [dB]</th> </tr> </thead> <tbody> <tr><td>_ 0 _ _</td><td>-40.0</td><td>_ 8 _ _</td><td>-6.0</td></tr> <tr><td>_ 1 _ _</td><td>-24.1</td><td>_ 9 _ _</td><td>-5.0</td></tr> <tr><td>_ 2 _ _</td><td>-18.1</td><td>_ A _ _</td><td>-4.1</td></tr> <tr><td>_ 3 _ _</td><td>-14.5</td><td>_ B _ _</td><td>-3.3</td></tr> <tr><td>_ 4 _ _</td><td>-12.0</td><td>_ C _ _</td><td>-2.5</td></tr> <tr><td>_ 5 _ _</td><td>-10.1</td><td>_ D _ _</td><td>-1.8</td></tr> <tr><td>_ 6 _ _</td><td>-8.5</td><td>_ E _ _</td><td>-1.2</td></tr> <tr><td>_ 7 _ _</td><td>-7.2</td><td>_ F _ _</td><td>-0.6</td></tr> </tbody> </table>							Setting value	Frequency [Hz]	Setting value	Frequency [Hz]	Setting value	Frequency [Hz]	__ 0 0	Disabled	__ 2 0	70	__ 4 0	17.6	__ 0 1	2250	__ 2 1	66	__ 4 1	16.5	__ 0 2	1125	__ 2 2	62	__ 4 2	15.6	__ 0 3	750	__ 2 3	59	__ 4 3	14.8	__ 0 4	562	__ 2 4	56	__ 4 4	14.1	__ 0 5	450	__ 2 5	53	__ 4 5	13.4	__ 0 6	375	__ 2 6	51	__ 4 6	12.8	__ 0 7	321	__ 2 7	48	__ 4 7	12.2	__ 0 8	281	__ 2 8	46	__ 4 8	11.7	__ 0 9	250	__ 2 9	45	__ 4 9	11.3	__ 0 A	225	__ 2 A	43	__ 4 A	10.8	__ 0 B	204	__ 2 B	41	__ 4 B	10.4	__ 0 C	187	__ 2 C	40	__ 4 C	10	__ 0 D	173	__ 2 D	38	__ 4 D	9.7	__ 0 E	160	__ 2 E	37	__ 4 E	9.4	__ 0 F	150	__ 2 F	36	__ 4 F	9.1	__ 1 0	140	__ 3 0	35.2	__ 5 0	8.8	__ 1 1	132	__ 3 1	33.1	__ 5 1	8.3	__ 1 2	125	__ 3 2	31.3	__ 5 2	7.8	__ 1 3	118	__ 3 3	29.6	__ 5 3	7.4	__ 1 4	112	__ 3 4	28.1	__ 5 4	7.0	__ 1 5	107	__ 3 5	26.8	__ 5 5	6.7	__ 1 6	102	__ 3 6	25.6	__ 5 6	6.4	__ 1 7	97	__ 3 7	24.5	__ 5 7	6.1	__ 1 8	93	__ 3 8	23.4	__ 5 8	5.9	__ 1 9	90	__ 3 9	22.5	__ 5 9	5.6	__ 1 A	86	__ 3 A	21.6	__ 5 A	5.4	__ 1 B	83	__ 3 B	20.8	__ 5 B	5.2	__ 1 C	80	__ 3 C	20.1	__ 5 C	5.0	__ 1 D	77	__ 3 D	19.4	__ 5 D	4.9	__ 1 E	75	__ 3 E	18.8	__ 5 E	4.7	__ 1 F	72	__ 3 F	18.2	__ 5 F	4.5	Setting value	Depth [dB]	Setting value	Depth [dB]	_ 0 _ _	-40.0	_ 8 _ _	-6.0	_ 1 _ _	-24.1	_ 9 _ _	-5.0	_ 2 _ _	-18.1	_ A _ _	-4.1	_ 3 _ _	-14.5	_ B _ _	-3.3	_ 4 _ _	-12.0	_ C _ _	-2.5	_ 5 _ _	-10.1	_ D _ _	-1.8	_ 6 _ _	-8.5	_ E _ _	-1.2	_ 7 _ _	-7.2	_ F _ _	-0.6
Setting value	Frequency [Hz]	Setting value	Frequency [Hz]	Setting value	Frequency [Hz]																																																																																																																																																																																																																																											
__ 0 0	Disabled	__ 2 0	70	__ 4 0	17.6																																																																																																																																																																																																																																											
__ 0 1	2250	__ 2 1	66	__ 4 1	16.5																																																																																																																																																																																																																																											
__ 0 2	1125	__ 2 2	62	__ 4 2	15.6																																																																																																																																																																																																																																											
__ 0 3	750	__ 2 3	59	__ 4 3	14.8																																																																																																																																																																																																																																											
__ 0 4	562	__ 2 4	56	__ 4 4	14.1																																																																																																																																																																																																																																											
__ 0 5	450	__ 2 5	53	__ 4 5	13.4																																																																																																																																																																																																																																											
__ 0 6	375	__ 2 6	51	__ 4 6	12.8																																																																																																																																																																																																																																											
__ 0 7	321	__ 2 7	48	__ 4 7	12.2																																																																																																																																																																																																																																											
__ 0 8	281	__ 2 8	46	__ 4 8	11.7																																																																																																																																																																																																																																											
__ 0 9	250	__ 2 9	45	__ 4 9	11.3																																																																																																																																																																																																																																											
__ 0 A	225	__ 2 A	43	__ 4 A	10.8																																																																																																																																																																																																																																											
__ 0 B	204	__ 2 B	41	__ 4 B	10.4																																																																																																																																																																																																																																											
__ 0 C	187	__ 2 C	40	__ 4 C	10																																																																																																																																																																																																																																											
__ 0 D	173	__ 2 D	38	__ 4 D	9.7																																																																																																																																																																																																																																											
__ 0 E	160	__ 2 E	37	__ 4 E	9.4																																																																																																																																																																																																																																											
__ 0 F	150	__ 2 F	36	__ 4 F	9.1																																																																																																																																																																																																																																											
__ 1 0	140	__ 3 0	35.2	__ 5 0	8.8																																																																																																																																																																																																																																											
__ 1 1	132	__ 3 1	33.1	__ 5 1	8.3																																																																																																																																																																																																																																											
__ 1 2	125	__ 3 2	31.3	__ 5 2	7.8																																																																																																																																																																																																																																											
__ 1 3	118	__ 3 3	29.6	__ 5 3	7.4																																																																																																																																																																																																																																											
__ 1 4	112	__ 3 4	28.1	__ 5 4	7.0																																																																																																																																																																																																																																											
__ 1 5	107	__ 3 5	26.8	__ 5 5	6.7																																																																																																																																																																																																																																											
__ 1 6	102	__ 3 6	25.6	__ 5 6	6.4																																																																																																																																																																																																																																											
__ 1 7	97	__ 3 7	24.5	__ 5 7	6.1																																																																																																																																																																																																																																											
__ 1 8	93	__ 3 8	23.4	__ 5 8	5.9																																																																																																																																																																																																																																											
__ 1 9	90	__ 3 9	22.5	__ 5 9	5.6																																																																																																																																																																																																																																											
__ 1 A	86	__ 3 A	21.6	__ 5 A	5.4																																																																																																																																																																																																																																											
__ 1 B	83	__ 3 B	20.8	__ 5 B	5.2																																																																																																																																																																																																																																											
__ 1 C	80	__ 3 C	20.1	__ 5 C	5.0																																																																																																																																																																																																																																											
__ 1 D	77	__ 3 D	19.4	__ 5 D	4.9																																																																																																																																																																																																																																											
__ 1 E	75	__ 3 E	18.8	__ 5 E	4.7																																																																																																																																																																																																																																											
__ 1 F	72	__ 3 F	18.2	__ 5 F	4.5																																																																																																																																																																																																																																											
Setting value	Depth [dB]	Setting value	Depth [dB]																																																																																																																																																																																																																																													
_ 0 _ _	-40.0	_ 8 _ _	-6.0																																																																																																																																																																																																																																													
_ 1 _ _	-24.1	_ 9 _ _	-5.0																																																																																																																																																																																																																																													
_ 2 _ _	-18.1	_ A _ _	-4.1																																																																																																																																																																																																																																													
_ 3 _ _	-14.5	_ B _ _	-3.3																																																																																																																																																																																																																																													
_ 4 _ _	-12.0	_ C _ _	-2.5																																																																																																																																																																																																																																													
_ 5 _ _	-10.1	_ D _ _	-1.8																																																																																																																																																																																																																																													
_ 6 _ _	-8.5	_ E _ _	-1.2																																																																																																																																																																																																																																													
_ 7 _ _	-7.2	_ F _ _	-0.6																																																																																																																																																																																																																																													

7. PARAMETERS

No./ symbol/name	Setting digit	Function	Initial value [unit]	Control mode		
				CP/BCD	OL	PS
PB46 NH3 Machine resonance suppression filter 3		Set the notch frequency of the machine resonance suppression filter 3. To enable the setting value, select "Enabled (_ _ _ 1)" of "Machine resonance suppression filter 3 selection" in [Pr. PB47]. Setting range: 10 to 4500	4500 [Hz]	<input type="radio"/>	<input type="radio"/>	<input type="radio"/>
PB47 NHQ3 Notch shape selection 3	Set forms of the machine resonance suppression filter 3.					
	_ _ _ x	Machine resonance suppression filter 3 selection 0: Disabled 1: Enabled	0h	<input type="radio"/>	<input type="radio"/>	<input type="radio"/>
	_ _ x _	Notch depth selection 0: -40 dB 1: -14 dB 2: -8 dB 3: -4 dB	0h	<input type="radio"/>	<input type="radio"/>	<input type="radio"/>
	_ x _ _	Notch width selection 0: $\alpha = 2$ 1: $\alpha = 3$ 2: $\alpha = 4$ 3: $\alpha = 5$	0h	<input type="radio"/>	<input type="radio"/>	<input type="radio"/>
	x _ _ _	For manufacturer setting	0h	<input type="checkbox"/>	<input type="checkbox"/>	<input type="checkbox"/>
PB48 NH4 Machine resonance suppression filter 4		Set the notch frequency of the machine resonance suppression filter 4. To enable the setting value, select "Enabled (_ _ _ 1)" of "Machine resonance suppression filter 4 selection" in [Pr. PB49]. Setting range: 10 to 4500	4500 [Hz]	<input type="radio"/>	<input type="radio"/>	<input type="radio"/>
PB49 NHQ4 Notch shape selection 4	Set forms of the machine resonance suppression filter 4.					
	_ _ _ x	Machine resonance suppression filter 4 selection 0: Disabled 1: Enabled When you select "Enabled" of this digit, [Pr. PB17 Shaft resonance suppression filter] is not available.	0h	<input type="radio"/>	<input type="radio"/>	<input type="radio"/>
	_ _ x _	Notch depth selection 0: -40 dB 1: -14 dB 2: -8 dB 3: -4 dB	0h	<input type="radio"/>	<input type="radio"/>	<input type="radio"/>
	_ x _ _	Notch width selection 0: $\alpha = 2$ 1: $\alpha = 3$ 2: $\alpha = 4$ 3: $\alpha = 5$	0h	<input type="radio"/>	<input type="radio"/>	<input type="radio"/>
	x _ _ _	For manufacturer setting	0h	<input type="checkbox"/>	<input type="checkbox"/>	<input type="checkbox"/>
PB50 NH5 Machine resonance suppression filter 5		Set the notch frequency of the machine resonance suppression filter 5. To enable the setting value, select "Enabled (_ _ _ 1)" of "Machine resonance suppression filter 5 selection" in [Pr. PB51]. Setting range: 10 to 4500	4500 [Hz]	<input type="radio"/>	<input type="radio"/>	<input type="radio"/>

7. PARAMETERS

No./ symbol/name	Setting digit	Function	Initial value [unit]	Control mode		
				CP/BCD	OL	PS
PB51 NHQ5 Notch shape selection 5	Set forms of the machine resonance suppression filter 5. When you select "Enabled (_ _ _ 1)" of "Robust filter selection" in [Pr. PE41], the machine resonance suppression filter 5 is not available.					
	_ _ _ x	Machine resonance suppression filter 5 selection 0: Disabled 1: Enabled	0h	<input type="radio"/>	<input type="radio"/>	<input type="radio"/>
	_ _ x _	Notch depth selection 0: -40 dB 1: -14 dB 2: -8 dB 3: -4 dB	0h	<input type="radio"/>	<input type="radio"/>	<input type="radio"/>
	_ x _ _	Notch width selection 0: $\alpha = 2$ 1: $\alpha = 3$ 2: $\alpha = 4$ 3: $\alpha = 5$	0h	<input type="radio"/>	<input type="radio"/>	<input type="radio"/>
	x _ _ _	For manufacturer setting	0h	<input type="radio"/>	<input type="radio"/>	<input type="radio"/>
PB52 VRF21 Vibration suppression control 2 - Vibration frequency		Set the vibration frequency for vibration suppression control 2 to suppress low-frequency machine vibration. When "Vibration suppression control 2 tuning mode selection" is set to "Automatic setting (_ _ 1 _)" in [Pr. PB02], this parameter will be set automatically. When "Manual setting (_ _ 2 _)" is selected, the setting written to the parameter is used. To enable the setting value, set "Vibration suppression mode selection" to "3 inertia mode (_ _ _ 1)" in [Pr. PA24]. Setting range: 0.1 to 300.0	100.0 [Hz]	<input type="radio"/>	<input type="radio"/>	<input type="radio"/>
PB53 VRF22 Vibration suppression control 2 - Resonance frequency		Set the resonance frequency for vibration suppression control 2 to suppress low-frequency machine vibration. When "Vibration suppression control 2 tuning mode selection" is set to "Automatic setting (_ _ 1 _)" in [Pr. PB02], this parameter will be set automatically. When "Manual setting (_ _ 2 _)" is selected, the setting written to the parameter is used. To enable the setting value, set "Vibration suppression mode selection" to "3 inertia mode (_ _ _ 1)" in [Pr. PA24]. Setting range: 0.1 to 300.0	100.0 [Hz]	<input type="radio"/>	<input type="radio"/>	<input type="radio"/>
PB54 VRF23 Vibration suppression control 2 - Vibration frequency damping		Set a damping of the vibration frequency for vibration suppression control 2 to suppress low-frequency machine vibration. When "Vibration suppression control 2 tuning mode selection" is set to "Automatic setting (_ _ 1 _)" in [Pr. PB02], this parameter will be set automatically. When "Manual setting (_ _ 2 _)" is selected, the setting written to the parameter is used. To enable the setting value, set "Vibration suppression mode selection" to "3 inertia mode (_ _ _ 1)" in [Pr. PA24]. Setting range: 0.00 to 0.30	0.00	<input type="radio"/>	<input type="radio"/>	<input type="radio"/>
PB55 VRF24 Vibration suppression control 2 - Resonance frequency damping		Set a damping of the resonance frequency for vibration suppression control 2 to suppress low-frequency machine vibration. When "Vibration suppression control 2 tuning mode selection" is set to "Automatic setting (_ _ 1 _)" in [Pr. PB02], this parameter will be set automatically. When "Manual setting (_ _ 2 _)" is selected, the setting written to the parameter is used. To enable the setting value, set "Vibration suppression mode selection" to "3 inertia mode (_ _ _ 1)" in [Pr. PA24]. Setting range: 0.00 to 0.30	0.00	<input type="radio"/>	<input type="radio"/>	<input type="radio"/>

7. PARAMETERS

No./ symbol/name	Setting digit	Function	Initial value [unit]	Control mode		
				CP/BCD	OL	PS
PB56 VRF21B Vibration suppression control 2 - Vibration frequency after gain switching		<p>Set the vibration frequency for vibration suppression control 2 for when the gain switching is enabled.</p> <p>When you set a value less than 0.1 Hz, the value will be the same as [Pr. PB52]. This parameter will be enabled only when the following conditions are fulfilled.</p> <ul style="list-style-type: none"> • "Gain adjustment mode selection" in [Pr. PA08] is "Manual mode (_ _ _ 3)". • "Vibration suppression mode selection" in [Pr. PA24] is "3 inertia mode (_ _ _ 1)". • "Vibration suppression control 2 tuning mode selection" in [Pr. PB02] is "Manual setting (_ _ 2 _)". • "Gain switching selection" in [Pr. PB26] is "Input device (gain switching (CDP)) (_ _ 1)". <p>Switching during driving may cause a shock. Be sure to switch them after the servo motor or linear servo motor stops.</p> <p>Setting range: 0.0 to 300.0</p>	0.0 [Hz]	<input type="radio"/>	<input type="radio"/>	<input type="radio"/>
PB57 VRF22B Vibration suppression control 2 - Resonance frequency after gain switching		<p>Set the resonance frequency for vibration suppression control 2 for when the gain switching is enabled.</p> <p>When you set a value less than 0.1 Hz, the value will be the same as [Pr. PB53]. This parameter will be enabled only when the following conditions are fulfilled.</p> <ul style="list-style-type: none"> • "Gain adjustment mode selection" in [Pr. PA08] is "Manual mode (_ _ _ 3)". • "Vibration suppression mode selection" in [Pr. PA24] is "3 inertia mode (_ _ _ 1)". • "Vibration suppression control 2 tuning mode selection" in [Pr. PB02] is "Manual setting (_ _ 2 _)". • "Gain switching selection" in [Pr. PB26] is "Input device (gain switching (CDP)) (_ _ 1)". <p>Switching during driving may cause a shock. Be sure to switch them after the servo motor or linear servo motor stops.</p> <p>Setting range: 0.0 to 300.0</p>	0.0 [Hz]	<input type="radio"/>	<input type="radio"/>	<input type="radio"/>
PB58 VRF23B Vibration suppression control 2 - Vibration frequency damping after gain switching		<p>Set a damping of the vibration frequency for vibration suppression control 2 when the gain switching is enabled.</p> <p>This parameter will be enabled only when the following conditions are fulfilled.</p> <ul style="list-style-type: none"> • "Gain adjustment mode selection" in [Pr. PA08] is "Manual mode (_ _ _ 3)". • "Vibration suppression mode selection" in [Pr. PA24] is "3 inertia mode (_ _ _ 1)". • "Vibration suppression control 2 tuning mode selection" in [Pr. PB02] is "Manual setting (_ _ 2 _)". • "Gain switching selection" in [Pr. PB26] is "Input device (gain switching (CDP)) (_ _ 1)". <p>Switching during driving may cause a shock. Be sure to switch them after the servo motor or linear servo motor stops.</p> <p>Setting range: 0.00 to 0.30</p>	0.00	<input type="radio"/>	<input type="radio"/>	<input type="radio"/>
PB59 VRF24B Vibration suppression control 2 - Resonance frequency damping after gain switching		<p>Set a damping of the resonance frequency for vibration suppression control 2 when the gain switching is enabled.</p> <p>This parameter will be enabled only when the following conditions are fulfilled.</p> <ul style="list-style-type: none"> • "Gain adjustment mode selection" in [Pr. PA08] is "Manual mode (_ _ _ 3)". • "Vibration suppression mode selection" in [Pr. PA24] is "3 inertia mode (_ _ _ 1)". • "Vibration suppression control 2 tuning mode selection" in [Pr. PB02] is "Manual setting (_ _ 2 _)". • "Gain switching selection" in [Pr. PB26] is "Input device (gain switching (CDP)) (_ _ 1)". <p>Switching during driving may cause a shock. Be sure to switch them after the servo motor or linear servo motor stops.</p> <p>Setting range: 0.00 to 0.30</p>	0.00	<input type="radio"/>	<input type="radio"/>	<input type="radio"/>

7. PARAMETERS

No./ symbol/name	Setting digit	Function	Initial value [unit]	Control mode		
				CP/BCD	CL	PS
PB60 PG1B Model loop gain after gain switching		<p>Set the model loop gain for when the gain switching is enabled.</p> <p>When you set a value less than 1.0 rad/s, the value will be the same as [Pr. PB07].</p> <p>This parameter will be enabled only when the following conditions are fulfilled.</p> <ul style="list-style-type: none"> • "Gain adjustment mode selection" in [Pr. PA08] is "Manual mode (___3)". • "Gain switching selection" in [Pr. PB26] is "Input device (gain switching (CDP)) (___1)". <p>Switching during driving may cause a shock. Be sure to switch them after the servo motor or linear servo motor stops.</p> <p>Setting range: 0.0 to 2000.0</p>	0.0 [rad/s]	<input type="radio"/>	<input type="radio"/>	<input type="radio"/>

7.2.3 Extension setting parameters ([Pr. PC__])

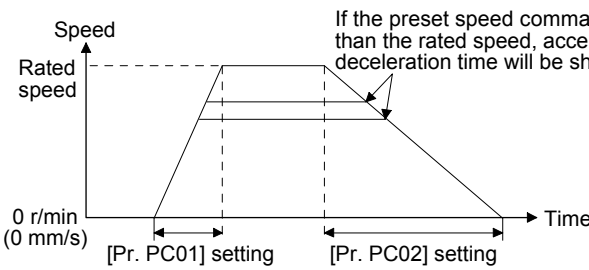
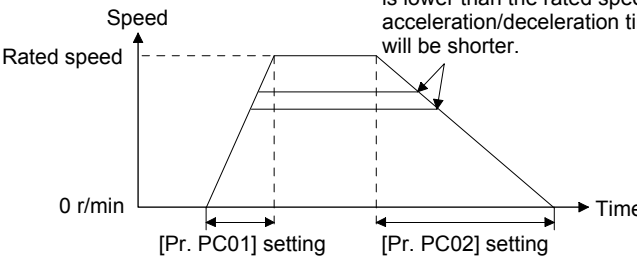
No./ symbol/name	Setting digit	Function	Initial value [unit]	Control mode		
				CP/BCD	CL	PS
PC01 STA JOG operation acceleration time constant		<p>Set an acceleration time constant for the JOG operation of the program method.</p> <p>Set an acceleration time from 0 r/min or 0 mm/s to the rated speed.</p>  <p>For example for the servo motor of 3000 r/min rated speed, set 3000 (3 s) to increase speed from 0 r/min to 1000 r/min in 1 s.</p> <p>Additionally, when 20000 ms or more value is set, it will be clamped to 20000 ms.</p> <p>Setting range: 0 to 50000</p>	0 [ms]	<input type="radio"/>	<input type="radio"/>	<input type="radio"/>
PC01 STA Acceleration time constant 1		<p>Set an acceleration time constant for the automatic operation of the indexer method.</p> <p>Set an acceleration time from 0 r/min to the rated speed.</p>  <p>For example for the servo motor of 3000 r/min rated speed, set 3000 (3 s) to increase speed from 0 r/min to 1000 r/min in 1 s.</p> <p>Additionally, when 20000 ms or more value is set, it will be clamped to 20000 ms.</p> <p>Setting range: 0 to 50000</p>	0 [ms]	<input type="radio"/>	<input type="radio"/>	<input type="radio"/>
PC02 STB JOG operation deceleration time constant		<p>Set a deceleration time constant for the JOG operation of the program method.</p> <p>Set a deceleration time from the rated speed to 0 r/min or 0 mm/s.</p> <p>Additionally, when 20000 ms or more value is set, it will be clamped to 20000 ms.</p> <p>Setting range: 0 to 50000</p>	0 [ms]	<input type="radio"/>	<input type="radio"/>	<input type="radio"/>

7. PARAMETERS

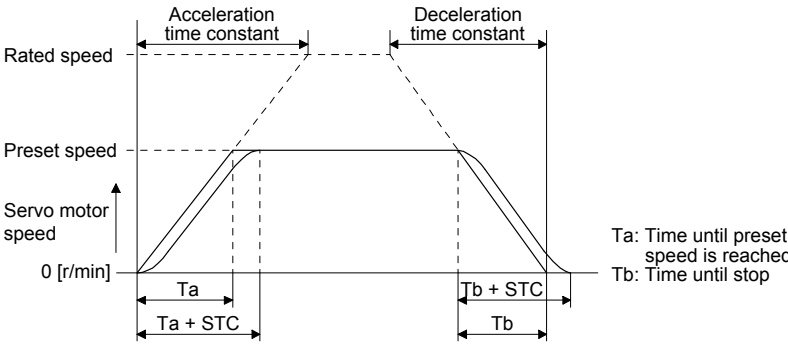
No./ symbol/name	Setting digit	Function	Initial value [unit]	Control mode		
				CP/BCD	CL	PS
PC02 STB Deceleration time constant 1		Set a deceleration time constant for the automatic operation of the indexer method. Set a deceleration time from the rated speed to 0 r/min. Additionally, when 20000 ms or more value is set, it will be clamped to 20000 ms. Setting range: 0 to 50000	0 [ms]			○
PC03 *STC S-pattern acceleration/ deceleration time constant		This enables to start/stop the servo motor or linear servo motor smoothly. Set the time of the arc part for S-pattern acceleration/deceleration. Setting "0" will make it linear acceleration/deceleration. Servo is usually operated with linear acceleration and deceleration; however, smooth start and stop are enabled by setting [Pr. PC03 S-pattern acceleration/deceleration time constants]. When the S-pattern acceleration/deceleration time constants are set, smooth positioning is enabled as shown in the following figure. Note that when it is set, a time period from the start to output of MEND (Travel completion) is longer by the S-pattern acceleration/deceleration time constants.  <p>Ta: Time until preset speed is reached Tb: Time until stop</p> When the STC value is set longer than the constant speed time, the speed may not reach to the command speed. Additionally, when a value of 1000 ms or more is set, it will be clamped to 1000 ms. Setting range: 0 to 5000	0 [ms]	○	○	
PC05 SC1 Automatic operation speed 1		Set a positioning speed for the automatic operation speed 1, 2 of the indexer method. Setting range: 0 to permissible instantaneous speed	100 [r/min]			○
PC06 SC2 Automatic operation speed 2		Set a positioning speed for the automatic operation speed 1, 2 of the indexer method. Setting range: 0 to permissible instantaneous speed	500 [r/min]			○
PC07 SC3 Manual operation speed 1		Set a JOG speed of the manual operation mode, JOG operation, and home position return mode of the indexer method. Setting range: 0 to permissible instantaneous speed	1000 [r/min]			○

7. PARAMETERS

No./ symbol/name	Setting digit	Function	Initial value [unit]	Control mode		
				CP/BCD	CL	PS
PC14 MOD1 Analog monitor 1 output	__ x x	Analog monitor 1 output selection Select a signal to output to MO1 (Analog monitor 1). Refer to app. 8.3 of "MR-J4-_A_(-RJ) Servo Amplifier Instruction Manual" for detection points of output selection. Refer to table 7.8 or 7.9 for settings.	00h	○	○	○
	_ x _ _	For manufacturer setting	0h	/	/	/
	x _ _ _		0h	/	/	/

Table 7.8 Analog monitor setting value (MR-J4-_A_-RJ 100 W or more)

Setting value	Item	Operation mode (Note 1)			
		Standard	Full.	Lin.	DD
__ 0 0	(Linear) servo motor speed (±8 V/max. speed)	○	○	○	○
__ 0 1	Torque or thrust (±8 V/max. torque or max. thrust) (Note 3)	○	○	○	○
__ 0 2	(Linear) servo motor speed (+8 V/max. speed)	○	○	○	○
__ 0 3	Torque or thrust (+8 V/max. torque or max. thrust) (Note 3)	○	○	○	○
__ 0 4	Current command (±8 V/max. current command)	○	○	○	○
__ 0 5	Command pulse frequency (±10 V/±4 Mpulses/s)	○	○	○	○
__ 0 6	Servo motor-side droop pulses (±10 V/100 pulses) (Note 2)	○	○	○	○
__ 0 7	Servo motor-side droop pulses (±10 V/1000 pulses) (Note 2)	○	○	○	○
__ 0 8	Servo motor-side droop pulses (±10 V/10000 pulses) (Note 2)	○	○	○	○
__ 0 9	Servo motor-side droop pulses (±10 V/100000 pulses) (Note 2)	○	○	○	○
__ 0 A	Feedback position (±10 V/1 Mpulses) (Note 2)	○	/	/	/
__ 0 B	Feedback position (±10 V/10 Mpulses) (Note 2)	○	/	/	/
__ 0 C	Feedback position (±10 V/100 Mpulses) (Note 2)	○	/	/	/
__ 0 D	Bus voltage (200 V class and 100 V class: +8 V/400 V, 400 V class: +8 V/800 V)	○	○	○	○
__ 0 E	Speed command 2 (±8 V/max. speed)	○	○	○	○
__ 1 0	Load-side droop pulses (±10 V/100 pulses) (Note 2)	/	○	/	/
__ 1 1	Load-side droop pulses (±10 V/1000 pulses) (Note 2)	/	○	/	/
__ 1 2	Load-side droop pulses (±10 V/10000 pulses) (Note 2)	/	○	/	/
__ 1 3	Load-side droop pulses (±10 V/100000 pulses) (Note 2)	/	○	/	/
__ 1 4	Load-side droop pulses (±10 V/1 Mpulses) (Note 2)	/	○	/	/
__ 1 5	Servo motor-side/load-side position deviation (±10 V/100000 pulses)	/	○	/	/
__ 1 6	Servo motor-side/load-side speed deviation (±8 V/max. speed)	/	○	/	/
__ 1 7	Internal temperature of encoder (±10 V/±128 °C)	○	○	/	○

- Note 1. Items with ○ are available for each operation mode.
 Standard: Standard (semi closed loop system) use of the rotary servo motor
 Full.: Fully closed loop system use of the rotary servo motor
 Lin.: Linear servo motor use
 DD: Direct drive (DD) motor use
2. Encoder pulse unit
3. The value in [Pr. PA11] or [Pr. PA12] whichever is higher is applied for the maximum torque or maximum thrust.

7. PARAMETERS

No./ symbol/name	Setting digit	Function	Initial value [unit]	Control mode		
				CP/BCD	CL	PS
PC14 MOD1 Analog monitor 1 output	Table 7.9 Analog monitor setting value (MR-J4-03A6-RJ)					
		Setting value	Item			
		-- 0 0	Servo motor speed (5 V ± 3 V/max. speed)			
		-- 0 1	Torque (5 V ± 3 V/max. torque) (Note 2)			
		-- 0 2	Servo motor speed (5 V + 3 V/max. speed)			
		-- 0 3	Torque (5 V + 3 V/max. torque) (Note 2)			
		-- 0 4	Current command (5 V ± 3 V/max. current command)			
		-- 0 5	Command pulse frequency (5 V ± 4 V/±4 Mpulses/s)			
		-- 0 6	Servo motor-side droop pulses (5 V ± 4 V/100 pulses) (Note 1)			
		-- 0 7	Servo motor-side droop pulses (5 V ± 4 V/1000 pulses) (Note 1)			
		-- 0 8	Servo motor-side droop pulses (5 V ± 4 V/10000 pulses) (Note 1)			
		-- 0 9	Servo motor-side droop pulses (5 V ± 4 V/100000 pulses) (Note 1)			
		-- 0 A	Feedback position (5 V ± 4 V/1 Mpulses) (Note 1)			
		-- 0 B	Feedback position (5 V ± 4 V/10 Mpulses) (Note 1)			
		-- 0 C	Feedback position (5 V ± 4 V/100 Mpulses) (Note 1)			
	-- 0 D	Bus voltage (5 V + 4 V/100 V)				
	-- 0 E	Speed command 2 (5 V ± 3 V/max. speed)				
	-- 1 7	Internal temperature of encoder (5 V ± 4 V/±128 °C)				
		Note 1. Encoder pulse unit				
		2. The value in [Pr. PA11] or [Pr. PA12] whichever is higher is applied for the maximum torque.				
PC15 MOD2 Analog monitor 2 output	-- x x	Analog monitor 2 output selection Select a signal to output to MO2 (Analog monitor 2). Refer to app. 8.3 of "MR-J4-A_(-RJ) Servo Amplifier Instruction Manual" for detection points of output selection. Refer to [Pr. PC14] for settings.	01h	<input type="radio"/>	<input type="radio"/>	<input type="radio"/>
	-- x --	For manufacturer setting	0h	<input type="checkbox"/>	<input type="checkbox"/>	<input type="checkbox"/>
	x -- --		0h	<input type="checkbox"/>	<input type="checkbox"/>	<input type="checkbox"/>
PC16 MBR Electromagnetic brake sequence output	/	Set the delay time between MBR (Electromagnetic brake interlock) and the base drive circuit is shut-off. Setting range: 0 to 1000	0 [ms]	<input type="radio"/>	<input type="radio"/>	<input type="radio"/>
	/	Set an output range of ZSP (Zero speed detection). ZSP (Zero speed detection) has hysteresis of 20 r/min or 20 mm/s. Setting range: 0 to 10000	50 [r/min]/ [mm/s]	<input type="radio"/>	<input type="radio"/>	<input type="radio"/>
PC18 *BPS Alarm history clear	--- x	Alarm history clear selection Used to clear the alarm history. 0: Disabled 1: Enabled When "Enabled" is set, the alarm history will be cleared at the next power-on. After the alarm history is cleared, the setting is automatically disabled.	0h	<input type="radio"/>	<input type="radio"/>	<input type="radio"/>
	--- x --	For manufacturer setting	0h	<input type="checkbox"/>	<input type="checkbox"/>	<input type="checkbox"/>
	-- x --		0h	<input type="checkbox"/>	<input type="checkbox"/>	<input type="checkbox"/>
	x -- --		0h	<input type="checkbox"/>	<input type="checkbox"/>	<input type="checkbox"/>

7. PARAMETERS

No./ symbol/name	Setting digit	Function	Initial value [unit]	Control mode													
				CP/BCD	CL	PS											
PC19 *ENRS Encoder output pulse selection	___x	Encoder output pulse phase selection Select an encoder pulse direction. 0: Increasing A-phase 90° in CCW or positive direction 1: Increasing A-phase 90° in CW or negative direction <table border="1" style="margin: 10px auto;"> <thead> <tr> <th rowspan="2">Setting value</th> <th colspan="2">Servo motor rotation direction/linear servo motor travel direction</th> </tr> <tr> <th>CCW or positive direction</th> <th>CW or negative direction</th> </tr> </thead> <tbody> <tr> <td>0</td> <td>A-phase </td> <td>A-phase </td> </tr> <tr> <td>1</td> <td>A-phase </td> <td>A-phase </td> </tr> </tbody> </table>	Setting value	Servo motor rotation direction/linear servo motor travel direction		CCW or positive direction	CW or negative direction	0	A-phase	A-phase	1	A-phase	A-phase	0h	<input type="radio"/>	<input type="radio"/>	<input type="radio"/>
	Setting value	Servo motor rotation direction/linear servo motor travel direction															
		CCW or positive direction	CW or negative direction														
	0	A-phase	A-phase														
1	A-phase	A-phase															
__x_	Encoder output pulse setting selection 0: Output pulse setting 1: Division ratio setting 2: The same output pulse setting as command pulse 3: A-phase/B-phase pulse electronic gear setting 4: A/B-phase pulse through output setting 5: Command pulse input through output setting When you select "1", the settings of [Pr. PA16 Encoder output pulses 2] will be disabled. When you select "2", the settings of [Pr. PA15 Encoder output pulses] and [Pr. PA16 Encoder output pulses 2] will be disabled. Additionally, it will be the servo motor side pulse unit for the indexer method. When you select the setting, do not change the settings in [Pr. PA06] and [Pr. PA07] after the power-on. Setting "4" will be enabled only when A/B/Z-phase differential output linear encoder is used. And "Encoder output pulse phase selection (___x)" will be disabled. When another encoder is connected, [AL. 37 Parameter error] will occur. Setting "Standard control mode (___0_)" in [Pr. PA01] will trigger [AL. 37 Parameter error]. When "5" is set, the settings of [Pr. PA15 Encoder output pulses] and [Pr. PA16 Encoder output pulses 2] will be disabled. "Encoder output pulse phase selection (___x)" and "Encoder selection for encoder output pulse (x__)" will be also disabled. When [Pr. PA01] is set to other than "Point table method (___6)" and "Program method (___7)", [AL. 37 Parameter error] occurs. When "5" is set, assign PP/PP2 with [Pr. PD44] and NP/NP2 with [Pr. PD46].	0h	<input type="radio"/>	<input type="radio"/>	<input type="radio"/>												
_x__	Selection of the encoders for encoder output pulse Select an encoder used the encoder output pulses which the servo amplifier outputs. 0: Servo motor encoder 1: Load-side encoder When "_10_" is set to this parameter, [AL. 37 Parameter error] will occur. This is only for the fully closed loop system. If "1" is set other than in the fully closed loop system, [AL. 37 Parameter error] will occur.	0h	<input type="radio"/>	<input type="radio"/>	<input type="radio"/>												
x___	For manufacturer setting	0h	<input type="radio"/>	<input type="radio"/>	<input type="radio"/>												
PC20 *SNO Station No. setting		Specify a station No. of the servo amplifier for RS-422 and USB communication. Always set one station to one axis of the servo amplifier. Setting one station number to two or more stations will disable a normal communication. Setting range: 0 to 31	0 [Station]	<input type="radio"/>	<input type="radio"/>	<input type="radio"/>											

7. PARAMETERS

No./ symbol/name	Setting digit	Function	Initial value [unit]	Control mode		
				CP/BCD	CL	PS
PC21	Select the details of RS-422 communication function.					
*SOP	___x	For manufacturer setting	0h			
RS-422 communication function selection	__x_	RS-422 communication baud rate selection When using the parameter unit, set "1 ___" in [Pr. PF34]. 0: 9600 [bps] 1: 19200 [bps] 2: 38400 [bps] 3: 57600 [bps] 4: 115200 [bps]	0h	○	○	○
	_x__	RS-422 communication response delay time selection 0: Disabled 1: Enabled (responding after 800 μs or longer delay time)	0h	○	○	○
	x___	For manufacturer setting	0h			
	PC22	___x	For manufacturer setting	0h		
*COP1 Function selection C-1	__x_		0h			
	_x__		0h			
	x___	Encoder cable communication method selection Select the encoder cable communication method. 0: Two-wire type 1: Four-wire type When using an encoder of A/B/Z-phase differential output method, set "0". If the setting is incorrect, [AL. 16 Encoder initial communication error 1] or [AL. 20 Encoder normal communication error 1] occurs. For MR-J4-03A6-RJ servo amplifiers, this digit cannot be used other than the initial value. Also, it does not comply with encoders of A/B/Z-phase differential output method.	0h	○	○	○
PC24	___x	In-position range unit selection Select a unit of in-position range. 0: Command unit 1: Servo motor encoder pulse unit	0h	○	○	○
*COP3 Function selection C-3	__x_	For manufacturer setting	0h			
	_x__		0h			
	x___	Error excessive alarm level unit selection Select a setting unit of the error excessive alarm level set in [Pr. PC43]. 0: Per 1 rev or 1 mm 1: Per 0.1 rev or 0.1 mm 2: Per 0.01 rev or 0.01 mm 3: Per 0.001 rev or 0.001 mm	0h	○	○	○
PC26	___x	[AL. 99 Stroke limit warning] selection Enable or disable [AL. 99 Stroke limit warning]. 0: Enabled 1: Disabled	0h	○	○	○
*COP5 Function selection C-5	__x_	For manufacturer setting	0h			
	_x__		0h			
	x___		0h			

7. PARAMETERS

No./ symbol/name	Setting digit	Function	Initial value [unit]	Control mode		
				CP/BCD	CL	PS
PC27 *COP6 Function selection C-6	___x	[AL. 10 Undervoltage] detection method selection Set this parameter when [AL. 10 Undervoltage] occurs due to distorted power supply voltage waveform while using FR-RC-(H) or FR-CV-(H). 0: [AL. 10] not occurrence 1: [AL. 10] occurrence This digit is not available with MR-J4-03A6-RJ servo amplifiers.	0h	<input type="radio"/>	<input type="radio"/>	<input type="radio"/>
	__x_	Main circuit power supply selection Select a voltage to be connected to the main circuit power supply with an MR-J4-03A6-RJ servo amplifier. 0: 48 V DC 1: 24 V DC When using 24 V DC for the main circuit power supply, set "1" to this digit. This digit is not available with MR-J4-_A_-RJ 100 W or more servo amplifiers. The characteristics of the servo motor vary depending on whether 48 V DC or 24 V DC is used. For details, refer to "Servo Motor Instruction Manual (Vol. 3)".	0h	<input type="radio"/>	<input type="radio"/>	<input type="radio"/>
	_x__	Undervoltage alarm selection Select the alarm and warning that occurs when the bus voltage drops to the undervoltage alarm level. 0: [AL. 10] regardless of servo motor speed 1: [AL. E9] at servo motor speed 50 r/min (50 mm/s) or less, [AL. 10] at over 50 r/min (50 mm/s)	0h	<input type="radio"/>	<input type="radio"/>	<input type="radio"/>
	x___	For manufacturer setting	0h	<input type="checkbox"/>	<input type="checkbox"/>	<input type="checkbox"/>
PC28 *COP7 Function selection C-7	___x	For manufacturer setting	0h	<input type="checkbox"/>	<input type="checkbox"/>	<input type="checkbox"/>
	__x_		0h	<input type="checkbox"/>	<input type="checkbox"/>	<input type="checkbox"/>
	_x__		0h	<input type="checkbox"/>	<input type="checkbox"/>	<input type="checkbox"/>
	x___	Linear scale multipoint Z-phase input function selection When two or more reference marks exist during the full stroke of the linear encoder, set "1". 0: Disabled 1: Enabled This parameter setting is used by servo amplifiers with software version A5 or later. This digit is not available with MR-J4-03A6-RJ servo amplifiers.	0h	<input type="radio"/>	<input type="radio"/>	<input type="checkbox"/>
PC30 STA2 Home position return acceleration time constant		This parameter is used when a home position return is executed with the program method. Set the acceleration time constant at the home position return. Set an acceleration time from 0 r/min or 0 mm/s to the rated speed. Additionally, when 20000 ms or more value is set, it will be clamped to 20000 ms. Setting range: 0 to 50000	0 [ms]	<input type="checkbox"/>	<input type="radio"/>	<input type="checkbox"/>
PC30 STA2 Acceleration time constant 2		Set an second acceleration time constant for the automatic operation of the indexer method. Set an acceleration time from 0 r/min to the rated speed. Additionally, when 20000 ms or more value is set, it will be clamped to 20000 ms. Setting range: 0 to 50000	0 [ms]	<input type="checkbox"/>	<input type="checkbox"/>	<input type="radio"/>
PC31 STB2 Home position return deceleration time constant		This parameter is used when a home position return is executed with the program method. Set the deceleration time constant at the home position return. Set a deceleration time from the rated speed to 0 r/min or 0 mm/s. Additionally, when 20000 ms or more value is set, it will be clamped to 20000 ms. Setting range: 0 to 50000	0 [ms]	<input type="checkbox"/>	<input type="radio"/>	<input type="checkbox"/>

7. PARAMETERS

No./ symbol/name	Setting digit	Function	Initial value [unit]	Control mode		
				CP/BCD	CL	PS
PC31 STB2 Deceleration time constant 2		<p>Set an second deceleration time constant for the automatic operation of the indexer method.</p> <p>Set a deceleration time from the rated speed to 0 r/min.</p> <p>Additionally, when 20000 ms or more value is set, it will be clamped to 20000 ms.</p> <p>Setting range: 0 to 50000</p>	0 [ms]			○
PC35 TL2 Internal torque limit 2/internal thrust limit 2		<p>Set the parameter on the assumption that the maximum torque or thrust is 100.0 %. The parameter is set for limiting the torque of the servo motor or the thrust of the linear servo motor.</p> <p>No torque or thrust is generated when this parameter is set to "0.0".</p> <p>When TL1 (Internal torque limit selection) is turned on, Internal torque limit 1 and Internal torque limit 2 are compared and the lower value will be enabled.</p> <p>Set the parameter referring to section 3.6.1 (5) of "MR-J4-_A_(-RJ) Servo Amplifier Instruction Manual" and section 11.5.3 (6) of this Instruction Manual.</p> <p>Setting range: 0.0 to 100.0</p>	100.0 [%]	○	○	○

7. PARAMETERS

No./ symbol/name	Setting digit	Function	Initial value [unit]	Control mode		
				CP/BCD	CL	PS
PC36 *DMD Status display selection	-- x x	Status display selection at power-on Select a status display shown at power-on. 00: Cumulative feedback pulse 01: Servo motor speed/linear servo motor speed 02: Droop pulses 03: Cumulative command pulses 04: Command pulse frequency 05: Analog speed command voltage (not used for the positioning mode) 06: Analog torque limit voltage 07: Regenerative load ratio 08: Effective load ratio 09: Peak load ratio 0A: Instantaneous torque/instantaneous thrust 0B: Position within one-revolution/virtual position within one-revolution (1 pulse unit) 0C: Position within one-revolution/virtual position within one-revolution (1000 pulses unit) 0D: ABS counter/virtual ABS counter 0E: Load to motor inertia ratio/load to motor mass ratio 0F: Bus voltage 10: Internal temperature of encoder 11: Settling time 12: Oscillation detection frequency 13: Number of tough drives 14: Unit power consumption (1 W unit) 15: Unit power consumption (1 kW unit) 16: Unit total power consumption (1 Wh unit) 17: Unit total power consumption (100 kWh unit) 18: Load-side cumulative feedback pulses (Note 1, 3) 19: Load-side droop pulses (Note 1, 3) 1A: Load-side encoder information 1 (1 pulse unit) (Note 1, 3) 1B: Load-side encoder information 1 (100000 pulses unit) (Note 1, 3) 1C: Load-side encoder ABS counter (Note 1, 3) 1D: Z-phase counter (1 pulse unit) (Note 2, 3) 1E: Z-phase counter (100000 pulses unit) (Note 2, 3) 1F: Electrical angle (1 pulse unit) (Note 2, 3) 20: Electrical angle (100000 pulses unit) (Note 2, 3) 21: Current position 22: Command position 23: Command remaining distance 24: Point table No./Program No./Station position No. 25: Step No. 26: Override voltage 27: Override level 28: Cam axis one cycle current value 29: Cam standard position 2A: Cam axis feed current value 2B: Cam No. in execution 2C: Cam stroke amount in execution 2D: Main axis current value 2E: Main axis one cycle current value Note 1. Setting "18 to 1C" will trigger [AL. 37] in the mode other than the fully closed loop control mode. 2. Setting 1D to 20 will trigger [AL. 37] in the mode other than the linear servo motor control mode. 3. This is not available with the MR-J4-03A6-RJ servo amplifier.	00h	○	○	○

7. PARAMETERS

No./ symbol/name	Setting digit	Function	Initial value [unit]	Control mode										
				CP/BCD	CL	PS								
PC36 *DMD Status display selection	_ x _ _	Status display at power-on in corresponding control mode 0: Depends on the control mode <table border="1" data-bbox="438 459 1173 593"> <thead> <tr> <th>Control mode</th> <th>Status display at power-on</th> </tr> </thead> <tbody> <tr> <td>Positioning (point table method)</td> <td>Current position</td> </tr> <tr> <td>Positioning (program method)</td> <td>Current position</td> </tr> <tr> <td>Positioning (indexer method)</td> <td>Cumulative feedback pulses</td> </tr> </tbody> </table> 1: Depends on the last two digit setting of the parameter	Control mode	Status display at power-on	Positioning (point table method)	Current position	Positioning (program method)	Current position	Positioning (indexer method)	Cumulative feedback pulses	0h	<input type="radio"/>	<input type="radio"/>	<input type="radio"/>
	Control mode	Status display at power-on												
Positioning (point table method)	Current position													
Positioning (program method)	Current position													
Positioning (indexer method)	Cumulative feedback pulses													
	x _ _ _	For manufacturer setting	0h	<input type="radio"/>	<input type="radio"/>	<input type="radio"/>								
PC37 VCO Analog override Offset	/	Set an offset voltage of VC (Override input). This will be automatic setting by executing VC automatic offset. Setting range: -9999 to 9999	0 [mV]	<input type="radio"/>	<input type="radio"/>	<input type="radio"/>								
PC38 TPO Analog torque limit offset	/	Set the offset voltage of TLA (Analog torque limit). Setting range: -9999 to 9999	0 [mV]	<input type="radio"/>	<input type="radio"/>	<input type="radio"/>								
PC39 MO1 Analog monitor 1 offset	/	Set the offset voltage of MO1 (Analog monitor 1). Setting range: -9999 to 9999	0 [mV]	<input type="radio"/>	<input type="radio"/>	<input type="radio"/>								
PC40 MO2 Analog monitor 2 offset	/	Set the offset voltage of MO2 (Analog monitor 2). Setting range: -9999 to 9999	0 [mV]	<input type="radio"/>	<input type="radio"/>	<input type="radio"/>								
PC43 ERZ Error excessive alarm level	/	Set an error excessive alarm level. You can change the setting unit with "Error excessive alarm level" in [Pr. PC24]. Set this per rev. for rotary servo motors and direct drive motors. Set this per mm for linear servo motors. Setting "0" will be "3 rev" for rotary servo motors and direct drive motors and "100 mm" for linear servo motors. Setting over 200 rev will be clamped with 200 rev. Setting range: 0 to 1000	0 [rev]/ [mm]	<input type="radio"/>	<input type="radio"/>	<input type="radio"/>								
PC44 *COP9 Function selection C-9	_ _ _ x	For manufacturer setting	0h	<input type="radio"/>	<input type="radio"/>	<input type="radio"/>								
	_ _ x _		0h	<input type="radio"/>	<input type="radio"/>	<input type="radio"/>								
	_ x _ _		0h	<input type="radio"/>	<input type="radio"/>	<input type="radio"/>								
	x _ _ _	Load-side encoder cable communication method selection Select an encoder cable to be connected to the CN2L connector of MR-J4- _A_-RJ. 0: Two-wire type 1: Four-wire type When using an encoder of A/B/Z-phase differential output method, set "0". Incorrect setting will trigger [AL. 70] and [AL. 71]. This digit is not available with MR-J4-03A6-RJ servo amplifiers.	0h	<input type="radio"/>	<input type="radio"/>	<input type="radio"/>								

7. PARAMETERS

No./ symbol/name	Setting digit	Function	Initial value [unit]	Control mode		
				CP/BCD	CL	PS
PC45 *COPA Function selection C-A	___x	Encoder pulse count polarity selection Select a polarity of the linear encoder or load-side encoder. 0: Encoder pulse increasing direction in the servo motor CCW or positive direction 1: Encoder pulse decreasing direction in the servo motor CCW or positive direction This digit is not available with MR-J4-03A6-RJ servo amplifiers.	0h	<input type="radio"/>	<input type="radio"/>	<input type="radio"/>
	__x_	For manufacturer setting	0h	<input type="radio"/>	<input type="radio"/>	<input type="radio"/>
	_x__	Selection of A/B/Z-phase input interface encoder Z-phase connection judgment function Select the non-signal detection status for the pulse train signal from the A/B/Z-phase input interface encoder used as a linear encoder or load-side encoder. This function is enabled only when you use an A/B/Z-phase input interface encoder. This digit is not available with MR-J4-03A6-RJ servo amplifiers.	0h	<input type="radio"/>	<input type="radio"/>	<input type="radio"/>
	x___	For manufacturer setting	0h	<input type="radio"/>	<input type="radio"/>	<input type="radio"/>
PC51 RSBR Forced stop deceleration time constant	x___	Set a deceleration time constant when you use the forced stop deceleration function. Set the time per ms from the rated speed to 0 r/min or 0 mm/s. Setting "0" will be 100 ms.	100 [ms]	<input type="radio"/>	<input type="radio"/>	<input type="radio"/>
		<p>[Precautions]</p> <ul style="list-style-type: none"> • If the servo motor torque or linear servo motor thrust is saturated at the maximum value during forced stop deceleration because the set time is too short, the time to stop will be longer than the set time constant. • [AL. 50 Overload alarm 1] or [AL. 51 Overload alarm 2] may occur during forced stop deceleration, depending on the set value. • After an alarm that leads to a forced stop deceleration, if an alarm that does not lead to a forced stop deceleration occurs or if the control circuit power supply is cut, dynamic braking will start regardless of the deceleration time constant setting. <p>Setting range: 0 to 20000</p>				

7. PARAMETERS

No./ symbol/name	Setting digit	Function	Initial value [unit]	Control mode		
				CP/BCD	CL	PS
PC54 RSUP1 Vertical axis freefall prevention compensation amount		<p>Set the compensation amount of the vertical axis freefall prevention function. Set it per servo motor rotation amount or linear servo motor travel distance. When setting a positive value, the servo motor/linear servo motor will pull in the direction of the servo motor rotation direction/linear servo motor travel direction at positioning address increasing with the servo motor rotation amount/linear servo motor travel distance unit. When setting a negative value, the servo motor/linear servo motor will pull in the direction of the servo motor rotation direction/linear servo motor travel direction at positioning address decreasing with the servo motor rotation amount/linear servo motor travel distance unit.</p> <p>For example, if a positive compensation amount is set when the [Pr. PA14 Rotation direction selection/travel direction selection] setting is "1", the axis will be pulled to the CW direction.</p> <p>The vertical axis freefall prevention function is performed when all of the following conditions are met.</p> <ol style="list-style-type: none"> 1) The value of the parameter is other than "0". 2) The forced stop deceleration function is enabled. 3) Alarm occurs or EM2 turns off when the (linear) servo motor speed is zero speed or less. 4) MBR (Electromagnetic brake interlock) was enabled in [Pr. PD23] to [Pr. PD26], [Pr. PD28], and [Pr. PD47], and the base circuit shut-off delay time was set in [Pr. PC16]. <p>Setting range: -25000 to 25000</p>	0 [0.0001 rev]/ [0.01 mm]	<input type="radio"/>	<input type="radio"/>	<input type="radio"/>
PC60 *COPD Function selection C-D	___x	<p>Motor-less operation selection Set the motor-less operation. This is not used in the linear servo motor control mode, fully closed loop control, and DD motor control mode. 0: Disabled 1: Enabled</p>	0h	<input type="radio"/>	<input type="radio"/>	<input type="radio"/>
	__x_	<p>High-resolution analog input selection Select the resolution of VC (Analog override). When you change parameters, perform offset adjustment with [Pr. PC37 Analog override offset]. The offset adjustment can be performed by executing VC automatic offset. Setting "1" while using a servo amplifier other than MR-J4-_A_-RJ, MR-J4-_A_-RU, and MR-J4-_A_-RZ will trigger [AL. 37]. 0: Disabled 1: Enabled This digit is available with servo amplifiers manufactured in November 2014 or later. This digit is not available with MR-J4-03A6-RJ servo amplifiers.</p>	0h	<input type="radio"/>	<input type="radio"/>	<input type="radio"/>
	_x__	For manufacturer setting	0h	<input type="radio"/>	<input type="radio"/>	<input type="radio"/>
	x___	<p>[AL. 9B Error excessive warning] selection 0: [AL. 9B Error excessive warning] is disabled. 1: [AL. 9B Error excessive warning] is enabled. This parameter is available with servo amplifiers with software version B4 or later.</p>	0h	<input type="radio"/>	<input type="radio"/>	<input type="radio"/>

7. PARAMETERS

No./ symbol/name	Setting digit	Function	Initial value [unit]	Control mode		
				CP/BCD	CL	PS
PC66 LPSPL Mark detection range + (lower three digits)		Set the upper limit of the mark detection. Upper and lower are a set. When the roll feed display is enabled, set this value with the travel distance from the starting position. Setting address: <div style="text-align: center;"> </div>	0 Refer to Function column for unit.	○	○	
PC67 LPSPH Mark detection range + (upper three digits)						
PC68 LPSNL Mark detection range - (lower three digits)		Set the lower limit of the mark detection. Upper and lower are a set. When the roll feed display is enabled, set this value with the travel distance from the starting position. Setting address: <div style="text-align: center;"> </div>	0 Refer to Function column for unit.	○	○	
PC69 LPSNH Mark detection range - (upper three digits)						

7. PARAMETERS

No./ symbol/name	Setting digit	Function	Initial value [unit]	Control mode		
				CP/BCD	CF	PS
PC73 ERW Error excessive warning level		<p>Set an error excessive warning level.</p> <p>To enable the parameter, set "[AL. 9B Error excessive warning] selection" to "Enabled (1 _ _ _)" in [Pr. PC60].</p> <p>The setting unit can be changed with "Error excessive alarm/error excessive warning level unit selection" in [Pr. PC24].</p> <p>Set this per rev. for rotary servo motors and direct drive motors. When "0" is set, 1 rev will be applied. Setting over 200 rev will be clamped to 200 rev. Set this per mm for linear servo motors. Setting "0" will be 50 mm.</p> <p>When an error reaches the set value, [AL. 9B Error excessive warning] will occur. When the error decreases lower than the set value, the warning will be canceled automatically. The minimum pulse width of the warning signal is 100 [ms].</p> <p>Set as follows: [Pr. PC73 Error excessive warning level] < [Pr. PC43 Error excessive alarm level] When you set as [Pr. PC73 Error excessive warning level] ≥ [Pr. PC43 Error excessive alarm level], [AL. 52 Error excessive] will occur earlier than the warning.</p> <p>This parameter setting is available with servo amplifiers with software version B4 or later.</p> <p>Setting range: 0 to 1000</p>	0 [rev]/ [mm]	<input type="radio"/>	<input type="radio"/>	<input type="radio"/>

7. PARAMETERS

7.2.4 I/O setting parameters ([Pr. PD__])

No./ symbol/name	Setting digit	Function	Initial value [unit]	Control mode			
				CP/BCD	CL	PS	
PD01 *DIA1 Input signal automatic on selection 1	Select input devices to turn on them automatically.		0h				
	___x (HEX)	___x (BIN): For manufacturer setting					
		__x_ (BIN): For manufacturer setting					
		_x__ (BIN): SON (Servo-on) 0: Disabled (Use for an external input signal.) 1: Enabled (automatic on)			○	○	○
		x___ (BIN): For manufacturer setting					
	__x_ (HEX)	___x (BIN): PC (Proportional control) 0: Disabled (Use for an external input signal.) 1: Enabled (automatic on)	0h	○	○	○	
		__x_ (BIN): TL (External torque/external thrust limit selection) 0: Disabled (Use for an external input signal.) 1: Enabled (automatic on)		○	○	○	
		_x___ (BIN): For manufacturer setting					
		x___ (BIN): For manufacturer setting					
	_x__ (HEX)	___x (BIN): For manufacturer setting	0h				
		__x_ (BIN): For manufacturer setting					
		_x__ (BIN): LSP (Forward rotation stroke end) 0: Disabled (Use for an external input signal.) 1: Enabled (automatic on)		○	○	○	
		x___ (BIN): LSN (Reverse rotation stroke end) 0: Disabled (Use for an external input signal.) 1: Enabled (automatic on)	○	○	○		
	x___ (HEX)	___x (BIN): EM2 (Forced stop 2)/EM1 (Forced stop 1) 0: Disabled (Use for an external input signal.) 1: Enabled (automatic on)	0h	○	○	○	
		__x_ (BIN): For manufacturer setting					
		_x__ (BIN): For manufacturer setting					
	x___ (BIN): For manufacturer setting						

7. PARAMETERS

No./ symbol/name	Setting digit	Function	Initial value [unit]																																																										
			CP/BCD	CL	PS																																																								
PD01 *DIA1 Input signal automatic on selection 1		<p>Convert the setting value into hexadecimal as follows.</p> <table border="1"> <thead> <tr> <th rowspan="2">Signal name</th> <th colspan="2">Initial value</th> </tr> <tr> <th>BIN</th> <th>HEX</th> </tr> </thead> <tbody> <tr> <td></td> <td>0</td> <td rowspan="4">0</td> </tr> <tr> <td></td> <td>0</td> </tr> <tr> <td>SON (Servo-on)</td> <td>0</td> </tr> <tr> <td></td> <td>0</td> </tr> </tbody> </table> <table border="1"> <thead> <tr> <th rowspan="2">Signal name</th> <th colspan="2">Initial value</th> </tr> <tr> <th>BIN</th> <th>HEX</th> </tr> </thead> <tbody> <tr> <td>PC (Proportional control)</td> <td>0</td> <td rowspan="4">0</td> </tr> <tr> <td>TL (External torque/external thrust limit selection)</td> <td>0</td> </tr> <tr> <td></td> <td>0</td> </tr> <tr> <td></td> <td>0</td> </tr> </tbody> </table> <table border="1"> <thead> <tr> <th rowspan="2">Signal name</th> <th colspan="2">Initial value</th> </tr> <tr> <th>BIN</th> <th>HEX</th> </tr> </thead> <tbody> <tr> <td></td> <td>0</td> <td rowspan="4">0</td> </tr> <tr> <td></td> <td>0</td> </tr> <tr> <td>LSP (Forward rotation stroke end)</td> <td>0</td> </tr> <tr> <td>LSN (Reverse rotation stroke end)</td> <td>0</td> </tr> </tbody> </table> <table border="1"> <thead> <tr> <th rowspan="2">Signal name</th> <th colspan="2">Initial value</th> </tr> <tr> <th>BIN</th> <th>HEX</th> </tr> </thead> <tbody> <tr> <td>EM2 (Forced stop 2)/EM1 (Forced stop 1)</td> <td>0</td> <td rowspan="4">0</td> </tr> <tr> <td></td> <td>0</td> </tr> <tr> <td></td> <td>0</td> </tr> <tr> <td></td> <td>0</td> </tr> </tbody> </table> <p>BIN 0: Use for an external input signal. BIN 1: Automatic on</p>	Signal name	Initial value		BIN	HEX		0	0		0	SON (Servo-on)	0		0	Signal name	Initial value		BIN	HEX	PC (Proportional control)	0	0	TL (External torque/external thrust limit selection)	0		0		0	Signal name	Initial value		BIN	HEX		0	0		0	LSP (Forward rotation stroke end)	0	LSN (Reverse rotation stroke end)	0	Signal name	Initial value		BIN	HEX	EM2 (Forced stop 2)/EM1 (Forced stop 1)	0	0		0		0		0			
Signal name	Initial value																																																												
	BIN	HEX																																																											
	0	0																																																											
	0																																																												
SON (Servo-on)	0																																																												
	0																																																												
Signal name	Initial value																																																												
	BIN	HEX																																																											
PC (Proportional control)	0	0																																																											
TL (External torque/external thrust limit selection)	0																																																												
	0																																																												
	0																																																												
Signal name	Initial value																																																												
	BIN	HEX																																																											
	0	0																																																											
	0																																																												
LSP (Forward rotation stroke end)	0																																																												
LSN (Reverse rotation stroke end)	0																																																												
Signal name	Initial value																																																												
	BIN	HEX																																																											
EM2 (Forced stop 2)/EM1 (Forced stop 1)	0	0																																																											
	0																																																												
	0																																																												
	0																																																												

7. PARAMETERS

No./ symbol/name	Setting digit	Function	Initial value [unit]	Control mode				
				CP/BCD	CL	PS		
PD04	Any input device can be assigned to the CN1-15 pin.							
*D11H	__ x x	Not used with the positioning mode.	02h					
Input device selection 1H	x x __	Positioning mode - Device selection Refer to table 7.10 for settings.	02h	○	○	○		

Table 7.10 Selectable input devices

Setting value	Input device (Note 1)		
	CP/BCD	CL	PS
0 2 __	SON	SON	SON
0 3 __	RES	RES	RES
0 4 __	PC	PC	PC
0 5 __	TL	TL	TL
0 6 __	CR	CR	CR
0 7 __	ST1	ST1	ST1
0 8 __	ST2	ST2	
0 9 __	TL1	TL1	TL1
0 A __	LSP	LSP	LSP
0 B __	LSN	LSN	LSN
0 D __	CDP	CDP	CDP
0 F __ (Note 2)	MECR	MECR	
1 2 __	MSD	MSD	
1 E __	CLTC (Note 3)	CLTC (Note 3)	
1 F __	CPCD (Note 3)	CPCD (Note 3)	
2 0 __	MD0	MD0	MD0
2 1 __	CAMC (Note 3)	CAMC (Note 3)	MD1
2 3 __	TCH		
2 4 __	TP0	TP0	
2 5 __	TP1	TP1	
2 6 __	OVR	OVR	
2 7 __	TSTP	TSTP	
2 9 __	CI0 (Note 3)	CI0 (Note 3)	
2 A __	CI1 (Note 3)	CI1 (Note 3)	
2 B __	DOG	DOG	SIG
2 C __	SPD1 (Note 3)		
2 D __	SPD2 (Note 3)		
2 E __	SPD3 (Note 3)		
2 F __	SPD4 (Note 3)		
3 0 __		LPS	
3 1 __	CI2 (Note 3)	CI2 (Note 3)	RT
3 2 __			RTCDP
3 4 __		PI1	OV0
3 5 __		PI2	OV1
3 6 __		PI3	OV2
3 7 __	CI3 (Note 3)	CI3 (Note 3)	OV3
3 8 __	DI0	DI0	DI0
3 9 __	DI1	DI1	DI1
3 A __	DI2	DI2	DI2
3 B __	DI3	DI3	DI3
3 C __	DI4	DI4	DI4
3 D __	DI5	DI5	DI5
3 E __	DI6	DI6	DI6
3 F __	DI7	DI7	DI7

- Note 1. CP: Positioning mode (point table method)
 BCD: Positioning mode (point table method in the BCD input positioning operation)
 This method is available only when the MR-D01 unit is connected. Refer to chapter 12 for details.
 CL: Positioning mode (program method)
 PS: Positioning mode (indexer method)
 The diagonal lines indicate manufacturer settings. Never change the setting.
2. It cannot be set with MR-J4-03A6-RJ servo amplifiers.
3. This is available with servo amplifiers with software version B7 or later.

7. PARAMETERS

No./ symbol/name	Setting digit	Function	Initial value [unit]	Control mode		
				CP/BCD	CL	PS
PD06		Any input device can be assigned to the CN1-16 pin.				
*DI2H	__ x x	Not used with the positioning mode.	21h	<input type="checkbox"/>	<input type="checkbox"/>	<input type="checkbox"/>
Input device selection 2H	x x __	Positioning mode - Device selection Refer to table 7.10 in [Pr. PD04] for settings.	20h	<input type="checkbox"/>	<input type="checkbox"/>	<input type="checkbox"/>
PD08		Any input device can be assigned to the CN1-17 pin.				
*DI3H	__ x x	Not used with the positioning mode.	07h	<input type="checkbox"/>	<input type="checkbox"/>	<input type="checkbox"/>
Input device selection 3H	x x __	Positioning mode - Device selection Refer to table 7.10 in [Pr. PD04] for settings.	07h	<input type="checkbox"/>	<input type="checkbox"/>	<input type="checkbox"/>
PD10		Any input device can be assigned to the CN1-18 pin.				
*DI4H	__ x x	Not used with the positioning mode.	08h	<input type="checkbox"/>	<input type="checkbox"/>	<input type="checkbox"/>
Input device selection 4H	x x __	Positioning mode - Device selection Refer to table 7.10 in [Pr. PD04] for settings.	08h	<input type="checkbox"/>	<input type="checkbox"/>	<input type="checkbox"/>
PD12		Any input device can be assigned to the CN1-19 pin.				
*DI5H	__ x x	Not used with the positioning mode.	03h	<input type="checkbox"/>	<input type="checkbox"/>	<input type="checkbox"/>
Input device selection 5H	x x __	Positioning mode - Device selection Refer to table 7.10 in [Pr. PD04] for settings.	38h	<input type="checkbox"/>	<input type="checkbox"/>	<input type="checkbox"/>
PD14		Any input device can be assigned to the CN1-41 pin.				
*DI6H	__ x x	Not used with the positioning mode.	20h	<input type="checkbox"/>	<input type="checkbox"/>	<input type="checkbox"/>
Input device selection 6H	x x __	Positioning mode - Device selection Refer to table 7.10 in [Pr. PD04] for settings.	39h	<input type="checkbox"/>	<input type="checkbox"/>	<input type="checkbox"/>
PD18		Any input device can be assigned to the CN1-43 pin.				
*DI8H	__ x x	Not used with the positioning mode.	00h	<input type="checkbox"/>	<input type="checkbox"/>	<input type="checkbox"/>
Input device selection 8H	x x __	Positioning mode - Device selection Refer to table 7.10 in [Pr. PD04] for settings.	0Ah	<input type="checkbox"/>	<input type="checkbox"/>	<input type="checkbox"/>
PD20		Any input device can be assigned to the CN1-44 pin.				
*DI9H	__ x x	Not used with the positioning mode.	00h	<input type="checkbox"/>	<input type="checkbox"/>	<input type="checkbox"/>
Input device selection 9H	x x __	Positioning mode - Device selection Refer to table 7.10 in [Pr. PD04] for settings.	0Bh	<input type="checkbox"/>	<input type="checkbox"/>	<input type="checkbox"/>
PD22		Any input device can be assigned to the CN1-45 pin.				
*DI10H	__ x x	Not used with the positioning mode.	23h	<input type="checkbox"/>	<input type="checkbox"/>	<input type="checkbox"/>
Input device selection 10H	x x __	Positioning mode - Device selection Refer to table 7.10 in [Pr. PD04] for settings.	2Bh	<input type="checkbox"/>	<input type="checkbox"/>	<input type="checkbox"/>

7. PARAMETERS

No./ symbol/name	Setting digit	Function	Initial value [unit]	Control mode																																																																																																																																																	
				CP/BCD	CL	PS																																																																																																																																															
PD23 *DO1 Output device selection 1	__ x x	Device selection Any output device can be assigned to the CN1-22 pin. Refer to table 7.11 for settings.	04h	○	○	○																																																																																																																																															
	_ x _ _	For manufacturer setting	0h	▤	▤	▤																																																																																																																																															
	x _ _ _		0h	▤	▤	▤																																																																																																																																															
Table 7.11 Selectable output devices																																																																																																																																																					
<table border="1" style="width: 100%; border-collapse: collapse;"> <thead> <tr> <th rowspan="2">Setting value</th> <th colspan="3">Output device (Note 1)</th> </tr> <tr> <th>CP/BCD</th> <th>CL</th> <th>PS</th> </tr> </thead> <tbody> <tr><td>__ 0 0</td><td>Always off</td><td>Always off</td><td>Always off</td></tr> <tr><td>__ 0 2</td><td>RD</td><td>RD</td><td>RD</td></tr> <tr><td>__ 0 3</td><td>ALM</td><td>ALM</td><td>ALM</td></tr> <tr><td>__ 0 4</td><td>INP</td><td>INP</td><td>INP</td></tr> <tr><td>__ 0 5</td><td>MBR</td><td>MBR</td><td>MBR</td></tr> <tr><td>__ 0 6 (Note 2)</td><td>DB</td><td>DB</td><td>DB</td></tr> <tr><td>__ 0 7</td><td>TLC</td><td>TLC</td><td>TLC</td></tr> <tr><td>__ 0 8</td><td>WNG</td><td>WNG</td><td>WNG</td></tr> <tr><td>__ 0 9</td><td>BWNG</td><td>BWNG</td><td>BWNG</td></tr> <tr><td>__ 0 A</td><td>SA</td><td>SA</td><td>Always off</td></tr> <tr><td>__ 0 B</td><td>Always off</td><td>Always off</td><td>Always off</td></tr> <tr><td>__ 0 C</td><td>ZSP</td><td>ZSP</td><td>ZSP</td></tr> <tr><td>__ 0 D (Note 2)</td><td>MTTR</td><td>MTTR</td><td>MTTR</td></tr> <tr><td>__ 0 F</td><td>CDPS</td><td>CDPS</td><td>CDPS</td></tr> <tr><td>__ 1 0 (Note 2)</td><td>CLDS</td><td>CLDS</td><td>CLDS</td></tr> <tr><td>__ 1 1</td><td>ABSV</td><td>ABSV</td><td>ABSV</td></tr> <tr><td>__ 1 F (Note 2)</td><td>CPCC (Note 4)</td><td>CPCC (Note 4)</td><td>▤</td></tr> <tr><td>__ 2 3</td><td>CPO</td><td>CPO</td><td>CPO</td></tr> <tr><td>__ 2 4</td><td>ZP</td><td>ZP</td><td>ZP</td></tr> <tr><td>__ 2 5</td><td>POT</td><td>POT</td><td>Always off</td></tr> <tr><td>__ 2 6</td><td>PUS</td><td>PUS</td><td>Always off</td></tr> <tr><td>__ 2 7</td><td>MEND</td><td>MEND</td><td>MEND</td></tr> <tr><td>__ 2 9 (Note 2)</td><td>CLTS (Note 4)</td><td>CLTS (Note 4)</td><td>▤</td></tr> <tr><td>__ 2 B (Note 2)</td><td>CLTSM (Note 4)</td><td>CLTSM (Note 4)</td><td>▤</td></tr> <tr><td>__ 2 C</td><td>PED</td><td>PED</td><td>▤</td></tr> <tr><td>__ 2 D</td><td>▤</td><td>SOUT</td><td>▤</td></tr> <tr><td>__ 2 E</td><td>▤</td><td>OUT1</td><td>▤</td></tr> <tr><td>__ 2 F</td><td>▤</td><td>OUT2</td><td>▤</td></tr> <tr><td>__ 3 0</td><td>▤</td><td>OUT3</td><td>▤</td></tr> <tr><td>__ 3 1</td><td>ALMWNG</td><td>ALMWNG</td><td>ALMWNG</td></tr> <tr><td>__ 3 2</td><td>BW9F</td><td>BW9F</td><td>BW9F</td></tr> <tr><td>__ 3 3</td><td>MSDH</td><td>MSDH</td><td>▤</td></tr> <tr><td>__ 3 4</td><td>MSDL</td><td>MSDL</td><td>▤</td></tr> <tr><td>__ 3 7 (Note 2)</td><td>CAMS (Note 4)</td><td>CAMS (Note 4)</td><td>▤</td></tr> </tbody> </table>							Setting value	Output device (Note 1)			CP/BCD	CL	PS	__ 0 0	Always off	Always off	Always off	__ 0 2	RD	RD	RD	__ 0 3	ALM	ALM	ALM	__ 0 4	INP	INP	INP	__ 0 5	MBR	MBR	MBR	__ 0 6 (Note 2)	DB	DB	DB	__ 0 7	TLC	TLC	TLC	__ 0 8	WNG	WNG	WNG	__ 0 9	BWNG	BWNG	BWNG	__ 0 A	SA	SA	Always off	__ 0 B	Always off	Always off	Always off	__ 0 C	ZSP	ZSP	ZSP	__ 0 D (Note 2)	MTTR	MTTR	MTTR	__ 0 F	CDPS	CDPS	CDPS	__ 1 0 (Note 2)	CLDS	CLDS	CLDS	__ 1 1	ABSV	ABSV	ABSV	__ 1 F (Note 2)	CPCC (Note 4)	CPCC (Note 4)	▤	__ 2 3	CPO	CPO	CPO	__ 2 4	ZP	ZP	ZP	__ 2 5	POT	POT	Always off	__ 2 6	PUS	PUS	Always off	__ 2 7	MEND	MEND	MEND	__ 2 9 (Note 2)	CLTS (Note 4)	CLTS (Note 4)	▤	__ 2 B (Note 2)	CLTSM (Note 4)	CLTSM (Note 4)	▤	__ 2 C	PED	PED	▤	__ 2 D	▤	SOUT	▤	__ 2 E	▤	OUT1	▤	__ 2 F	▤	OUT2	▤	__ 3 0	▤	OUT3	▤	__ 3 1	ALMWNG	ALMWNG	ALMWNG	__ 3 2	BW9F	BW9F	BW9F	__ 3 3	MSDH	MSDH	▤	__ 3 4	MSDL	MSDL	▤	__ 3 7 (Note 2)	CAMS (Note 4)	CAMS (Note 4)	▤
Setting value	Output device (Note 1)																																																																																																																																																				
	CP/BCD	CL	PS																																																																																																																																																		
__ 0 0	Always off	Always off	Always off																																																																																																																																																		
__ 0 2	RD	RD	RD																																																																																																																																																		
__ 0 3	ALM	ALM	ALM																																																																																																																																																		
__ 0 4	INP	INP	INP																																																																																																																																																		
__ 0 5	MBR	MBR	MBR																																																																																																																																																		
__ 0 6 (Note 2)	DB	DB	DB																																																																																																																																																		
__ 0 7	TLC	TLC	TLC																																																																																																																																																		
__ 0 8	WNG	WNG	WNG																																																																																																																																																		
__ 0 9	BWNG	BWNG	BWNG																																																																																																																																																		
__ 0 A	SA	SA	Always off																																																																																																																																																		
__ 0 B	Always off	Always off	Always off																																																																																																																																																		
__ 0 C	ZSP	ZSP	ZSP																																																																																																																																																		
__ 0 D (Note 2)	MTTR	MTTR	MTTR																																																																																																																																																		
__ 0 F	CDPS	CDPS	CDPS																																																																																																																																																		
__ 1 0 (Note 2)	CLDS	CLDS	CLDS																																																																																																																																																		
__ 1 1	ABSV	ABSV	ABSV																																																																																																																																																		
__ 1 F (Note 2)	CPCC (Note 4)	CPCC (Note 4)	▤																																																																																																																																																		
__ 2 3	CPO	CPO	CPO																																																																																																																																																		
__ 2 4	ZP	ZP	ZP																																																																																																																																																		
__ 2 5	POT	POT	Always off																																																																																																																																																		
__ 2 6	PUS	PUS	Always off																																																																																																																																																		
__ 2 7	MEND	MEND	MEND																																																																																																																																																		
__ 2 9 (Note 2)	CLTS (Note 4)	CLTS (Note 4)	▤																																																																																																																																																		
__ 2 B (Note 2)	CLTSM (Note 4)	CLTSM (Note 4)	▤																																																																																																																																																		
__ 2 C	PED	PED	▤																																																																																																																																																		
__ 2 D	▤	SOUT	▤																																																																																																																																																		
__ 2 E	▤	OUT1	▤																																																																																																																																																		
__ 2 F	▤	OUT2	▤																																																																																																																																																		
__ 3 0	▤	OUT3	▤																																																																																																																																																		
__ 3 1	ALMWNG	ALMWNG	ALMWNG																																																																																																																																																		
__ 3 2	BW9F	BW9F	BW9F																																																																																																																																																		
__ 3 3	MSDH	MSDH	▤																																																																																																																																																		
__ 3 4	MSDL	MSDL	▤																																																																																																																																																		
__ 3 7 (Note 2)	CAMS (Note 4)	CAMS (Note 4)	▤																																																																																																																																																		

7. PARAMETERS

No./ symbol/name	Setting digit	Function	Initial value [unit]	Control mode																																									
				CP/BCD	CL	PS																																							
PD23 *DO1 Output device selection 1	<table border="1"> <thead> <tr> <th rowspan="2">Setting value</th> <th colspan="3">Output device (Note 1)</th> </tr> <tr> <th>CP/BCD</th> <th>CL</th> <th>PS</th> </tr> </thead> <tbody> <tr> <td>__ 3 8 (Note 3)</td> <td>PT0</td> <td style="text-align: center;">/</td> <td>PS0</td> </tr> <tr> <td>__ 3 9 (Note 3)</td> <td>PT1</td> <td style="text-align: center;">/</td> <td>PS1</td> </tr> <tr> <td>__ 3 A (Note 3)</td> <td>PT2</td> <td style="text-align: center;">/</td> <td>PS2</td> </tr> <tr> <td>__ 3 B (Note 3)</td> <td>PT3</td> <td style="text-align: center;">/</td> <td>PS3</td> </tr> <tr> <td>__ 3 C (Note 3)</td> <td>PT4</td> <td style="text-align: center;">/</td> <td>PS4</td> </tr> <tr> <td>__ 3 D (Note 3)</td> <td>PT5</td> <td style="text-align: center;">/</td> <td>PS5</td> </tr> <tr> <td>__ 3 E (Note 3)</td> <td>PT6</td> <td style="text-align: center;">/</td> <td>PS6</td> </tr> <tr> <td>__ 3 F (Note 3)</td> <td>PT7</td> <td style="text-align: center;">/</td> <td>PS7</td> </tr> </tbody> </table>		Setting value	Output device (Note 1)			CP/BCD	CL	PS	__ 3 8 (Note 3)	PT0	/	PS0	__ 3 9 (Note 3)	PT1	/	PS1	__ 3 A (Note 3)	PT2	/	PS2	__ 3 B (Note 3)	PT3	/	PS3	__ 3 C (Note 3)	PT4	/	PS4	__ 3 D (Note 3)	PT5	/	PS5	__ 3 E (Note 3)	PT6	/	PS6	__ 3 F (Note 3)	PT7	/	PS7				
	Setting value	Output device (Note 1)																																											
		CP/BCD	CL	PS																																									
	__ 3 8 (Note 3)	PT0	/	PS0																																									
	__ 3 9 (Note 3)	PT1	/	PS1																																									
	__ 3 A (Note 3)	PT2	/	PS2																																									
	__ 3 B (Note 3)	PT3	/	PS3																																									
	__ 3 C (Note 3)	PT4	/	PS4																																									
	__ 3 D (Note 3)	PT5	/	PS5																																									
__ 3 E (Note 3)	PT6	/	PS6																																										
__ 3 F (Note 3)	PT7	/	PS7																																										
<p>Note 1. CP: Positioning mode (point table method) CL: Positioning mode (program method) PS: Positioning mode (indexer method) The diagonal lines indicate manufacturer settings. Never change the setting.</p> <p>2. It cannot be set with MR-J4-03A6-RJ servo amplifiers.</p> <p>3. For MR-J4-03A6-RJ servo amplifiers, up to six points of DO are available; therefore, PT0 to PT7 or PS0 to PS7 cannot be output simultaneously.</p> <p>4. This is available with servo amplifiers with software version B7 or later.</p>																																													
PD24 *DO2 Output device selection 2	__ x x	Device selection Any output device can be assigned to the CN1-23 pin. Refer to table 7.11 in [Pr. PD23] for settings.	0Ch	<input type="radio"/>	<input type="radio"/>	<input type="radio"/>																																							
	__ x __	For manufacturer setting	0h	/	/	/																																							
	x __ __		0h	/	/	/																																							
PD25 *DO3 Output device selection 3	__ x x	Device selection Any output device can be assigned to the CN1-24 pin. Refer to table 7.11 in [Pr. PD23] for settings.	04h	<input type="radio"/>	<input type="radio"/>	<input type="radio"/>																																							
	__ x __	For manufacturer setting	0h	/	/	/																																							
	x __ __		0h	/	/	/																																							
PD26 *DO4 Output device selection 4	__ x x	Device selection Any output device can be assigned to the CN1-25 pin. Refer to table 7.11 in [Pr. PD23] for settings.	07h	<input type="radio"/>	<input type="radio"/>	<input type="radio"/>																																							
	__ x __	For manufacturer setting	0h	/	/	/																																							
	x __ __		0h	/	/	/																																							
PD28 *DO6 Output device selection 6	__ x x	Device selection Any output device can be assigned to the CN1-49 pin. Refer to table 7.11 in [Pr. PD23] for settings.	02h	<input type="radio"/>	<input type="radio"/>	<input type="radio"/>																																							
	__ x __	For manufacturer setting	0h	/	/	/																																							
	x __ __		0h	/	/	/																																							

7. PARAMETERS

No./ symbol/name	Setting digit	Function	Initial value [unit]	Control mode		
				CP/BCD	CF	PS
PD29	Select a filter for the input signal.					
*DIF Input filter setting	___x	Input signal filter selection If external input signal causes chattering due to noise, etc., input filter is used to suppress it. 0: None 1: 0.888 [ms] 2: 1.777 [ms] 3: 2.666 [ms] 4: 3.555 [ms] 5: 4.444 [ms] 6: 5.333 [ms]	4h	<input type="radio"/>	<input type="radio"/>	<input type="radio"/>
	__x_	RES (Reset) dedicated filter selection 0: Disabled 1: Enabled (50 [ms])	0h	<input type="radio"/>	<input type="radio"/>	<input type="radio"/>
	_x__	CR (Clear) dedicated filter selection 0: Disabled 1: Enabled (50 [ms])	0h	<input type="radio"/>	<input type="radio"/>	<input type="radio"/>
	x___	For manufacturer setting	0h	<input type="checkbox"/>	<input type="checkbox"/>	<input type="checkbox"/>

7. PARAMETERS

No./ symbol/name	Setting digit	Function	Initial value [unit]	Control mode																			
				CP/BCD	CL	PS																	
PD30 *DOP1 Function selection D-1	___x	Stop method selection for LSP (Forward rotation stroke end) off or LSN (Reverse rotation stroke end) off Select a stop method for LSP (Forward rotation stroke end) off or LSN (Reverse rotation stroke end) off. (Refer to section 7.5.) <table border="1" style="margin: 10px auto; width: 80%;"> <thead> <tr> <th rowspan="2">Setting value</th> <th colspan="2">Control mode</th> </tr> <tr> <th>CP/BCD/CL</th> <th>PS</th> </tr> </thead> <tbody> <tr> <td>0</td> <td colspan="2">Quick stop (home position erased)</td> </tr> <tr> <td>1</td> <td colspan="2">Slow stop (home position erased)</td> </tr> <tr> <td>2</td> <td>Slow stop (deceleration to a stop by deceleration time constant)</td> <td>Slow stop (home position erased)</td> </tr> <tr> <td>3</td> <td>Quick stop (stop by clearing remaining distance)</td> <td>Quick stop (home position erased)</td> </tr> </tbody> </table>	Setting value	Control mode		CP/BCD/CL	PS	0	Quick stop (home position erased)		1	Slow stop (home position erased)		2	Slow stop (deceleration to a stop by deceleration time constant)	Slow stop (home position erased)	3	Quick stop (stop by clearing remaining distance)	Quick stop (home position erased)	0h	○	○	○
	Setting value	Control mode																					
		CP/BCD/CL	PS																				
	0	Quick stop (home position erased)																					
1	Slow stop (home position erased)																						
2	Slow stop (deceleration to a stop by deceleration time constant)	Slow stop (home position erased)																					
3	Quick stop (stop by clearing remaining distance)	Quick stop (home position erased)																					
__x_	Base circuit status selection for RES (Reset) on 0: Base circuit shut-off 1: No base circuit shut-off	0h	○	○	○																		
_x__	Stop method selection at software limit detection Select a stop method selection at software limit detection. (Refer to section 7.6.) 0: Quick stop (home position erased) 1: Slow stop (home position erased) 2: Slow stop (deceleration to a stop by deceleration time constant) 3: Quick stop (stop by clearing remaining distance)	0h	○	○	/																		
x___	Enabled/disabled selection for a thermistor of servo motor or linear servo motor 0: Enabled 1: Disabled The setting in this digit will be disabled when using a servo motor or linear servo motor without thermistor.	0h	○	○	○																		
PD31 *DOP2 Function selection D-2	___x	For manufacturer setting	0h	/	/	/																	
	__x_		0h	/	/	/																	
	_x__	INP (In-position) on condition selection Select a condition that INP (In-position) is turned on. 0: Droop pulses are within the in-position range. 1: The command pulse frequency is 0, and droop pulses are within the in-position range. When the position command is not inputted for about 1 ms, the command pulse frequency is decided as 0. This parameter is used by servo amplifier with software version B4 or later.	0h	○	○	○																	
x___	Mark detection fast input signal filter selection 0: Standard 0.166 [ms] 1: 0.055 [ms] 2: 0.111 [ms] 3: 0.166 [ms] 4: 0.222 [ms] 5: 0.277 [ms] 6: 0.333 [ms] 7: 0.388 [ms] 8: 0.444 [ms] 9 to E: Disabled (Setting this will be the same as "F"). F: Non-filter This digit will be enabled when MSD (Mark detection) is assigned to the CN1-10 pin with [Pr. PD44].	0h	○	○	/																		

7. PARAMETERS

No./ symbol/name	Setting digit	Function	Initial value [unit]	Control mode							
				CP/BCD	CL	PS					
PD32 *DOP3 Function selection D-3	___x	CR (Clear) selection This is used to set CR (Clear). 0: Deleting droop pulses by turning on the device 1: Continuous deleting of droop pulses during the device on 2: Disabled	0h	<input type="radio"/>	<input type="radio"/>	<input type="radio"/>					
	__x_	For manufacturer setting	0h	<input type="checkbox"/>	<input type="checkbox"/>	<input type="checkbox"/>					
	_x__		0h	<input type="checkbox"/>	<input type="checkbox"/>	<input type="checkbox"/>					
	x___		0h	<input type="checkbox"/>	<input type="checkbox"/>	<input type="checkbox"/>					
PD33 *DOP4 Function selection D-4	___x	For manufacturer setting	0h	<input type="checkbox"/>	<input type="checkbox"/>	<input type="checkbox"/>					
	__x_		0h	<input type="checkbox"/>	<input type="checkbox"/>	<input type="checkbox"/>					
	_x__	Rotation direction selection to enable torque limit/travel direction selection to enable thrust limit Select a direction which enables internal torque limit 2 or external torque limit. 0: Both of "CCW or positive direction" and "CW or negative direction" are enabled. 1: Enabled with "CCW or positive direction" 2: Enabled with "CW or negative direction"	0h	<input type="radio"/>	<input type="radio"/>	<input type="radio"/>					
PD34 *DOP5 Function selection D-5	x___	For manufacturer setting	0h	<input type="checkbox"/>	<input type="checkbox"/>	<input type="checkbox"/>					
	___x	Alarm code output Select an output alarm codes. When an alarm occurs, the alarm code is outputted to CN1-22, CN1-23, and CN1-24 pins. 0: Disabled 1: Enabled For details of the alarm codes, refer to chapter 8. When "1" is set for this digit, setting the following will trigger [AL. 37 Parameter error]. • "___1" is set in [Pr. PA03] and the absolute position detection system by DIO is selected. • MBR, DB, or ALM is assigned to the CN1-22 pin, CN1-23 pin, or CN1-24 pin.	0h	<input type="radio"/>	<input type="radio"/>	<input type="radio"/>					
	__x_	Selection of output device at warning occurrence Select ALM (Malfunction) output status for when an warning occurs.	0h	<input type="radio"/>	<input type="radio"/>	<input type="radio"/>					
		<table border="1" style="width: 100%; border-collapse: collapse;"> <thead> <tr> <th style="width: 15%;">Setting value</th> <th style="width: 85%;">Device status</th> </tr> </thead> <tbody> <tr> <td style="text-align: center;">0</td> <td> <div style="display: flex; justify-content: space-between;"> <div style="width: 30%;"> <p>WNG ON OFF</p> <p>ALM ON OFF</p> </div> <div style="width: 65%;"> </div> </div> </td> </tr> <tr> <td style="text-align: center;">1</td> <td> <div style="display: flex; justify-content: space-between;"> <div style="width: 30%;"> <p>WNG ON OFF</p> <p>ALM ON OFF</p> </div> <div style="width: 65%;"> </div> </div> </td> </tr> </tbody> </table>	Setting value	Device status	0	<div style="display: flex; justify-content: space-between;"> <div style="width: 30%;"> <p>WNG ON OFF</p> <p>ALM ON OFF</p> </div> <div style="width: 65%;"> </div> </div>	1	<div style="display: flex; justify-content: space-between;"> <div style="width: 30%;"> <p>WNG ON OFF</p> <p>ALM ON OFF</p> </div> <div style="width: 65%;"> </div> </div>			
Setting value	Device status										
0	<div style="display: flex; justify-content: space-between;"> <div style="width: 30%;"> <p>WNG ON OFF</p> <p>ALM ON OFF</p> </div> <div style="width: 65%;"> </div> </div>										
1	<div style="display: flex; justify-content: space-between;"> <div style="width: 30%;"> <p>WNG ON OFF</p> <p>ALM ON OFF</p> </div> <div style="width: 65%;"> </div> </div>										
	_x__	For manufacturer setting	0h	<input type="checkbox"/>	<input type="checkbox"/>	<input type="checkbox"/>					
	x___		0h	<input type="checkbox"/>	<input type="checkbox"/>	<input type="checkbox"/>					

7. PARAMETERS

No./ symbol/name	Setting digit	Function	Initial value [unit]	Control mode		
				CP/BCD	CL	PS
PD41 *DIA3 Input signal automatic on selection 3	Select input devices to turn on them automatically.					
	____x (HEX)	____x (BIN): MD0 (operation mode selection 1) 0: Disabled (Use for an external input signal.) 1: Enabled (automatic on)	0h	<input type="checkbox"/>	<input type="checkbox"/>	<input type="checkbox"/>
		__x_ (BIN): MD1 (operation mode selection 2) 0: Disabled (Use for an external input signal.) 1: Enabled (automatic on)		<input type="checkbox"/>	<input type="checkbox"/>	<input type="checkbox"/>
		_x__ (BIN): For manufacturer setting		<input type="checkbox"/>	<input type="checkbox"/>	<input type="checkbox"/>
		x___ (BIN): For manufacturer setting		<input type="checkbox"/>	<input type="checkbox"/>	<input type="checkbox"/>
		___x_ (BIN): For manufacturer setting		<input type="checkbox"/>	<input type="checkbox"/>	<input type="checkbox"/>
	__x_ (HEX)	___x_ (BIN): For manufacturer setting	0h	<input type="checkbox"/>	<input type="checkbox"/>	<input type="checkbox"/>
		__x_ (BIN): For manufacturer setting		<input type="checkbox"/>	<input type="checkbox"/>	<input type="checkbox"/>
		_x__ (BIN): OVR (Analog override selection) 0: Disabled (Use for an external input signal.) 1: Enabled (automatic on)		<input type="checkbox"/>	<input type="checkbox"/>	<input type="checkbox"/>
		x___ (BIN): For manufacturer setting		<input type="checkbox"/>	<input type="checkbox"/>	<input type="checkbox"/>
	_x__ (HEX)	___x_ (BIN): For manufacturer setting	0h	<input type="checkbox"/>	<input type="checkbox"/>	<input type="checkbox"/>
		__x_ (BIN): For manufacturer setting		<input type="checkbox"/>	<input type="checkbox"/>	<input type="checkbox"/>
		_x__ (BIN): For manufacturer setting		<input type="checkbox"/>	<input type="checkbox"/>	<input type="checkbox"/>
		x___ (BIN): For manufacturer setting		<input type="checkbox"/>	<input type="checkbox"/>	<input type="checkbox"/>
	x___ (HEX)	___x_ (BIN): For manufacturer setting	0h	<input type="checkbox"/>	<input type="checkbox"/>	<input type="checkbox"/>
		__x_ (BIN): For manufacturer setting		<input type="checkbox"/>	<input type="checkbox"/>	<input type="checkbox"/>
		_x__ (BIN): For manufacturer setting		<input type="checkbox"/>	<input type="checkbox"/>	<input type="checkbox"/>
		x___ (BIN): For manufacturer setting		<input type="checkbox"/>	<input type="checkbox"/>	<input type="checkbox"/>
	Convert the setting value into hexadecimal as follows.					
PD42 *DIA4 Input signal automatic on selection 4	Select input devices to turn on them automatically.					
	____x (HEX)	____x (BIN): For manufacturer setting	0h	<input type="checkbox"/>	<input type="checkbox"/>	<input type="checkbox"/>
		__x_ (BIN): RT (Second acceleration/deceleration selection) 0: Disabled (Use for an external input signal.) 1: Enabled (automatic on)		<input type="checkbox"/>	<input type="checkbox"/>	<input type="checkbox"/>
		_x__ (BIN): RTCDP (Second acceleration/deceleration gain selection) 0: Disabled (Use for an external input signal.) 1: Enabled (automatic on)		<input type="checkbox"/>	<input type="checkbox"/>	<input type="checkbox"/>
		x___ (BIN): For manufacturer setting		<input type="checkbox"/>	<input type="checkbox"/>	<input type="checkbox"/>
		___x_ (BIN): For manufacturer setting		<input type="checkbox"/>	<input type="checkbox"/>	<input type="checkbox"/>
	__x_ (HEX)	___x_ (BIN): For manufacturer setting	0h	<input type="checkbox"/>	<input type="checkbox"/>	<input type="checkbox"/>
		__x_ (BIN): For manufacturer setting		<input type="checkbox"/>	<input type="checkbox"/>	<input type="checkbox"/>
		_x__ (BIN): For manufacturer setting		<input type="checkbox"/>	<input type="checkbox"/>	<input type="checkbox"/>
		x___ (BIN): For manufacturer setting		<input type="checkbox"/>	<input type="checkbox"/>	<input type="checkbox"/>
___x_ (BIN): For manufacturer setting		<input type="checkbox"/>		<input type="checkbox"/>	<input type="checkbox"/>	

7. PARAMETERS

No./ symbol/name	Setting digit	Function	Initial value [unit]	Control mode																
				CP/BCD	OL	PS														
PD42 *DIA4 Input signal automatic on selection 4	_ x _ _ (HEX)	__ _ x (BIN): DI0 (point table No./Program No./next station No. selection 1) 0: Disabled (Use for an external input signal.) 1: Enabled (automatic on)	0h	<input type="checkbox"/>	<input type="checkbox"/>	<input type="checkbox"/>														
		_ _ x _ (BIN): DI1 (point table No./program No./next station No. selection 2) 0: Disabled (Use for an external input signal.) 1: Enabled (automatic on)		<input type="checkbox"/>	<input type="checkbox"/>	<input type="checkbox"/>														
		_ x _ _ (BIN): DI2 (point table No./program No./next station No. selection 3) 0: Disabled (Use for an external input signal.) 1: Enabled (automatic on)		<input type="checkbox"/>	<input type="checkbox"/>	<input type="checkbox"/>														
		x _ _ _ (BIN): DI3 (point table No./program No./next station No. selection 4) 0: Disabled (Use for an external input signal.) 1: Enabled (automatic on)		<input type="checkbox"/>	<input type="checkbox"/>	<input type="checkbox"/>														
	x _ _ _ (HEX)	__ _ x (BIN): DI4 (point table No./Program No./next station No. selection 5) 0: Disabled (Use for an external input signal.) 1: Enabled (automatic on)		0h	<input type="checkbox"/>	<input type="checkbox"/>	<input type="checkbox"/>													
		_ _ x _ (BIN): DI5 (point table No./program No./next station No. selection 6) 0: Disabled (Use for an external input signal.) 1: Enabled (automatic on)			<input type="checkbox"/>	<input type="checkbox"/>	<input type="checkbox"/>													
		_ x _ _ (BIN): DI6 (point table No./program No./next station No. selection 7) 0: Disabled (Use for an external input signal.) 1: Enabled (automatic on)			<input type="checkbox"/>	<input type="checkbox"/>	<input type="checkbox"/>													
		x _ _ _ (BIN): DI7 (point table No./program No./next station No. selection 8) 0: Disabled (Use for an external input signal.) 1: Enabled (automatic on)			<input type="checkbox"/>	<input type="checkbox"/>	<input type="checkbox"/>													
Convert the setting value into hexadecimal as follows.																				
<table border="1"> <thead> <tr> <th rowspan="2">Input device</th> <th colspan="2">Initial value</th> </tr> <tr> <th>BIN</th> <th>HEX</th> </tr> </thead> <tbody> <tr> <td>RT (Second acceleration/deceleration selection)</td> <td>0</td> <td rowspan="3">0</td> </tr> <tr> <td>RTCDP (Second acceleration/deceleration gain selection)</td> <td>0</td> </tr> <tr> <td></td> <td>0</td> </tr> </tbody> </table>							Input device	Initial value		BIN	HEX	RT (Second acceleration/deceleration selection)	0	0	RTCDP (Second acceleration/deceleration gain selection)	0		0		
Input device	Initial value																			
	BIN	HEX																		
RT (Second acceleration/deceleration selection)	0	0																		
RTCDP (Second acceleration/deceleration gain selection)	0																			
	0																			
<table border="1"> <thead> <tr> <th rowspan="2">Input device</th> <th colspan="2">Initial value</th> </tr> <tr> <th>BIN</th> <th>HEX</th> </tr> </thead> <tbody> <tr> <td>DI0 (Point table No./Program No./Next station No. selection 1)</td> <td>0</td> <td rowspan="4">0</td> </tr> <tr> <td>DI1 (Point table No./Program No./Next station No. selection 2)</td> <td>0</td> </tr> <tr> <td>DI2 (Point table No./Program No./Next station No. selection 3)</td> <td>0</td> </tr> <tr> <td>DI3 (Point table No./Program No./Next station No. selection 4)</td> <td>0</td> </tr> </tbody> </table>							Input device	Initial value		BIN	HEX	DI0 (Point table No./Program No./Next station No. selection 1)	0	0	DI1 (Point table No./Program No./Next station No. selection 2)	0	DI2 (Point table No./Program No./Next station No. selection 3)	0	DI3 (Point table No./Program No./Next station No. selection 4)	0
Input device	Initial value																			
	BIN	HEX																		
DI0 (Point table No./Program No./Next station No. selection 1)	0	0																		
DI1 (Point table No./Program No./Next station No. selection 2)	0																			
DI2 (Point table No./Program No./Next station No. selection 3)	0																			
DI3 (Point table No./Program No./Next station No. selection 4)	0																			
<table border="1"> <thead> <tr> <th rowspan="2">Input device</th> <th colspan="2">Initial value</th> </tr> <tr> <th>BIN</th> <th>HEX</th> </tr> </thead> <tbody> <tr> <td>DI4 (Point table No./Program No./Next station No. selection 5)</td> <td>0</td> <td rowspan="4">0</td> </tr> <tr> <td>DI5 (Point table No./Program No./Next station No. selection 6)</td> <td>0</td> </tr> <tr> <td>DI6 (Point table No./Program No./Next station No. selection 7)</td> <td>0</td> </tr> <tr> <td>DI7 (Point table No./Program No./Next station No. selection 8)</td> <td>0</td> </tr> </tbody> </table>							Input device	Initial value		BIN	HEX	DI4 (Point table No./Program No./Next station No. selection 5)	0	0	DI5 (Point table No./Program No./Next station No. selection 6)	0	DI6 (Point table No./Program No./Next station No. selection 7)	0	DI7 (Point table No./Program No./Next station No. selection 8)	0
Input device	Initial value																			
	BIN	HEX																		
DI4 (Point table No./Program No./Next station No. selection 5)	0	0																		
DI5 (Point table No./Program No./Next station No. selection 6)	0																			
DI6 (Point table No./Program No./Next station No. selection 7)	0																			
DI7 (Point table No./Program No./Next station No. selection 8)	0																			
BIN 0: Use for an external input signal. BIN 1: Automatic on																				

7. PARAMETERS

No./ symbol/name	Setting digit	Function	Initial value [unit]	Control mode		
				CP/BCD	CL	PS
PD44 *DI11H Input device selection 11H	Any input device can be assigned to the CN1-10 pin/CN1-37 pin.					
	__ x x	Not used with the positioning mode.	00h			
x x __	Positioning mode - Device selection Refer to table 7.10 in [Pr. PD04] for setting values. When "00" is set, PP/PP2 (Forward rotation pulse/Manual pulse generator) will be assigned. The CN1-37 pin is available with servo amplifiers having software version B7 or later, and manufactured in January, 2015 or later.		3Ah	○	○	
	PD46 *DI12H Input device selection 12H	Any input device can be assigned to the CN1-35 pin and the CN1-38 pin.				
__ x x	Not used with the positioning mode.		00h			
x x __	Positioning mode - Device selection Refer to table 7.10 in [Pr. PD04] for setting values. When "00" is set, NP/NP2 (Reverse rotation pulse/Manual pulse generator) will be assigned. The CN1-38 pin is available with servo amplifiers having software version B7 or later, and manufactured in January, 2015 or later.		3Bh	○	○	
PD47 *DO7 Output device selection 7	Any output device can be assigned to the CN1-13 pin and CN1-14 pin. This parameter is not available with MR-J4-03A6-RJ servo amplifiers.					
	__ x x	Device selection Any output device can be assigned to the CN1-13 pin. Refer to table 7.11 in [Pr. PD23] for setting values.	00h	○	○	○
x x __	Device selection Any output device can be assigned to the CN1-14 pin. Refer to table 7.11 in [Pr. PD23] for setting values.		00h	○	○	○

7. PARAMETERS

7.2.5 Extension setting 2 parameters ([Pr. PE__])

No./ symbol/name	Setting digit	Function	Initial value [unit]	Control mode																																																																								
				CP/BCD	CL	P.S																																																																						
PE03 *FCT2 Fully closed loop function selection 2	__ x x	<p>Fully closed loop control error detection function selection Select the fully closed loop control error detection function. This digit is not available with MR-J4-03A6-RJ servo amplifiers.</p> <p>○: Abnormal detection enabled -: Abnormal detection disabled</p> <table border="1"> <thead> <tr> <th rowspan="3">Setting value</th> <th rowspan="3">Speed deviation error</th> <th colspan="3">Position deviation error</th> </tr> <tr> <th colspan="2">During servo-on</th> <th rowspan="2">During servo-off</th> </tr> <tr> <th>With command</th> <th>0 command</th> </tr> </thead> <tbody> <tr><td>__ 00</td><td>-</td><td>-</td><td>-</td><td>-</td></tr> <tr><td>__ 01</td><td>○</td><td>-</td><td>-</td><td>-</td></tr> <tr><td>__ 02</td><td>-</td><td>○</td><td>○</td><td>○</td></tr> <tr><td>__ 03</td><td>○</td><td>○</td><td>○</td><td>○</td></tr> <tr><td>__ 10</td><td>-</td><td>-</td><td>-</td><td>-</td></tr> <tr><td>__ 11</td><td>○</td><td>-</td><td>-</td><td>-</td></tr> <tr><td>__ 12</td><td>-</td><td>-</td><td>○</td><td>-</td></tr> <tr><td>__ 13</td><td>○</td><td>-</td><td>○</td><td>-</td></tr> <tr><td>__ 20</td><td>-</td><td>-</td><td>-</td><td>-</td></tr> <tr><td>__ 21</td><td>○</td><td>-</td><td>-</td><td>-</td></tr> <tr><td>__ 22</td><td>-</td><td>-</td><td>○</td><td>○</td></tr> <tr><td>__ 23</td><td>○</td><td>-</td><td>○</td><td>○</td></tr> </tbody> </table>	Setting value	Speed deviation error	Position deviation error			During servo-on		During servo-off	With command	0 command	__ 00	-	-	-	-	__ 01	○	-	-	-	__ 02	-	○	○	○	__ 03	○	○	○	○	__ 10	-	-	-	-	__ 11	○	-	-	-	__ 12	-	-	○	-	__ 13	○	-	○	-	__ 20	-	-	-	-	__ 21	○	-	-	-	__ 22	-	-	○	○	__ 23	○	-	○	○	03h	○	○	
	Setting value	Speed deviation error			Position deviation error																																																																							
					During servo-on		During servo-off																																																																					
With command			0 command																																																																									
__ 00	-	-	-	-																																																																								
__ 01	○	-	-	-																																																																								
__ 02	-	○	○	○																																																																								
__ 03	○	○	○	○																																																																								
__ 10	-	-	-	-																																																																								
__ 11	○	-	-	-																																																																								
__ 12	-	-	○	-																																																																								
__ 13	○	-	○	-																																																																								
__ 20	-	-	-	-																																																																								
__ 21	○	-	-	-																																																																								
__ 22	-	-	○	○																																																																								
__ 23	○	-	○	○																																																																								
	_ x _ _	For manufacturer setting	0h																																																																									
	x _ _ _	<p>Fully closed loop control error reset selection 0: Reset disabled (reset by powering off/on enabled) 1: Reset enabled This digit is not available with MR-J4-03A6-RJ servo amplifiers.</p>	0h	○	○																																																																							
PE04 *FBN Fully closed loop control - Feedback pulse electronic gear 1 - Numerator		<p>Set a numerator of electronic gear for the servo motor encoder pulse at the fully closed loop control. Set the electronic gear so that the number of servo motor encoder pulses for one servo motor revolution is converted to the resolution of the load-side encoder. This parameter is not available with MR-J4-03A6-RJ servo amplifiers.</p> <p>Setting range: 1 to 65535</p>	1	○	○																																																																							
PE05 *FBD Fully closed loop control - Feedback pulse electronic gear 1 - Denominator		<p>Set a denominator of electronic gear for the servo motor encoder pulse at the fully closed loop control. Set the electronic gear so that the number of servo motor encoder pulses for one servo motor revolution is converted to the resolution of the load-side encoder. This parameter is not available with MR-J4-03A6-RJ servo amplifiers.</p> <p>Setting range: 1 to 65535</p>	1	○	○																																																																							
PE06 BC1 Fully closed loop control - Speed deviation error detection level		<p>Set [AL. 42.9 Fully closed loop control error by speed deviation] of the fully closed loop control error detection. When the speed deviation between the servo motor encoder and load-side encoder becomes larger than the setting value, the alarm will occur. This parameter is not available with MR-J4-03A6-RJ servo amplifiers.</p> <p>Setting range: 1 to 50000</p>	400 [r/min]/ [mm/s]	○	○																																																																							

7. PARAMETERS

No./ symbol/name	Setting digit	Function	Initial value [unit]	Control mode		
				CP/BCD	CL	PS
PE07 BC2 Fully closed loop control - Position deviation error detection level		Set [AL. 42.8 Fully closed loop control error by position deviation] of the fully closed loop control error detection. When the position deviation between the servo motor encoder and load-side encoder becomes larger than the setting value, the alarm will occur. This parameter is not available with MR-J4-03A6-RJ servo amplifiers. Setting range: 1 to 20000	100 [kpulse]	<input type="radio"/>	<input type="radio"/>	<input type="radio"/>
PE08 DUF Fully closed loop dual feedback filter		Set a dual feedback filter band. For details, refer to section 17.3.1 (5) of "MR-J4-_A_(-RJ) Servo Amplifier Instruction Manual". This parameter is not available with MR-J4-03A6-RJ servo amplifiers. Setting range: 1 to 4500	10 [rad/s]	<input type="radio"/>	<input type="radio"/>	<input type="radio"/>
PE10 FCT3 Fully closed loop function selection 3	___ x	For manufacturer setting	0h	<input type="radio"/>	<input type="radio"/>	<input type="radio"/>
	__ x _	Fully closed loop control - Position deviation error detection level - Unit selection 0: 1 kpulse unit 1: 1 pulse unit This digit is not available with MR-J4-03A6-RJ servo amplifiers.	0h	<input type="radio"/>	<input type="radio"/>	<input type="radio"/>
	_ x _ _	For manufacturer setting	0h	<input type="radio"/>	<input type="radio"/>	<input type="radio"/>
	x _ _ _	For manufacturer setting	0h	<input type="radio"/>	<input type="radio"/>	<input type="radio"/>
PE34 *FBN2 Fully closed loop control - Feedback pulse electronic gear 2 - Numerator		Set a numerator of electronic gear for the servo motor encoder pulse at the fully closed loop control. Set the electronic gear so that the number of servo motor encoder pulses for one servo motor revolution is converted to the resolution of the load-side encoder. For details, refer to section 17.3.1 (5) of "MR-J4-_A_(-RJ) Servo Amplifier Instruction Manual". This parameter is not available with MR-J4-03A6-RJ servo amplifiers. Setting range: 1 to 65535	1	<input type="radio"/>	<input type="radio"/>	<input type="radio"/>
PE35 *FBD2 Fully closed loop control - Feedback pulse electronic gear 2 - Denominator		Set a denominator of electronic gear for the servo motor encoder pulse at the fully closed loop control. Set the electronic gear so that the number of servo motor encoder pulses for one servo motor revolution is converted to the resolution of the load-side encoder. For details, refer to section 17.3.1 (5) of "MR-J4-_A_(-RJ) Servo Amplifier Instruction Manual". This parameter is not available with MR-J4-03A6-RJ servo amplifiers. Setting range: 1 to 65535	1	<input type="radio"/>	<input type="radio"/>	<input type="radio"/>
PE41 EOP3 Function selection E-3	___ x	Robust filter selection 0: Disabled 1: Enabled When you select "Enabled" of this digit, the machine resonance suppression filter 5 set in [Pr. PB51] is not available.	0h	<input type="radio"/>	<input type="radio"/>	<input type="radio"/>
	__ x _	For manufacturer setting	0h	<input type="radio"/>	<input type="radio"/>	<input type="radio"/>
	_ x _ _	For manufacturer setting	0h	<input type="radio"/>	<input type="radio"/>	<input type="radio"/>
	x _ _ _	For manufacturer setting	0h	<input type="radio"/>	<input type="radio"/>	<input type="radio"/>
PE44 LMCP Lost motion compensation positive-side compensation value selection		Set the lost motion compensation for when reverse rotation (CW) switches to forward rotation (CCW) in increments of 0.01% assuming the rated torque as 100%. This parameter is available with servo amplifiers with software version B4 or later. Setting range: 0 to 30000	0 [0.01%]	<input type="radio"/>	<input type="radio"/>	<input type="radio"/>

7. PARAMETERS

No./ symbol/name	Setting digit	Function	Initial value [unit]	Control mode		
				CP/BCD	CL	PS
PE45 LMCN Lost motion compensation negative-side compensation value selection		Set the lost motion compensation for when forward rotation (CCW) switches to reverse rotation (CW) in increments of 0.01% assuming the rated torque as 100%. This parameter is available with servo amplifiers with software version B4 or later. Setting range: 0 to 30000	0 [0.01%]	<input type="radio"/>	<input type="radio"/>	<input type="radio"/>
PE46 LMFLT Lost motion filter setting		Set the time constant of the lost motion compensation filter in increments of 0.1 ms. If the time constant is "0", the torque is compensated with the value set in [Pr. PE44] and [Pr. PE45]. If the time constant is other than "0", the torque is compensated with the high-pass filter output value of the set time constant, and the lost motion compensation will continue. This parameter is available with servo amplifiers with software version B4 or later. Setting range: 0 to 30000	0 [0.1 ms]	<input type="radio"/>	<input type="radio"/>	<input type="radio"/>
PE47 TOF Torque offset		Set this when canceling unbalanced torque of vertical axis. Set this assuming the rated torque of the servo motor as 100%. The torque offset does not need to be set for a machine not generating unbalanced torque. The torque offset cannot be used for linear servo motors and direct drive motors. Set 0.00%. This parameter is available with servo amplifiers with software version B4 or later. Setting range: -10000 to 10000	0 [0.01%]	<input type="radio"/>	<input type="radio"/>	<input type="radio"/>
PE48 *LMOP Lost motion compensation function selection	___x	Lost motion compensation selection 0: Disabled 1: Enabled This parameter is available with servo amplifiers with software version B4 or later.	0h	<input type="radio"/>	<input type="radio"/>	<input type="radio"/>
	__x_	Unit setting of lost motion compensation non-sensitive band 0: 1 pulse unit 1: 1 kpulse unit This parameter is available with servo amplifiers with software version B4 or later.	0h	<input type="radio"/>	<input type="radio"/>	<input type="radio"/>
	_x__	For manufacturer setting	0h	<input type="radio"/>	<input type="radio"/>	<input type="radio"/>
	x___		0h	<input type="radio"/>	<input type="radio"/>	<input type="radio"/>
PE49 LMCD Lost motion compensation timing		Set the lost motion compensation timing in increments of 0.1 ms. You can delay the timing to perform the lost motion compensation for the set time. This parameter is available with servo amplifiers with software version B4 or later. Setting range: 0 to 30000	0 [0.1 ms]	<input type="radio"/>	<input type="radio"/>	<input type="radio"/>
PE50 LMCT Lost motion compensation non-sensitive band		Set the lost motion compensation non-sensitive band. When the fluctuation of the droop pulse is the setting value or less, the speed will be 0. Setting can be changed in [Pr. PE48]. Set the parameter per encoder unit. This parameter is available with servo amplifiers with software version B4 or later. Setting range: 0 to 65535	0 [pulse]/ [kpulse]	<input type="radio"/>	<input type="radio"/>	<input type="radio"/>

7. PARAMETERS

7.2.6 Extension setting 3 parameters ([Pr. PF__])

No./ symbol/name	Setting digit	Function	Initial value [unit]	Control mode		
				CP/BCD	OL	PS
PF09 *FOP5 Function selection F-5	___ x	Electronic dynamic brake selection 0: Enabled only for specified servo motors 2: Disabled Refer to the following table for the specified servo motors.	0h	<input type="radio"/>	<input type="radio"/>	<input type="radio"/>
	__ x _	For manufacturer setting	0h	<input type="checkbox"/>	<input type="checkbox"/>	<input type="checkbox"/>
	_ x _ _		0h	<input type="checkbox"/>	<input type="checkbox"/>	<input type="checkbox"/>
	x _ _ _		0h	<input type="checkbox"/>	<input type="checkbox"/>	<input type="checkbox"/>
PF15 DBT Electronic dynamic brake operating time		Set an operating time for the electronic dynamic brake. Setting range: 0 to 10000	2000 [ms]	<input type="radio"/>	<input type="radio"/>	<input type="radio"/>
PF21 DRT Drive recorder switching time setting		Set a drive recorder switching time. When a graph function is terminated or a USB communication is cut during using a graph function, the function will be changed to the drive recorder function after the setting time of this parameter. When a value from "1" to "32767" is set, it will switch after the setting value. However, when "0" is set, it will switch after 600 s. When "-1" is set, the drive recorder function is disabled. Setting range: -1 to 32767	0 [s]	<input type="radio"/>	<input type="radio"/>	<input type="radio"/>
PF23 OSCL1 Vibration tough drive - Oscillation detection level		Set a filter readjustment sensitivity of [Pr. PB13 Machine resonance suppression filter 1] and [Pr. PB15 Machine resonance suppression filter 2] while the vibration tough drive is enabled. However, setting "0" will be 50%. Example: When you set "50" to the parameter, the filter will be readjusted at the time of 50% or more oscillation level. Setting range: 0 to 100	50 [%]	<input type="radio"/>	<input type="radio"/>	<input type="radio"/>
PF24 *OSCL2 Vibration tough drive function selection	___ x	Oscillation detection alarm selection Select alarm or warning when an oscillation continues at a filter readjustment sensitivity level of [Pr. PF23]. The digit is continuously enabled regardless of the vibration tough drive in [Pr. PA20]. 0: [AL. 54 Oscillation detection] will occur at oscillation detection. 1: [AL. F3.1 Oscillation detection warning] will occur at oscillation detection. 2: Oscillation detection function disabled	0h	<input type="radio"/>	<input type="radio"/>	<input type="radio"/>
	__ x _	For manufacturer setting	0h	<input type="checkbox"/>	<input type="checkbox"/>	<input type="checkbox"/>
	_ x _ _		0h	<input type="checkbox"/>	<input type="checkbox"/>	<input type="checkbox"/>
	x _ _ _		0h	<input type="checkbox"/>	<input type="checkbox"/>	<input type="checkbox"/>
PF25 CVAT SEMI-F47 function - Instantaneous power failure detection time		Set the time of the [AL. 10.1 Voltage drop in the control circuit power] occurrence. To disable the parameter, set "Disabled (_ 0 _)" of "SEMI-F47 function selection" in [Pr. PA20]. This parameter is not available with MR-J4-03A6-RJ servo amplifiers. Setting range: 30 to 200	200 [ms]	<input type="radio"/>	<input type="radio"/>	<input type="radio"/>

7. PARAMETERS

No./ symbol/name	Setting digit	Function	Initial value [unit]	Control mode		
				CP/BCD	CL	PS
PF31 FRIC Machine diagnosis function - Friction judgment speed		<p>Set a (linear) servo motor speed that divides a friction estimation area into high and low during the friction estimation process of the machine diagnosis. Setting "0" will set a value half of the rated speed. When your operation pattern is under the rated speed, we recommend that you set a half value of the maximum speed.</p> <p>Setting range: 0 to permissible speed</p>	0 [r/min]/ [mm/s]	<input type="radio"/>	<input type="radio"/>	<input type="radio"/>
PF34	___x	For manufacturer setting	0h	<input type="checkbox"/>	<input type="checkbox"/>	<input type="checkbox"/>
*SOP3	___x_		0h	<input type="checkbox"/>	<input type="checkbox"/>	<input type="checkbox"/>
RS-422	_x___		0h	<input type="checkbox"/>	<input type="checkbox"/>	<input type="checkbox"/>
communication function selection 3	x___	MR-PRU03 selection Select this if using an MR-PRU03. 0: Disabled 1: Enabled This digit is not available with MR-J4-03A6-RJ servo amplifiers.	0h	<input type="radio"/>	<input type="radio"/>	<input type="radio"/>

7. PARAMETERS

7.2.7 Linear servo motor/DD motor setting parameters ([Pr. PL__])

POINT

- The linear servo motor/DD motor setting parameters ([Pr. PL__]) can be used with the direct drive servo system for the indexer method.
- Linear servo motor/DD motor setting parameters ([Pr. PL__]) cannot be used with MR-J4-03A6-RJ servo amplifiers.

No./ symbol/name	Setting digit	Function	Initial value [unit]	Control mode																						
				CP/BCD	CL	PS																				
PL01 *LIT1 Linear servo motor/DD motor function selection 1	___x	Linear servo motor/DD motor magnetic pole detection selection The setting value "0" will be enabled only with absolute position linear encoders. 0: Magnetic pole detection disabled 1: Magnetic pole detection at first servo-on 5: Magnetic pole detection at every servo-on	1h	○	○	○																				
	__x_	For manufacturer setting	0h	/	/	/																				
	_x__	Stop interval selection at the home position return Set a stop interval for the dog type home position return. The digit is enabled only for linear servo motors. 0: 2 ¹³ (= 8192) pulses 1: 2 ¹⁷ (= 131072) pulses 2: 2 ¹⁸ (= 262144) pulses 3: 2 ²⁰ (= 1048576) pulses 4: 2 ²² (= 4194304) pulses 5: 2 ²⁴ (= 16777216) pulses 6: 2 ²⁶ (= 67108864) pulses	3h	○	○	/																				
	x___	For manufacturer setting	0h	/	/	/																				
PL02 *LIM Linear encoder resolution - Numerator	/	Set a linear encoder resolution with the settings of [Pr. PL02] and [Pr. PL03]. Set the numerator in [Pr. PL02]. This is enabled only for linear servo motors. Setting range: 1 to 65535	1000 [μm]	○	○	/																				
PL03 *LID Linear encoder resolution - Denominator	/	Set a linear encoder resolution with the settings of [Pr. PL02] and [Pr. PL03]. Set the denominator in [Pr. PL03]. This is enabled only for linear servo motors. Setting range: 1 to 65535	1000 [μm]	○	○	/																				
PL04 *LIT2 Linear servo motor/DD motor function selection 2	___x	[AL. 42 Servo control error] detection function selection Refer to the following table.	3h	○	○	○																				
		<table border="1" style="width: 100%; border-collapse: collapse; text-align: center;"> <thead> <tr> <th>Setting value</th> <th>Thrust/torque deviation error (Note)</th> <th>Speed deviation error (Note)</th> <th>Position deviation error (Note)</th> </tr> </thead> <tbody> <tr> <td>0</td> <td rowspan="3">Disabled</td> <td rowspan="2">Disabled</td> <td>Disabled</td> </tr> <tr> <td>1</td> <td>Enabled</td> </tr> <tr> <td>2</td> <td rowspan="2">Enabled</td> <td>Disabled</td> </tr> <tr> <td>3</td> <td>Enabled</td> </tr> <tr> <td>4</td> <td rowspan="4">Enabled</td> <td rowspan="2">Disabled</td> <td>Disabled</td> </tr> <tr> <td>5</td> <td>Enabled</td> </tr> <tr> <td>6</td> <td rowspan="2">Enabled</td> <td>Disabled</td> </tr> <tr> <td>7</td> <td>Enabled</td> </tr> </tbody> </table> <p>Note. For the details of each deviation error, refer to chapter 15 and 16 of "MR-J4- A (-RJ) Servo Amplifier Instruction Manual".</p>					Setting value	Thrust/torque deviation error (Note)	Speed deviation error (Note)	Position deviation error (Note)	0	Disabled	Disabled	Disabled	1	Enabled	2	Enabled	Disabled	3	Enabled	4	Enabled	Disabled	Disabled	5
Setting value	Thrust/torque deviation error (Note)	Speed deviation error (Note)	Position deviation error (Note)																							
0	Disabled	Disabled	Disabled																							
1			Enabled																							
2		Enabled	Disabled																							
3	Enabled																									
4	Enabled	Disabled	Disabled																							
5			Enabled																							
6		Enabled	Disabled																							
7			Enabled																							

7. PARAMETERS

No./ symbol/name	Setting digit	Function	Initial value [unit]	Control mode		
				CP/BCD	CL	PS
PL04 *LIT2 Linear servo motor/DD motor function selection 2	___x__	For manufacturer setting	0h	<input type="checkbox"/>	<input type="checkbox"/>	<input type="checkbox"/>
	_x___		0h	<input type="checkbox"/>	<input type="checkbox"/>	<input type="checkbox"/>
	x____	[AL. 42 Servo control error] detection function controller reset condition selection 0: Reset disabled (reset by powering off/on enabled) 1: Reset enabled	0h	<input type="checkbox"/>	<input type="checkbox"/>	<input type="checkbox"/>
PL05 LB1 Position deviation error detection level		Set a position deviation error detection level of the servo control error detection. When the deviation between a model feedback position and actual feedback position is larger than the setting value, [AL. 42 Servo control error] will occur. However, when "0" is set, the level varies depending on the operation mode in [Pr. PA01]. Linear servo motor: 50 mm Direct drive motor: 0.09 rev Setting range: 0 to 1000	0 [mm]/ [0.01 rev]	<input type="checkbox"/>	<input type="checkbox"/>	<input type="checkbox"/>
PL06 LB2 Speed deviation error detection level		Set a speed deviation error detection level of the servo control error detection. When the deviation between a model feedback speed and actual feedback speed is larger than the setting value, [AL. 42 Servo control error] will occur. However, when "0" is set, the level varies depending on the operation mode in [Pr. PA01]. Linear servo motor: 1000 mm/s Direct drive motor: 100 r/min Setting range: 0 to 5000	0 [mm/s]/ [r/min]	<input type="checkbox"/>	<input type="checkbox"/>	<input type="checkbox"/>
PL07 LB3 Torque/thrust deviation error detection level		Set a torque/thrust deviation error detection level of the servo control error detection. When the deviation between a current command and current feedback is larger than the setting value, [AL. 42.3 Servo control error by torque/thrust deviation] will occur. Setting range: 0 to 1000	100 [%]	<input type="checkbox"/>	<input type="checkbox"/>	<input type="checkbox"/>
PL08 *LIT3 Linear servo motor/DD motor function selection 3	___x__	Magnetic pole detection method selection 0: Position detection method 4: Minute position detection method	0h	<input type="checkbox"/>	<input type="checkbox"/>	<input type="checkbox"/>
	___x__	For manufacturer setting	1h	<input type="checkbox"/>	<input type="checkbox"/>	<input type="checkbox"/>
	_x___	Magnetic pole detection - Stroke limit enabled/disabled selection 0: Enabled 1: Disabled	0h	<input type="checkbox"/>	<input type="checkbox"/>	<input type="checkbox"/>
	x____	For manufacturer setting	0h	<input type="checkbox"/>	<input type="checkbox"/>	<input type="checkbox"/>
PL09 LPWM Magnetic pole detection voltage level		Set a direct current exciting voltage level during the magnetic pole detection. If [AL. 32 Overcurrent], [AL. 50 Overload 1], or [AL. 51 Overload 2] occurs during the magnetic pole detection, decrease the setting value. If [AL. 27 Initial magnetic pole detection error] occurs during the magnetic pole detection, increase the setting value. Setting range: 0 to 100	30 [%]	<input type="checkbox"/>	<input type="checkbox"/>	<input type="checkbox"/>
PL17 LTSTS Magnetic pole detection - Minute position detection method - Function selection	___x__	Response selection Set a response of the minute position detection method. When reducing a travel distance at the magnetic pole detection, increase the setting value. Refer to table 7.12 for settings.	0h	<input type="checkbox"/>	<input type="checkbox"/>	<input type="checkbox"/>
	__x__	Load to motor mass ratio/load to motor inertia ratio selection Select a load to mass of the linear servo motor primary-side ratio or load to mass of the direct drive motor inertia ratio used at the minute position detection method. Set a closest value to the actual load. Refer to table 7.13 for settings.	0h	<input type="checkbox"/>	<input type="checkbox"/>	<input type="checkbox"/>
	_x___	For manufacturer setting	0h	<input type="checkbox"/>	<input type="checkbox"/>	<input type="checkbox"/>
	x____		0h	<input type="checkbox"/>	<input type="checkbox"/>	<input type="checkbox"/>

7. PARAMETERS

No./ symbol/name	Setting digit	Function	Initial value [unit]	Control mode																																																														
				CP/BCD	CL	PS																																																												
PL17 LTSTS Magnetic pole detection - Minute position detection method - Function selection		<p>Table 7.12 Response of minute position detection method at magnetic pole detection</p> <table border="1"> <thead> <tr> <th>Setting value</th> <th>Response</th> <th>Setting value</th> <th>Response</th> </tr> </thead> <tbody> <tr> <td>___0</td> <td rowspan="6">Low response ↑ ↓ Middle response</td> <td>___8</td> <td rowspan="6">Middle response ↑ ↓ High response</td> </tr> <tr> <td>___1</td> <td>___9</td> </tr> <tr> <td>___2</td> <td>___A</td> </tr> <tr> <td>___3</td> <td>___B</td> </tr> <tr> <td>___4</td> <td>___C</td> </tr> <tr> <td>___5</td> <td>___D</td> </tr> <tr> <td>___6</td> <td>___E</td> <td>___F</td> </tr> <tr> <td>___7</td> <td>Middle response</td> <td>High response</td> </tr> </tbody> </table> <p>Table 7.13 Load to motor mass ratio/load to motor inertia ratio</p> <table border="1"> <thead> <tr> <th>Setting value</th> <th>Load to motor mass ratio/load to motor inertia ratio</th> <th>Setting value</th> <th>Load to motor mass ratio/load to motor inertia ratio</th> </tr> </thead> <tbody> <tr> <td>__0__</td> <td>10 times or less</td> <td>__8__</td> <td>80 times</td> </tr> <tr> <td>__1__</td> <td>10 times</td> <td>__9__</td> <td>90 times</td> </tr> <tr> <td>__2__</td> <td>20 times</td> <td>__A__</td> <td>100 times</td> </tr> <tr> <td>__3__</td> <td>30 times</td> <td>__B__</td> <td>110 times</td> </tr> <tr> <td>__4__</td> <td>40 times</td> <td>__C__</td> <td>120 times</td> </tr> <tr> <td>__5__</td> <td>50 times</td> <td>__D__</td> <td>130 times</td> </tr> <tr> <td>__6__</td> <td>60 times</td> <td>__E__</td> <td>140 times</td> </tr> <tr> <td>__7__</td> <td>70 times</td> <td>__F__</td> <td>150 times or more</td> </tr> </tbody> </table>	Setting value	Response	Setting value	Response	___0	Low response ↑ ↓ Middle response	___8	Middle response ↑ ↓ High response	___1	___9	___2	___A	___3	___B	___4	___C	___5	___D	___6	___E	___F	___7	Middle response	High response	Setting value	Load to motor mass ratio/load to motor inertia ratio	Setting value	Load to motor mass ratio/load to motor inertia ratio	__0__	10 times or less	__8__	80 times	__1__	10 times	__9__	90 times	__2__	20 times	__A__	100 times	__3__	30 times	__B__	110 times	__4__	40 times	__C__	120 times	__5__	50 times	__D__	130 times	__6__	60 times	__E__	140 times	__7__	70 times	__F__	150 times or more		<input type="radio"/>	<input type="radio"/>	<input type="radio"/>
Setting value	Response	Setting value	Response																																																															
___0	Low response ↑ ↓ Middle response	___8	Middle response ↑ ↓ High response																																																															
___1		___9																																																																
___2		___A																																																																
___3		___B																																																																
___4		___C																																																																
___5		___D																																																																
___6	___E	___F																																																																
___7	Middle response	High response																																																																
Setting value	Load to motor mass ratio/load to motor inertia ratio	Setting value	Load to motor mass ratio/load to motor inertia ratio																																																															
__0__	10 times or less	__8__	80 times																																																															
__1__	10 times	__9__	90 times																																																															
__2__	20 times	__A__	100 times																																																															
__3__	30 times	__B__	110 times																																																															
__4__	40 times	__C__	120 times																																																															
__5__	50 times	__D__	130 times																																																															
__6__	60 times	__E__	140 times																																																															
__7__	70 times	__F__	150 times or more																																																															
PL18 IDLV Magnetic pole detection - Minute position detection method - Identification signal amplitude		<p>Set an identification signal amplitude used in the minute position detection method. This parameter is enabled only when the magnetic pole detection is the minute position detection method. However, setting "0" will be 100% amplitude.</p> <p>Setting range: 0 to 100</p>	0 [%]	<input type="radio"/>	<input type="radio"/>	<input type="radio"/>																																																												

7.2.8 Option setting parameters ([Pr. Po__])

No./ symbol/name	Setting digit	Function	Initial value [unit]	Control mode		
				CP/BCD	CL	PS
Po02 *ODI1 MR-D01 input device selection 1		Any input device can be assigned to the CN10-21 pin and CN10-26 pin.		<input type="radio"/>	<input type="radio"/>	<input type="radio"/>
	__ x x	<p>CN10-21 selection Select an input signal function of the CN10-21 pin. Refer to table 7.14 for settings. This parameter setting is available with servo amplifiers with software version B7 or later.</p>	02h	<input type="radio"/>	<input type="radio"/>	<input type="radio"/>
	x x __	<p>CN10-26 selection Select an input signal function of the CN10-26 pin. Refer to table 7.14 for settings. This parameter setting is available with servo amplifiers with software version B7 or later.</p>	03h	<input type="radio"/>	<input type="radio"/>	<input type="radio"/>

7. PARAMETERS

No./ symbol/name	Setting digit	Function	Initial value [unit]	Control mode		
				CP/BCD	CL	PS
Po02 *OD11 MR-D01 input device selection 1		Table 7.14 Selectable input devices				
		Setting value	Input device (Note)			
			CP/BCD	CL	PS	
		02	SON	SON	SON	
		03	RES	RES	RES	
		04	PC	PC	PC	
		05	TL	TL	TL	
		06	CR	CR	CR	
		07	ST1	ST1	ST1	
		08	ST2	ST2		
		09	TL1	TL1	TL1	
		0A	LSP	LSP	LSP	
		0B	LSN	LSN	LSN	
		0D	CDP	CDP	CDP	
		0F	MECR	MECR		
		12	MSD	MSD		
		1E	CLTC	CLTC		
		1F	CPCD	CPCD		
		20	MD0	MD0	MD0	
		21	CAMC	CAMC	MD1	
		23	TCH			
		24	TP0	TP0		
		25	TP1	TP1		
		26	OVR	OVR		
		27	TSTP	TSTP		
		29	CI0	CI0		
		2A	CI1	CI1		
		2B	DOG	DOG	SIG	
		2C	SPD1			
		2D	SPD2			
		2E	SPD3			
		2F	SPD4			
		30		LPS		
		31	CI2	CI2	RT	
		32			RTCDP	
		34		PI1	OV0	
		35		PI2	OV1	
		36		PI3	OV2	
		37	CI3	CI3	OV3	
		38	DI0	DI0	DI0	
		39	DI1	DI1	DI1	
		3A	DI2	DI2	DI2	
		3B	DI3	DI3	DI3	
		3C	DI4	DI4	DI4	
		3D	DI5	DI5	DI5	
		3E	DI6	DI6	DI6	
		3F	DI7	DI7	DI7	
<p>Note. CP: Positioning mode (point table method) BCD: Positioning mode (point table method in the BCD input positioning operation) CL: Positioning mode (program method) PS: Positioning mode (indexer method) The diagonal lines indicate manufacturer settings. Never change the setting.</p>						

7. PARAMETERS

No./ symbol/name	Setting digit	Function	Initial value [unit]	Control mode		
				CP/BCD	CL	PS
Po03 *ODI2 MR-D01 input device selection 2	Any input device can be assigned to the CN10-27 pin and CN10-28 pin.					
	__ x x	CN10-27 selection Select an input signal function of the CN10-27 pin. Refer to table 7.14 in [Pr. Po02] for setting values. This parameter setting is available with servo amplifiers with software version B7 or later.	05h	<input type="radio"/>	<input type="radio"/>	<input type="radio"/>
	x x __	CN10-28 selection Select an input signal function of the CN10-28 pin. Refer to table 7.14 in [Pr. Po02] for setting values. This parameter setting is available with servo amplifiers with software version B7 or later.	09h	<input type="radio"/>	<input type="radio"/>	<input type="radio"/>
Po04 *ODI3 MR-D01 input device selection 3	Any input device can be assigned to the CN10-29 pin and CN10-30 pin.					
	__ x x	CN10-28 selection Select an input signal function of the CN10-28 pin. Refer to table 7.14 in [Pr. Po02] for setting values. This parameter setting is available with servo amplifiers with software version B7 or later.	24h	<input type="radio"/>	<input type="radio"/>	<input type="radio"/>
	x x __	CN10-30 selection Select an input signal function of the CN10-30 pin. Refer to table 7.14 in [Pr. Po02] for setting values. This parameter setting is available with servo amplifiers with software version B7 or later.	25h	<input type="radio"/>	<input type="radio"/>	<input type="radio"/>
Po05 *ODI4 MR-D01 input device selection 4	Any input device can be assigned to the CN10-31 pin and CN10-32 pin.					
	__ x x	CN10-31 selection Select an input signal function of the CN10-31 pin. Refer to table 7.14 in [Pr. Po02] for setting values. This parameter setting is available with servo amplifiers with software version B7 or later.	26h	<input type="radio"/>	<input type="radio"/>	<input type="radio"/>
	x x __	CN10-32 selection Select an input signal function of the CN10-32 pin. Refer to table 7.14 in [Pr. Po02] for setting values. This parameter setting is available with servo amplifiers with software version B7 or later.	20h	<input type="radio"/>	<input type="radio"/>	<input type="radio"/>
Po06 *ODI5 MR-D01 input device selection 5	Any input device can be assigned to the CN10-33 pin and CN10-34 pin.					
	__ x x	CN10-33 selection Select an input signal function of the CN10-33 pin. Refer to table 7.14 in [Pr. Po02] for setting values. This parameter setting is available with servo amplifiers with software version B7 or later.	27h	<input type="radio"/>	<input type="radio"/>	<input type="radio"/>
	x x __	CN10-34 selection Select an input signal function of the CN10-34 pin. Refer to table 7.14 in [Pr. Po02] for setting values. This parameter setting is available with servo amplifiers with software version B7 or later.	04h	<input type="radio"/>	<input type="radio"/>	<input type="radio"/>
Po07 *ODI6 MR-D01 input device selection 6	Any input device can be assigned to the CN10-35 pin and CN10-36 pin.					
	__ x x	CN10-35 selection Select an input signal function of the CN10-35 pin. Refer to table 7.14 in [Pr. Po02] for setting values. This parameter setting is available with servo amplifiers with software version B7 or later.	07h	<input type="radio"/>	<input type="radio"/>	<input type="radio"/>
	x x __	CN10-36 selection Select an input signal function of the CN10-36 pin. Refer to table 7.14 in [Pr. Po02] for setting values. This parameter setting is available with servo amplifiers with software version B7 or later.	08h	<input type="radio"/>	<input type="radio"/>	<input type="radio"/>

7. PARAMETERS

No./ symbol/name	Setting digit	Function	Initial value [unit]	Control mode		
				CP/BCD	CF	PS
Po08		Any output device can be assigned to the CN10-46 pin and CN10-47 pin.				
*ODO1 MR-D01 output device selection 1	__ x x	CN10-46 selection Select an output signal function of the CN10-46 pin. Refer to table 7.15 for settings. This parameter setting is available with servo amplifiers with software version B7 or later.	26h	<input type="radio"/>	<input type="radio"/>	<input type="radio"/>
	x x __	CN10-47 selection Select an output signal function of the CN10-47 pin. Refer to table 7.15 for settings. This parameter setting is available with servo amplifiers with software version B7 or later.	27h	<input type="radio"/>	<input type="radio"/>	<input type="radio"/>

7. PARAMETERS

No./ symbol/name	Setting digit	Function	Initial value [unit]	Control mode																																																																																																																																																																															
				CP/BCD	CL	PS																																																																																																																																																																													
Po08 *ODO1 MR-D01 output device selection 1		Table 7.15 Selectable output devices																																																																																																																																																																																	
		<table border="1"> <thead> <tr> <th rowspan="2">Setting value</th> <th colspan="3">Output device (Note)</th> </tr> <tr> <th>CP/BCD</th> <th>CL</th> <th>PS</th> </tr> </thead> <tbody> <tr><td>00</td><td>Always off</td><td>Always off</td><td>Always off</td></tr> <tr><td>02</td><td>RD</td><td>RD</td><td>RD</td></tr> <tr><td>03</td><td>ALM</td><td>ALM</td><td>ALM</td></tr> <tr><td>04</td><td>INP</td><td>INP</td><td>INP</td></tr> <tr><td>05</td><td>MBR</td><td>MBR</td><td>MBR</td></tr> <tr><td>06</td><td>DB</td><td>DB</td><td>DB</td></tr> <tr><td>07</td><td>TLC</td><td>TLC</td><td>TLC</td></tr> <tr><td>08</td><td>WNG</td><td>WNG</td><td>WNG</td></tr> <tr><td>09</td><td>BWNG</td><td>BWNG</td><td>BWNG</td></tr> <tr><td>0A</td><td>SA</td><td>SA</td><td>Always off</td></tr> <tr><td>0B</td><td>Always off</td><td>Always off</td><td>Always off</td></tr> <tr><td>0C</td><td>ZSP</td><td>ZSP</td><td>ZSP</td></tr> <tr><td>0D</td><td>MTTR</td><td>MTTR</td><td>MTTR</td></tr> <tr><td>0F</td><td>CDPS</td><td>CDPS</td><td>CDPS</td></tr> <tr><td>10</td><td>CDLS</td><td>CDLS</td><td>CDLS</td></tr> <tr><td>11</td><td>ABSV</td><td>ABSV</td><td>ABSV</td></tr> <tr><td>1F</td><td>CPCC</td><td>CPCC</td><td style="text-align: center;">/</td></tr> <tr><td>23</td><td>CPO</td><td>CPO</td><td>CPO</td></tr> <tr><td>24</td><td>ZP</td><td>ZP</td><td>ZP</td></tr> <tr><td>25</td><td>POT</td><td>POT</td><td>Always off</td></tr> <tr><td>26</td><td>PUS</td><td>PUS</td><td>Always off</td></tr> <tr><td>27</td><td>MEND</td><td>MEND</td><td>MEND</td></tr> <tr><td>29</td><td>CLTS</td><td>CLTS</td><td style="text-align: center;">/</td></tr> <tr><td>2B</td><td>CLTSM</td><td>CLTSM</td><td style="text-align: center;">/</td></tr> <tr><td>2C</td><td>PED</td><td>PED</td><td style="text-align: center;">/</td></tr> <tr><td>2D</td><td style="text-align: center;">/</td><td>SOUT</td><td style="text-align: center;">/</td></tr> <tr><td>2E</td><td style="text-align: center;">/</td><td>OUT1</td><td style="text-align: center;">/</td></tr> <tr><td>2F</td><td style="text-align: center;">/</td><td>OUT2</td><td style="text-align: center;">/</td></tr> <tr><td>30</td><td style="text-align: center;">/</td><td>OUT3</td><td style="text-align: center;">/</td></tr> <tr><td>31</td><td>ALMWNG</td><td>ALMWNG</td><td>ALMWNG</td></tr> <tr><td>32</td><td>BW9F</td><td>BW9F</td><td>BW9F</td></tr> <tr><td>33</td><td>MSDH</td><td>MSDH</td><td style="text-align: center;">/</td></tr> <tr><td>34</td><td>MSDL</td><td>MSDL</td><td style="text-align: center;">/</td></tr> <tr><td>37</td><td>CAMS</td><td>CAMS</td><td style="text-align: center;">/</td></tr> <tr><td>38</td><td>PT0</td><td style="text-align: center;">/</td><td>PS0</td></tr> <tr><td>39</td><td>PT1</td><td style="text-align: center;">/</td><td>PS1</td></tr> <tr><td>3A</td><td>PT2</td><td style="text-align: center;">/</td><td>PS2</td></tr> <tr><td>3B</td><td>PT3</td><td style="text-align: center;">/</td><td>PS3</td></tr> <tr><td>3C</td><td>PT4</td><td style="text-align: center;">/</td><td>PS4</td></tr> <tr><td>3D</td><td>PT5</td><td style="text-align: center;">/</td><td>PS5</td></tr> <tr><td>3E</td><td>PT6</td><td style="text-align: center;">/</td><td>PS6</td></tr> <tr><td>3F</td><td>PT7</td><td style="text-align: center;">/</td><td>PS7</td></tr> </tbody> </table>	Setting value	Output device (Note)			CP/BCD	CL	PS	00	Always off	Always off	Always off	02	RD	RD	RD	03	ALM	ALM	ALM	04	INP	INP	INP	05	MBR	MBR	MBR	06	DB	DB	DB	07	TLC	TLC	TLC	08	WNG	WNG	WNG	09	BWNG	BWNG	BWNG	0A	SA	SA	Always off	0B	Always off	Always off	Always off	0C	ZSP	ZSP	ZSP	0D	MTTR	MTTR	MTTR	0F	CDPS	CDPS	CDPS	10	CDLS	CDLS	CDLS	11	ABSV	ABSV	ABSV	1F	CPCC	CPCC	/	23	CPO	CPO	CPO	24	ZP	ZP	ZP	25	POT	POT	Always off	26	PUS	PUS	Always off	27	MEND	MEND	MEND	29	CLTS	CLTS	/	2B	CLTSM	CLTSM	/	2C	PED	PED	/	2D	/	SOUT	/	2E	/	OUT1	/	2F	/	OUT2	/	30	/	OUT3	/	31	ALMWNG	ALMWNG	ALMWNG	32	BW9F	BW9F	BW9F	33	MSDH	MSDH	/	34	MSDL	MSDL	/	37	CAMS	CAMS	/	38	PT0	/	PS0	39	PT1	/	PS1	3A	PT2	/	PS2	3B	PT3	/	PS3	3C	PT4	/	PS4	3D	PT5	/	PS5	3E	PT6	/	PS6	3F	PT7	/	PS7		
Setting value	Output device (Note)																																																																																																																																																																																		
	CP/BCD	CL	PS																																																																																																																																																																																
00	Always off	Always off	Always off																																																																																																																																																																																
02	RD	RD	RD																																																																																																																																																																																
03	ALM	ALM	ALM																																																																																																																																																																																
04	INP	INP	INP																																																																																																																																																																																
05	MBR	MBR	MBR																																																																																																																																																																																
06	DB	DB	DB																																																																																																																																																																																
07	TLC	TLC	TLC																																																																																																																																																																																
08	WNG	WNG	WNG																																																																																																																																																																																
09	BWNG	BWNG	BWNG																																																																																																																																																																																
0A	SA	SA	Always off																																																																																																																																																																																
0B	Always off	Always off	Always off																																																																																																																																																																																
0C	ZSP	ZSP	ZSP																																																																																																																																																																																
0D	MTTR	MTTR	MTTR																																																																																																																																																																																
0F	CDPS	CDPS	CDPS																																																																																																																																																																																
10	CDLS	CDLS	CDLS																																																																																																																																																																																
11	ABSV	ABSV	ABSV																																																																																																																																																																																
1F	CPCC	CPCC	/																																																																																																																																																																																
23	CPO	CPO	CPO																																																																																																																																																																																
24	ZP	ZP	ZP																																																																																																																																																																																
25	POT	POT	Always off																																																																																																																																																																																
26	PUS	PUS	Always off																																																																																																																																																																																
27	MEND	MEND	MEND																																																																																																																																																																																
29	CLTS	CLTS	/																																																																																																																																																																																
2B	CLTSM	CLTSM	/																																																																																																																																																																																
2C	PED	PED	/																																																																																																																																																																																
2D	/	SOUT	/																																																																																																																																																																																
2E	/	OUT1	/																																																																																																																																																																																
2F	/	OUT2	/																																																																																																																																																																																
30	/	OUT3	/																																																																																																																																																																																
31	ALMWNG	ALMWNG	ALMWNG																																																																																																																																																																																
32	BW9F	BW9F	BW9F																																																																																																																																																																																
33	MSDH	MSDH	/																																																																																																																																																																																
34	MSDL	MSDL	/																																																																																																																																																																																
37	CAMS	CAMS	/																																																																																																																																																																																
38	PT0	/	PS0																																																																																																																																																																																
39	PT1	/	PS1																																																																																																																																																																																
3A	PT2	/	PS2																																																																																																																																																																																
3B	PT3	/	PS3																																																																																																																																																																																
3C	PT4	/	PS4																																																																																																																																																																																
3D	PT5	/	PS5																																																																																																																																																																																
3E	PT6	/	PS6																																																																																																																																																																																
3F	PT7	/	PS7																																																																																																																																																																																
		<p>Note. CP: Positioning mode (point table method) BCD: Positioning mode (point table method in the BCD input positioning operation) CL: Positioning mode (program method) PS: Positioning mode (indexer method) The diagonal lines indicate manufacturer settings. Never change the setting.</p>																																																																																																																																																																																	

7. PARAMETERS

No./ symbol/name	Setting digit	Function	Initial value [unit]	Control mode		
				CP/BCD	CL	PS
Po09 *ODO9 MR-D01 output device selection 2	Any output device can be assigned to the CN10-48 pin and CN10-49 pin.					
	__ x x	CN10-48 selection Select an output signal function of the CN10-48 pin. Refer to table 7.15 in [Pr. Po08] for settings. This parameter setting is available with servo amplifiers with software version B7 or later.	23h	○	○	○
	x x __	CN10-49 selection Select an output signal function of the CN10-49 pin. Refer to table 7.15 in [Pr. Po08] for settings. This parameter setting is available with servo amplifiers with software version B7 or later.	04h	○	○	○
Po10 *OOP1 Function selection O-1	Always set this parameter when using MR-D01. Set the MR-D01 input device selection, select whether to enable or disable position data input signs, and set a data establishment condition.					
	___ x	MR-D01 DI0 to DI14 input signal device selection 0: Disabled 1: Point table: 255 points 2: BCD 3 digits × 2 inputs This parameter setting is available with servo amplifiers with software version B7 or later.	1h	○	○	○
	__ x _	For manufacturer setting	0h	△	△	△
	_ x _ _	MR-D01 position data input sign +/- 0: Disabled 1: Enabled This parameter setting is available with servo amplifiers with software version B7 or later.	0h	○	○	○
	x _ _ _	MR-D01 data establishment condition 0: Strobe signal enabled (when the PLC is used) 2: 3.55 ms data matching time (Strobe signal disabled) This parameter setting is available with servo amplifiers with software version B7 or later.	2h	○	○	○
Po11 *OOP2 Function selection O-2	Select the input devices of the override input and torque limit.					
	___ x	For manufacturer setting	0h	△	△	△
	__ x _	Override input CN1-2/CN20-2 switching selection 0: CN1-2 pin enabled 1: CN20-2 pin enabled Setting "1" when no MR-D01 has been connected will trigger [AL. 37].	0h	○	○	○
	_ x _ _	Torque limit CN1-27/CN20-12 switching selection 0: CN1-27 pin enabled 1: CN20-12 pin enabled Setting "1" when no MR-D01 has been connected will trigger [AL. 37].	0h	○	○	○
	x _ _ _	For manufacturer setting	0h	△	△	△
Po12 *OOP3 Function selection O-3	Select an alarm code output setting and an M code output setting.					
	___ x	MR-D01 alarm code output 0: Disabled 1: Enabled Selecting "1" in this digit will output an alarm code when an alarm occurs. This parameter setting is available with servo amplifiers with software version B7 or later.	0h	○	○	○
	__ x _	M code output selection 0: Disabled 1: Enabled Selecting "1" in this digit will enable you to check outputs according to M codes (0 to 99) set with point tables by using output devices of the communication function.	0h	○	△	△
	_ x _ _	For manufacturer setting	0h	△	△	△
	x _ _ _	For manufacturer setting	0h	△	△	△

7. PARAMETERS

No./ symbol/name	Setting digit	Function	Initial value [unit]	Control mode																																																																																																																																																						
				CP/BCD	CL	PS																																																																																																																																																				
Po13 *OMOD1 MR-D01 analog monitor 1 output selection	Set a signal to output to Analog monitor 1.																																																																																																																																																									
	__ x x	Analog monitor 1 output selection Refer to table 7.16 for settings. This parameter setting is available with servo amplifiers with software version B7 or later.	00h	○	○	○																																																																																																																																																				
	_ x _ _	For manufacturer setting	0h	△	△	△																																																																																																																																																				
	x _ _ _		0h	△	△	△																																																																																																																																																				
Table 7.16 Analog monitor setting value																																																																																																																																																										
<table border="1"> <thead> <tr> <th rowspan="2">Setting value</th> <th rowspan="2">Item</th> <th colspan="4">Operation mode (Note 1)</th> </tr> <tr> <th>Standard</th> <th>Full.</th> <th>Lin.</th> <th>DD</th> </tr> </thead> <tbody> <tr> <td>__ 0 0</td> <td>(Linear) servo motor speed (±8 V/max. speed)</td> <td>○</td> <td>○</td> <td>○</td> <td>○</td> </tr> <tr> <td>__ 0 1</td> <td>Torque or thrust (±8 V/max. torque or max. thrust) (Note 3)</td> <td>○</td> <td>○</td> <td>○</td> <td>○</td> </tr> <tr> <td>__ 0 2</td> <td>(Linear) servo motor speed (+8 V/max. speed)</td> <td>○</td> <td>○</td> <td>○</td> <td>○</td> </tr> <tr> <td>__ 0 3</td> <td>Torque or thrust (+8 V/max. torque or max. thrust) (Note 3)</td> <td>○</td> <td>○</td> <td>○</td> <td>○</td> </tr> <tr> <td>__ 0 4</td> <td>Current command (±8 V/max. current command)</td> <td>○</td> <td>○</td> <td>○</td> <td>○</td> </tr> <tr> <td>__ 0 5</td> <td>Command pulse frequency (±10 V/±4 Mpulses/s)</td> <td>○</td> <td>○</td> <td>○</td> <td>○</td> </tr> <tr> <td>__ 0 6</td> <td>Servo motor-side droop pulses (±10 V/100 pulses) (Note 2)</td> <td>○</td> <td>○</td> <td>○</td> <td>○</td> </tr> <tr> <td>__ 0 7</td> <td>Servo motor-side droop pulses (±10 V/1000 pulses) (Note 2)</td> <td>○</td> <td>○</td> <td>○</td> <td>○</td> </tr> <tr> <td>__ 0 8</td> <td>Servo motor-side droop pulses (±10 V/10000 pulses) (Note 2)</td> <td>○</td> <td>○</td> <td>○</td> <td>○</td> </tr> <tr> <td>__ 0 9</td> <td>Servo motor-side droop pulses (±10 V/100000 pulses) (Note 2)</td> <td>○</td> <td>○</td> <td>○</td> <td>○</td> </tr> <tr> <td>__ 0 A</td> <td>Feedback position (±10 V/1 Mpulses) (Note 2)</td> <td>○</td> <td>△</td> <td>△</td> <td>△</td> </tr> <tr> <td>__ 0 B</td> <td>Feedback position (±10 V/10 Mpulses) (Note 2)</td> <td>○</td> <td>△</td> <td>△</td> <td>△</td> </tr> <tr> <td>__ 0 C</td> <td>Feedback position (±10 V/100 Mpulses) (Note 2)</td> <td>○</td> <td>△</td> <td>△</td> <td>△</td> </tr> <tr> <td>__ 0 D</td> <td>Bus voltage (200 V class and 100 V class: +8 V/400 V, 400 V class: +8 V/800 V)</td> <td>○</td> <td>○</td> <td>○</td> <td>○</td> </tr> <tr> <td>__ 0 E</td> <td>Speed command 2 (±8 V/max. speed)</td> <td>○</td> <td>○</td> <td>○</td> <td>○</td> </tr> <tr> <td>__ 1 0</td> <td>Load-side droop pulses (±10 V/100 pulses) (Note 2)</td> <td>△</td> <td>○</td> <td>△</td> <td>△</td> </tr> <tr> <td>__ 1 1</td> <td>Load-side droop pulses (±10 V/1000 pulses) (Note 2)</td> <td>△</td> <td>○</td> <td>△</td> <td>△</td> </tr> <tr> <td>__ 1 2</td> <td>Load-side droop pulses (±10 V/10000 pulses) (Note 2)</td> <td>△</td> <td>○</td> <td>△</td> <td>△</td> </tr> <tr> <td>__ 1 3</td> <td>Load-side droop pulses (±10 V/100000 pulses) (Note 2)</td> <td>△</td> <td>○</td> <td>△</td> <td>△</td> </tr> <tr> <td>__ 1 4</td> <td>Load-side droop pulses (±10 V/1M pulses) (Note 2)</td> <td>△</td> <td>○</td> <td>△</td> <td>△</td> </tr> <tr> <td>__ 1 5</td> <td>Servo motor-side/load-side position deviation (±10 V/100000 pulses)</td> <td>△</td> <td>○</td> <td>△</td> <td>△</td> </tr> <tr> <td>__ 1 6</td> <td>Servo motor-side/load-side speed deviation (±8 V/max. speed)</td> <td>△</td> <td>○</td> <td>△</td> <td>△</td> </tr> <tr> <td>__ 1 7</td> <td>Internal temperature of encoder (±10 V/±128 °C)</td> <td>○</td> <td>○</td> <td>△</td> <td>○</td> </tr> </tbody> </table>							Setting value	Item	Operation mode (Note 1)				Standard	Full.	Lin.	DD	__ 0 0	(Linear) servo motor speed (±8 V/max. speed)	○	○	○	○	__ 0 1	Torque or thrust (±8 V/max. torque or max. thrust) (Note 3)	○	○	○	○	__ 0 2	(Linear) servo motor speed (+8 V/max. speed)	○	○	○	○	__ 0 3	Torque or thrust (+8 V/max. torque or max. thrust) (Note 3)	○	○	○	○	__ 0 4	Current command (±8 V/max. current command)	○	○	○	○	__ 0 5	Command pulse frequency (±10 V/±4 Mpulses/s)	○	○	○	○	__ 0 6	Servo motor-side droop pulses (±10 V/100 pulses) (Note 2)	○	○	○	○	__ 0 7	Servo motor-side droop pulses (±10 V/1000 pulses) (Note 2)	○	○	○	○	__ 0 8	Servo motor-side droop pulses (±10 V/10000 pulses) (Note 2)	○	○	○	○	__ 0 9	Servo motor-side droop pulses (±10 V/100000 pulses) (Note 2)	○	○	○	○	__ 0 A	Feedback position (±10 V/1 Mpulses) (Note 2)	○	△	△	△	__ 0 B	Feedback position (±10 V/10 Mpulses) (Note 2)	○	△	△	△	__ 0 C	Feedback position (±10 V/100 Mpulses) (Note 2)	○	△	△	△	__ 0 D	Bus voltage (200 V class and 100 V class: +8 V/400 V, 400 V class: +8 V/800 V)	○	○	○	○	__ 0 E	Speed command 2 (±8 V/max. speed)	○	○	○	○	__ 1 0	Load-side droop pulses (±10 V/100 pulses) (Note 2)	△	○	△	△	__ 1 1	Load-side droop pulses (±10 V/1000 pulses) (Note 2)	△	○	△	△	__ 1 2	Load-side droop pulses (±10 V/10000 pulses) (Note 2)	△	○	△	△	__ 1 3	Load-side droop pulses (±10 V/100000 pulses) (Note 2)	△	○	△	△	__ 1 4	Load-side droop pulses (±10 V/1M pulses) (Note 2)	△	○	△	△	__ 1 5	Servo motor-side/load-side position deviation (±10 V/100000 pulses)	△	○	△	△	__ 1 6	Servo motor-side/load-side speed deviation (±8 V/max. speed)	△	○	△	△	__ 1 7	Internal temperature of encoder (±10 V/±128 °C)	○	○	△	○
Setting value	Item	Operation mode (Note 1)																																																																																																																																																								
		Standard	Full.	Lin.	DD																																																																																																																																																					
__ 0 0	(Linear) servo motor speed (±8 V/max. speed)	○	○	○	○																																																																																																																																																					
__ 0 1	Torque or thrust (±8 V/max. torque or max. thrust) (Note 3)	○	○	○	○																																																																																																																																																					
__ 0 2	(Linear) servo motor speed (+8 V/max. speed)	○	○	○	○																																																																																																																																																					
__ 0 3	Torque or thrust (+8 V/max. torque or max. thrust) (Note 3)	○	○	○	○																																																																																																																																																					
__ 0 4	Current command (±8 V/max. current command)	○	○	○	○																																																																																																																																																					
__ 0 5	Command pulse frequency (±10 V/±4 Mpulses/s)	○	○	○	○																																																																																																																																																					
__ 0 6	Servo motor-side droop pulses (±10 V/100 pulses) (Note 2)	○	○	○	○																																																																																																																																																					
__ 0 7	Servo motor-side droop pulses (±10 V/1000 pulses) (Note 2)	○	○	○	○																																																																																																																																																					
__ 0 8	Servo motor-side droop pulses (±10 V/10000 pulses) (Note 2)	○	○	○	○																																																																																																																																																					
__ 0 9	Servo motor-side droop pulses (±10 V/100000 pulses) (Note 2)	○	○	○	○																																																																																																																																																					
__ 0 A	Feedback position (±10 V/1 Mpulses) (Note 2)	○	△	△	△																																																																																																																																																					
__ 0 B	Feedback position (±10 V/10 Mpulses) (Note 2)	○	△	△	△																																																																																																																																																					
__ 0 C	Feedback position (±10 V/100 Mpulses) (Note 2)	○	△	△	△																																																																																																																																																					
__ 0 D	Bus voltage (200 V class and 100 V class: +8 V/400 V, 400 V class: +8 V/800 V)	○	○	○	○																																																																																																																																																					
__ 0 E	Speed command 2 (±8 V/max. speed)	○	○	○	○																																																																																																																																																					
__ 1 0	Load-side droop pulses (±10 V/100 pulses) (Note 2)	△	○	△	△																																																																																																																																																					
__ 1 1	Load-side droop pulses (±10 V/1000 pulses) (Note 2)	△	○	△	△																																																																																																																																																					
__ 1 2	Load-side droop pulses (±10 V/10000 pulses) (Note 2)	△	○	△	△																																																																																																																																																					
__ 1 3	Load-side droop pulses (±10 V/100000 pulses) (Note 2)	△	○	△	△																																																																																																																																																					
__ 1 4	Load-side droop pulses (±10 V/1M pulses) (Note 2)	△	○	△	△																																																																																																																																																					
__ 1 5	Servo motor-side/load-side position deviation (±10 V/100000 pulses)	△	○	△	△																																																																																																																																																					
__ 1 6	Servo motor-side/load-side speed deviation (±8 V/max. speed)	△	○	△	△																																																																																																																																																					
__ 1 7	Internal temperature of encoder (±10 V/±128 °C)	○	○	△	○																																																																																																																																																					
<p>Note 1. Items with ○ are available for each operation mode. Standard: Standard (semi closed loop system) use of the rotary servo motor Full.: Fully closed loop system use of the rotary servo motor Lin.: Linear servo motor use DD: Direct drive (DD) motor use</p> <p>2. Encoder pulse unit</p> <p>3. 8 V is outputted at the maximum torque. However, when [Pr. PA11] and [Pr. PA12] are set to limit torque, 8 V is output at the torque highly limited.</p>																																																																																																																																																										

7. PARAMETERS

No./ symbol/name	Setting digit	Function	Initial value [unit]	Control mode		
				CP/BCD	CL	PS
Po14 OMOD2 MR-D01 analog monitor 2 output selection	Set a signal to output to Analog monitor 2.					
	__ x x	Analog monitor 2 output selection Select a signal to output to MO2 (Analog monitor 2). Refer to [Pr. Po13] for settings. This parameter setting is available with servo amplifiers with software version B7 or later.	00h	<input type="radio"/>	<input type="radio"/>	<input type="radio"/>
	__ x __ x ____	For manufacturer setting	0h 0h	<input type="checkbox"/>	<input type="checkbox"/>	<input type="checkbox"/>
Po15 OMO1 MR-D01 analog monitor 1 offset		This is used to set the offset voltage of MO1 (Analog monitor 1). This parameter setting is available with servo amplifiers with software version B7 or later. Setting range: -9999 to 9999	0 [mV]	<input type="radio"/>	<input type="radio"/>	<input type="radio"/>
Po16 OMO2 MR-D01 analog monitor 2 offset		This is used to set the offset voltage of MO2 (Analog monitor 2). This parameter setting is available with servo amplifiers with software version B7 or later. Setting range: -9999 to 9999	0 [mV]	<input type="radio"/>	<input type="radio"/>	<input type="radio"/>
Po21 OVCO MR-D01 override offset		This is used to set the offset voltage of the override. This parameter setting is available with servo amplifiers with software version B7 or later. Setting range: -9999 to 9999	0 [mV]	<input type="radio"/>	<input type="radio"/>	<input type="radio"/>
Po22 OTLO MR-D01 Analog torque limit offset		This is used to set the offset voltage of the analog torque limit. This parameter setting is available with servo amplifiers with software version B7 or later. Setting range: -9999 to 9999	0 [mV]	<input type="radio"/>	<input type="radio"/>	<input type="radio"/>
Po27 *ODI7 MR-D01 input device selection 7	Any input device can be assigned to the CN10-18 pin and CN10-19 pin.					
	__ x x x x __	CN10-18 selection Select an input signal function of the CN10-18 pin. Refer to table 7.14 in [Pr. Po02] for setting values. This parameter setting is available with servo amplifiers with software version B7 or later.	2Ch 2Dh	<input type="radio"/>	<input type="radio"/>	<input type="radio"/>
Po28 *ODI8 MR-D01 input device selection 8	Any input device can be assigned to the CN10-20 pin.					
	__ x x x x __	CN10-20 selection Select an input signal function of the CN10-20 pin. Refer to table 7.14 in [Pr. Po02] for setting values. This parameter setting is available with servo amplifiers with software version B7 or later.	2Eh 00h	<input type="radio"/>	<input type="radio"/>	<input type="radio"/>

7. PARAMETERS

7.2.9 Positioning control parameters ([Pr. PT_ _])

No./ symbol/name	Setting digit	Function	Initial value [unit]	Control mode		
				CP/BCD	CL	P.S
PT01 *CTY Command mode selection	___x	Positioning command method selection 0: Absolute value command method 1: Incremental value command method	0h	○	○	○
	__x_	For manufacturer setting	0h	○	○	○
	_x__	Position data unit 0: mm 1: inch 2: degree 3: pulse	0h	○	○	○
	x___	RS-422 communication - Previous model equivalent selection 0: Disabled (MR-J4 standard) 1: Enabled (equivalent to MR-J3-T) 2: Enabled (equivalent to MR-J2S-CP) 3: Enabled (equivalent to MR-J2S-CL) For the communication command of the Mitsubishi general-purpose AC servo protocol, the status display and read/write commands of input/output devices can be used with the data Nos. and bit assignment of the same as previous models. When this digit is "1" or "2", MR Configurator2 cannot be used with the USB communication.	0h	○	○	○
PT02 *TOP1 Function selection T-1	___x	Follow-up of SON (Servo-on) off/EM2 (Forced stop 2) off with absolute value command method in incremental system 0: Disabled (Home position is erased at servo-off or EM2 off.) 1: Enabled (Home position is not erased even if servo-off, EM2 off, or alarm occurrence which can be canceled with reset. The operation can be continued.)	0h	○	○	○
	__x_	For manufacturer setting	0h	○	○	○
	_x__	For manufacturer setting	0h	○	○	○
	x___	Point table/program writing inhibit 0: Allow 1: Inhibit	0h	○	○	○
PT03 *FTY Feeding function selection	___x	Feed length multiplication [STM] 0: × 1 1: × 10 2: × 100 3: × 1000 This digit will be disabled when [degree] or [pulse] of "Position data unit" is set in [Pr. PT01].	0h	○	○	○
	__x_	Manual pulse generator multiplication 0: × 1 1: × 10 2: × 100	0h	○	○	○
	_x__	Shortest rotation selection per degree 0: Rotation direction specifying 1: Shortest rotation This parameter setting is available with servo amplifiers with software version B7 or later.	0h	○	○	○
	x___	For manufacturer setting	0h	○	○	○

7. PARAMETERS

No./ symbol/name	Setting digit	Function	Initial value [unit]	Control mode		
				CP/BCD	CL	PS
PT04 *ZTY Home position return type	---x	Home position return method 0: Dog type (rear end detection, Z-phase reference)/torque limit changing dog type 1: Count type (front end detection, Z-phase reference) (Note 1) 2: Data set type/torque limit changing data set type 3: Stopper type (Note 1) 4: Home position ignorance (servo-on position as home position) (Note 1) 5: Dog type (rear end detection, rear end reference) (Note 1) 6: Count type (front end detection, front end reference) (Note 1) 7: Dog cradle type (Note 1) 8: Dog type (front end detection, Z-phase reference) (Note 1, 2) 9: Dog type (front end detection, front end reference) (Note 1) A: Dogless type (Z-phase reference) (Note 1, 2) Note 1. Setting "1" and "3" to "A" will trigger [AL. 37 Parameter error] for the indexer method. 2. This type is available when a linear encoder or a DD motor is used with servo amplifiers with software version B7 or later. This type is not available when a linear encoder or a DD motor is not used with servo amplifiers with software version B6 or earlier. Setting this type will trigger [AL. 37 Parameter error].	0h	<input type="radio"/>	<input type="radio"/>	<input type="radio"/>
	--x_	Home position return direction 0: Address increasing direction 1: Address decreasing direction Setting "2" or more to this digit will be recognized as "1: Address decreasing direction".	1h	<input type="radio"/>	<input type="radio"/>	<input type="radio"/>
	_x__	Home position shift distance multiplication Set a multiplication of [Pr. PT07 Home position shift distance]. 0: × 1 1: × 10 2: × 100 3: × 1000 "0" to "3" can be used for the indexer method. When [degree] of "Position data unit" is set in [Pr. PT01] in the point table method or program method, only "0" and "1" are enabled. ("2" or more will be recognized as "1".)	0h	<input type="radio"/>	<input type="radio"/>	<input type="radio"/>
	x___	For manufacturer setting	0h	<input type="radio"/>	<input type="radio"/>	<input type="radio"/>
PT05 ZRF Home position return speed		Set a (linear) servo motor speed at home position return. Setting range: 0 to permissible instantaneous speed	100 [r/min]/ [mm/s]	<input type="radio"/>	<input type="radio"/>	<input type="radio"/>
PT06 CRF Creep speed		Set a creep speed after proximity dog at home position return. Setting range: 0 to permissible instantaneous speed	10 [r/min]/ [mm/s]	<input type="radio"/>	<input type="radio"/>	<input type="radio"/>

7. PARAMETERS

No./ symbol/name	Setting digit	Function	Initial value [unit]	Control mode		
				CP/BCD	CL	PS
PT07 ZST Home position shift distance		<p>Set a shift distance from the Z-phase pulse detection position in the encoder. The unit will be as follows depending on the positioning mode.</p> <ul style="list-style-type: none"> Point table method or program method It will be change to [μm], 10^{-4} [inch], 10^{-3} [degree], or [pulse] with [Pr. PT01]. Indexer method It will be command unit [pulse]. (unit of a load-side rotation expressed by the number of encoder resolution pulses) Refer to the Function column of [Pr. PA10] for the command unit [pulse]. Additionally, when "Home position shift distance multiplication" is set in [Pr. PT04], it is used with "$\times 10^{\text{th}}$". <p>Setting range: 0 to 65535</p>	0 Refer to Function column for unit.	<input type="radio"/>	<input type="radio"/>	<input type="radio"/>
PT08 *ZPS Home position return position data		<p>Set a current position at home position return completion. The unit will be changed to 10^{STM} [μm], $10^{(\text{STM}-4)}$ [inch], 10^{-3} [degree], or [pulse] with the setting of [Pr. PT01]. Additionally, when the following parameters are changed, the home position return position data will be changed. Execute the home position return again.</p> <ul style="list-style-type: none"> "Position data unit" in [Pr. PT01] "Feed length multiplication (STM)" in [Pr. PT03] "Home position return type" in [Pr. PT04] <p>Setting range: -32768 to 32767</p>	0 Refer to Function column for unit.	<input type="radio"/>	<input type="radio"/>	<input type="radio"/>
PT09 DCT Travel distance after proximity dog		<p>Set a travel distance after proximity dog at home position return for the count type, dog type rear end reference, count type front end reference, and dog type front end reference. The unit will be changed to 10^{STM} [μm], $10^{(\text{STM}-4)}$ [inch], 10^{-3} [degree], or [pulse] with the setting of [Pr. PT01].</p> <p>Setting range: 0 to 65535</p>	1000 Refer to Function column for unit.	<input type="radio"/>	<input type="radio"/>	<input type="radio"/>
PT10 ZTM Stopper type home position return stopper time		<p>Set time from a moving part touches the stopper and torques reaches to the torque limit of [Pr. PT10 Stopper type home position return - Torque limit value] to a home position set for the stopper type home position return.</p> <p>Setting range: 0 to 1000</p>	100 [ms]	<input type="radio"/>	<input type="radio"/>	<input type="radio"/>
PT11 ZTT Stopper type home position return torque limit value		<p>Set a torque limit value with [%] to the maximum torque at stopper type home position return.</p> <p>Setting range: 0.0 to 100.0</p>	15.0 [%]	<input type="radio"/>	<input type="radio"/>	<input type="radio"/>
PT12 CRP Rough match output range		<p>Set a range of the command remaining distance which outputs CPO (Rough match). The unit will be as follows depending on the positioning mode.</p> <ul style="list-style-type: none"> Point table method or program method The unit will be changed to 10^{STM} [μm], $10^{(\text{STM}-4)}$ [inch], 10^{-3} [degree], or [pulse] with the setting of [Pr. PT01]. Indexer method It will be command unit [pulse]. (unit of a load-side rotation expressed by the number of encoder resolution pulses) Refer to the Function column of [Pr. PA10] for the command unit [pulse]. <p>Setting range: 0 to 65535</p>	0 Refer to Function column for unit.	<input type="radio"/>	<input type="radio"/>	<input type="radio"/>
PT13 JOG Jog speed		<p>Set a JOG speed.</p> <p>Setting range: 0 to permissible instantaneous speed</p>	100 [r/min]/ [mm/s]	<input type="radio"/>	<input type="radio"/>	<input type="radio"/>

7. PARAMETERS

No./ symbol/name	Setting digit	Function	Initial value [unit]	Control mode		
				CP/BCD	CL	PS
PT14 *BKC Backlash compensation		<p>Set a backlash compensation for reversing command direction. This parameter compensates backlash pulses against the home position return direction. For the home position ignorance (servo-on position as home position), this turns on SON (Servo-on) and decides a home position, and compensates backlash pulses against the first rotation direction.</p> <p>Setting range: 0 to 65535</p>	0 [pulse]	<input type="radio"/>	<input type="radio"/>	<input type="radio"/>
PT15 LMPL Software limit + (third least significant digit)		<p>Set an address increasing side of the software stroke limit. Upper and lower are a set.</p> <p>Setting address:</p> <div style="text-align: center;"> </div> <p>The stop method depends on "Stop method selection at software limit detection" of [Pr. PD30]. The initial value is "Quick stop (home position erased)". Setting a same value with "Software limit -" will disable the software stroke limit. (Refer to section 7.4.) Set a same sign for [Pr. PT15] and [Pr. PT16]. A different sign will be recognized as minus sign data. When changing the direction to address decreasing, change it from the - side of the software limit ([Pr. PT17] and [Pr. PT18]). An incorrect order of the setting will trigger [AL. 37]. Therefore, cycling power may be required after [Pr. PT15] to [Pr. PT18] are all set. The unit will be changed to 10^{STM} [μm], 10^(STM-4) [inch], 10⁻³ [degree], or [pulse] with the setting of [Pr. PT01].</p> <p>Setting range: -999999 to 999999</p>	0 Refer to Function column for unit.	<input type="radio"/>	<input type="radio"/>	
PT16 LMPH Software limit + (third most significant digit)						
PT17 LMNL Software limit - (third least significant digit)		<p>Set an address decreasing side of the software stroke limit. Upper and lower are a set.</p> <p>Setting address:</p> <div style="text-align: center;"> </div> <p>The stop method depends on "Stop method selection at software limit detection" of [Pr. PD30]. The initial value is "Quick stop (home position erased)". Setting a same value with "Software limit +" will disable the software stroke limit. (Refer to section 7.4.) Set a same sign for [Pr. PT17] and [Pr. PT18]. A different sign will be recognized as minus sign data. When changing the direction to the address increasing direction, change it from the + side of the software limit ([Pr. PT15] and [Pr. PT16]). An incorrect order of the setting will trigger [AL. 37]. Therefore, cycling power may be required after [Pr. PT15] to [Pr. PT18] are all set. The unit will be changed to 10^{STM} [μm], 10^(STM-4) [inch], 10⁻³ [degree], or [pulse] with the setting of [Pr. PT01].</p> <p>Setting range: -999999 to 999999</p>	0 Refer to Function column for unit.	<input type="radio"/>	<input type="radio"/>	
PT18 LMNH Software limit - (third most significant digit)						

7. PARAMETERS

No./ symbol/name	Setting digit	Function	Initial value [unit]	Control mode		
				CP/BCD	CL	PS
PT19 *LPPL Position range output address + (third least significant digit)		<p>Set an address increasing side of the position range output address. Upper and lower are a set. Set a range which POT (Position range) turns on with [Pr. PT19] to [Pr. PT22].</p> <p>Setting address: </p> <p>The unit will be changed to 10^{STM} [μm], 10^(STM-4) [inch], 10⁻³ [degree], or [pulse] with the setting of [Pr. PT01]. Set a same sign for [Pr. PT19] and [Pr. PT20]. Setting a different sign will trigger [AL. 37 Parameter error]. When changing a setting, always set the third least significant digit before setting the third most significant digit. When changing the direction to address decreasing, change it from the - side of the position range output address ([Pr. PT21] and [Pr. PT22]). An incorrect order of the setting will trigger [AL. 37]. Therefore, cycling power may be required after [Pr. PT19] to [Pr. PT22] are all set.</p> <p>Setting range: -999999 to 999999</p>	0 Refer to Function column for unit.	○	○	
PT20 *LPPH Position range output address + (third most significant digit)						
PT21 *LNPL Position range output address - (third least significant digit)		<p>Set an address decreasing side of the position range output address. Upper and lower are a set. Set a range which POT (Position range) turns on with [Pr. PT19] to [Pr. PT22].</p> <p>Setting address: </p> <p>The unit will be changed to 10^{STM} [μm], 10^(STM-4) [inch], 10⁻³ [degree], or [pulse] with the setting of [Pr. PT01]. Set a same sign for [Pr. PT21] and [Pr. PT22]. Setting a different sign will trigger [AL. 37 Parameter error]. When changing a setting, always set the third least significant digit before setting the third most significant digit. When changing the direction to address increasing, change it from the + side of the position range output address ([Pr. PT19] and [Pr. PT20]). An incorrect order of the setting will trigger [AL. 37]. Therefore, cycling power may be required after [Pr. PT19] to [Pr. PT22] are all set.</p> <p>Setting range: -999999 to 999999</p>	0 Refer to Function column for unit.	○	○	
PT22 *LNPH Position range output address - (third most significant digit)						
PT23 OUT1 OUT1 output setting time		<p>Set an output time for when OUT1 (Program output 1) is turned on with the OUTON command. Setting "0" will keep on-state. To turn it off, use the OUTOF command.</p> <p>Setting range: 0 to 20000</p>	0 [ms]		○	
PT24 OUT2 OUT2 output setting time		<p>Set an output time for when OUT2 (Program output 2) is turned on with the OUTON command. Setting "0" will keep on-state. To turn it off, use the OUTOF command.</p> <p>Setting range: 0 to 20000</p>	0 [ms]		○	
PT25 OUT3 OUT3 output setting time		<p>Set an output time for when OUT3 (Program output 3) is turned on with the OUTON command. Setting "0" will keep on-state. To turn it off, use the OUTOF command.</p> <p>Setting range: 0 to 20000</p>	0 [ms]		○	

7. PARAMETERS

No./ symbol/name	Setting digit	Function	Initial value [unit]	Control mode																				
				CP/BCD	CL	PS																		
PT26 *TOP2 Function selection T-2	___x	Electronic gear fraction clear selection 0: Disabled 1: Enabled Selecting "Enabled" will clear a fraction of the previous command by the electronic gear at start of the automatic operation. Setting "2" or more to this digit will be "Disabled".	0h	<input type="radio"/>	<input type="radio"/>	<input type="radio"/>																		
	__x_	Current position/command position display selection Select how to display a current position and command position.	0h	<input type="radio"/>	<input type="radio"/>	<input type="radio"/>																		
		<table border="1"> <thead> <tr> <th rowspan="2">Setting value</th> <th rowspan="2">Displayed data</th> <th rowspan="2">Operation mode</th> <th colspan="2">Status display</th> </tr> <tr> <th>Current position</th> <th>Command position</th> </tr> </thead> <tbody> <tr> <td>__0_</td> <td>Positioning display</td> <td>Auto/Manual</td> <td>Actual current position will be displayed as machine home position is 0.</td> <td>Command current position will be displayed as machine home position is 0.</td> </tr> <tr> <td rowspan="2">__1_</td> <td rowspan="2">Roll feed display</td> <td>Auto</td> <td rowspan="2">Actual current position will be displayed as automatic operation start position is 0.</td> <td>When ST1 (Forward rotation start) or ST2 (Reverse rotation start) is turned on, counting starts from 0 and a command current position to the target position will be displayed. When a stop, a point table command position for the point table method will be displayed and 0 will be continuously displayed for the program method.</td> </tr> <tr> <td>Manual</td> <td>0 will be continuously displayed.</td> </tr> </tbody> </table>	Setting value	Displayed data	Operation mode	Status display		Current position	Command position	__0_	Positioning display	Auto/Manual	Actual current position will be displayed as machine home position is 0.	Command current position will be displayed as machine home position is 0.	__1_	Roll feed display	Auto	Actual current position will be displayed as automatic operation start position is 0.	When ST1 (Forward rotation start) or ST2 (Reverse rotation start) is turned on, counting starts from 0 and a command current position to the target position will be displayed. When a stop, a point table command position for the point table method will be displayed and 0 will be continuously displayed for the program method.	Manual	0 will be continuously displayed.			
	Setting value	Displayed data				Operation mode	Status display																	
			Current position	Command position																				
__0_	Positioning display	Auto/Manual	Actual current position will be displayed as machine home position is 0.	Command current position will be displayed as machine home position is 0.																				
__1_	Roll feed display	Auto	Actual current position will be displayed as automatic operation start position is 0.	When ST1 (Forward rotation start) or ST2 (Reverse rotation start) is turned on, counting starts from 0 and a command current position to the target position will be displayed. When a stop, a point table command position for the point table method will be displayed and 0 will be continuously displayed for the program method.																				
		Manual		0 will be continuously displayed.																				
		This digit will be disabled when [degree] of "Position data unit" is set in [Pr. PT01]. Additionally, setting "2" or more will be "positioning display".																						
	_x__	For manufacturer setting	0h	<input type="radio"/>	<input type="radio"/>	<input type="radio"/>																		
	x___	Mark detection function selection 0: Current position latch function 1: Interrupt positioning function (Note) Note. The interrupt positioning function is available with servo amplifiers with software version B7 or later.	0h	<input type="radio"/>	<input type="radio"/>	<input type="radio"/>																		
PT27 *ODM Operation mode selection	___x	For manufacturer setting	0h	<input type="radio"/>	<input type="radio"/>	<input type="radio"/>																		
	__x_	Manual operation method selection 0: Station JOG operation 1: JOG operation	0h	<input type="radio"/>	<input type="radio"/>	<input type="radio"/>																		
	_x__	For manufacturer setting	0h	<input type="radio"/>	<input type="radio"/>	<input type="radio"/>																		
	x___		0h	<input type="radio"/>	<input type="radio"/>	<input type="radio"/>																		

7. PARAMETERS

No./ symbol/name	Setting digit	Function	Initial value [unit]	Control mode		
				CP/BCD	CL	PS
PT28 *STN Number of stations per rotation		Set the number of stations per rotation (number of indexer stations). Setting "2" or less will be "2". Setting range: 0 to 255	8 [Stations]			○
PT29 *TOP3 Function selection T-3	Set a polarity of DOG, SIG, PI1, PI2, and PI3.					
	___x (HEX)	___x (BIN): DOG (Proximity dog) polarity selection 0: Dog detection with off 1: Dog detection with on	0h	○	○	○
		___x (BIN): SIG (External limit/Rotation direction decision/Automatic speed selection) polarity selection 0: Normally open contact 1: Normally closed contact				○
		__x_ (BIN): For manufacturer setting				
		_x__ (BIN): For manufacturer setting				
		x___ (BIN): Mark detection input polarity Select MSD (Mark detection) input polarity. 0: Normally closed contact 1: Normally open contact This is available with servo amplifiers with software version B7 or later.		○	○	
	__x_ (HEX)	___x (BIN): PI1 (Program input 1) polarity selection 0: Positive logic 1: Negative logic	0h		○	
		__x_ (BIN): PI2 (Program input 2) polarity selection 0: Positive logic 1: Negative logic			○	
		_x__ (BIN): PI3 (Program input 3) polarity selection 0: Positive logic 1: Negative logic			○	
		x___ (BIN): For manufacturer setting				
_x__	For manufacturer setting	0h				
x___	For manufacturer setting	0h				
Convert the setting value into hexadecimal as follows.						

7. PARAMETERS

No./ symbol/name	Setting digit	Function	Initial value [unit]	Control mode		
				CP/BCD	CL	PS
PT30 MSTL Mark sensor stop travel distance (lower three digits)		<p>Set a mark sensor stop travel distance. Upper and lower are a set.</p> <p>When MSD (Mark detection) is on, the remaining distance will be changed to the travel distance that is set with this parameter.</p> <p>Setting address:</p> <div style="text-align: center;"> </div> <p>When changing the setting, be sure to set the lower three digits first. Then, set the upper three digits. An incorrect order of the setting will trigger [AL. 37]. Therefore, cycling power may be required after [Pr. PT30] to [Pr. PT31] are all set. The unit will be changed to 10^{STM} [μm], 10^(STM-4) [inch], 10⁻³ [degree], or [pulse] with the setting of [Pr. PT01]. This parameter setting is available with servo amplifiers with software version B7 or later.</p> <p>Setting range: 0 to 999</p>	0 Refer to Function column for unit.	○	○	
PT31 MSTH Mark sensor stop travel distance (upper three digits)						
PT34 *PDEF Point table/program default		<p>Use this parameter when initializing point tables, programs, and cam data. The point tables, the programs, and the cam data will be the following status by being initialized. Point table: All "0" Program: Erased Cam data: Erased</p> <p>Initialize the point tables and the programs with the following procedures: 1) Set "5001h" to this parameter. 2) Cycle the power of the servo amplifier. After the servo amplifier power is on, the initialization completes in about 20 s. "dEF" will be displayed on the display (five-digit, seven-segment LED) during the initialization. After the initialization, the setting of this parameter will be "0000h" automatically.</p> <p>Initialize the cam data with the following procedures: 1) Set "5010h" to this parameter. 2) Cycle the power of the servo amplifier. After the initialization, the setting of this parameter will be "0000h" automatically.</p> <p>Initialize the point tables, the programs and the cam data with the following procedures: 1) Set "5011h" to this parameter. 2) Cycle the power of the servo amplifier. After the servo amplifier power is on, the initialization completes in about 20 s. "dEF" will be displayed on the display (five-digit, seven-segment LED) during the initialization. After the initialization, the setting of this parameter will be "0000h" automatically.</p>	0000h	○	○	
PT35 *TOP5 Function selection T-5	___ x	For manufacturer setting	0h			
	__ x _		0h			
	_ x _ _	Simple cam function selection 0: Disabled 1: Enabled This digit is enabled when the control mode is in the point table method or the program method. Enabling this digit in other control modes will trigger [AL. 37 Parameter error].	0h	○	○	
	x _ _ _	For manufacturer setting	0h			

7. PARAMETERS

No./ symbol/name	Setting digit	Function	Initial value [unit]	Control mode		
				CP/BCD	CL	PS
PT38 *TOP7 Function selection T-7	___x	For manufacturer setting	0h			
	__x_	Digital override selection 0: Override function is disabled with DI input 1: Override function is enabled with DI input	0h			○
	_x__	For manufacturer setting	0h			
	x___	Backlash compensation direction selection at data set type home position return 0: Executes backlash compensation assuming a command to the CW rotation direction before home position return. 1: Executes backlash compensation assuming a command to the CCW rotation direction before home position return. When setting this digit, execute a home position return again.	0h			○
PT39 INT Torque limit delay time		Set delay time from outputting INP (In-position) to enabling [Pr. PC35 Internal torque limit 2/internal thrust limit 2]. Setting range: 0 to 1000	100 [ms]			○
PT40 *SZS Station home position shift distance		Set a shift distance of the station home position with encoder pulse unit at home position return. Setting this parameter enables to shift the station home position (station No. 0) to the position for home position return. The following shows cautions for the setting. <ul style="list-style-type: none"> The setting of the station home position shift distance is disabled at home position return. Cycling the power will enable the setting. When a home position shift distance is longer than the in-position range, INP (In-position) will not be on regardless of cycle of the power after home position return. Setting range: -32000 to 32000	0 [pulse]			○
PT41 ORP Home position return inhibit function selection	___x	Home position return inhibit selection 0: Disabled (home position return allowed) 1: Enabled (home position return inhibited) Selecting "1" for this digit will disable the home position return regardless of turning on ST1 in the home position return mode.	0h	○	○	○
	___x_	For manufacturer setting	0h			
	_x__		0h			
	x___		0h			

7. PARAMETERS

No./ symbol/name	Setting digit	Function	Initial value [unit]	Control mode																																																																																											
				CP/BCD	CL	PS																																																																																									
PT42 *OVM Digital override minimum multiplication		<p>Set a minimum speed for when the digital override function is enabled. When you use the digital override function, multiplication can be set with [Pr. PT42] and [Pr. PT43]. Set this and [Pr. PT43] at a time. Refer to the following table for how to calculate multiplication value. Setting "0" will be recognized as "1".</p> <p>Setting range: 0 to 100</p> <table border="1" style="margin: 10px auto;"> <thead> <tr> <th colspan="4">(Note) Input device</th> <th rowspan="2">Multiplication [%]</th> </tr> <tr> <th>OV3</th> <th>OV2</th> <th>OV1</th> <th>OV0</th> </tr> </thead> <tbody> <tr><td>0</td><td>0</td><td>0</td><td>0</td><td>Fixed to 100</td></tr> <tr><td>0</td><td>0</td><td>0</td><td>1</td><td>[Pr. PT42]</td></tr> <tr><td>0</td><td>0</td><td>1</td><td>0</td><td>[Pr. PT42] + [Pr. PT43] × 1</td></tr> <tr><td>0</td><td>0</td><td>1</td><td>1</td><td>[Pr. PT42] + [Pr. PT43] × 2</td></tr> <tr><td>0</td><td>1</td><td>0</td><td>0</td><td>[Pr. PT42] + [Pr. PT43] × 3</td></tr> <tr><td>0</td><td>1</td><td>0</td><td>1</td><td>[Pr. PT42] + [Pr. PT43] × 4</td></tr> <tr><td>0</td><td>1</td><td>1</td><td>0</td><td>[Pr. PT42] + [Pr. PT43] × 5</td></tr> <tr><td>0</td><td>1</td><td>1</td><td>1</td><td>[Pr. PT42] + [Pr. PT43] × 6</td></tr> <tr><td>1</td><td>0</td><td>0</td><td>0</td><td>[Pr. PT42] + [Pr. PT43] × 7</td></tr> <tr><td>1</td><td>0</td><td>0</td><td>1</td><td>[Pr. PT42] + [Pr. PT43] × 8</td></tr> <tr><td>1</td><td>0</td><td>1</td><td>0</td><td>[Pr. PT42] + [Pr. PT43] × 9</td></tr> <tr><td>1</td><td>0</td><td>1</td><td>1</td><td>[Pr. PT42] + [Pr. PT43] × 10</td></tr> <tr><td>1</td><td>1</td><td>0</td><td>0</td><td>[Pr. PT42] + [Pr. PT43] × 11</td></tr> <tr><td>1</td><td>1</td><td>0</td><td>1</td><td>[Pr. PT42] + [Pr. PT43] × 12</td></tr> <tr><td>1</td><td>1</td><td>1</td><td>0</td><td>[Pr. PT42] + [Pr. PT43] × 13</td></tr> <tr><td>1</td><td>1</td><td>1</td><td>1</td><td>Fixed to 0</td></tr> </tbody> </table> <p>Note. 0: Off 1: On</p>	(Note) Input device				Multiplication [%]	OV3	OV2	OV1	OV0	0	0	0	0	Fixed to 100	0	0	0	1	[Pr. PT42]	0	0	1	0	[Pr. PT42] + [Pr. PT43] × 1	0	0	1	1	[Pr. PT42] + [Pr. PT43] × 2	0	1	0	0	[Pr. PT42] + [Pr. PT43] × 3	0	1	0	1	[Pr. PT42] + [Pr. PT43] × 4	0	1	1	0	[Pr. PT42] + [Pr. PT43] × 5	0	1	1	1	[Pr. PT42] + [Pr. PT43] × 6	1	0	0	0	[Pr. PT42] + [Pr. PT43] × 7	1	0	0	1	[Pr. PT42] + [Pr. PT43] × 8	1	0	1	0	[Pr. PT42] + [Pr. PT43] × 9	1	0	1	1	[Pr. PT42] + [Pr. PT43] × 10	1	1	0	0	[Pr. PT42] + [Pr. PT43] × 11	1	1	0	1	[Pr. PT42] + [Pr. PT43] × 12	1	1	1	0	[Pr. PT42] + [Pr. PT43] × 13	1	1	1	1	Fixed to 0	0 [%]			○
(Note) Input device				Multiplication [%]																																																																																											
OV3	OV2	OV1	OV0																																																																																												
0	0	0	0	Fixed to 100																																																																																											
0	0	0	1	[Pr. PT42]																																																																																											
0	0	1	0	[Pr. PT42] + [Pr. PT43] × 1																																																																																											
0	0	1	1	[Pr. PT42] + [Pr. PT43] × 2																																																																																											
0	1	0	0	[Pr. PT42] + [Pr. PT43] × 3																																																																																											
0	1	0	1	[Pr. PT42] + [Pr. PT43] × 4																																																																																											
0	1	1	0	[Pr. PT42] + [Pr. PT43] × 5																																																																																											
0	1	1	1	[Pr. PT42] + [Pr. PT43] × 6																																																																																											
1	0	0	0	[Pr. PT42] + [Pr. PT43] × 7																																																																																											
1	0	0	1	[Pr. PT42] + [Pr. PT43] × 8																																																																																											
1	0	1	0	[Pr. PT42] + [Pr. PT43] × 9																																																																																											
1	0	1	1	[Pr. PT42] + [Pr. PT43] × 10																																																																																											
1	1	0	0	[Pr. PT42] + [Pr. PT43] × 11																																																																																											
1	1	0	1	[Pr. PT42] + [Pr. PT43] × 12																																																																																											
1	1	1	0	[Pr. PT42] + [Pr. PT43] × 13																																																																																											
1	1	1	1	Fixed to 0																																																																																											
PT43 *OVS Digital override pitch width		<p>Set an override pitch width for when the digital override function is enabled. When you use the digital override function, multiplication can be set with [Pr. PT42] and [Pr. PT43]. Set this and [Pr. PT42] at a time. Refer to the table of [Pr. PT42] for settings. Setting "0" will be recognized as "1".</p> <p>Setting range: 0 to 20</p>	0 [%]			○																																																																																									

7. PARAMETERS

7.3 How to set the electronic gear

7.3.1 Electronic gear settings in the point table method and program method

(1) Setting [mm], [inch], or [pulse] with "Position data unit" of [Pr. PT01].

Adjust [Pr. PA06] and [Pr. PA07] so that the servo motor setting matches with the travel distance of the machine.

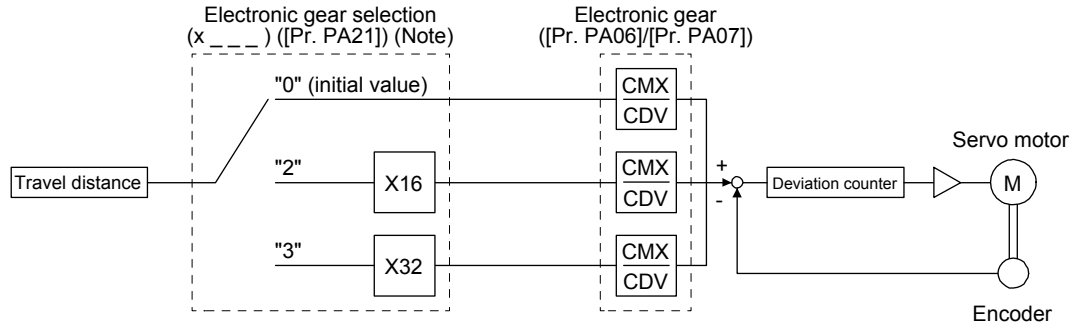

Note. For MR-J4-03A6-RJ servo amplifiers, "2 ___" or "3 ___" cannot be set to [Pr. PA21].

P_t : Servo motor encoder resolution: 4194304 [pulse/rev]

ΔS : Travel distance per servo motor revolution [mm/rev]/[inch/rev]/[pulse/rev]

$$CMX/CDV = P_t/\Delta S$$

Set the electronic gear within the following range. Setting out of the range will trigger [AL. 37 Parameter error].

Pr. PA21	Electronic gear setting range
0 ___	$1/865 < CMX/CDV < 271471$
2 ___	$1/13825 < CMX/CDV < 16967$
3 ___	$1/27649 < CMX/CDV < 8484$

The following setting example explains how to calculate the electronic gear.

POINT

- To calculate the electronic gear, the following specification symbols are required.
 - Pb: Ball screw lead [mm]
 - 1/n: Reduction ratio
 - Pt: Servo motor encoder resolution [pulse/rev]
 - ΔS : Travel distance per servo motor revolution [mm/rev]

(a) Setting example of a ball screw

Machine specifications

Ball screw lead Pb = 10 [mm]

Reduction ratio: $1/n = Z_1/Z_2 = 1/2$

Z_1 : Number of gear teeth on servo motor side

Z_2 : Number of gear teeth on load gear

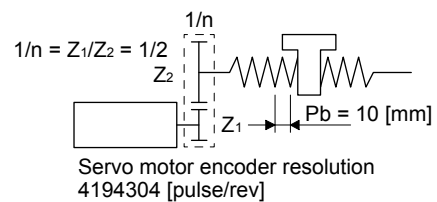

7. PARAMETERS

Servo motor encoder resolution $P_t = 4194304$ [pulse/rev]

$$\frac{CMX}{CDV} = \frac{P_t}{\Delta S} = \frac{P_t}{n \cdot P_b \cdot \alpha \text{ (Note)}} = \frac{4194304}{1/2 \cdot 10 \cdot 1000} = \frac{4194304}{5000} = \frac{524288}{625}$$

Note. Because the command unit is "mm", $\alpha = 1000$ is set. When the unit is "inch", convert the setting into $\alpha = 10000$. When the unit is "pulse", convert the setting into $\alpha = 1$.

Therefore, set $CMX = 524288$ and $CDV = 625$.

(b) Setting example of a conveyor

Machine specifications

Pulley diameter: $r = 160$ [mm]

Reduction ratio: $1/n = Z_1/Z_2 = 1/3$

Z_1 : Number of gear teeth on servo motor side

Z_2 : Number of gear teeth on load gear

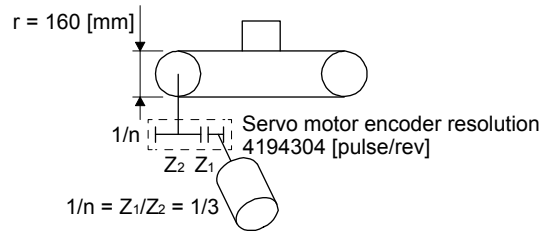

Servo motor encoder resolution $P_t = 4194304$ [pulse/rev]

$$\frac{CMX}{CDV} = \frac{P_t}{\Delta S} = \frac{P_t}{n \cdot r \cdot \pi \cdot \alpha \text{ (Note)}} = \frac{4194304}{1/3 \cdot 160 \cdot \pi \cdot 1000} = \frac{4194304}{167551.61} \approx \frac{524288}{20944}$$

Note. Because the command unit is "mm", $\alpha = 1000$ is set. When the unit is "inch", convert the setting into $\alpha = 10000$. When the unit is "pulse", convert the setting into $\alpha = 1$.

Reduce CMX and CDV to within the setting range or lower and round off each value to the closest whole number.

Therefore, set $CMX = 524288$ and $CDV = 20944$.

(2) Setting [degree] with "Position data unit" of [Pr. PT01].

Set the number of gear teeth on machine side to [Pr. PA06] and number of gear teeth on servo motor side to [Pr. PA07].

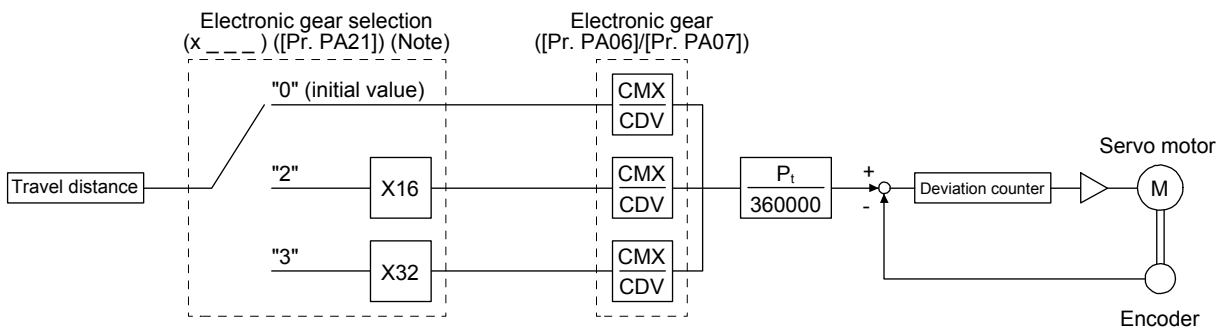

Note. For MR-J4-03A6-RJ servo amplifiers, "2 ___" or "3 ___" cannot be set to [Pr. PA21].

P_t : Servo motor encoder resolution: 4194304 [pulse/rev]

7. PARAMETERS

Set the electronic gear within the following range. Setting out of the range will trigger [AL. 37 Parameter error].

- (a) Set values to make numerator and denominator 16384 or lower if the electronic gear (CMX/CDV) is reduced to its lowest terms.
- (b) Set values to make numerator and denominator 16777216 or lower if $(CMX \times Pt)/(CDV \times 360000)$ is reduced to its lowest terms.

The following shows a setting example of the electronic gear.

Number of gear teeth on machine side: 25, number of gear teeth on servo motor side: 11

Set [Pr. PA06] = 25 and [Pr. PA07] = 11.

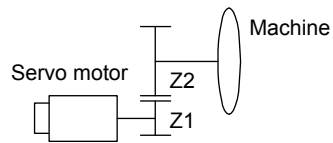

P_t (Servo motor resolution): 4194304 pulses/rev

Z1: Number of gear teeth on servo motor side

Z2: Number of gear teeth on machine side

Z1: Z2 = 11:25

7. PARAMETERS

7.3.2 Electronic gear setting in the indexer method

Adjust [Pr. PA06] and [Pr. PA07] to align the rotation amount "m" of the servo motor shaft necessary to rotate the load side for "n" times. The following shows a setting example of the electronic gear.

- (1) Number of pulley teeth on machine side: 50, number of pulley teeth on servo motor side: 20
Set [Pr. PA06] = 50 and [Pr. PA07] = 20.

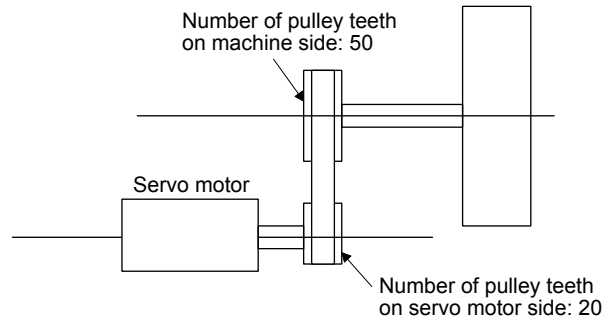

- (2) Number of pulley teeth on machine side: 50, number of pulley teeth on servo motor side: 20, with geared servo motor of 1/9
Set [Pr. PA06] = 450 and [Pr. PA07] = 20.

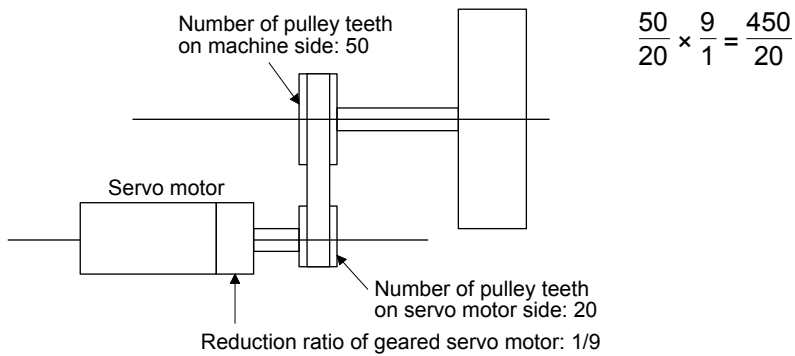

7. PARAMETERS

7.4 Software limit

The limit stop with the software limit ([Pr. PT15] to [Pr. PT18]) is the same as the motion of the stroke end. Exceeding a setting range will stop and servo-lock the shaft. This will be enabled at power-on and will be disabled at home position return. Setting a same value to "Software limit +" and "Software limit -" will disable this function. Setting a larger value to "Software limit -" than "Software limit +" will trigger [AL. 37.2 Parameter combination error].

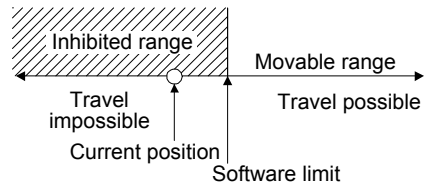

The software limit is disabled in the indexer method.

7. PARAMETERS

7.5 Stop method for LSP (Forward rotation stroke end) off or LSN (Reverse rotation stroke end) off

Select a servo motor stop method for when LSP (Forward rotation stroke end) or LSN (Reverse rotation stroke end) is off with the first digit of [Pr. PD30].

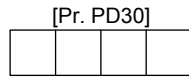

- Stop method selection for LSP (Forward rotation stroke end) off or LSN (Reverse rotation stroke end) off
- 0: Quick stop (home position erased)
 - 1: Slow stop (home position erased)
 - 2: Slow stop (deceleration to a stop by deceleration time constant)
 - 3: Quick stop (stop by clearing remaining distance)

[Pr. PD30] setting	Operation status		Remark
	During rotation at constant speed	During deceleration to a stop	
___ 0 (initial value)	— No S-pattern acceleration/ deceleration - - - With S-pattern acceleration/ deceleration Servo motor speed (linear servo motor speed) 0 r/min (0 mm/s) LSP or LSN: ON OFF	— No S-pattern acceleration/ deceleration - - - With S-pattern acceleration/ deceleration Servo motor speed (linear servo motor speed) 0 r/min (0 mm/s) LSP or LSN: ON OFF	Erases the droop pulses and stops the motor. Erases the home position. A difference will be generated between command position and current position. Perform a home position return again.
___ 1	— No S-pattern acceleration/ deceleration - - - With S-pattern acceleration/ deceleration Servo motor speed (linear servo motor speed) 0 r/min (0 mm/s) Part of droop pulses LSP or LSN: ON OFF	— No S-pattern acceleration/ deceleration - - - With S-pattern acceleration/ deceleration Servo motor speed (linear servo motor speed) 0 r/min (0 mm/s) Part of droop pulses LSP or LSN: ON OFF	Erases the droop pulse portion and stops the motor. Erases the home position. A difference will be generated between command position and current position. Perform a home position return again.
___ 2 (Note 1)	— No S-pattern acceleration/ deceleration - - - With S-pattern acceleration/ deceleration Servo motor speed (linear servo motor speed) 0 r/min (0 mm/s) Acceleration/ deceleration time constant + S-pattern acceleration/ deceleration time constant Acceleration/ deceleration time constant Decelerates to stop. LSP or LSN: ON OFF	— No S-pattern acceleration/ deceleration - - - With S-pattern acceleration/ deceleration Servo motor speed (linear servo motor speed) 0 r/min (0 mm/s) Continues deceleration to stop. LSP or LSN: ON OFF	Decelerates to a stop with the deceleration time constant currently selected with the point table or the program. Continues operation for a delay portion of the S-pattern acceleration/ deceleration time constants. Maintains the home position.
___ 3 (Note 2)	— No S-pattern acceleration/ deceleration - - - With S-pattern acceleration/ deceleration Servo motor speed (linear servo motor speed) 0 r/min (0 mm/s) Part of S-pattern acceleration/ deceleration time constants + Part of droop pulses Part of droop pulses LSP or LSN: ON OFF	— No S-pattern acceleration/ deceleration - - - With S-pattern acceleration/ deceleration Servo motor speed (linear servo motor speed) 0 r/min (0 mm/s) Part of S-pattern acceleration/ deceleration time constants + Part of droop pulses Part of droop pulses LSP or LSN: ON OFF	Erases the droop pulse portion and stops the motor. Continues operation for a delay portion of the S-pattern acceleration/ deceleration time constants. Maintains the home position.

- Note 1. This will be the same motion as setting "___ 1" to [Pr. PD30] in the indexer method.
 Note 2. This will be the same motion as setting "___ 0" to [Pr. PD30] in the indexer method.

7. PARAMETERS

7.6 Stop method at software limit detection

Select a stop method of the servo motor for when a software limit ([Pr. PT15] to [Pr. PT18]) is detected with the setting of the third digit in [Pr. PD30]. The software limit limits a command position controlled in the servo amplifier. Therefore, actual stop position will not reach the set position of the software limit. The software limit is disabled in the indexer method.

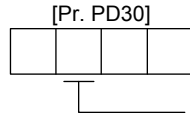

- Stop method selection at software limit detection
- 0: Quick stop (home position erased)
 - 1: Slow stop (home position erased)
 - 2: Slow stop (deceleration to a stop by deceleration time constant)
 - 3: Quick stop (stop by clearing remaining distance)

[Pr. PD30] setting	Operation status		Remark
	During rotation at constant speed	During deceleration to a stop	
_ 0 _ _ (initial value)	— No S-pattern acceleration/ deceleration - - - With S-pattern acceleration/ deceleration Servo motor speed (linear servo motor speed) 0 r/min (0 mm/s) 	— No S-pattern acceleration/ deceleration - - - With S-pattern acceleration/ deceleration Servo motor speed (linear servo motor speed) 0 r/min (0 mm/s) 	Erases the droop pulses and stops the motor. Erases the home position. A difference will be generated between command position and current position. Perform a home position return again.
_ 1 _ _	— No S-pattern acceleration/ deceleration - - - With S-pattern acceleration/ deceleration Servo motor speed (linear servo motor speed) 0 r/min (0 mm/s) 	— No S-pattern acceleration/ deceleration - - - With S-pattern acceleration/ deceleration Servo motor speed (linear servo motor speed) 0 r/min (0 mm/s) 	Erases the droop pulse portion and stops the motor. Erases the home position. A difference will be generated between command position and current position. Perform a home position return again.
_ 2 _ _	— No S-pattern acceleration/ deceleration - - - With S-pattern acceleration/ deceleration Servo motor speed (linear servo motor speed) 0 r/min (0 mm/s) 	— No S-pattern acceleration/ deceleration - - - With S-pattern acceleration/ deceleration Servo motor speed (linear servo motor speed) 0 r/min (0 mm/s) 	Decelerates to a stop with the deceleration time constant currently selected with the point table or the program. Continues operation for a delay portion of the S-pattern acceleration/deceleration time constants. Keeps the home position.
_ 3 _ _	— No S-pattern acceleration/ deceleration - - - With S-pattern acceleration/ deceleration Servo motor speed (linear servo motor speed) 0 r/min (0 mm/s) 	— No S-pattern acceleration/ deceleration - - - With S-pattern acceleration/ deceleration Servo motor speed (linear servo motor speed) 0 r/min (0 mm/s) 	Erases the droop pulse portion and stops the motor. Continues operation for a delay portion of the S-pattern acceleration/deceleration time constants. Keeps the home position.

8. TROUBLESHOOTING

8. TROUBLESHOOTING

POINT
<ul style="list-style-type: none"> ● Refer to "MELSERVO-J4 Servo Amplifier Instruction Manual (Troubleshooting)" for details of alarms and warnings. ● As soon as an alarm occurs, turn SON (Servo-on) off and interrupt the power. ● [AL. 37 Parameter error] and warnings (except [AL. F0 Tough drive warning]) are not recorded in the alarm history.

When an error occurs during operation, the corresponding alarm and warning are displayed. When an alarm or warning is displayed, refer to "MELSERVO-J4 Servo Amplifier Instruction Manual (Troubleshooting)" to remove the failure. When an alarm occurs, ALM will turn off.

8.1 Explanation for the lists

(1) No./Name/Detail No./Detail name

Indicates each No./Name/Detail No./Detail name of alarms or warnings.

(2) Stop method

For the alarms and warnings in which "SD" is written in the stop method column, the servo motor stops with the dynamic brake after forced stop deceleration. For the alarms and warnings in which "DB" or "EDB" is written in the stop method column, the servo motor stops with the dynamic brake without forced stop deceleration.

(3) Alarm deactivation

After its cause has been removed, the alarm can be deactivated in any of the methods marked ○ in the alarm deactivation column. Warnings are automatically canceled after the cause of occurrence is removed. Alarms are deactivated with alarm reset or cycling the power.

Alarm deactivation	Explanation
Alarm reset	1. Turning on RES (Reset) with input device 2. Pushing the "SET" button while the display of the servo amplifier is the current alarm display status 3. Pushing "Occurring Alarm Reset" in the "Alarm Display" window of MR Configurator2
Cycling the power	Turning off the power and on again

(4) Alarm code

To output alarm codes, set [Pr. PD34] to "___1". Alarm codes are outputted by on/off of bit 0 to bit 2. Warnings ([AL. 91] to [AL. F3]) do not have alarm codes. The alarm codes in the following table will be outputted when they occur. The alarm codes will not be outputted in normal condition.

When using an MR-D01 extension IO unit, you can output alarm codes by setting [Pr. Po12] to "___1". Alarm codes are outputted by on/off of bit 0 to bit 3.

8. TROUBLESHOOTING

8.2 Alarm list

	No.	Name	Detail No.	Detail name	Stop Type (Note 2, 3)	Alarm deactivation		Alarm code		
						Alarm reset	Cycling the power	CN1-22 (Bit 2)	CN1-23 (Bit 1)	CN1-24 (Bit 0)
Alarm	10	Undervoltage	10.1	Voltage drop in the control circuit power	EDB	○	○	0	1	0
			10.2	Voltage drop in the main circuit power	SD	○	○			
	11	Switch setting error	11.1	Axis number setting error/station number setting error	DB	▤	○	▤	▤	▤
			11.2	Disabling control axis setting error	DB	▤	○	▤	▤	▤
	12	Memory error 1 (RAM)	12.1	RAM error 1	DB	▤	○	0	0	0
			12.2	RAM error 2	DB	▤	○			
			12.3	RAM error 3	DB	▤	○			
			12.4	RAM error 4	DB	▤	○			
			12.5	RAM error 5	DB	▤	○			
			12.6	RAM error 6	DB	▤	○			
	13	Clock error	13.1	Clock error 1	DB	▤	○	0	0	0
			13.2	Clock error 2	DB	▤	○			
	14	Control process error	14.1	Control process error 1	DB	▤	○	0	0	0
			14.2	Control process error 2	DB	▤	○			
			14.3	Control process error 3	DB	▤	○			
			14.4	Control process error 4	DB	▤	○			
			14.5	Control process error 5	DB	▤	○			
			14.6	Control process error 6	DB	▤	○			
			14.7	Control process error 7	DB	▤	○			
			14.8	Control process error 8	DB	▤	○			
			14.9	Control process error 9	DB	▤	○			
			14.A	Control process error 10	DB	▤	○			
			14.B	Control process error 11	DB	▤	○			
	15	Memory error 2 (EEP-ROM)	15.1	EEP-ROM error at power on	DB	▤	○	0	0	0
			15.2	EEP-ROM error during operation	DB	▤	○			
			15.4	Home position information read error	DB	▤	○			
	16	Encoder initial communication error 1	16.1	Encoder initial communication - Receive data error 1	DB	▤	○	1	1	0
			16.2	Encoder initial communication - Receive data error 2	DB	▤	○			
			16.3	Encoder initial communication - Receive data error 3	DB	▤	○			
			16.5	Encoder initial communication - Transmission data error 1	DB	▤	○			
			16.6	Encoder initial communication - Transmission data error 2	DB	▤	○			
			16.7	Encoder initial communication - Transmission data error 3	DB	▤	○			
16.A			Encoder initial communication - Process error 1	DB	▤	○				
16.B			Encoder initial communication - Process error 2	DB	▤	○				
16.C			Encoder initial communication - Process error 3	DB	▤	○				
16.D			Encoder initial communication - Process error 4	DB	▤	○				
16.E			Encoder initial communication - Process error 5	DB	▤	○				
16.F			Encoder initial communication - Process error 6	DB	▤	○				

8. TROUBLESHOOTING

	No.	Name	Detail No.	Detail name	Stop Type (Note 2, 3)	Alarm deactivation		Alarm code		
						Alarm reset	Cycling the power	CN1-22 (Bit 2)	CN1-23 (Bit 1)	CN1-24 (Bit 0)
Alarm	17	Board error	17.1	Board error 1	DB	<input checked="" type="checkbox"/>	<input type="checkbox"/>	0	0	0
			17.3	Board error 2	DB	<input checked="" type="checkbox"/>	<input type="checkbox"/>			
			17.4	Board error 3	DB	<input checked="" type="checkbox"/>	<input type="checkbox"/>			
			17.5	Board error 4	DB	<input checked="" type="checkbox"/>	<input type="checkbox"/>			
			17.6	Board error 5	DB	<input checked="" type="checkbox"/>	<input type="checkbox"/>			
			17.7	Board error 7	DB	<input checked="" type="checkbox"/>	<input type="checkbox"/>			
			17.8	Board error 6	EDB	<input checked="" type="checkbox"/>	<input type="checkbox"/>			
			17.9	Board error 8	DB	<input checked="" type="checkbox"/>	<input type="checkbox"/>			
	19	Memory error 3 (Flash-ROM)	19.1	Flash-ROM error 1	DB	<input checked="" type="checkbox"/>	<input type="checkbox"/>	0	0	0
			19.2	Flash-ROM error 2	DB	<input checked="" type="checkbox"/>	<input type="checkbox"/>			
			19.3	Flash-ROM error 3	DB	<input checked="" type="checkbox"/>	<input type="checkbox"/>			
	1A	Servo motor combination error	1A.1	Servo motor combination error 1	DB	<input checked="" type="checkbox"/>	<input type="checkbox"/>	1	1	0
			1A.2	Servo motor control mode combination error	DB	<input checked="" type="checkbox"/>	<input type="checkbox"/>			
			1A.4	Servo motor combination error 2	DB	<input checked="" type="checkbox"/>	<input type="checkbox"/>			
	1B	Converter alarm	1B.1	Converter unit error	DB	<input checked="" type="checkbox"/>	<input type="checkbox"/>	0	1	0
	1E	Encoder initial communication error 2	1E.1	Encoder malfunction	DB	<input checked="" type="checkbox"/>	<input type="checkbox"/>	1	1	0
			1E.2	Load-side encoder malfunction	DB	<input checked="" type="checkbox"/>	<input type="checkbox"/>			
	1F	Encoder initial communication error 3	1F.1	Incompatible encoder	DB	<input checked="" type="checkbox"/>	<input type="checkbox"/>	1	1	0
			1F.2	Incompatible load-side encoder	DB	<input checked="" type="checkbox"/>	<input type="checkbox"/>			
	20	Encoder normal communication error 1	20.1	Encoder normal communication - Receive data error 1	EDB	<input checked="" type="checkbox"/>	<input type="checkbox"/>	1	1	0
			20.2	Encoder normal communication - Receive data error 2	EDB	<input checked="" type="checkbox"/>	<input type="checkbox"/>			
			20.3	Encoder normal communication - Receive data error 3	EDB	<input checked="" type="checkbox"/>	<input type="checkbox"/>			
			20.5	Encoder normal communication - Transmission data error 1	EDB	<input checked="" type="checkbox"/>	<input type="checkbox"/>			
			20.6	Encoder normal communication - Transmission data error 2	EDB	<input checked="" type="checkbox"/>	<input type="checkbox"/>			
			20.7	Encoder normal communication - Transmission data error 3	EDB	<input checked="" type="checkbox"/>	<input type="checkbox"/>			
			20.9	Encoder normal communication - Receive data error 4	EDB	<input checked="" type="checkbox"/>	<input type="checkbox"/>			
			20.A	Encoder normal communication - Receive data error 5	EDB	<input checked="" type="checkbox"/>	<input type="checkbox"/>			
21	Encoder normal communication error 2	21.1	Encoder data error 1	EDB	<input checked="" type="checkbox"/>	<input type="checkbox"/>	1	1	0	
		21.2	Encoder data update error	EDB	<input checked="" type="checkbox"/>	<input type="checkbox"/>				
		21.3	Encoder data waveform error	EDB	<input checked="" type="checkbox"/>	<input type="checkbox"/>				
		21.4	Encoder non-signal error	EDB	<input checked="" type="checkbox"/>	<input type="checkbox"/>				
		21.5	Encoder hardware error 1	EDB	<input checked="" type="checkbox"/>	<input type="checkbox"/>				
		21.6	Encoder hardware error 2	EDB	<input checked="" type="checkbox"/>	<input type="checkbox"/>				
		21.9	Encoder data error 2	EDB	<input checked="" type="checkbox"/>	<input type="checkbox"/>				
24	Main circuit error	24.1	Ground fault detected at hardware detection circuit	DB	<input checked="" type="checkbox"/>	<input type="checkbox"/>	1	0	0	
		24.2	Ground fault detected by software detection function	DB	<input type="checkbox"/>	<input type="checkbox"/>				
25	Absolute position erased	25.1	Servo motor encoder - Absolute position erased	DB	<input checked="" type="checkbox"/>	<input type="checkbox"/>	1	1	0	
		25.2	Scale measurement encoder - Absolute position erased	DB	<input checked="" type="checkbox"/>	<input type="checkbox"/>				

8. TROUBLESHOOTING

	No.	Name	Detail No.	Detail name	Stop Type (Note 2, 3)	Alarm deactivation		Alarm code		
						Alarm reset	Cycling the power	CN1-22 (Bit 2)	CN1-23 (Bit 1)	CN1-24 (Bit 0)
Alarm	27	Initial magnetic pole detection error	27.1	Initial magnetic pole detection - Abnormal termination	DB	○	○	1	1	0
			27.2	Initial magnetic pole detection - Time out error	DB	○	○			
			27.3	Initial magnetic pole detection - Limit switch error	DB	○	○			
			27.4	Initial magnetic pole detection - Estimated error	DB	○	○			
			27.5	Initial magnetic pole detection - Position deviation error	DB	○	○			
			27.6	Initial magnetic pole detection - Speed deviation error	DB	○	○			
			27.7	Initial magnetic pole detection - Current error	DB	○	○			
	28	Linear encoder error 2	28.1	Linear encoder - Environment error	EDB	△	○	1	1	0
	2A	Linear encoder error 1	2A.1	Linear encoder error 1-1	EDB	△	○	1	1	0
			2A.2	Linear encoder error 1-2	EDB	△	○			
			2A.3	Linear encoder error 1-3	EDB	△	○			
			2A.4	Linear encoder error 1-4	EDB	△	○			
			2A.5	Linear encoder error 1-5	EDB	△	○			
			2A.6	Linear encoder error 1-6	EDB	△	○			
			2A.7	Linear encoder error 1-7	EDB	△	○			
			2A.8	Linear encoder error 1-8	EDB	△	○			
	2B	Encoder counter error	2B.1	Encoder counter error 1	EDB	△	○	1	1	0
			2B.2	Encoder counter error 2	EDB	△	○			
	30	Regenerative error	30.1	Regeneration heat error	DB	○ (Note 1)	○ (Note 1)	0	0	1
			30.2	Regeneration signal error	DB	○ (Note 1)	○ (Note 1)			
			30.3	Regeneration feedback signal error	DB	○ (Note 1)	○ (Note 1)			
	31	Overspeed	31.1	Abnormal motor speed	SD	○	○	1	0	1
	32	Overcurrent	32.1	Overcurrent detected at hardware detection circuit (during operation)	DB	△	○	1	0	0
			32.2	Overcurrent detected at software detection function (during operation)	DB	○	○			
			32.3	Overcurrent detected at hardware detection circuit (during a stop)	DB	△	○			
			32.4	Overcurrent detected at software detection function (during a stop)	DB	○	○			
	33	Overvoltage	33.1	Main circuit voltage error	EDB	○	○	0	0	1
34	SSCNET receive error 1	34.1	SSCNET receive data error	SD	○	○	△	△	△	
		34.2	SSCNET connector connection error	SD	○	○	△	△	△	
		34.3	SSCNET communication data error	SD	○	○	△	△	△	
		34.4	Hardware error signal detection	SD	○	○	△	△	△	
		34.5	SSCNET receive data error (safety observation function)	SD	○	○	△	△	△	
		34.6	SSCNET communication data error (safety observation function)	SD	○	○	△	△	△	
35	Command frequency error	35.1	Command frequency error	SD	○	○	1	0	1	
36	SSCNET receive error 2	36.1	Continuous communication data error	SD	○	○	△	△	△	
		36.2	Continuous communication data error (safety observation function)	SD	○	○	△	△	△	

8. TROUBLESHOOTING

	No.	Name	Detail No.	Detail name	Stop Type (Note 2, 3)	Alarm deactivation		Alarm code		
						Alarm reset	Cycling the power	CN1-22 (Bit 2)	CN1-23 (Bit 1)	CN1-24 (Bit 0)
Alarm	37	Parameter error	37.1	Parameter setting range error	DB	<input type="checkbox"/>	<input type="checkbox"/>	0	0	0
			37.2	Parameter combination error	DB	<input type="checkbox"/>	<input type="checkbox"/>			
			37.3	Point table setting error	DB	<input type="checkbox"/>	<input type="checkbox"/>			
	39	Program error	39.1	Program error	DB	<input type="checkbox"/>	<input type="checkbox"/>	0	0	0
			39.2	Instruction argument external error	DB	<input type="checkbox"/>	<input type="checkbox"/>			
			39.3	Register No. error	DB	<input type="checkbox"/>	<input type="checkbox"/>			
			39.4	Non-correspondence instruction error	DB	<input type="checkbox"/>	<input type="checkbox"/>			
	3A	Inrush current suppression circuit error	3A.1	Inrush current suppression circuit error	EDB	<input type="checkbox"/>	<input type="checkbox"/>	0	0	0
	3D	Parameter setting error for driver communication	3D.1	Parameter combination error for driver communication on slave	DB	<input type="checkbox"/>	<input type="checkbox"/>	<input type="checkbox"/>	<input type="checkbox"/>	<input type="checkbox"/>
			3D.2	Parameter combination error for driver communication on master	DB	<input type="checkbox"/>	<input type="checkbox"/>	<input type="checkbox"/>	<input type="checkbox"/>	<input type="checkbox"/>
	3E	Operation mode error	3E.1	Operation mode error	DB	<input type="checkbox"/>	<input type="checkbox"/>	<input type="checkbox"/>	<input type="checkbox"/>	<input type="checkbox"/>
			3E.6	Operation mode switch error	DB	<input type="checkbox"/>	<input type="checkbox"/>	0	0	0
	42	Servo control error (for linear servo motor and direct drive motor)	42.1	Servo control error by position deviation	EDB	(Note 4)	<input type="checkbox"/>	1	1	0
			42.2	Servo control error by speed deviation	EDB	(Note 4)	<input type="checkbox"/>			
			42.3	Servo control error by torque/thrust deviation	EDB	(Note 4)	<input type="checkbox"/>			
		Fully closed loop control error (for fully closed loop control)	42.8	Fully closed loop control error by position deviation	EDB	(Note 4)	<input type="checkbox"/>			
			42.9	Fully closed loop control error by speed deviation	EDB	(Note 4)	<input type="checkbox"/>			
			42.A	Fully closed loop control error by position deviation during command stop	EDB	(Note 4)	<input type="checkbox"/>			
	45	Main circuit device overheat	45.1	Main circuit device overheat error 1	SD	<input type="checkbox"/> (Note 1)	<input type="checkbox"/> (Note 1)	0	1	1
			45.2	Main circuit device overheat error 2	SD	<input type="checkbox"/> (Note 1)	<input type="checkbox"/> (Note 1)			
	46	Servo motor overheat	46.1	Abnormal temperature of servo motor 1	SD	<input type="checkbox"/> (Note 1)	<input type="checkbox"/> (Note 1)	0	1	1
46.2			Abnormal temperature of servo motor 2	SD	<input type="checkbox"/> (Note 1)	<input type="checkbox"/> (Note 1)				
46.3			Thermistor disconnected error	SD	<input type="checkbox"/> (Note 1)	<input type="checkbox"/> (Note 1)				
46.4			Thermistor circuit error	SD	<input type="checkbox"/> (Note 1)	<input type="checkbox"/> (Note 1)				
46.5			Abnormal temperature of servo motor 3	DB	<input type="checkbox"/> (Note 1)	<input type="checkbox"/> (Note 1)				
46.6			Abnormal temperature of servo motor 4	DB	<input type="checkbox"/> (Note 1)	<input type="checkbox"/> (Note 1)				
47	Cooling fan error	47.1	Cooling fan stop error	SD	<input type="checkbox"/>	<input type="checkbox"/>	0	1	1	
		47.2	Cooling fan speed reduction error	SD	<input type="checkbox"/>	<input type="checkbox"/>				
50	Overload 1	50.1	Thermal overload error 1 during operation	SD	<input type="checkbox"/> (Note 1)	<input type="checkbox"/> (Note 1)	0	1	1	
		50.2	Thermal overload error 2 during operation	SD	<input type="checkbox"/> (Note 1)	<input type="checkbox"/> (Note 1)				
		50.3	Thermal overload error 4 during operation	SD	<input type="checkbox"/> (Note 1)	<input type="checkbox"/> (Note 1)				
		50.4	Thermal overload error 1 during a stop	SD	<input type="checkbox"/> (Note 1)	<input type="checkbox"/> (Note 1)				
		50.5	Thermal overload error 2 during a stop	SD	<input type="checkbox"/> (Note 1)	<input type="checkbox"/> (Note 1)				
		50.6	Thermal overload error 4 during a stop	SD	<input type="checkbox"/> (Note 1)	<input type="checkbox"/> (Note 1)				

8. TROUBLESHOOTING

	No.	Name	Detail No.	Detail name	Stop Type (Note 2, 3)	Alarm deactivation		Alarm code		
						Alarm reset	Cycling the power	CN1-22 (Bit 2)	CN1-23 (Bit 1)	CN1-24 (Bit 0)
Alarm	51	Overload 2	51.1	Thermal overload error 3 during operation	DB	○ (Note 1)	○ (Note 1)	0	1	1
			51.2	Thermal overload error 3 during a stop	DB	○ (Note 1)	○ (Note 1)			
	52	Error excessive	52.1	Excess droop pulse 1	SD	○	○	1	0	1
			52.3	Excess droop pulse 2	SD	○	○			
			52.4	Error excessive during 0 torque limit	SD	○	○			
			52.5	Excess droop pulse 3	EDB	○	○			
	54	Oscillation detection	54.1	Oscillation detection error	EDB	○	○	0	1	1
	56	Forced stop error	56.2	Over speed during forced stop	EDB	○	○	1	1	0
			56.3	Estimated distance over during forced stop	EDB	○	○			
	61	Operation error	61.1	Point table setting error	DB	○	○	1	0	1
	63	STO timing error	63.1	STO1 off	DB	○	○	1	1	0
			63.2	STO2 off	DB	○	○			
			63.5	STO by functional safety unit	DB	○	○			
	64	Functional safety unit setting error	64.1	STO input error	DB	△	○	0	0	0
			64.2	Compatibility mode setting error	DB	△	○			
			64.3	Operation mode setting error	DB	△	○			
	65	Functional safety unit connection error	65.1	Functional safety unit communication error 1	SD	△	○	0	0	0
			65.2	Functional safety unit communication error 2	SD	△	○			
			65.3	Functional safety unit communication error 3	SD	△	○			
			65.4	Functional safety unit communication error 4	SD	△	○			
65.5			Functional safety unit communication error 5	SD	△	○				
65.6			Functional safety unit communication error 6	SD	△	○				
65.7			Functional safety unit communication error 7	SD	△	○				
65.8			Functional safety unit shut-off signal error 1	DB	△	○				
65.9			Functional safety unit shut-off signal error 2	DB	△	○				
66	Encoder initial communication error (safety observation function)	66.1	Encoder initial communication - Receive data error 1 (safety observation function)	DB	△	○	1	1	0	
		66.2	Encoder initial communication - Receive data error 2 (safety observation function)	DB	△	○				
		66.3	Encoder initial communication - Receive data error 3 (safety observation function)	DB	△	○				
		66.7	Encoder initial communication - Transmission data error 1 (safety observation function)	DB	△	○				
		66.9	Encoder initial communication - Process error 1 (safety observation function)	DB	△	○				

8. TROUBLESHOOTING

	No.	Name	Detail No.	Detail name	Stop Type (Note 2, 3)	Alarm deactivation		Alarm code		
						Alarm reset	Cycling the power	CN1-22 (Bit 2)	CN1-23 (Bit 1)	CN1-24 (Bit 0)
Alarm	67	Encoder normal communication error 1 (safety observation function)	67.1	Encoder normal communication - Receive data error 1 (safety observation function)	DB	/	○	1	1	0
			67.2	Encoder normal communication - Receive data error 2 (safety observation function)	DB	/	○			
			67.3	Encoder normal communication - Receive data error 3 (safety observation function)	DB	/	○			
			67.4	Encoder normal communication - Receive data error 4 (safety observation function)	DB	/	○			
			67.7	Encoder normal communication - Transmission data error 1 (safety observation function)	DB	/	○			
	68	STO diagnosis error	68.1	Mismatched STO signal error	DB	/	○	0	0	0
	69	Command error	69.1	Forward rotation-side software limit detection - Command excess error	SD	○	○	/	/	/
			69.2	Reverse rotation-side software limit detection - Command excess error	SD	○	○	/	/	/
			69.3	Forward rotation stroke end detection - Command excess error	SD	○	○	/	/	/
			69.4	Reverse rotation stroke end detection - Command excess error	SD	○	○	/	/	/
			69.5	Upper stroke limit detection - Command excess error	SD	○	○	/	/	/
			69.6	Lower stroke limit detection - Command excess error	SD	○	○	/	/	/
	70	Load-side encoder initial communication error 1	70.1	Load-side encoder initial communication - Receive data error 1	DB	/	○	1	1	0
70.2			Load-side encoder initial communication - Receive data error 2	DB	/	○				
70.3			Load-side encoder initial communication - Receive data error 3	DB	/	○				
70.5			Load-side encoder initial communication - Transmission data error 1	DB	/	○				
70.6			Load-side encoder initial communication - Transmission data error 2	DB	/	○				
70.7			Load-side encoder initial communication - Transmission data error 3	DB	/	○				
70.A			Load-side encoder initial communication - Process error 1	DB	/	○				
70.B			Load-side encoder initial communication - Process error 2	DB	/	○				
70.C			Load-side encoder initial communication - Process error 3	DB	/	○				
70.D			Load-side encoder initial communication - Process error 4	DB	/	○				
70.E			Load-side encoder initial communication - Process error 5	DB	/	○				
70.F			Load-side encoder initial communication - Process error 6	DB	/	○				

8. TROUBLESHOOTING

	No.	Name	Detail No.	Detail name	Stop Type (Note 2, 3)	Alarm deactivation		Alarm code		
						Alarm reset	Cycling the power	CN1-22 (Bit 2)	CN1-23 (Bit 1)	CN1-24 (Bit 0)
Alarm	71	Load-side encoder normal communication error 1	71.1	Load-side encoder normal communication - Receive data error 1	EDB	<input checked="" type="checkbox"/>	<input type="checkbox"/>	1	1	0
			71.2	Load-side encoder normal communication - Receive data error 2	EDB	<input checked="" type="checkbox"/>	<input type="checkbox"/>			
			71.3	Load-side encoder normal communication - Receive data error 3	EDB	<input checked="" type="checkbox"/>	<input type="checkbox"/>			
			71.5	Load-side encoder normal communication - Transmission data error 1	EDB	<input checked="" type="checkbox"/>	<input type="checkbox"/>			
			71.6	Load-side encoder normal communication - Transmission data error 2	EDB	<input checked="" type="checkbox"/>	<input type="checkbox"/>			
			71.7	Load-side encoder normal communication - Transmission data error 3	EDB	<input checked="" type="checkbox"/>	<input type="checkbox"/>			
			71.9	Load-side encoder normal communication - Receive data error 4	EDB	<input checked="" type="checkbox"/>	<input type="checkbox"/>			
			71.A	Load-side encoder normal communication - Receive data error 5	EDB	<input checked="" type="checkbox"/>	<input type="checkbox"/>			
	72	Load-side encoder normal communication error 2	72.1	Load-side encoder data error 1	EDB	<input checked="" type="checkbox"/>	<input type="checkbox"/>	1	1	0
			72.2	Load-side encoder data update error	EDB	<input checked="" type="checkbox"/>	<input type="checkbox"/>			
			72.3	Load-side encoder data waveform error	EDB	<input checked="" type="checkbox"/>	<input type="checkbox"/>			
			72.4	Load-side encoder non-signal error	EDB	<input checked="" type="checkbox"/>	<input type="checkbox"/>			
			72.5	Load-side encoder hardware error 1	EDB	<input checked="" type="checkbox"/>	<input type="checkbox"/>			
			72.6	Load-side encoder hardware error 2	EDB	<input checked="" type="checkbox"/>	<input type="checkbox"/>			
			72.9	Load-side encoder data error 2	EDB	<input checked="" type="checkbox"/>	<input type="checkbox"/>			
	74	Option card error 1	74.1	Option card error 1	DB	<input checked="" type="checkbox"/>	<input type="checkbox"/>	<input checked="" type="checkbox"/>	<input checked="" type="checkbox"/>	<input checked="" type="checkbox"/>
			74.2	Option card error 2	DB	<input checked="" type="checkbox"/>	<input type="checkbox"/>	<input checked="" type="checkbox"/>	<input checked="" type="checkbox"/>	<input checked="" type="checkbox"/>
			74.3	Option card error 3	DB	<input checked="" type="checkbox"/>	<input type="checkbox"/>	<input checked="" type="checkbox"/>	<input checked="" type="checkbox"/>	<input checked="" type="checkbox"/>
			74.4	Option card error 4	DB	<input checked="" type="checkbox"/>	<input type="checkbox"/>	<input checked="" type="checkbox"/>	<input checked="" type="checkbox"/>	<input checked="" type="checkbox"/>
			74.5	Option card error 5	DB	<input checked="" type="checkbox"/>	<input type="checkbox"/>	<input checked="" type="checkbox"/>	<input checked="" type="checkbox"/>	<input checked="" type="checkbox"/>
	75	Option card error 2	75.3	Option card connection error	EDB	<input checked="" type="checkbox"/>	<input type="checkbox"/>	<input checked="" type="checkbox"/>	<input checked="" type="checkbox"/>	<input checked="" type="checkbox"/>
			75.4	Option card disconnected	DB	<input checked="" type="checkbox"/>	<input type="checkbox"/>	<input checked="" type="checkbox"/>	<input checked="" type="checkbox"/>	<input checked="" type="checkbox"/>
	79	Functional safety unit diagnosis error	79.1	Functional safety unit power voltage error	DB	<input type="checkbox"/>	<input type="checkbox"/>	1	1	1
			79.2	Functional safety unit internal error	DB	<input checked="" type="checkbox"/>	<input type="checkbox"/>			
			79.3	Abnormal temperature of functional safety unit	SD	<input type="checkbox"/>	<input type="checkbox"/>			
			79.4	Servo amplifier error	SD	<input checked="" type="checkbox"/>	<input type="checkbox"/>			
			79.5	Input device error	SD	<input checked="" type="checkbox"/>	<input type="checkbox"/>			
			79.6	Output device error	SD	<input checked="" type="checkbox"/>	<input type="checkbox"/>			
			79.7	Mismatched input signal error	SD	<input checked="" type="checkbox"/>	<input type="checkbox"/>			
	79.8	Position feedback fixing error	DB	<input checked="" type="checkbox"/>	<input type="checkbox"/>					
	7A	Parameter setting error (safety observation function)	7A.1	Parameter verification error (safety observation function)	DB	<input checked="" type="checkbox"/>	<input type="checkbox"/>	0	0	0
			7A.2	Parameter setting range error (safety observation function)	DB	<input checked="" type="checkbox"/>	<input type="checkbox"/>			
			7A.3	Parameter combination error (safety observation function)	DB	<input checked="" type="checkbox"/>	<input type="checkbox"/>			
7A.4			Functional safety unit combination error (safety observation function)	DB	<input checked="" type="checkbox"/>	<input type="checkbox"/>				

8. TROUBLESHOOTING

	No.	Name	Detail No.	Detail name	Stop Type (Note 2, 3)	Alarm deactivation		Alarm code		
						Alarm reset	Cycling the power	CN1-22 (Bit 2)	CN1-23 (Bit 1)	CN1-24 (Bit 0)
Alarm	7B	Encoder diagnosis error (safety observation function)	7B.1	Encoder diagnosis error 1 (safety observation function)	DB	<input checked="" type="checkbox"/>	<input type="checkbox"/>	1	1	0
			7B.2	Encoder diagnosis error 2 (safety observation function)	DB	<input checked="" type="checkbox"/>	<input type="checkbox"/>			
			7B.3	Encoder diagnosis error 3 (safety observation function)	DB	<input checked="" type="checkbox"/>	<input type="checkbox"/>			
			7B.4	Encoder diagnosis error 4 (safety observation function)	DB	<input checked="" type="checkbox"/>	<input type="checkbox"/>			
	7C	Functional safety unit communication diagnosis error (safety observation function)	7C.1	Functional safety unit communication setting error (safety observation function)	SD	<input type="checkbox"/> (Note 5)	<input type="checkbox"/>	0	0	0
			7C.2	Functional safety unit communication data error (safety observation function)	SD	<input type="checkbox"/> (Note 5)	<input type="checkbox"/>			
	7D	Safety observation error	7D.1	Stop observation error	DB	<input type="checkbox"/> (Note 3)	<input type="checkbox"/>	1	1	1
			7D.2	Speed observation error	DB	<input type="checkbox"/> (Note 5)	<input type="checkbox"/>			
	82	Master-slave operation error 1	82.1	Master-slave operation error 1	EDB	<input type="checkbox"/>	<input type="checkbox"/>	<input checked="" type="checkbox"/>	<input checked="" type="checkbox"/>	<input checked="" type="checkbox"/>
	84	Network module initialization error	84.1	Network module undetected error	DB	<input checked="" type="checkbox"/>	<input type="checkbox"/>	<input checked="" type="checkbox"/>	<input checked="" type="checkbox"/>	<input checked="" type="checkbox"/>
			84.2	Network module initialization error 1	DB	<input checked="" type="checkbox"/>	<input type="checkbox"/>	<input checked="" type="checkbox"/>	<input checked="" type="checkbox"/>	<input checked="" type="checkbox"/>
			84.3	Network module initialization error 2	DB	<input checked="" type="checkbox"/>	<input type="checkbox"/>	<input checked="" type="checkbox"/>	<input checked="" type="checkbox"/>	<input checked="" type="checkbox"/>
	85	Network module error	85.1	Network module error 1	SD	<input checked="" type="checkbox"/>	<input type="checkbox"/>	<input checked="" type="checkbox"/>	<input checked="" type="checkbox"/>	<input checked="" type="checkbox"/>
			85.2	Network module error 2	SD	<input checked="" type="checkbox"/>	<input type="checkbox"/>	<input checked="" type="checkbox"/>	<input checked="" type="checkbox"/>	<input checked="" type="checkbox"/>
			85.3	Network module error 3	SD	<input checked="" type="checkbox"/>	<input type="checkbox"/>	<input checked="" type="checkbox"/>	<input checked="" type="checkbox"/>	<input checked="" type="checkbox"/>
	86	Network communication error	86.1	Network communication error 1	SD	<input type="checkbox"/>	<input type="checkbox"/>	<input checked="" type="checkbox"/>	<input checked="" type="checkbox"/>	<input checked="" type="checkbox"/>
			86.2	Network communication error 2	SD	<input type="checkbox"/>	<input type="checkbox"/>	<input checked="" type="checkbox"/>	<input checked="" type="checkbox"/>	<input checked="" type="checkbox"/>
			86.3	Network communication error 3	SD	<input type="checkbox"/>	<input type="checkbox"/>	<input checked="" type="checkbox"/>	<input checked="" type="checkbox"/>	<input checked="" type="checkbox"/>
	8A	USB communication time-out error/serial communication time-out error/Modbus-RTU communication time-out error	8A.1	USB communication time-out error/Serial communication time-out error	SD	<input type="checkbox"/>	<input type="checkbox"/>	0	0	0
			8A.2	Modbus-RTU communication time-out error	SD	<input type="checkbox"/>	<input type="checkbox"/>			
	8D	CC-Link IE communication error	8D.1	CC-Link IE communication error 1	SD	<input type="checkbox"/>	<input type="checkbox"/>	<input checked="" type="checkbox"/>	<input checked="" type="checkbox"/>	<input checked="" type="checkbox"/>
			8D.2	CC-Link IE communication error 2	SD	<input type="checkbox"/>	<input type="checkbox"/>	<input checked="" type="checkbox"/>	<input checked="" type="checkbox"/>	<input checked="" type="checkbox"/>
			8D.3	Master station setting error 1	DB	<input type="checkbox"/>	<input type="checkbox"/>	<input checked="" type="checkbox"/>	<input checked="" type="checkbox"/>	<input checked="" type="checkbox"/>
			8D.5	Master station setting error 2	DB	<input checked="" type="checkbox"/>	<input type="checkbox"/>	<input checked="" type="checkbox"/>	<input checked="" type="checkbox"/>	<input checked="" type="checkbox"/>
			8D.6	CC-Link IE communication error 3	SD	<input type="checkbox"/>	<input type="checkbox"/>	<input checked="" type="checkbox"/>	<input checked="" type="checkbox"/>	<input checked="" type="checkbox"/>
			8D.7	CC-Link IE communication error 4	SD	<input type="checkbox"/>	<input type="checkbox"/>	<input checked="" type="checkbox"/>	<input checked="" type="checkbox"/>	<input checked="" type="checkbox"/>
			8D.8	CC-Link IE communication error 5	SD	<input type="checkbox"/>	<input type="checkbox"/>	<input checked="" type="checkbox"/>	<input checked="" type="checkbox"/>	<input checked="" type="checkbox"/>
			8D.9	Synchronization error 1	SD	<input checked="" type="checkbox"/>	<input type="checkbox"/>	<input checked="" type="checkbox"/>	<input checked="" type="checkbox"/>	<input checked="" type="checkbox"/>
8D.A			Synchronization error 2	SD	<input checked="" type="checkbox"/>	<input type="checkbox"/>	<input checked="" type="checkbox"/>	<input checked="" type="checkbox"/>	<input checked="" type="checkbox"/>	

8. TROUBLESHOOTING

	No.	Name	Detail No.	Detail name	Stop Type (Note 2, 3)	Alarm deactivation		Alarm code		
						Alarm reset	Cycling the power	CN1-22 (Bit 2)	CN1-23 (Bit 1)	CN1-24 (Bit 0)
Alarm	8E	USB communication error/serial communication error/Modbus-RTU communication error	8E.1	USB communication receive error/Serial communication receive error	SD	○	○	0	0	0
			8E.2	USB communication checksum error/Serial communication checksum error	SD	○	○			
			8E.3	USB communication character error/serial communication character error	SD	○	○			
			8E.4	USB communication command error/Serial communication command error	SD	○	○			
			8E.5	USB communication data number error/Serial communication data number error	SD	○	○			
			8E.6	Modbus-RTU communication receive error	SD	○	○			
			8E.7	Modbus-RTU communication message frame error	SD	○	○			
			8E.8	Modbus-RTU communication CRC error	SD	○	○			
	88888	Watchdog	8888_	Watchdog	DB		○			

Note 1. Leave for about 30 minutes of cooling time after removing the cause of occurrence.

2. The following shows three stop methods of DB, EDB, and SD.

DB: Stops with dynamic brake. (Coasts for the servo amplifier without dynamic brake.)

Coasts for MR-J4-03A6(-RJ).

Note that EDB is applied when an alarm below occurs:

[AL. 30.1], [AL. 32.2], [AL. 32.4], [AL. 51.1], [AL. 51.2]

EDB: Electronic dynamic brake stop (available with specified servo motors)

Refer to the following table for the specified servo motors. The stop method for other than the specified servo motors will be DB.

Series	Servo motor
HG-KR	HG-KR053/HG-KR13/HG-KR23/HG-KR43
HG-MR	HG-MR053/HG-MR13/HG-MR23/HG-MR43
HG-SR	HG-SR51/HG-SR52
HG-AK	HG-AK0136/HG-AK0236/HG-AK0336

SD: Forced stop deceleration

3. This is applicable when [Pr. PA04] is set to the initial value. The stop system of SD can be changed to DB using [Pr. PA04].

4. The alarm can be canceled by setting as follows:

For the fully closed loop control: set [Pr. PE03] to "1 ___".

When a linear servo motor or direct drive motor is used: set [Pr. PL04] to "1 ___".

5. Reset this while all the safety observation functions are stopped.

8. TROUBLESHOOTING

8.3 Warning list

	No.	Name	Detail No.	Detail name	Stop method (Note 2, 3)
Warning	90	Home position return incomplete warning	90.1	Home position return incomplete	
			90.2	Home position return abnormal termination	
			90.5	Z-phase unpassed	
	91	Servo amplifier overheat warning (Note 1)	91.1	Main circuit device overheat warning	
	92	Battery cable disconnection warning	92.1	Encoder battery cable disconnection warning	
			92.3	Battery degradation	
	93	ABS data transfer warning	93.1	Magnetic pole detection incomplete warning at ABS data transfer request	
	95	STO warning	95.1	STO1 off detection	DB
			95.2	STO2 off detection	DB
			95.3	STO warning 1 (safety observation function)	DB
			95.4	STO warning 2 (safety observation function)	DB
			95.5	STO warning 3 (safety observation function)	DB
	96	Home position setting warning	96.1	In-position warning at home positioning	
			96.2	Command input warning at home positioning	
			96.3	Servo off warning at home positioning	
			96.4	Magnetic pole detection incomplete warning at home positioning	
	97	Positioning specification warning	97.1	Program operation disabled warning	
			97.2	Next station position warning	
	98	Software limit warning	98.1	Forward rotation-side software stroke limit reached	
			98.2	Reverse rotation-side software stroke limit reached	
	99	Stroke limit warning	99.1	Forward rotation stroke end off	(Note 4)
			99.2	Reverse rotation stroke end off	(Note 4)
			99.4	Upper stroke limit off	
			99.5	Lower stroke limit off	
	9A	Optional unit input data error warning	9A.1	Optional unit input data sign error	
			9A.2	Optional unit BCD input data error	
	9B	Error excessive warning	9B.1	Excess droop pulse 1 warning	
9B.3			Excess droop pulse 2 warning		
9B.4			Error excessive warning during 0 torque limit		
9C	Converter warning	9C.1	Converter unit warning		
9D	CC-Link IE warning 1	9D.1	Station number switch change warning		
		9D.2	Master station setting warning		
		9D.3	Overlapping station number warning		
		9D.4	Mismatched station number warning		
9E	CC-Link IE warning 2	9E.1	CC-Link IE communication warning		
9F	Battery warning	9F.1	Low battery		
		9F.2	Battery degradation warning		

8. TROUBLESHOOTING

	No.	Name	Detail No.	Detail name	Stop method (Note 2, 3)
Warning	E0	Excessive regeneration warning	E0.1	Excessive regeneration warning	
	E1	Overload warning 1	E1.1	Thermal overload warning 1 during operation	
			E1.2	Thermal overload warning 2 during operation	
			E1.3	Thermal overload warning 3 during operation	
			E1.4	Thermal overload warning 4 during operation	
			E1.5	Thermal overload warning 1 during a stop	
			E1.6	Thermal overload warning 2 during a stop	
			E1.7	Thermal overload warning 3 during a stop	
			E1.8	Thermal overload warning 4 during a stop	
	E2	Servo motor overheat warning	E2.1	Servo motor temperature warning	
	E3	Absolute position counter warning	E3.1	Multi-revolution counter travel distance excess warning	
			E3.2	Absolute position counter warning	
			E3.4	Absolute positioning counter EEPROM writing frequency warning	
			E3.5	Encoder absolute positioning counter warning	
	E4	Parameter warning	E4.1	Parameter setting range error warning	
	E5	ABS time-out warning	E5.1	Time-out during ABS data transfer	
			E5.2	ABSM off during ABS data transfer	
			E5.3	SON off during ABS data transfer	
	E6	Servo forced stop warning	E6.1	Forced stop warning	SD
			E6.2	SS1 forced stop warning 1 (safety observation function)	SD
			E6.3	SS1 forced stop warning 2 (safety observation function)	SD
	E7	Controller forced stop warning	E7.1	Controller forced stop input warning	SD
	E8	Cooling fan speed reduction warning	E8.1	Decreased cooling fan speed warning	
			E8.2	Cooling fan stop	
	E9	Main circuit off warning	E9.1	Servo-on signal on during main circuit off	DB
			E9.2	Bus voltage drop during low speed operation	DB
E9.3			Ready-on signal on during main circuit off	DB	
E9.4			Converter unit forced stop	DB	
EA	ABS servo-on warning	EA.1	ABS servo-on warning		
EB	The other axis error warning	EB.1	The other axis error warning	DB	
EC	Overload warning 2	EC.1	Overload warning 2		
ED	Output watt excess warning	ED.1	Output watt excess warning		
F0	Tough drive warning	F0.1	Instantaneous power failure tough drive warning		
		F0.3	Vibration tough drive warning		

8. TROUBLESHOOTING

	No.	Name	Detail No.	Detail name	Stop method (Note 2, 3)
Warning	F2	Drive recorder - Miswriting warning	F2.1	Drive recorder - Area writing time-out warning	
			F2.2	Drive recorder - Data miswriting warning	
	F3	Oscillation detection warning	F3.1	Oscillation detection warning	
	F4	Positioning warning	F4.4	Target position setting range error warning	
			F4.6	Acceleration time constant setting range error warning	
			F4.7	Deceleration time constant setting range error warning	
	F5	Simple cam function - Cam data miswriting warning	F5.1	Cam data - Area writing time-out warning	
			F5.2	Cam data - Area miswriting warning	
			F5.3	Cam data checksum error	
	F6	Simple cam function - Cam control warning	F6.1	Cam axis one cycle current value restoration failed	
			F6.2	Cam axis feed current value restoration failed	
			F6.3	Cam unregistered error	
			F6.4	Cam control data setting range error	
			F6.5	Cam No. external error	
F6.6			Cam control inactive		

- Note
1. Leave for about 30 minutes of cooling time after removing the cause of occurrence.
 2. The following shows two stop methods of DB and SD.
 DB: Stops with dynamic brake. (Coasts for the servo amplifier without dynamic brake.)
 Coasts for MR-J4-03A6(-RJ).
 SD: Forced stop deceleration
 3. This is applicable when [Pr. PA04] is set to the initial value. The stop system of SD can be changed to DB using [Pr. PA04].
 4. Quick stop or slow stop can be selected using [Pr. PD30].

9. OPTIONS AND PERIPHERAL EQUIPMENT

9. OPTIONS AND PERIPHERAL EQUIPMENT



WARNING

● Before connecting any option or peripheral equipment, turn off the power and wait for 15 minutes or more until the charge lamp turns off. Then, confirm that the voltage between P+ and N- is safe with a voltage tester and others. Otherwise, an electric shock may occur. In addition, when confirming whether the charge lamp is off or not, always confirm it from the front of the servo amplifier.



CAUTION

● Use the specified peripheral equipment and options to prevent a malfunction or a fire.

The following items are the same as MR-J4- _A_ -RJ servo amplifiers. For details, refer to each section indicated in the detailed explanation field. "MR-J4- _A_" means "MR-J4- _A_ (-RJ) Servo Amplifier Instruction Manual".

Item	Detailed explanation	
	MR-J4- _A_ -RJ 100 W or more	MR-J4-03A6-RJ
Cable/connector sets	MR-J4- _A_ section 11.1	MR-J4- _A_ section 18.8.1
Regenerative option	MR-J4- _A_ section 11.2	
FR-BU2- (H) brake unit	MR-J4- _A_ section 11.3	
FR-RC-(H) power regeneration converter	MR-J4- _A_ section 11.4	
FR-CV-(H) power regeneration common converter	MR-J4- _A_ section 11.5	
Junction terminal block MR-TB50 (recommended)	MR-J4- _A_ section 11.6	
MR Configurator2	MR-J4- _A_ section 11.7	
Battery	MR-J4- _A_ section 11.8	
Selection example of wires	MR-J4- _A_ section 11.9	MR-J4- _A_ section 18.8.3
Molded-case circuit breakers, fuses, magnetic contactors	MR-J4- _A_ section 11.10	
Power factor improving DC reactor	MR-J4- _A_ section 11.11	
Power factor improving AC reactor	MR-J4- _A_ section 11.12	
Relay (recommended)	MR-J4- _A_ section 11.13	
Noise reduction techniques	MR-J4- _A_ section 11.14	
Earth-leakage current breaker	MR-J4- _A_ section 11.15	
EMC filter (recommended)	MR-J4- _A_ section 11.16	
External dynamic brake	MR-J4- _A_ section 11.17	
Panel through attachment (MR-J4ACN15K/MR-J3ACN)	MR-J4- _A_ section 11.18	
Circuit protector		MR-J4- _A_ section 18.8.4

9. OPTIONS AND PERIPHERAL EQUIPMENT

9.1 MR-HDP01 manual pulse generator

POINT
<ul style="list-style-type: none"> ● When using an MR-HDP01, set [Pr. PA13 Command pulse input form] to "_ 2 _ 2" or "_ 3 _ 2". ● Configure MR-HDP01 with sink interface.

You can operate servo motors by using MR-HDP01 manual pulse generator. A multiplication to pulse signals which MR-HDP01 generates with external input signals can be changed with TP0 (Manual pulse generator multiplication 1) and TP1 (Manual pulse generator multiplication 2).

(1) Specifications

Item	Specifications	
Power supply	Voltage	4.5 V DC to 13.2 V DC
	Consumption current	60 mA or less
Interface	Maximum output current: 20 mA for open collector output	
Pulse signal form	A-phase/B-phase, 2 signals of 90° phase difference	
Pulse resolution	100 pulses/rev	
Maximum speed	Instantaneous maximum: 600 r/min, normal: 200 r/min	
Temperature range for operation	-10 °C to 60 °C	
Temperature range for storage	-30 °C to 80 °C	

(2) Connection example

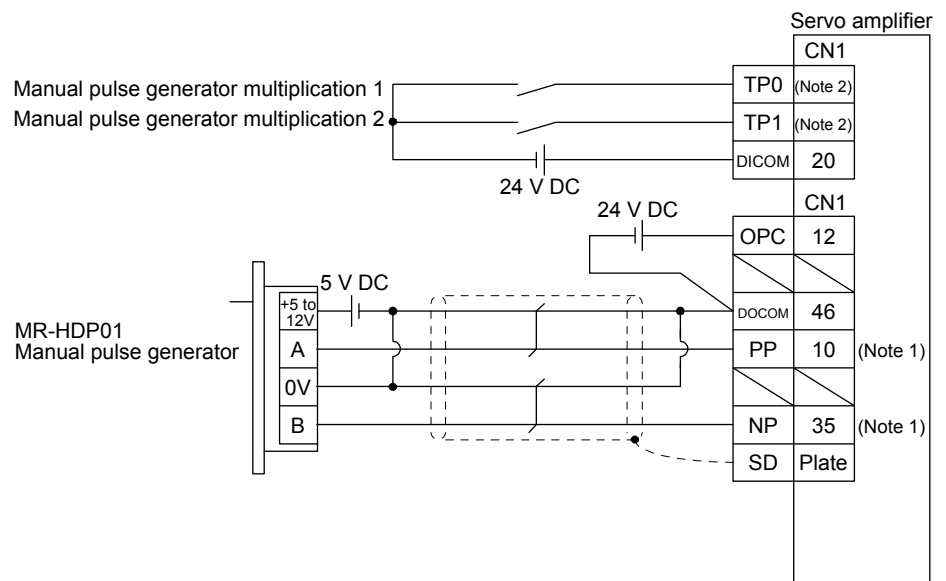

- Note 1. To assign PP and NP, set [Pr. PD44] and [Pr. PD46] to "0 0 _ _".
 Note 2. To use this as an input device, assign to specified pin of the CN1 connector with [Pr. PD04] to [Pr. PD22].

9. OPTIONS AND PERIPHERAL EQUIPMENT

(3) Terminal assignment

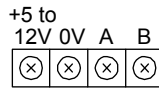

Signal name	Description
+5 to 12V	Power supply input
0V	Common for power and signal
A	A-phase output pulse
B	B-phase output pulse

(4) Mounting

[Unit: mm]

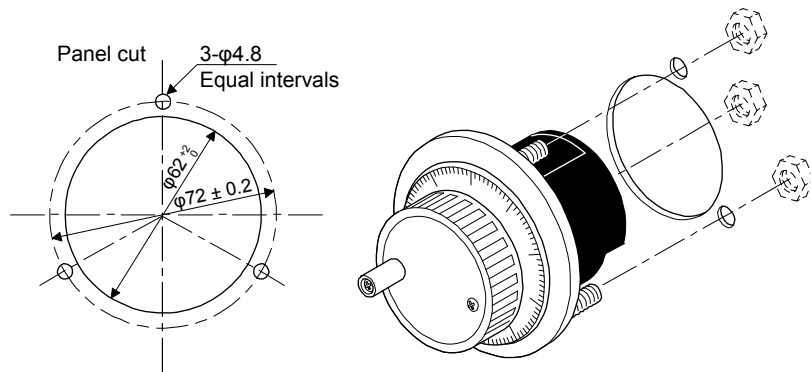

(5) Dimensions

[Unit: mm]

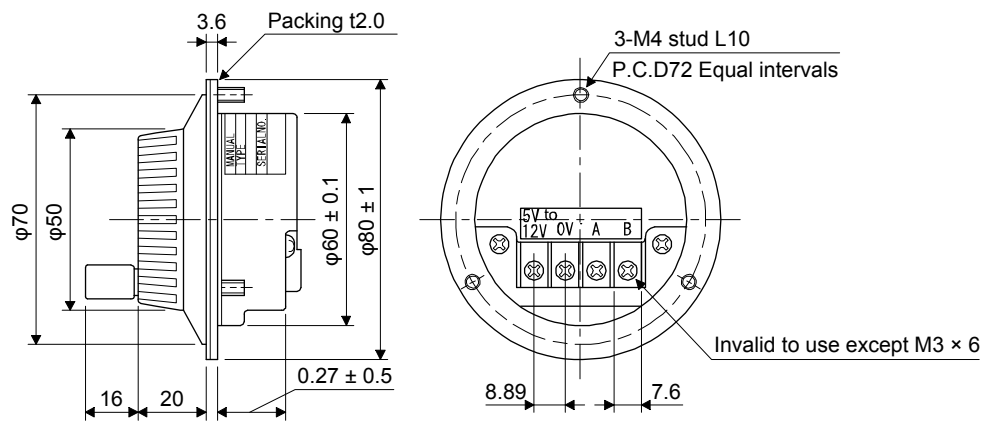

10. COMMUNICATION FUNCTION (MITSUBISHI GENERAL-PURPOSE AC SERVO PROTOCOL)

The following items are the same as those of MR-J4- _A_-RJ servo amplifiers. For details, refer to each section indicated in the detailed explanation field. "MR-J4- _A_" means "MR-J4- _A_-(-RJ) Servo Amplifier Instruction Manual".

Item	Detailed explanation	
	MR-J4- _A_-RJ 100 W or more	MR-J4-03A6-RJ
Structure	MR-J4- _A_ section 14.1	MR-J4- _A_ section 18.9
Communication specifications	MR-J4- _A_ section 14.2	
Protocol	MR-J4- _A_ section 14.3	
Data processing	MR-J4- _A_ section 14.5.1	
Status display	MR-J4- _A_ section 14.5.2	
Parameter	MR-J4- _A_ section 14.5.3	
Prohibiting/canceling I/O devices (DIO)	MR-J4- _A_ section 14.5.6	
Alarm history	MR-J4- _A_ section 14.5.10	
Current alarm	MR-J4- _A_ section 14.5.11	
Other commands	MR-J4- _A_ section 14.5.12	

POINT	<ul style="list-style-type: none"> ● Creating and reading programs are not available with Mitsubishi general-purpose AC servo protocol (RS-422 communication). Use MR Configurator2. ● A personal computer cannot be connected to the CN30 connector of MR-D01.
-------	---

10.1 Command and data No. list

POINT	<ul style="list-style-type: none"> ● Even if a command or data No. is the same between different model servo amplifiers, its description may differ. ● The symbols in the control mode column mean as follows. <ul style="list-style-type: none"> CP: Positioning mode (point table method) BCD: Positioning mode (point table method in the BCD input positioning operation) This method is available only when the MR-D01 unit is connected. Refer to chapter 12 for details. CL: Positioning mode (program method) PS: Positioning mode (indexer method)
-------	--

10. COMMUNICATION FUNCTION (MITSUBISHI GENERAL-PURPOSE AC SERVO PROTOCOL)

10.1.1 Reading command

(1) Status display (command [0] [1])

Command	Data No.	Description	Status display	Control mode			Frame length
				CP/BCD	CL	PS	
[0] [1]	[0] [0]	Status display symbol and unit	Cumulative feedback pulses Servo motor-side cumulative feedback pulses (after gear)	○	○	○	16
	[0] [1]		Servo motor speed Servo motor speed	○	○	○	
	[0] [2]		Droop pulses Servo motor-side droop pulses	○	○	○	
	[0] [3]		Cumulative command pulses	△	△	△	
	[0] [4]		Command pulse frequency	△	△	△	
	[0] [5]		Analog speed command voltage Analog speed limit voltage	△	△	△	
	[0] [6]		Analog torque limit voltage Analog torque command voltage	△	△	△	
	[0] [7]		Regenerative load ratio	○	○	○	
	[0] [8]		Effective load ratio	○	○	○	
	[0] [9]		Peak load ratio	○	○	○	
	[0] [A]		Instantaneous torque Instantaneous thrust	○	○	○	
	[0] [B]		Position within one-revolution Servo motor encoder position within one-revolution Virtual position within one-revolution	○	○	○	
	[0] [C]		ABS counter Servo motor encoder ABS counter Virtual ABS counter	○	○	○	
	[0] [D]		Load to motor inertia ratio Load to motor mass ratio	○	○	○	
	[0] [E]		Bus voltage	○	○	○	
	[0] [F] (Note)		Load-side cumulative feedback pulses	○	○	○	
	[1] [0] (Note)		Load-side droop pulses	○	○	○	
	[1] [1] (Note)		Load-side encoder information 1 Z-phase counter	○	○	○	
	[1] [2] (Note)		Load-side encoder information 2	○	○	○	
	[1] [6] (Note)		Temperature of servo motor thermistor	○	○	○	
	[1] [7] (Note)		Servo motor-side cumulative feedback pulses (before gear)	○	○	○	
	[1] [8] (Note)		Electrical angle	○	○	○	
	[1] [E] (Note)		Servo motor-side/load-side position deviation	○	○	○	
	[1] [F] (Note)		Servo motor-side/load-side speed deviation	○	○	○	
	[2] [0]		Internal temperature of encoder	○	○	○	
	[2] [1]		Settling time	○	○	○	
	[2] [2]		Oscillation detection frequency	○	○	○	
	[2] [3]		Number of tough drive operations	○	○	○	
	[2] [8]		Unit power consumption	○	○	○	
	[2] [9]		Unit total power consumption	○	○	○	
	[2] [A]		Current position	○	○	△	
	[2] [B]		Command position	○	○	△	
	[2] [C]		Command remaining distance	○	○	○	
	[2] [D]		Point table No./Program No./Station position No.	○	○	○	

Note. This is not available with the MR-J4-03A6-RJ servo amplifier.

10. COMMUNICATION FUNCTION (MITSUBISHI GENERAL-PURPOSE AC SERVO PROTOCOL)

Command	Data No.	Description	Status display	Control mode			Frame length		
				CP/BCD	CI	P/S			
[0] [1]	[2] [E]	Status display symbol and unit	Step No.	<input type="checkbox"/>	<input type="checkbox"/>	<input type="checkbox"/>	16		
	[2] [F]		Analog override voltage	<input type="checkbox"/>	<input type="checkbox"/>	<input type="checkbox"/>			
	[3] [0]		Override level	<input type="checkbox"/>	<input type="checkbox"/>	<input type="checkbox"/>			
	[3] [3]		Cam axis one cycle current value	<input type="checkbox"/>	<input type="checkbox"/>	<input type="checkbox"/>			
	[3] [4]		Cam standard position	<input type="checkbox"/>	<input type="checkbox"/>	<input type="checkbox"/>			
	[3] [5]		Cam axis feed current value	<input type="checkbox"/>	<input type="checkbox"/>	<input type="checkbox"/>			
	[3] [6]		Cam No. in execution	<input type="checkbox"/>	<input type="checkbox"/>	<input type="checkbox"/>			
	[3] [7]		Cam stroke amount in execution	<input type="checkbox"/>	<input type="checkbox"/>	<input type="checkbox"/>			
	[3] [8]		Main axis current value	<input type="checkbox"/>	<input type="checkbox"/>	<input type="checkbox"/>			
	[3] [9]		Main axis one cycle current value	<input type="checkbox"/>	<input type="checkbox"/>	<input type="checkbox"/>			
	[8] [0]		Status display data value and processing information	Cumulative feedback pulses Servo motor-side cumulative feedback pulses (after gear)	<input type="checkbox"/>	<input type="checkbox"/>		<input type="checkbox"/>	12
	[8] [1]			Servo motor speed Servo motor speed	<input type="checkbox"/>	<input type="checkbox"/>		<input type="checkbox"/>	
[8] [2]	Droop pulses Servo motor-side droop pulses	<input type="checkbox"/>		<input type="checkbox"/>	<input type="checkbox"/>				
[8] [3]	Cumulative command pulses	<input type="checkbox"/>		<input type="checkbox"/>	<input type="checkbox"/>				
[8] [4]	Command pulse frequency	<input type="checkbox"/>		<input type="checkbox"/>	<input type="checkbox"/>				
[8] [5]	Analog speed command voltage Analog speed limit voltage	<input type="checkbox"/>		<input type="checkbox"/>	<input type="checkbox"/>				
[8] [6]	Analog torque limit voltage Analog torque command voltage	<input type="checkbox"/>		<input type="checkbox"/>	<input type="checkbox"/>				
[8] [7]	Regenerative load ratio	<input type="checkbox"/>		<input type="checkbox"/>	<input type="checkbox"/>				
[8] [8]	Effective load ratio	<input type="checkbox"/>		<input type="checkbox"/>	<input type="checkbox"/>				
[8] [9]	Peak load ratio	<input type="checkbox"/>		<input type="checkbox"/>	<input type="checkbox"/>				
[8] [A]	Instantaneous torque Instantaneous thrust	<input type="checkbox"/>		<input type="checkbox"/>	<input type="checkbox"/>				
[8] [B]	Position within one-revolution Servo motor encoder position within one-revolution Virtual position within one-revolution	<input type="checkbox"/>		<input type="checkbox"/>	<input type="checkbox"/>				
[8] [C]	ABS counter Servo motor encoder ABS counter Virtual ABS counter	<input type="checkbox"/>		<input type="checkbox"/>	<input type="checkbox"/>				
[8] [D]	Load to motor inertia ratio Load to motor mass ratio	<input type="checkbox"/>		<input type="checkbox"/>	<input type="checkbox"/>				
[8] [E]	Bus voltage	<input type="checkbox"/>		<input type="checkbox"/>	<input type="checkbox"/>				
[8] [F] (Note)	Load-side cumulative feedback pulses	<input type="checkbox"/>		<input type="checkbox"/>	<input type="checkbox"/>				
[9] [0] (Note)	Load-side droop pulses	<input type="checkbox"/>		<input type="checkbox"/>	<input type="checkbox"/>				
[9] [1] (Note)	Load-side encoder information 1 Z-phase counter	<input type="checkbox"/>		<input type="checkbox"/>	<input type="checkbox"/>				
[9] [2] (Note)	Load-side encoder information 2	<input type="checkbox"/>		<input type="checkbox"/>	<input type="checkbox"/>				
[9] [6] (Note)	Temperature of servo motor thermistor	<input type="checkbox"/>		<input type="checkbox"/>	<input type="checkbox"/>				
[9] [7] (Note)	Servo motor-side cumulative feedback pulses (before gear)	<input type="checkbox"/>		<input type="checkbox"/>	<input type="checkbox"/>				
[9] [8] (Note)	Electrical angle	<input type="checkbox"/>		<input type="checkbox"/>	<input type="checkbox"/>				
[9] [E] (Note)	Servo motor-side/load-side position deviation	<input type="checkbox"/>		<input type="checkbox"/>	<input type="checkbox"/>				
[9] [F] (Note)	Servo motor-side/load-side speed deviation	<input type="checkbox"/>		<input type="checkbox"/>	<input type="checkbox"/>				
[A] [0]	Internal temperature of encoder	<input type="checkbox"/>		<input type="checkbox"/>	<input type="checkbox"/>				
[A] [1]	Settling time	<input type="checkbox"/>		<input type="checkbox"/>	<input type="checkbox"/>				
[A] [2]	Oscillation detection frequency	<input type="checkbox"/>		<input type="checkbox"/>	<input type="checkbox"/>				

Note. This is not available with the MR-J4-03A6-RJ servo amplifier.

10. COMMUNICATION FUNCTION (MITSUBISHI GENERAL-PURPOSE AC SERVO PROTOCOL)

Command	Data No.	Description	Status display	Control mode			Frame length
				CP/BCD	Cl	P/S	
[0] [1]	[A] [3]	Status display data value and processing information	Number of tough drive operations	○	○	○	12
	[A] [8]		Unit power consumption	○	○	○	
	[A] [9]		Unit total power consumption	○	○	○	
	[A] [A]		Current position	○	○	△	
	[A] [B]		Command position	○	○	△	
	[A] [C]		Command remaining distance	○	○	○	
	[A] [D]		Point table No./Program No./ Station position No.	○	○	○	
	[A] [E]		Step No.	△	○	△	
	[A] [F]		Analog override voltage	○	○	○	
	[B] [0]		Override level	○	○	○	
	[B] [3]		Cam axis one cycle current value	○	○	△	
	[B] [4]		Cam standard position	○	○	△	
	[B] [5]		Cam axis feed current value	○	○	△	
	[B] [6]		Cam No. in execution	○	○	△	
	[B] [7]		Cam stroke amount in execution	○	○	△	
	[B] [8]		Main axis current value	○	○	△	
	[B] [9]		Main axis one cycle current value	○	○	△	

(2) Parameter (command [0] [4], [1] [5], [1] [6], [1] [7], [0] [8], and [0] [9])

Command	Data No.	Description	Control mode			Frame length
			CP/BCD	Cl	P/S	
[0] [4]	[0] [1]	Reading parameter group 0000: Basic setting parameters ([Pr. PA_ _]) 0001: Gain/filter parameters ([Pr. PB_ _]) 0002: Extension setting parameters ([Pr. PC_ _]) 0003: I/O setting parameters ([Pr. PD_ _]) 0004: Extension setting 2 parameters ([Pr. PE_ _]) 0005: Extension setting 3 parameters ([Pr. PF_ _]) 0009: Option setting parameters ([Pr. Po_ _]) 000B: Linear servo motor/DD motor setting parameters ([Pr. PL_ _]) (Note) 000C: Positioning control parameters ([Pr. PT_ _]) Reads the parameter group specified with the command [8] [5] + data No. [0] [0]. Before reading the current values, therefore, always specify the parameter group with the command [8] [5] + data No. [0] [0].	○	○	○	4
[1] [5]	[0] [1] to [F] [F]	Current value of each parameter Reads the current values of the parameters in the parameter group specified with the command [8] [5] + data No. [0] [0]. Before reading the current values, therefore, always specify the parameter group with the command [8] [5] + data No. [0] [0]. The decimal equivalent of the data No. (hexadecimal) value corresponds to the parameter No.	○	○	○	12
[1] [6]	[0] [1] to [F] [F]	Upper limit value of each parameter setting range Reads the permissible upper limit values of the parameters in the parameter group specified with the command [8] [5] + data No. [0] [0]. Before reading the upper limit values, therefore, always specify the parameter group with the command [8] [5] + data No. [0] [0]. The decimal equivalent of the data No. (hexadecimal) value corresponds to the parameter No.	○	○	○	

10. COMMUNICATION FUNCTION (MITSUBISHI GENERAL-PURPOSE AC SERVO PROTOCOL)

Command	Data No.	Description	Control mode			Frame length
			CP/BCD	CL	P/S	
[1] [7]	[0] [1] to [F] [F]	Lower limit value of each parameter setting range Reads the permissible lower limit values of the parameters in the parameter group specified with the command [8] [5] + data No. [0] [0]. Before reading the lower limit values, therefore, always specify the parameter group with the command [8] [5] + data No. [0] [0]. The decimal equivalent of the data No. (hexadecimal) value corresponds to the parameter No.	○	○	○	12
[0] [8]	[0] [1] to [F] [F]	Each parameter symbol Reads the symbols of the parameters in the parameter group specified with the command [8] [5] + data No. [0] [0]. Before reading the symbols, therefore, always specify the parameter group with the command [8] [5] + data No. [0] [0]. The decimal equivalent of the data No. (hexadecimal) value corresponds to the parameter No.	○	○	○	
[0] [9]	[0] [1] to [F] [F]	Writing enable/disable of parameters Reads writing enable/disable of the parameters in the parameter group specified with the command [8] [5] + data No. [0] [0]. Before reading writing enable/disable, therefore, always specify the parameter group with the command [8] [5] + data No. [0] [0]. 0000: Writing enabled 0001: Writing disabled	○	○	○	4

Note. This is not available with the MR-J4-03A6-RJ servo amplifier.

(3) External I/O signals (command [1] [2])

Command	Data No.	Description	Control mode			Frame length
			CP/BCD	CL	P/S	
[1] [2]	[0] [0] to [0] [2]	Input device status	○	○	○	8
	[4] [0]	External input pin status	○	○	○	
	[6] [0] to [6] [2]	Status of input device turned on by communication	○	○	○	
	[8] [0] to [8] [3]	Output device status	○	○	○	
	[C] [0]	External output pin status	○	○	○	

(4) Current position latch display (command [1] [A])

Command	Data No.	Description	Control mode			Frame length
			CP/BCD	CL	P/S	
[1] [A]	[0] [0]	MSD (Mark detection) rising latch data (data part)	○	○	△	8
	[0] [1]	MSD (Mark detection) falling latch data (data part)	○	○	△	
	[0] [2]	MSD (Mark detection) rising latch data (data part + additional information)	○	○	△	12 or less
	[0] [3]	MSD (Mark detection) falling latch data (data part + additional information)	○	○	△	

10. COMMUNICATION FUNCTION (MITSUBISHI GENERAL-PURPOSE AC SERVO PROTOCOL)

(5) Alarm history (command [3] [3])

Command	Data No.	Description	Alarm occurrence sequence	Control mode			Frame length
				CP/BCD	CL	PS	
[3] [3]	[1] [0]	Alarm No. in alarm history	Most recent alarm	○	○	○	4
	[1] [1]		First alarm in past	○	○	○	
	[1] [2]		Second alarm in past	○	○	○	
	[1] [3]		Third alarm in past	○	○	○	
	[1] [4]		Fourth alarm in past	○	○	○	
	[1] [5]		Fifth alarm in past	○	○	○	
	[1] [6]		Sixth alarm in past	○	○	○	
	[1] [7]		Seventh alarm in past	○	○	○	
	[1] [8]		Eighth alarm in past	○	○	○	
	[1] [9]		Ninth alarm in past	○	○	○	
	[1] [A]		Tenth alarm in past	○	○	○	
	[1] [B]		Eleventh alarm in past	○	○	○	
	[1] [C]		Twelfth alarm in past	○	○	○	
	[1] [D]		Thirteenth alarm in past	○	○	○	
	[1] [E]		Fourteenth alarm in past	○	○	○	
	[1] [F]		Fifteenth alarm in past	○	○	○	
[2] [0]	[2] [0]	Alarm occurrence time in alarm history	Most recent alarm	○	○	○	8
	[2] [1]		First alarm in past	○	○	○	
	[2] [2]		Second alarm in past	○	○	○	
	[2] [3]		Third alarm in past	○	○	○	
	[2] [4]		Fourth alarm in past	○	○	○	
	[2] [5]		Fifth alarm in past	○	○	○	
	[2] [6]		Sixth alarm in past	○	○	○	
	[2] [7]		Seventh alarm in past	○	○	○	
	[2] [8]		Eighth alarm in past	○	○	○	
	[2] [9]		Ninth alarm in past	○	○	○	
	[2] [A]		Tenth alarm in past	○	○	○	
	[2] [B]		Eleventh alarm in past	○	○	○	
	[2] [C]		Twelfth alarm in past	○	○	○	
	[2] [D]		Thirteenth alarm in past	○	○	○	
	[2] [E]		Fourteenth alarm in past	○	○	○	
	[2] [F]		Fifteenth alarm in past	○	○	○	

(6) Current alarm (command [0] [2])

Command	Data No.	Description	Control mode			Frame length
			CP/BCD	CL	PS	
[0] [2]	[0] [0]	Current alarm No.	○	○	○	4

10. COMMUNICATION FUNCTION (MITSUBISHI GENERAL-PURPOSE AC SERVO PROTOCOL)

(7) Status display at alarm occurrence (command [3] [5])

Command	Data No.	Description	Status display	Control mode			Frame length
				CP/BCD	CL	PS	
[3] [5]	[0] [0]	Status display symbol and unit	Cumulative feedback pulses Servo motor-side cumulative feedback pulses (after gear)	○	○	○	16
	[0] [1]		Servo motor speed Servo motor speed	○	○	○	
	[0] [2]		Droop pulses Servo motor-side droop pulses	○	○	○	
	[0] [3]		Cumulative command pulses	△	△	△	
	[0] [4]		Command pulse frequency	△	△	△	
	[0] [5]		Analog speed command voltage Analog speed limit voltage	△	△	△	
	[0] [6]		Analog torque limit voltage Analog torque command voltage	△	△	△	
	[0] [7]		Regenerative load ratio	○	○	○	
	[0] [8]		Effective load ratio	○	○	○	
	[0] [9]		Peak load ratio	○	○	○	
	[0] [A]		Instantaneous torque Instantaneous thrust	○	○	○	
	[0] [B]		Position within one-revolution Servo motor encoder position within one-revolution Virtual position within one-revolution	○	○	○	
	[0] [C]		ABS counter Servo motor encoder ABS counter Virtual ABS counter	○	○	○	
	[0] [D]		Load to motor inertia ratio Load to motor mass ratio	○	○	○	
	[0] [E]		Bus voltage	○	○	○	
	[0] [F] (Note)		Load-side cumulative feedback pulses	○	○	○	
	[1] [0] (Note)		Load-side droop pulses	○	○	○	
	[1] [1] (Note)		Load-side encoder information 1 Z-phase counter	○	○	○	
	[1] [2] (Note)		Load-side encoder information 2	○	○	○	
	[1] [6] (Note)		Temperature of servo motor thermistor	○	○	○	
	[1] [7] (Note)		Servo motor-side cumulative feedback pulses (before gear)	○	○	○	
	[1] [8] (Note)		Electrical angle	○	○	○	
	[1] [E] (Note)		Servo motor-side/load-side position deviation	○	○	○	
	[1] [F] (Note)		Servo motor-side/load-side speed deviation	○	○	○	
	[2] [0]		Internal temperature of encoder	○	○	○	
	[2] [1]		Settling time	○	○	○	
	[2] [2]		Oscillation detection frequency	○	○	○	
	[2] [3]		Number of tough drive operations	○	○	○	
	[2] [8]		Unit power consumption	○	○	○	
	[2] [9]		Unit total power consumption	○	○	○	
	[2] [A]		Current position	○	○	△	
	[2] [B]		Command position	○	○	△	
	[2] [C]		Command remaining distance	○	○	○	
	[2] [D]		Point table No./Program No./ Station position No.	○	○	○	

Note. This is not available with the MR-J4-03A6-RJ servo amplifier.

10. COMMUNICATION FUNCTION (MITSUBISHI GENERAL-PURPOSE AC SERVO PROTOCOL)

Command	Data No.	Description	Status display	Control mode			Frame length		
				CP/BCD	CL	PS			
[3] [5]	[2] [E]	Status display symbol and unit	Step No.	○	○	○	16		
	[2] [F]		Analog override voltage	○	○	○			
	[3] [0]		Override level	○	○	○			
	[3] [3]		Cam axis one cycle current value	○	○	○			
	[3] [4]		Cam standard position	○	○	○			
	[3] [5]		Cam axis feed current value	○	○	○			
	[3] [6]		Cam No. in execution	○	○	○			
	[3] [7]		Cam stroke amount in execution	○	○	○			
	[3] [8]		Main axis current value	○	○	○			
	[3] [9]		Main axis one cycle current value	○	○	○			
	[8] [0]		Status display data value and processing information	Cumulative feedback pulses Servo motor-side cumulative feedback pulses (after gear)	○	○		○	12
	[8] [1]			Servo motor speed Servo motor speed	○	○		○	
[8] [2]	Droop pulses Servo motor-side droop pulses	○		○	○				
[8] [3]	Cumulative command pulses	○		○	○				
[8] [4]	Command pulse frequency	○		○	○				
[8] [5]	Analog speed command voltage Analog speed limit voltage	○		○	○				
[8] [6]	Analog torque limit voltage Analog torque command voltage	○		○	○				
[8] [7]	Regenerative load ratio	○		○	○				
[8] [8]	Effective load ratio	○		○	○				
[8] [9]	Peak load ratio	○		○	○				
[8] [A]	Instantaneous torque Instantaneous thrust	○		○	○				
[8] [B]	Position within one-revolution Servo motor encoder position within one-revolution Virtual position within one-revolution	○		○	○				
[8] [C]	ABS counter Servo motor encoder ABS counter Virtual ABS counter	○		○	○				
[8] [D]	Load to motor inertia ratio Load to motor mass ratio	○		○	○				
[8] [E]	Bus voltage	○		○	○				
[8] [F] (Note)	Load-side cumulative feedback pulses	○		○	○				
[9] [0] (Note)	Load-side droop pulses	○		○	○				
[9] [1] (Note)	Load-side encoder information 1 Z-phase counter	○		○	○				
[9] [2] (Note)	Load-side encoder information 2	○		○	○				
[9] [6] (Note)	Temperature of servo motor thermistor	○		○	○				
[9] [7] (Note)	Servo motor-side cumulative feedback pulses (before gear)	○		○	○				
[9] [8] (Note)	Electrical angle	○		○	○				
[9] [E] (Note)	Servo motor-side/load-side position deviation	○		○	○				
[9] [F] (Note)	Servo motor-side/load-side speed deviation	○		○	○				
[A] [0]	Internal temperature of encoder	○		○	○				
[A] [1]	Settling time	○		○	○				

Note. This is not available with the MR-J4-03A6-RJ servo amplifier.

10. COMMUNICATION FUNCTION (MITSUBISHI GENERAL-PURPOSE AC SERVO PROTOCOL)

Command	Data No.	Description	Status display	Control mode			Frame length
				CP/BCD	CL	PS	
[3] [5]	[A] [2]	Status display data value and processing information	Oscillation detection frequency	○	○	○	12
	[A] [3]		Number of tough drive operations	○	○	○	
	[A] [8]		Unit power consumption	○	○	○	
	[A] [9]		Unit total power consumption	○	○	○	
	[A] [A]		Current position	○	○	△	
	[A] [B]		Command position	○	○	△	
	[A] [C]		Command remaining distance	○	○	○	
	[A] [D]		Point table No./Program No./ Station position No.	○	○	○	
	[A] [E]		Step No.	△	○	△	
	[A] [F]		Analog override voltage	○	○	○	
	[B] [0]		Override level	○	○	○	
	[B] [3]		Cam axis one cycle current value	○	○	△	
	[B] [4]		Cam standard position	○	○	△	
	[B] [5]		Cam axis feed current value	○	○	△	
	[B] [6]		Cam No. in execution	○	○	△	
	[B] [7]		Cam stroke amount in execution	○	○	△	
	[B] [8]		Main axis current value	○	○	△	
	[B] [9]		Main axis one cycle current value	○	○	△	

(8) Point table setting data (command [4] [0], [4] [5], [5] [0], [5] [4], [5] [8], [6] [0], [6] [4])

Command	Data No.	Description	Control mode			Frame length
			CP/BCD	CL	PS	
[4] [0]	[0] [0] to [F] [F]	Reading position data of each point table The decimal equivalent of the data No. value (hexadecimal) corresponds to the point table No.	○	△	△	8
[4] [5]	[0] [0] to [F] [F]	Reading M code of each point table The decimal equivalent of the data No. value (hexadecimal) corresponds to the point table No.	○	△	△	
[5] [0]	[0] [0] to [F] [F]	Reading speed data of each point table The decimal equivalent of the data No. value (hexadecimal) corresponds to the point table No.	○	△	△	
[5] [4]	[0] [0] to [F] [F]	Reading acceleration time constant of each point table The decimal equivalent of the data No. value (hexadecimal) corresponds to the point table No.	○	△	△	
[5] [8]	[0] [0] to [F] [F]	Reading deceleration time constant of each point table The decimal equivalent of the data No. value (hexadecimal) corresponds to the point table No.	○	△	△	
[6] [0]	[0] [0] to [F] [F]	Reading dwell of each point table The decimal equivalent of the data No. value (hexadecimal) corresponds to the point table No.	○	△	△	
[6] [4]	[0] [0] to [F] [F]	Reading auxiliary function of each point table The decimal equivalent of the data No. value (hexadecimal) corresponds to the point table No.	○	△	△	

10. COMMUNICATION FUNCTION (MITSUBISHI GENERAL-PURPOSE AC SERVO PROTOCOL)

(9) Position data unit/Current position latch data (command [6] [C])

Command	Data No.	Description	Control mode			Frame length
			CP/BCD	CL	PS	
[6] [C]	[0] [0]	Reading position data unit ___ x 0: mm, 1: inch, 2: pulse, 3: degree __ x _ 0: Enabled, 1: Disabled	○	○	○	4
	[0] [1]	Reading current position latch data Reads data latched at rising edge of LPS signal using LPOS command in the program operation.	○	○	○	12

(10) General purpose register (Rx) value (command [6] [D])

Command	Data No.	Description	Control mode			Frame length
			CP/BCD	CL	PS	
[6] [D]	[0] [1]	Reading general purpose register (R1) value	○	○	○	8
	[0] [2]	Reading general purpose register (R2) value	○	○	○	
	[0] [3]	Reading general purpose register (R3) value	○	○	○	
	[0] [4]	Reading general purpose register (R4) value	○	○	○	

(11) General purpose register (Dx) value (command [6] [E])

Command	Data No.	Description	Control mode			Frame length
			CP/BCD	CL	PS	
[6] [E]	[0] [1]	Reading general purpose register (D1) value	○	○	○	8
	[0] [2]	Reading general purpose register (D2) value	○	○	○	
	[0] [3]	Reading general purpose register (D3) value	○	○	○	
	[0] [4]	Reading general purpose register (D4) value	○	○	○	

(12) General purpose register number (command [6] [F])

Command	Data No.	Description	Control mode			Frame length
			CP/BCD	CL	PS	
[6] [F]	[0] [0]	Reading general purpose register (Rx) number	○	○	○	8
	[0] [1]	Reading general purpose register (Dx) number	○	○	○	

10. COMMUNICATION FUNCTION (MITSUBISHI GENERAL-PURPOSE AC SERVO PROTOCOL)

(13) Others (command [0] [0], [0] [2])

Command	Data No.	Description	Control mode			Frame length
			CP/BCD	CL	PS	
[0] [0]	[1] [2]	Reading test operation mode 0000: Normal mode (not test operation mode) 0001: JOG operation 0002: Positioning operation 0004: Output signal (DO) forced output 0005: Single-step feed operation	○	○	○ (Note)	4
	[1] [D]	Reading EEPROM stored data type 0000: Initial state 0001: Point table method 0002: Program method	○	○	○	
	[1] [E]	Reading control mode 0006: Positioning mode (point table method) 0007: Positioning mode (program method) 0008: Positioning mode (indexer method)	○	○	○	
[0] [2]	[9] [0]	Servo motor-side pulse unit absolute position	○	○	○	8
	[9] [1]	Command unit absolute position	○	○	○	
	[7] [0]	Software version	○	○	○	16

Note. "0005 (single-step feed operation)" is not available in the indexer method.

10. COMMUNICATION FUNCTION (MITSUBISHI GENERAL-PURPOSE AC SERVO PROTOCOL)

10.1.2 Writing commands

(1) Status display (command [8] [1])

Command	Data No.	Description	Setting range	Control mode			Frame length
				CP/BCD	CL	PS	
[8] [1]	[0] [0]	Status display data deletion	1EA5	<input type="radio"/>	<input type="radio"/>	<input type="radio"/>	4

(2) Parameter (command [9] [4], [8] [5])

Command	Data No.	Description	Setting range	Control mode			Frame length
				CP/BCD	CL	PS	
[9] [4]	[0] [1] to [F] [F]	Writing each parameter Writes the values of the parameters in the parameter group specified with the command [8] [5] + data No. [0] [0]. Before writing the values, therefore, always specify the parameter group with the command [8] [5] + data No. [0] [0]. The decimal equivalent of the data No. (hexadecimal) value corresponds to the parameter No.	Depending on the parameter	<input type="radio"/>	<input type="radio"/>	<input type="radio"/>	12
[8] [5]	[0] [0]	Parameter group writing 0000: Basic setting parameters ([Pr. PA__]) 0001: Gain/filter parameters ([Pr. PB__]) 0002: Extension setting parameters ([Pr. PC__]) 0003: I/O setting parameters ([Pr. PD__]) 0004: Extension setting 2 parameters ([Pr. PE__]) 0005: Extension setting 3 parameters ([Pr. PF__]) 0009: Option setting parameters ([Pr. Po__]) 000B: Linear servo motor/DD motor setting parameters ([Pr. PL__]) (Note) 000C: Positioning control parameters ([Pr. PT__])	0000 to 000C	<input type="radio"/>	<input type="radio"/>	<input type="radio"/>	4

Note. This is not available with the MR-J4-03A6-RJ servo amplifier.

(3) External I/O signals (command [9] [2])

Command	Data No.	Description	Setting range	Control mode			Frame length
				CP/BCD	CL	PS	
[9] [2]	[6] [0] to [6] [2]	Communication input device signal	Refer to section 10.2.2.	<input type="radio"/>	<input type="radio"/>	<input type="radio"/>	8

(4) Alarm history (command [8] [2])

Command	Data No.	Description	Setting range	Control mode			Frame length
				CP/BCD	CL	PS	
[8] [2]	[2] [0]	Alarm history clear	1EA5	<input type="radio"/>	<input type="radio"/>	<input type="radio"/>	4

10. COMMUNICATION FUNCTION (MITSUBISHI GENERAL-PURPOSE AC SERVO PROTOCOL)

(5) Current alarm (command [8] [2])

Command	Data No.	Description	Setting range	Control mode			Frame length
				CP/BCD	CL	PS	
[8] [2]	[0] [0]	Alarm clear	1EA5	○	○	○	4

(6) I/O device prohibition (command [9] [0])

Command	Data No.	Description	Setting range	Control mode			Frame length
				CP/BCD	CL	PS	
[9] [0]	[0] [0]	Turns off the input device, external analog input signal, and pulse train input, except EM2, LSP and LSN, independently of the external on/off statuses.	1EA5	○	○	○	4
	[0] [3]	Prohibits all output devices (DO).	1EA5	○	○	○	
	[1] [0]	Cancels the prohibition of the input device, external analog input signal and pulse train input, except EM2, LSP and LSN.	1EA5	○	○	○	
	[1] [3]	Cancels the prohibition of the output device.	1EA5	○	○	○	

(7) Operation mode selection (command [8] [B])

Command	Data No.	Description	Setting range	Control mode			Frame length
				CP/BCD	CL	PS	
[8] [B]	[0] [0]	Selection of test operation mode 0000: Test operation mode cancel 0001: JOG operation 0002: Positioning operation 0004: Output signal (DO) forced output 0005: Single-step feed operation	0000 to 0002, 0004, 0005	○	○	○ (Note)	4

Note: "0005 (single-step feed operation)" is not available in the indexer method.

(8) Test operation mode data (command [9] [2], [A] [0])

Command	Data No.	Description	Setting range	Control mode			Frame length
				CP/BCD	CL	PS	
[9] [2]	[0] [0] to [0] [2]	Input signal for test operation	(Refer to section 14.5.7 of "MR-J4-_A_(-RJ) Servo Amplifier Instruction Manual".)	○	○	○	8
	[A] [0]	Forced output of signal pin	(Refer to section 14.5.9 of "MR-J4-_A_(-RJ) Servo Amplifier Instruction Manual".)	○	○	○	

10. COMMUNICATION FUNCTION (MITSUBISHI GENERAL-PURPOSE AC SERVO PROTOCOL)

Command	Data No.	Description	Setting range	Control mode			Frame length
				CP/BCD	CI	PS	
[A] [0]	[1] [0]	Writes the servo motor speed in the test operation mode (JOG operation and positioning operation).	0000 to 7FFF	<input type="radio"/>	<input type="radio"/>	<input type="radio"/>	4
	[1] [1]	Writes the acceleration/deceleration time constant in the test operation mode (JOG operation and positioning operation).	00000000 to 7FFFFFFF	<input type="radio"/>	<input type="radio"/>	<input type="radio"/>	8
	[2] [0]	Set the travel distance of the test operation mode (positioning operation).	00000000 to 7FFFFFFF	<input type="radio"/>	<input type="radio"/>	<input type="radio"/>	
	[2] [1]	Select the positioning direction of the test operation (positioning operation). <div style="display: flex; align-items: center;"> <div style="border: 1px solid black; padding: 2px; margin-right: 5px;">0</div> <div style="border: 1px solid black; padding: 2px; margin-right: 5px;">0</div> <div style="border: 1px solid black; padding: 2px; margin-right: 5px;"> </div> <div style="border: 1px solid black; padding: 2px; margin-right: 5px;"> </div> </div> <ul style="list-style-type: none"> 0: Forward rotation direction 1: Reverse rotation direction 0: Command pulse unit 1: Encoder pulse unit 	0000 to 0101	<input type="radio"/>	<input type="radio"/>	<input type="radio"/>	4
	[4] [0]	This is a start command of the test operation (positioning operation).	1EA5	<input type="radio"/>	<input type="radio"/>	<input type="radio"/>	
	[4] [1]	This is used to make a temporary stop during test operation (positioning operation). "□" in the data indicates a blank. STOP: Temporary stop GO□□: Restart for remaining distance CLR□: Remaining distance clear	STOP GO□□ CLR□	<input type="radio"/>	<input type="radio"/>	<input type="radio"/>	

(9) Point table setting data (command [C] [0], [C] [2], [C] [6], [C] [7], [C] [8], [C] [A], [C] [B])

Command	Data No.	Description	Setting range	Control mode			Frame length
				CP/BCD	CI	PS	
[C] [0]	[0] [0] to [F] [F]	Writing position data of each point table The decimal equivalent of the data No. value (hexadecimal) corresponds to the point table No.	-999999 to 999999	<input type="radio"/>	<input type="checkbox"/>	<input type="checkbox"/>	8
[C] [2]	[0] [0] to [F] [F]	Writing M code of each point table The decimal equivalent of the data No. value (hexadecimal) corresponds to the point table No.	0 to 99	<input type="radio"/>	<input type="checkbox"/>	<input type="checkbox"/>	
[C] [6]	[0] [0] to [F] [F]	Writing speed data of each point table The decimal equivalent of the data No. value (hexadecimal) corresponds to the point table No.	0 to permissible speed	<input type="radio"/>	<input type="checkbox"/>	<input type="checkbox"/>	
[C] [7]	[0] [0] to [F] [F]	Writing acceleration time constant of each point table The decimal equivalent of the data No. value (hexadecimal) corresponds to the point table No.	0 to 20000	<input type="radio"/>	<input type="checkbox"/>	<input type="checkbox"/>	
[C] [8]	[0] [0] to [F] [F]	Writing deceleration time constant of each point table The decimal equivalent of the data No. value (hexadecimal) corresponds to the point table No.	0 to 20000	<input type="radio"/>	<input type="checkbox"/>	<input type="checkbox"/>	
[C] [A]	[0] [0] to [F] [F]	Writing dwell of each point table The decimal equivalent of the data No. value (hexadecimal) corresponds to the point table No.	0 to 20000	<input type="radio"/>	<input type="checkbox"/>	<input type="checkbox"/>	
[C] [B]	[0] [0] to [F] [F]	Writing auxiliary function of each point table The decimal equivalent of the data No. value (hexadecimal) corresponds to the point table No.	0 to 3, 8 to 11	<input type="radio"/>	<input type="checkbox"/>	<input type="checkbox"/>	

10. COMMUNICATION FUNCTION (MITSUBISHI GENERAL-PURPOSE AC SERVO PROTOCOL)

(10) General purpose register (Rx) value (command [B] [9])

Command	Data No.	Description	Setting range	Control mode			Frame length
				CP/BCD	CL	PS	
[B] [9]	[0] [1]	Writing general purpose register (R1) value	Depends on instructions to use. Refer to section 5.2.2.	○	○	○	8
	[0] [2]	Writing general purpose register (R2) value		○	○	○	
	[0] [3]	Writing general purpose register (R3) value		○	○	○	
	[0] [4]	Writing general purpose register (R4) value		○	○	○	

(11) General purpose register (Dx) value (command [B] [A])

Command	Data No.	Description	Setting range	Control mode			Frame length
				CP/BCD	CL	PS	
[B] [A]	[0] [1]	Writing general purpose register (D1) value	Depends on instructions to use. Refer to section 5.2.2.	○	○	○	8
	[0] [2]	Writing general purpose register (D2) value		○	○	○	
	[0] [3]	Writing general purpose register (D3) value		○	○	○	
	[0] [4]	Writing general purpose register (D4) value		○	○	○	

10. COMMUNICATION FUNCTION (MITSUBISHI GENERAL-PURPOSE AC SERVO PROTOCOL)

10.2 Detailed explanations of commands

10.2.1 External I/O signal status (DIO diagnosis)

(1) Reading input device status

The current input device status can be read.

(a) Transmission

Transmit command [1] [2] + data No. [0] [0] to [0] [3].

Command	Data No.
[1] [2]	[0] [0] to [0] [3]

(b) Return

The slave station returns the status of the input devices.

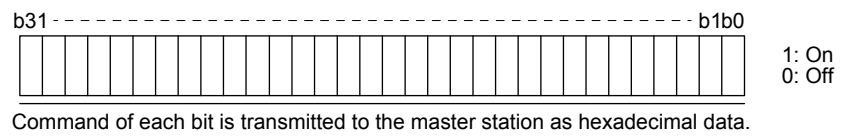

Bit	Symbol			
	Data No. [0] [0]	Data No. [0] [1]	Data No. [0] [2]	Data No. [0] [3]
0	SON		MD0	POS00
1	LSP	ABSM	MD1	POS01
2	LSN	ABSR		POS02
3	TL		TCH	POS03
4	TL1		TP0	POS10
5	PC		TP1	POS11
6	RES		OVR	POS12
7	CR			POS13
8	SP1		STAB	POS20
9	SP2		DOG/SIG	POS21
10	SP3		SPD1	POS22
11	ST1/RS2		SPD2	POS23
12	ST2/RS1		SPD3	POSP
13	CMX1		SPD4	POSN
14	CMX2			STRB
15	LOP			
16		MSD	LPS	
17		PI1	RT	
18	EM2/EM1	PI2	RTCDP	
19		PI3		
20	STAB2	CAMC	OV0	
21		CI0	OV1	
22		CI1	OV2	
23		CI2	OV3	
24	TSTP	CI3	D10	
25		CLTC	D11	
26		CPCD	D12	
27	CDP		D13	
28	CLD		D14	
29	MECR (Note)		D15	
30			D16	
31			D17	

Note. This is not available with the MR-J4-03A6-RJ servo amplifier.

10. COMMUNICATION FUNCTION (MITSUBISHI GENERAL-PURPOSE AC SERVO PROTOCOL)

(2) Reading external input pin status

Reads the on/off statuses of the external input pins.

(a) Transmission

Transmit command [1] [2] + data No. [4] [0], [4] [1].

Command	Data No.
[1] [2]	[4] [0], [4] [1]

(b) Return

The on/off statuses of the input pins are returned.

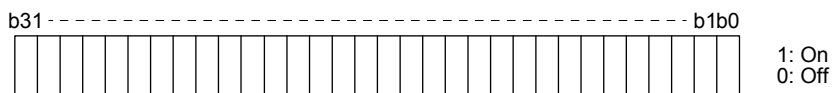

Command of each bit is transmitted to the master station as hexadecimal data.

Bit	CN1 connector pin	CN10 connector pin	Bit	CN1 connector pin	CN10 connector pin
0	43	1	16		19
1	44	2	17		20
2	42	3	18		21
3	15	4	19		26
4	19	5	20		27
5	41	6	21		28
6	16	7	22		29
7	17	8	23		30
8	18	9	24		31
9	45	10	25		32
10	10 (Note)	11	26		33
11	35 (Note)	12	27		34
12		15	28		35
13		16	29		36
14		17	30		
15		18	31		

Note. When the pulse train input is selected with [Pr. PD44] or [Pr. PD46], this bit will continuously be "0" (off).

10. COMMUNICATION FUNCTION (MITSUBISHI GENERAL-PURPOSE AC SERVO PROTOCOL)

(3) Reading the status of input devices switched on with communication

Reads the on/off statuses of the input devices switched on with communication.

(a) Transmission

Transmit command [1] [2] + data No. [6] [0] to [6] [3].

Command	Data No.
[1] [2]	[6] [0] to [6] [3]

(b) Return

The slave station returns the status of the input devices.

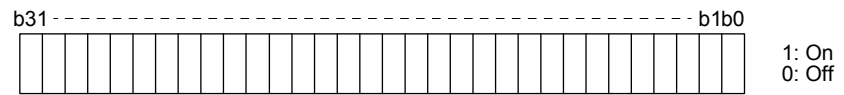

Command of each bit is transmitted to the master station as hexadecimal data.

Bit	Symbol			
	Data No. [6] [0]	Data No. [6] [1]	Data No. [6] [2]	Data No. [6] [3]
0	SON		MD0	POS00
1	LSP	ABSM	MD1	POS01
2	LSN	ABSR		POS02
3	TL		TCH	POS03
4	TL1		TP0	POS10
5	PC		TP1	POS11
6	RES		OVR	POS12
7	CR			POS13
8	SP1		STAB	POS20
9	SP2		DOG/SIG	POS21
10	SP3		SPD1	POS22
11	ST1/RS2		SPD2	POS23
12	ST2/RS1		SPD3	POSP
13	CMX1		SPD4	POSN
14	CMX2			STRB
15	LOP			
16		MSD	LPS	
17		PI1	RT	
18	EM2/EM1	PI2	RTCDP	
19		PI3		
20	STAB2	CAMC	OV0	
21		CI0	OV1	
22		CI1	OV2	
23		CI2	OV3	
24	TSTP	CI3	D10	
25		CLTC	D11	
26		CPCD	D12	
27	CDP		D13	
28	CLD		D14	
29	MECR (Note)		D15	
30			D16	
31			D17	

Note. This is not available with the MR-J4-03A6-RJ servo amplifier.

10. COMMUNICATION FUNCTION (MITSUBISHI GENERAL-PURPOSE AC SERVO PROTOCOL)

(4) Reading external output pin status

Reads the on/off statuses of the external output pins.

(a) Transmission

Transmit command [1] [2] + data No. [C] [0], [C] [1].

Command	Data No.
[1] [2]	[C] [0], [C] [1]

(b) Return

The slave station returns the status of the output devices.

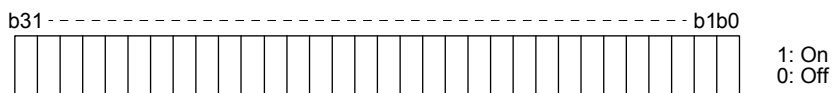

Command of each bit is transmitted to the master station as hexadecimal data.

Bit	CN1 connector pin	CN10 connector pin	Bit	CN1 connector pin	CN10 connector pin
0	49	22	16		
1	24	23	17		
2	23	24	18		
3	25	25	19		
4	22	38	20		
5	48	39	21		
6	33	40	22		
7	13 (Note)	41	23		
8	14 (Note)	42	24		
9		43	25		
10		44	26		
11		45	27		
12		46	28		
13		47	29		
14		48	30		
15		49	31		

Note. This is not available with the MR-J4-03A6-RJ servo amplifier.

10. COMMUNICATION FUNCTION (MITSUBISHI GENERAL-PURPOSE AC SERVO PROTOCOL)

(5) Reading output device status

Reads the on/off statuses of the output devices.

(a) Transmission

Transmit command [1] [2] + data No. [8] [0] to [8] [3].

Command	Data No.
[1] [2]	[8] [0] to [8] [3]

(b) Return

The slave station returns the status of the input/output devices.

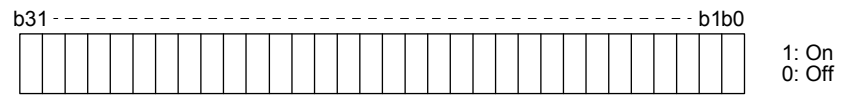

Command of each bit is transmitted to the master station as hexadecimal data.

Bit	Symbol			
	Data No. [8] [0]	Data No. [8] [1]	Data No. [8] [2]	Data No. [8] [3]
0	RD			MCD00
1	SA			MCD01
2	ZSP			MCD02
3	TLC		CPO	MCD03
4	VLC		ZP	MCD10
5	INP		POT	MCD11
6			PUS	MCD12
7	WNG		MEND	MCD13
8	ALM			ACD0
9	OP			ACD1
10	MBR			ACD2
11	DB (Note)			ACD3
12	ALCD0		PED	PRQ0
13	ALCD1			PRQ1
14	ALCD2			
15	BWNG			
16				
17			ALMWNG	
18			BW9F	
19		MSDH		
20		MSDL		
21		SOUT		
22		OUT1		
23		OUT2		
24		OUT3	PT0/PS0	
25	CDPS	CAMS	PT1/PS1	
26	CLDS (Note)	CLTS	PT2/PS2	
27	ABSV	CLTSM	PT3/PS3	
28		CLTS	PT4/PS4	
29			PT5/PS5	
30			PT6/PS6	
31	MTTR (Note)		PT7/PS7	

Note. This is not available with the MR-J4-03A6-RJ servo amplifier.

10. COMMUNICATION FUNCTION (MITSUBISHI GENERAL-PURPOSE AC SERVO PROTOCOL)

10.2.2 Input device on/off

POINT	<p>● The on/off statuses of all devices in the servo amplifier are the status of the data received at last. Therefore, when there is a device which must be kept on, transmit data which turns the device on every time.</p>
--------------	--

Each input device can be switched on/off. However, when the device to be switched off is in the external input signal, also switch off the input signal.

Transmit command [9] [2] + data No. [6] [0] to [6] [3].

Command	Data No.	Setting data
[9] [2]	[6] [0] to [6] [3]	See below.

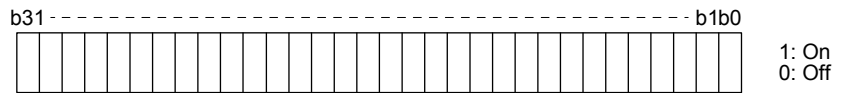

Command of each bit is transmitted to the master station as hexadecimal data.

Bit	Symbol			
	Data No. [6] [0]	Data No. [6] [1]	Data No. [6] [2]	Data No. [6] [3]
0	SON		MD0	POS00
1	LSP	ABSM	MD1	POS01
2	LSN	ABSR		POS02
3	TL		TCH	POS03
4	TL1		TP0	POS10
5	PC		TP1	POS11
6	RES		OVR	POS12
7	CR			POS13
8	SP1		STAB	POS20
9	SP2		DOG/SIG	POS21
10	SP3		SPD1	POS22
11	ST1/RS2		SPD2	POS23
12	ST2/RS1		SPD3	POSP
13	CMX1		SPD4	POSN
14	CMX2			STRB
15	LOP			
16		MSD	LPS	
17		PI1	RT	
18	EM2/EM1	PI2	RTCDP	
19		PI3		
20	STAB2	CAMC	OV0	
21		CI0	OV1	
22		CI1	OV2	
23		CI2	OV3	
24	TSTP	CI3	DI0	
25		CLTC	DI1	
26		CPCD	DI2	
27	CDP		DI3	
28	CLD		DI4	
29	MECR (Note)		DI5	
30			DI6	
31			DI7	

Note. This is not available with the MR-J4-03A6-RJ servo amplifier.

10. COMMUNICATION FUNCTION (MITSUBISHI GENERAL-PURPOSE AC SERVO PROTOCOL)

10.2.3 Input device on/off (for test operation)

Each input devices can be turned on/off for test operation. However, when the device to be switched off is in the external input signal, also switch off the input signal.

Transmit command [9] [2] + data No. [0] [0] to [0] [3].

Command	Data No.	Setting data
[9] [2]	[0] [0] to [0] [3]	See below.

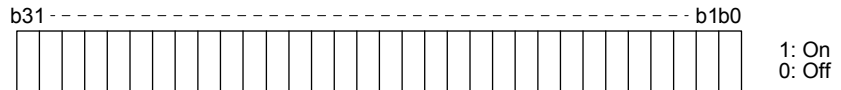

Command of each bit is transmitted to the master station as hexadecimal data.

Bit	Symbol			
	Data No. [0] [0]	Data No. [0] [1]	Data No. [0] [2]	Data No. [0] [3]
0	SON		MD0	POS00
1	LSP	ABSM	MD1	POS01
2	LSN	ABSR		POS02
3	TL		TCH	POS03
4	TL1		TP0	POS10
5	PC		TP1	POS11
6	RES		OVR	POS12
7	CR			POS13
8	SP1		STAB	POS20
9	SP2		DOG/SIG	POS21
10	SP3		SPD1	POS22
11	ST1/RS2		SPD2	POS23
12	ST2/RS1		SPD3	POSP
13	CMX1		SPD4	POSN
14	CMX2			STRB
15	LOP			
16		MSD	LPS	
17		PI1	RT	
18	EM2/EM1	PI2	RTCDP	
19		PI3		
20	STAB2	CAMC	OV0	
21		CI0	OV1	
22		CI1	OV2	
23		CI2	OV3	
24	TSTP	CI3	DI0	
25		CLTC	DI1	
26		CPCD	DI2	
27	CDP		DI3	
28	CLD		DI4	
29	MECR (Note)		DI5	
30			DI6	
31			DI7	

Note. This is not available with the MR-J4-03A6-RJ servo amplifier.

10.2.4 Test operation mode

POINT
<ul style="list-style-type: none"> ● The test operation mode is used to check operation. Do not use it for actual operation. ● If communication stops for longer than 0.5 s during test operation, the servo amplifier decelerates to a stop, resulting in servo-lock. To prevent this, keep the communication all the time by checking the status display, etc. ● Even during operation, you can switch the servo amplifier to the test operation mode. In this case, switching to the test operation mode will shut off the base circuit to coast the motor.

(1) How to prepare and cancel the test operation mode

(a) Preparing the test operation mode

Set the test operation mode type with the following procedure.

1) Selection of test operation mode

Transmit the command [8] [B] + data No. [0] [0] + data to select the test operation mode.

Command	Data No.	Transmission data	Selection of test operation mode
[8] [B]	[0] [0]	0004	Output signal (DO) forced output (Note)
		0005	Single-step feed

Note. Refer to section 10.2.5 for the output signal (DO) forced output.

2) Check of test operation mode

Read the test operation mode set for the slave station, and check that it is set correctly.

a) Transmission

Transmit command [0] [0] + data No. [1] [2].

Command	Data No.
[0] [0]	[1] [2]

b) Return

The slave station returns the preset operation mode.

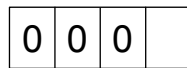

- Reading test operation mode
- 0: Normal mode (not test operation mode)
 - 1: JOG operation
 - 2: Positioning operation
 - 3: Motor-less operation
 - 4: Output signal (DO) forced output
 - 5: Single-step feed

(b) Cancel of test operation mode

To stop the test operation mode, transmit the command [8] [B] + data No. [0] [0] + data. Before switching from the test operation mode to the normal operation mode, turn off the servo amplifier once.

Command	Data No.	Transmission data	Selection of test operation mode
[8] [B]	[0] [0]	0000	Test operation mode canceled

(2) Single-step feed

Set each value of target point tables for the single-step feed before executing single-step feed. Transmit command and data No. to execute single-step feed.

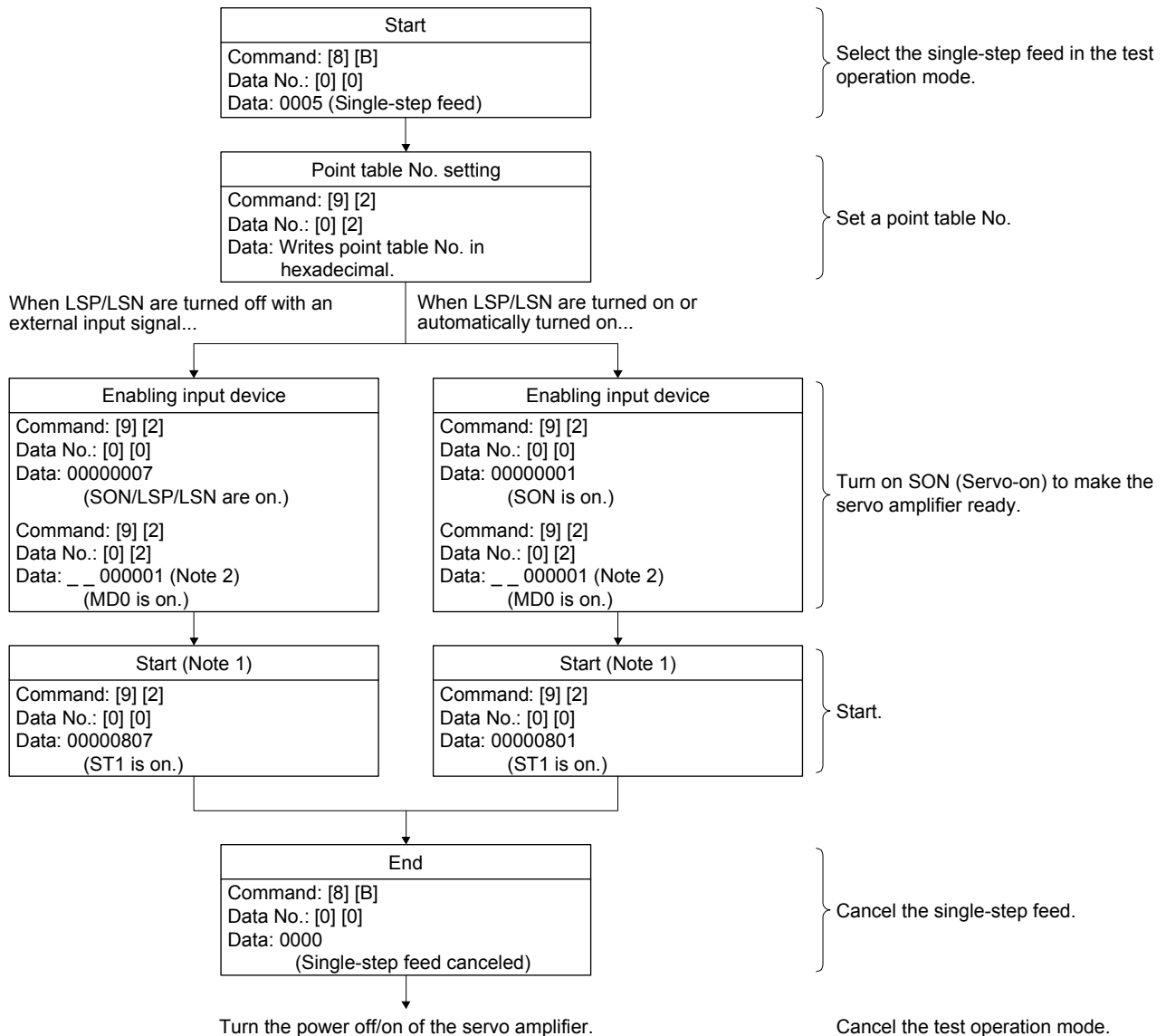

Note 1. After checking ZP (Home position return completion), start it. See the 4 bit of the read data with the command [1] [2] and data No. [8] [2].
 Note 2. A point table No. in hexadecimal will be entered to "__".

10. COMMUNICATION FUNCTION (MITSUBISHI GENERAL-PURPOSE AC SERVO PROTOCOL)

10.2.5 Output signal pin on/off (output signal (DO) forced output)

In the test operation mode, the output signal pins can be turned on/off regardless of the servo status. Disable the external input signals in advance with command [9] [0].

(1) Selecting the output signal (DO) forced output of the test operation mode

Transmit command + [8] [B] + data No. [0] [0] + data "0004" to select the output signal (DO) forced output.

0	0	0	4
---	---	---	---

Selection of test operation mode
4: Output signal (DO) forced output

(2) External output signal on/off

Transmit the following communication commands.

Command	Data No.	Setting data
[9] [2]	[A] [0], [A] [1]	See below.

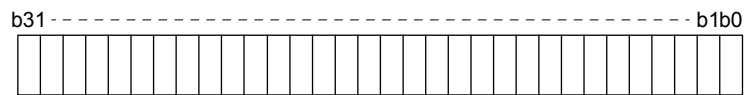

1: On
0: Off

Command of each bit is transmitted to the master station as hexadecimal data.

Bit	CN1 connector pin	CN10 connector pin	Bit	CN1 connector pin	CN10 connector pin
0	49	22	16		
1	24	23	17		
2	23	24	18		
3	25	25	19		
4	22	38	20		
5	48	39	21		
6	33	40	22		
7	13 (Note)	41	23		
8	14 (Note)	42	24		
9		43	25		
10		44	26		
11		45	27		
12		46	28		
13		47	29		
14		48	30		
15		49	31		

Note. This is not available with the MR-J4-03A6-RJ servo amplifier.

(3) Output signal (DO) forced output

To stop the output signal (DO) forced output, transmit command [8] [B] + data No. [0] [0] + data. Before switching from the test operation mode to the normal operation mode, turn off the servo amplifier once.

Command	Data No.	Transmission data	Selection of test operation mode
[8] [B]	[0] [0]	0000	Test operation mode canceled

10.2.6 Point table

(1) Reading data

(a) Position data

Reads position data of point tables.

1) Transmission

Transmits the command [4] [0] + the data No. [0] [1] to [F] [F] corresponding to the point tables to read. Refer to section 10.1.1.

2) Return

The slave station returns the position data of point table requested.

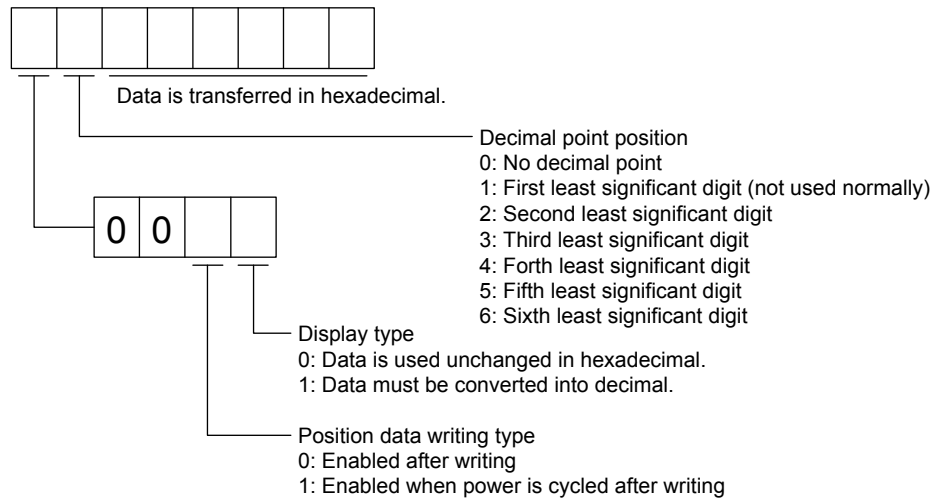

(b) Speed data

Reads speed data of point tables.

1) Transmission

Transmits the command [5] [0] + the data No. [0] [1] to [F] [F] corresponding to the point tables to read. Refer to section 10.1.1.

2) Return

The slave station returns the speed data of point table requested.

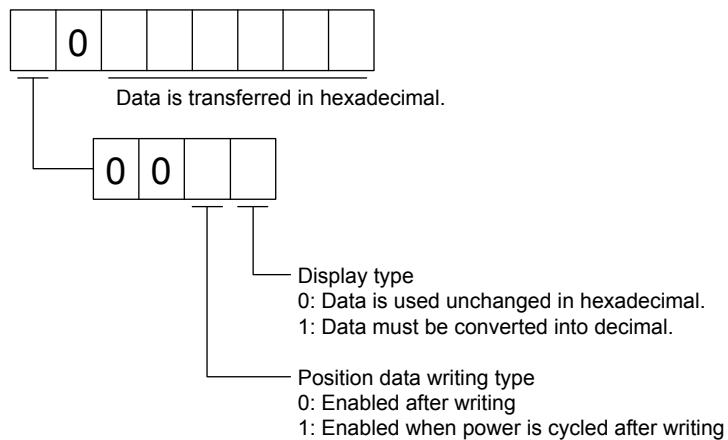

10. COMMUNICATION FUNCTION (MITSUBISHI GENERAL-PURPOSE AC SERVO PROTOCOL)

(c) Acceleration time constant

Reads acceleration time constant of point tables.

1) Transmission

Transmits the command [5] [4] + the data No. [0] [1] to [F] [F] corresponding to the point tables to read. Refer to section 10.1.1.

2) Return

The slave station returns the acceleration time constant of point table requested.

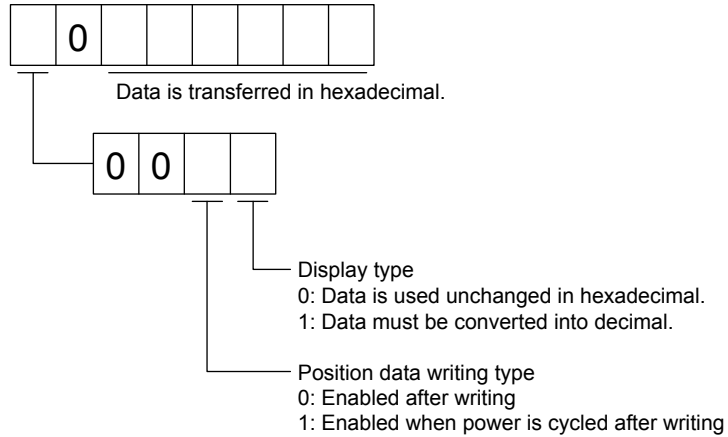

(d) Deceleration time constant

Reads deceleration time constant of point tables.

1) Transmission

Transmits the command [5] [8] + the data No. [0] [1] to [F] [F] corresponding to the point tables to read. Refer to section 10.1.1.

2) Return

The slave station returns the deceleration time constant of point table requested.

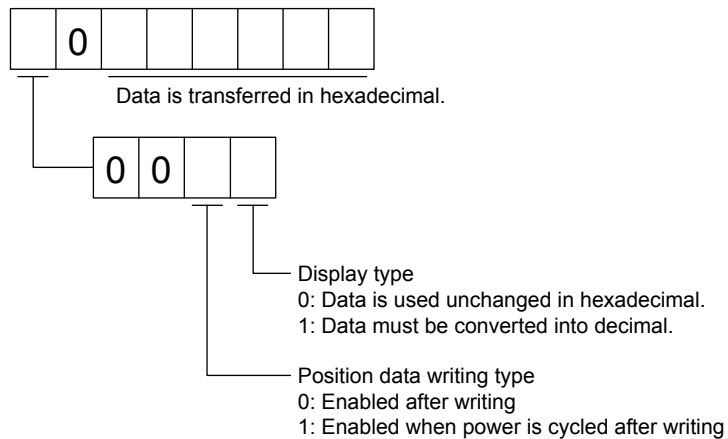

(e) Dwell

Reads dwell of point tables.

1) Transmission

Transmits the command [6] [0] + the data No. [0] [1] to [F] [F] corresponding to the point tables to read. Refer to section 10.1.1.

2) Return

The slave station returns the dwell of point table requested.

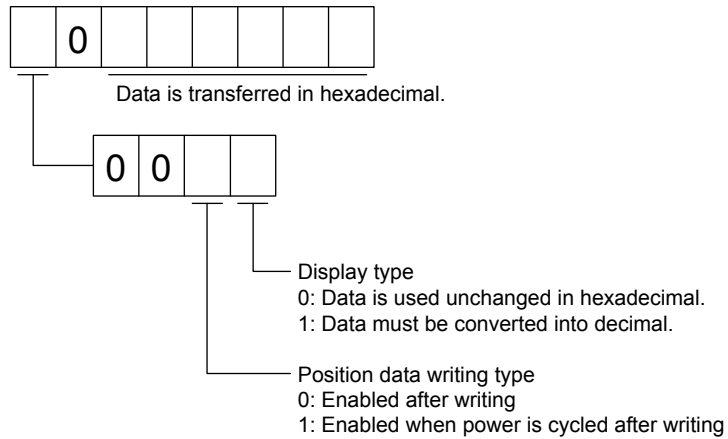

(f) Auxiliary function

Reads auxiliary function of point tables.

1) Transmission

Transmits the command [6] [4] + the data No. [0] [1] to [F] [F] corresponding to the point tables to read. Refer to section 10.1.1.

2) Return

The slave station returns the auxiliary function of point table requested.

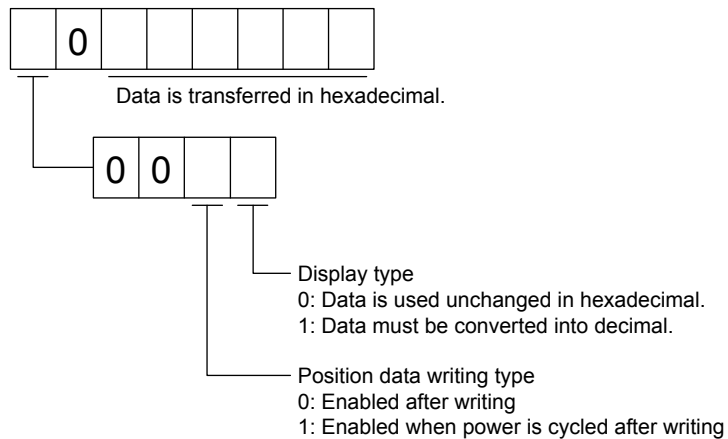

10. COMMUNICATION FUNCTION (MITSUBISHI GENERAL-PURPOSE AC SERVO PROTOCOL)

(g) M code

Reads M code of point tables.

1) Transmission

Transmits the command [4] [5] + the data No. [0] [1] to [F] [F] corresponding to the point tables to read. Refer to section 10.1.1.

2) Return

The slave station returns the M code of point table requested.

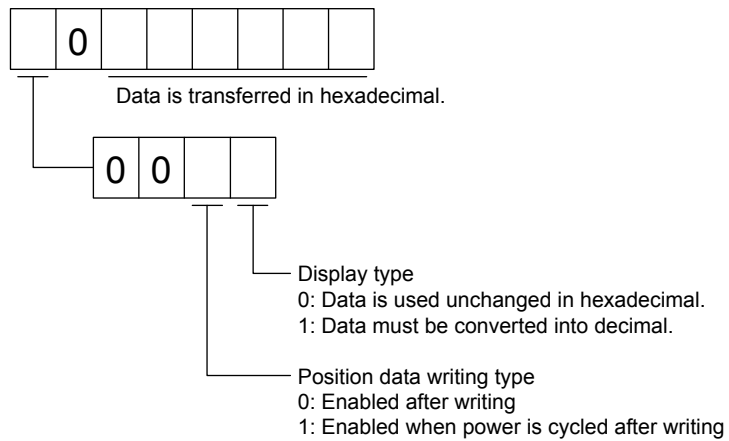

(2) Writing data

 CAUTION	<p>● If setting values need to be changed with a high frequency (i.e. once or more per one hour), write the setting values to the RAM, not to the EEPROM. The EEPROM has a limitation in the number of write times and exceeding this limitation causes the servo amplifier to malfunction. Note that the number of write times to the EEPROM is limited to approximately 100,000.</p>
--	--

(a) Position data

Writes position data of point tables.

Transmits the command [C] [0] + the data No. [0] [1] to [F] [F] corresponding to the point tables to write + data. Refer to section 10.1.1.

Command	Data No.	Data
[C] [0]	[0] [1] to [F] [F]	Refer to the following diagram.

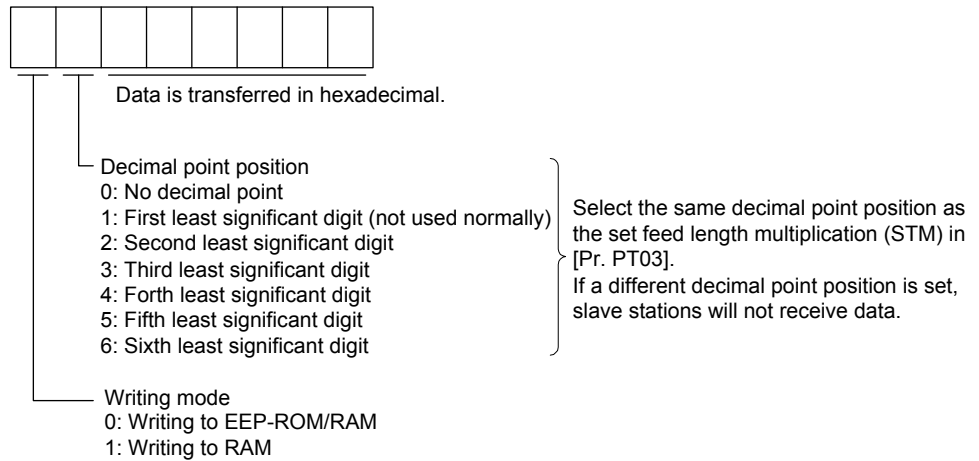

When the position data is changed frequently using communication, set "1" to the mode to change only the RAM data in the servo amplifier.

When changing data once or more within an hour, do not write it to the EEPROM.

(b) Speed data

Writes speed data of point tables.

Transmits the command [C] [6] + the data No. [0] [1] to [F] [F] corresponding to the point tables to write + data. Refer to section 10.1.1.

Command	Data No.	Data
[C] [6]	[0] [1] to [F] [F]	Refer to the following diagram.

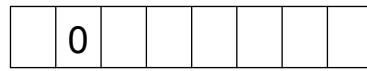

Hexadecimal

Writing mode

0: Writing to EEP-ROM/RAM

1: Writing to RAM

When the speed data is changed frequently using communication, set "1" to the mode to change only the RAM data in the servo amplifier.

When changing data once or more within an hour, do not write it to the EEP-ROM.

(c) Acceleration time constant

Writes acceleration time constant of point tables.

Transmits the command [C] [7] + the data No. [0] [1] to [F] [F] corresponding to the point tables to write + data. Refer to section 10.1.1.

Command	Data No.	Data
[C] [7]	[0] [1] to [F] [F]	Refer to the following diagram.



Hexadecimal

Writing mode

0: Writing to EEP-ROM/RAM

1: Writing to RAM

When the acceleration time constant is changed frequently using communication, set "1" to the mode to change only the RAM data in the servo amplifier.

When changing data once or more within an hour, do not write it to the EEP-ROM.

(d) Deceleration time constant

Writes deceleration time constant of point tables.

Transmits the command [C] [8] + the data No. [0] [1] to [F] [F] corresponding to the point tables to write + data. Refer to section 10.1.1.

Command	Data No.	Data
[C] [8]	[0] [1] to [F] [F]	Refer to the following diagram.



Writing mode
 0: Writing to EEP-ROM/RAM
 1: Writing to RAM

When the deceleration time constant is changed frequently using communication, set "1" to the mode to change only the RAM data in the servo amplifier.

When changing data once or more within an hour, do not write it to the EEP-ROM.

(e) Dwell

Writes dwell of point tables.

Transmits the command [C] [A] + the data No. [0] [1] to [F] [F] corresponding to the point tables to write + data. Refer to section 10.1.1.

Command	Data No.	Data
[C] [A]	[0] [1] to [F] [F]	Refer to the following diagram.



Writing mode
 0: Writing to EEP-ROM/RAM
 1: Writing to RAM

When the dwell is changed frequently using communication, set "1" to the mode to change only the RAM data in the servo amplifier.

When changing data once or more within an hour, do not write it to the EEP-ROM.

(f) Auxiliary function

Writes auxiliary function of point tables.

Transmits the command [C] [B] + the data No. [0] [1] to [F] [F] corresponding to the point tables to write + data. Refer to section 10.1.1.

Command	Data No.	Data
[C] [B]	[0] [1] to [F] [F]	Refer to the following diagram.



Writing mode
 0: Writing to EEP-ROM/RAM
 1: Writing to RAM

When the auxiliary function is changed frequently using communication, set "1" to the mode to change only the RAM data in the servo amplifier.

When changing data once or more within an hour, do not write it to the EEP-ROM.

(g) M code

Writes M code of point tables.

Transmits the command [C] [2] + the data No. [0] [1] to [F] [F] corresponding to the point tables to write + data. Refer to section 10.1.1.

Command	Data No.	Data
[C] [2]	[0] [1] to [F] [F]	Refer to the following diagram.



Writing mode
 0: Writing to EEP-ROM/RAM
 1: Writing to RAM

When the M code is changed frequently using communication, set "1" to the mode to change only the RAM data in the servo amplifier.

When changing data once or more within an hour, do not write it to the EEP-ROM.

10. COMMUNICATION FUNCTION (MITSUBISHI GENERAL-PURPOSE AC SERVO PROTOCOL)

10.3 Settings equivalent to previous models

You can change the status monitor display and DIO function map to communication commands of MR-J3-T or MR-J2S-CP with "RS-422 communication - Previous model equivalent selection" in [Pr. PT01].

10.3.1 Relevant matters to monitor information

You can use the commands and data Nos. for previous models (MR-J3-T/MR-J2S-CP) as they are.

Command	Data No.	[Pr. PT01]: "0 ___" (MR-J4 standard)	[Pr. PT01]: "1 ___" (equivalent to MR-J3-T)	[Pr. PT01]: "2 ___" (equivalent to MR-J2S-CP)	[Pr. PT01]: "3 ___" (equivalent to MR-J2S-CL)
[0] [1] [0] [E]	[0] [0]/[8] [0]	Cumulative feedback pulses	Current position	Current position	Current position
[3] [5] [3] [E]	[0] [1]/[8] [1]	Servo motor speed/ Linear servo motor speed	Command position	Command position	Command position
[8] [1]	[0] [2]/[8] [2]	Droop pulses	Command remaining distance	Command remaining distance	Command remaining distance
	[0] [3]/[8] [3]	Cumulative command pulses	Point table No.	Point table No.	Program No.
	[0] [4]/[8] [4]	Command pulse frequency	Cumulative feedback pulses	Cumulative feedback pulses	Step No.
	[0] [5]/[8] [5]	Analog speed command voltage/ Analog speed limit voltage	Servo motor speed/ Linear servo motor speed	Servo motor speed/ Linear servo motor speed	Cumulative feedback pulses
	[0] [6]/[8] [6]	Analog torque limit voltage/ Analog torque command voltage	Droop pulses	Droop pulses	Servo motor speed
	[0] [7]/[8] [7]	Regenerative load ratio	Analog override voltage	Override level	Droop pulses
	[0] [8]/[8] [8]	Effective load ratio	Override level	Analog torque limit voltage	Override level
	[0] [9]/[8] [9]	Peak load ratio	Analog torque limit voltage	Regenerative load ratio	Analog torque limit voltage
	[0] [A]/[8] [A]	Instantaneous torque	Regenerative load ratio	Effective load ratio	Regenerative load ratio
	[0] [B]/[8] [B]	Position within one-revolution	Effective load ratio	Peak load ratio	Effective load ratio
	[0] [C]/[8] [C]	ABS counter	Peak load ratio	Instantaneous torque	Peak load ratio
	[0] [D]/[8] [D]	Load to motor inertia ratio	Instantaneous torque	Position within one-revolution	Instantaneous torque
	[0] [E]/[8] [E]	Bus voltage	Position within one-revolution	ABS counter	Position within one-revolution
	[0] [F]/[8] [F] (Note)	Load-side encoder cumulative feedback pulses	ABS counter	Load to motor inertia ratio	ABS counter
	[1] [0]/[9] [0] (Note)	Load-side encoder droop pulses	Load to motor inertia ratio	Bus voltage	Load to motor inertia ratio
	[1] [1]/[9] [1] (Note)	Load-side encoder information 1	Bus voltage		Bus voltage
	[1] [2]/[9] [2] (Note)	Load-side encoder information 2			
	[1] [3]/[9] [3]				
	[1] [4]/[9] [4]				
	[1] [5]/[9] [5]				
	[1] [6]/[9] [6] (Note)	Temperature of servo motor thermistor			

10. COMMUNICATION FUNCTION (MITSUBISHI GENERAL-PURPOSE AC SERVO PROTOCOL)

Command	Data No.	[Pr. PT01]: "0 _ _ _" (MR-J4 standard)	[Pr. PT01]: "1 _ _ _" (equivalent to MR-J3-T)	[Pr. PT01]: "2 _ _ _" (equivalent to MR-J2S-CP)	[Pr. PT01]: "3 _ _ _" (equivalent to MR-J2S-CL)
[0] [1] [0] [E] [3] [5] [3] [E] [8] [1]	[1] [7]/[9] [7] (Note)	Cumulative feedback pulses (servo motor-side unit)			
	[1] [8]/[9] [8] (Note)	Electrical angle			
	[1] [9]/[9] [9]				
	[1] [A]/[9] [A]				
	[1] [B]/[9] [B]				
	[1] [C]/[9] [C]				
	[1] [D]/[9] [D]				
	[1] [E]/[9] [E] (Note)	Servo motor-side/load-side position deviation			
	[1] [F]/[9] [F] (Note)	Servo motor-side/load-side speed deviation			
	[2] [0]/[A] [0]	Encoder inside temperature			
	[2] [1]/[A] [1]	Settling time			
	[2] [2]/[A] [2]	Oscillation detection frequency			
	[2] [3]/[A] [3]	Number of tough drive operations			
	[2] [4]/[A] [4]				
	[2] [5]/[A] [5]				
	[2] [6]/[A] [6]				
	[2] [7]/[A] [7]				
	[2] [8]/[A] [8]	Unit power consumption			
	[2] [9]/[A] [9]	Unit total power consumption			
	[2] [A]/[A] [A]	Current position			
	[2] [B]/[A] [B]	Command position			
	[2] [C]/[A] [C]	Command remaining distance			
	[2] [D]/[A] [D]	Point table No./ Program No./ Station position No.			
	[2] [E]/[A] [E]	Step No.			
	[2] [F]/[A] [F]	Analog override voltage			
	[3] [0]/[B] [0]	Override level			
	[3] [1]/[B] [1]				
	[3] [3]/[B] [3]	Cam axis one cycle current value			
	[3] [4]/[B] [4]	Cam standard position			
	[3] [5]/[B] [5]	Cam axis feed current value			
	[3] [6]/[B] [6]	Cam No. in execution			
	[3] [7]/[B] [7]	Cam stroke amount in execution			
	[3] [8]/[B] [8]	Main axis current value			
	[3] [9]/[B] [9]	Main axis one cycle current value			

Note. This is not available with the MR-J4-03A6-RJ servo amplifier.

10. COMMUNICATION FUNCTION (MITSUBISHI GENERAL-PURPOSE AC SERVO PROTOCOL)

10.3.2 Relevant matters to input/output

(1) Input signal (command [1] [2], [9] [2])

(a) "0 _ _ _" (MR-J4 standard) is set to [Pr. PT01]

Bit	Symbol			
	Data No. [0] [0], [6] [0]	Data No. [0] [1], [6] [1]	Data No. [0] [2], [6] [2]	Data No. [0] [3], [6] [3]
0	SON		MD0	POS00
1	LSP	ABSM	MD1	POS01
2	LSN	ABSR		POS02
3	TL		TCH	POS03
4	TL1		TP0	POS10
5	PC		TP1	POS11
6	RES		OVR	POS12
7	CR			POS13
8	SP1			POS20
9	SP2		DOG/SIG	POS21
10	SP3		SPD1	POS22
11	ST1/RS2		SPD2	POS23
12	ST2/RS1		SPD3	POSP
13	CMX1		SPD4	POSN
14	CMX2			STRB
15	LOP			
16		MSD	LPS	
17		PI1	RT	
18	EM2/EM1	PI2	RTCDP	
19		PI3		
20	STAB2	CAMC	OV0	
21		CI0	OV1	
22		CI1	OV2	
23		CI2	OV3	
24	TSTP	CI3	DI0	
25		CLTC	DI1	
26		CPCD	DI2	
27	CDP		DI3	
28	CLD		DI4	
29	MECR (Note)		DI5	
30			DI6	
31			DI7	

Note. This is not available with the MR-J4-03A6-RJ servo amplifier.

10. COMMUNICATION FUNCTION (MITSUBISHI GENERAL-PURPOSE AC SERVO PROTOCOL)

(b) "1 ___" (equivalent to MR-J3-T) is set to [Pr. PT01]

Bit	Symbol		
	Data No. [0] [0], [6] [0]	Data No. [0] [1], [6] [1]	Data No. [0] [2], [6] [2]
0	SON		POS00
1	LSP		POS01
2	LSN		POS02
3	TL		POS03
4	TL1		POS10
5	PC		POS11
6	RES		POS12
7	CR		POS13
8			POS20
9			POS21
10			POS22
11	ST1		POS23
12	ST2		POSP
13			POSN
14			STRB
15			
16			
17	MD0		
18	DOG		
19			
20		SPD1	
21		SPD2	
22		SPD3	
23	OVR	SPD4	
24	TSTP	DI0	
25	TP0	DI1	
26	TP1	DI2	
27	CDP	DI3	
28		DI4	
29		DI5	
30		DI6	
31		DI7	

(c) "2 ___" (equivalent to MR-J2S-CP) is set to [Pr. PT01]

Bit	Symbol		Bit	Symbol	
	Data No. [0] [0], [6] [0]			Data No. [0] [0], [6] [0]	
0	SON		16	EM2/EM1	
1	LSP		17	MD0	
2	LSN		18	DOG	
3	TL		19	DI0	
4	TL1		20	DI1	
5	PC		21	DI2	
6	RES		22	DI3	
7			23	OVR	
8			24	TSTP	
9			25	TP0	
10			26	TP1	
11	ST1		27	CDP	
12	ST2		28		
13			29	DI4	
14			30	TCH	
15			31		

10. COMMUNICATION FUNCTION (MITSUBISHI GENERAL-PURPOSE AC SERVO PROTOCOL)

(d) "3 ___" (equivalent to MR-J2S-CL) is set to [Pr. PT01]

Bit	Symbol	Bit	Symbol
	Data No. [0] [0], [6] [0]		Data No. [0] [0], [6] [0]
0	SON	16	EM2/EM1
1	LSP	17	MD0
2	LSN	18	DOG
3	TL	19	DI0
4	TL1	20	DI1
5	PC	21	DI2
6	RES	22	DI3
7		23	OVR
8		24	TSTP
9		25	TP0
10	LPS	26	TP1
11	ST1	27	CDP
12	ST2	28	
13		29	PI1
14		30	PI2
15		31	PI3

(2) Output signal (command [1] [2])

(a) "0 ___" (MR-J4 standard) is set to [Pr. PT01]

Bit	Symbol			
	Data No. [0] [0], [8] [0]	Data No. [0] [1], [8] [1]	Data No. [0] [2], [8] [2]	Data No. [0] [3], [8] [3]
0	RD			MCD00
1	SA			MCD01
2	ZSP			MCD02
3	TLC		CPO	MCD03
4	VLC		ZP	MCD10
5	INP		POT	MCD11
6			PUS	MCD12
7	WNG		MEND	MCD13
8	ALM			ACD0
9	OP			ACD1
10	MBR			ACD2
11	DB (Note)			ACD3
12	ALCD0		PED	PRQ0
13	ALCD1			PRQ1
14	ALCD2			
15	BWNG			
16				
17			ALMWNG	
18			BW9F	
19		MSDH		
20		MSDL		
21		SOUT		
22		OUT1		
23		OUT2		
24		OUT3	PT0/PS0	
25	CDPS	CAMS	PT1/PS1	
26	CLDS (Note)	CLTS	PT2/PS2	
27	ABSV	CLTSM	PT3/PS3	
28		CLTS	PT4/PS4	
29			PT5/PS5	
30			PT6/PS6	
31	MTTR (Note)		PT7/PS7	

Note. This is not available with the MR-J4-03A6-RJ servo amplifier.

10. COMMUNICATION FUNCTION (MITSUBISHI GENERAL-PURPOSE AC SERVO PROTOCOL)

(b) "1 ___" (equivalent to MR-J3-T) is set to [Pr. PT01]

Bit	Symbol		
	Data No. [0] [0], [8] [0]	Data No. [0] [1], [8] [1]	Data No. [0] [2], [8] [2]
0	RD		MCD00
1			MCD01
2	ZSP		MCD02
3	TLC		MCD03
4			MCD10
5	INP		MCD11
6			MCD12
7	WNG		MCD13
8	ALM		ACD0
9			ACD1
10	MBR		ACD2
11	DB (Note)		ACD3
12			PRQ0
13			PRQ1
14			
15	BWNG		
16	CPO		
17	ZP		
18	POT		
19	PUS		
20			
21			
22			
23			
24		PT0	
25	CDPS	PT1	
26		PT2	
27		PT3	
28	MEND	PT4	
29		PT5	
30		PT6	
31		PT7	

Note. This is not available with the MR-J4-03A6-RJ servo amplifier.

(c) "2 ___" (equivalent to MR-J2S-CP) is set to [Pr. PT01]

Bit	Symbol		Bit	Symbol	
	Data No. [0] [0], [8] [0]			Data No. [0] [0], [8] [0]	
0	RD		16	CPO	
1			17	ZP	
2			18	POT	
3	TLC		19	PUS	
4			20	PT0	
5	INP		21	PT1	
6			22	PT2	
7	WNG		23	PT3	
8	ALM		24	PT4	
9			25		
10	MBR		26		
11	DB (Note)		27		
12			28	MEND	
13			29		
14			30		
15	BWNG		31		

Note. This is not available with the MR-J4-03A6-RJ servo amplifier.

10. COMMUNICATION FUNCTION (MITSUBISHI GENERAL-PURPOSE AC SERVO PROTOCOL)

(d) "3 ___" (equivalent to MR-J2S-CL) is set to [Pr. PT01]

Bit	Symbol	Bit	Symbol
	Data No. [0] [0], [8] [0]		Data No. [0] [0], [8] [0]
0	RD	16	
1		17	ZP
2		18	POT
3	TLC	19	PUS
4		20	OUT1
5		21	OUT2
6		22	OUT3
7	WNG	23	SOUT
8	ALM	24	PED
9		25	
10	MBR	26	
11	DB (Note)	27	
12		28	
13		29	
14		30	
15	BWNG	31	

Note. This is not available with the MR-J4-03A6-RJ servo amplifier.

11. MR-D01 EXTENSION I/O UNIT

11. MR-D01 EXTENSION I/O UNIT

MR-D01 is an extension I/O unit that can extend the input/output signals of MR-J4-_A_-RJ servo amplifiers.

POINT

- MR-D01 is available with servo amplifiers with software version B7 or later.
- MR-D01 cannot be used with the MR-J4-DU_A_-RJ drive unit.
- MR-D01 cannot be used with MR-J4-03A6-RJ servo amplifiers.

11. MR-D01 EXTENSION I/O UNIT

11.1 Function block diagram

The function block diagram of this servo is shown below.
The following illustration is an example of MR-J4-20A-RJ.

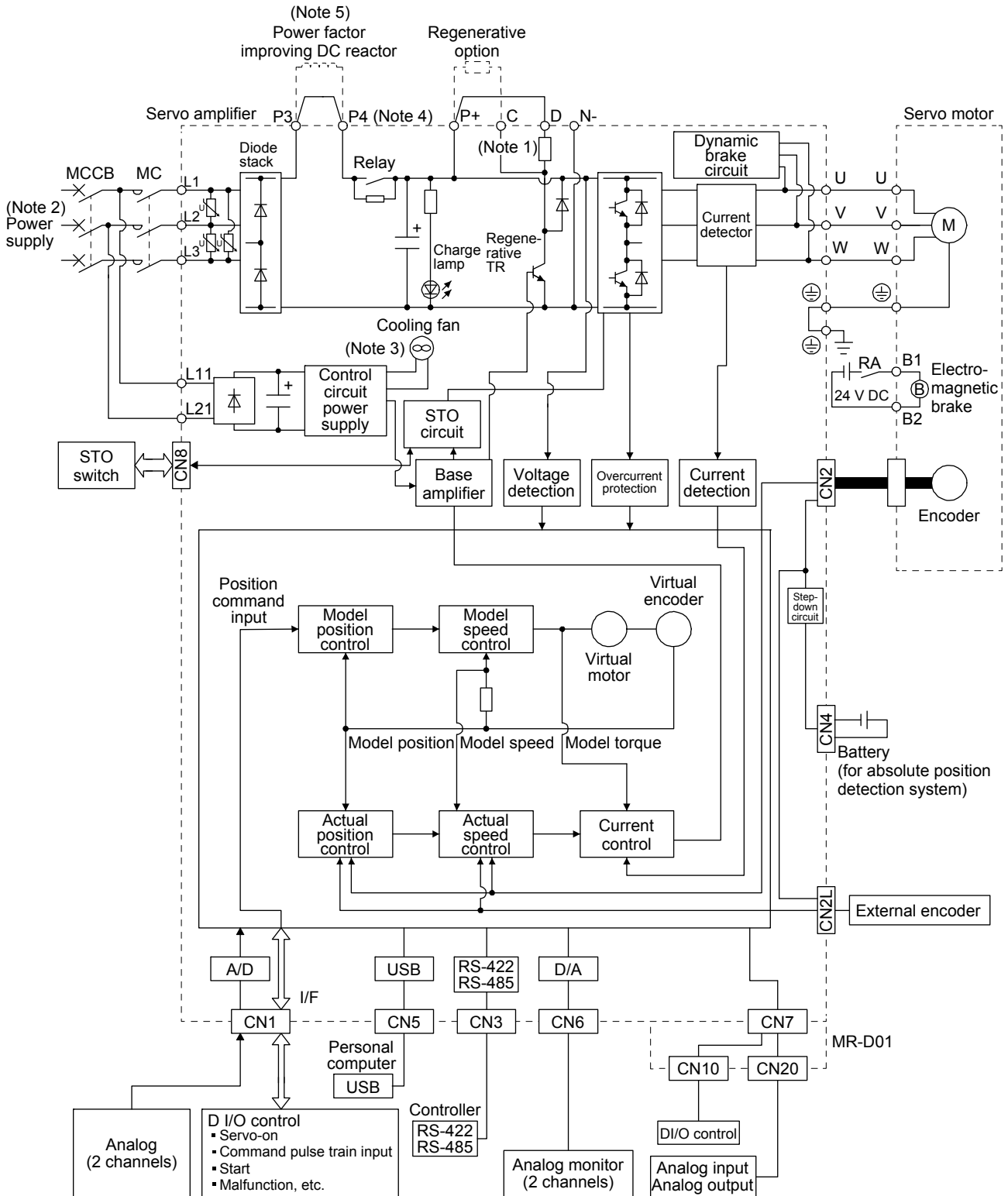

11. MR-D01 EXTENSION I/O UNIT

- Note
1. The built-in regenerative resistor is not provided for MR-J4-10A-RJ.
 2. For power supply specifications, refer to section 1.3 of "MR-J4-_A_(-RJ) Servo Amplifier Instruction Manual".
 3. Servo amplifiers MR-J4-70A-RJ or more have a cooling fan.
 4. MR-J4 servo amplifier has P3 and P4 in the upstream of the inrush current suppression circuit. They are different from P1 and P2 of MR-J3 servo amplifiers.
 5. The power factor improving AC reactor can also be used. In this case, the power factor improving DC reactor cannot be used. When not using the power factor improving DC reactor, short P3 and P4.

11. MR-D01 EXTENSION I/O UNIT

11.2 Structure

11.2.1 Parts identification

(1) Interface

The following figure shows the interface of when MR-J4-20A-RJ and MR-D01 have been connected. For servo amplifiers, refer to section 1.7.1 of "MR-J4-_A_(-RJ) Servo Amplifier Instruction Manual".

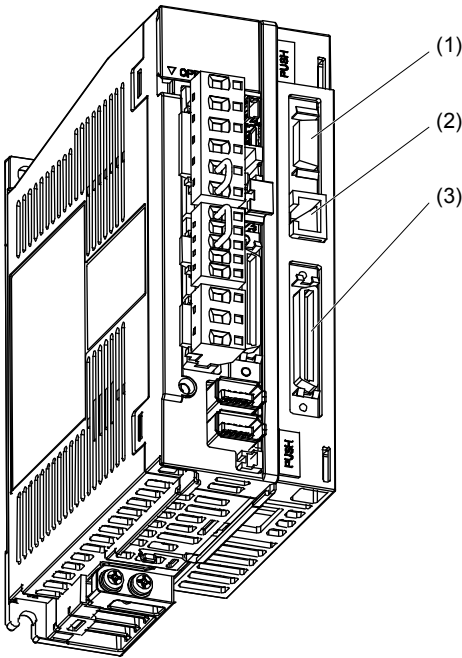

No.	Name/Application	Detailed explanation
(1)	Analog input signal connector (CN20) Connect analog input signals of analog torque limit and override.	Section 11.5.1
(2)	Manufacturer setting connector (CN30) This connector is attached on the MR-D01, but not for use.	
(3)	I/O signal connector (CN10) Connect digital I/O signal and analog output signal.	Section 11.5.1

(2) Rating plate

The following shows an example of the rating plate for explanation of each item.

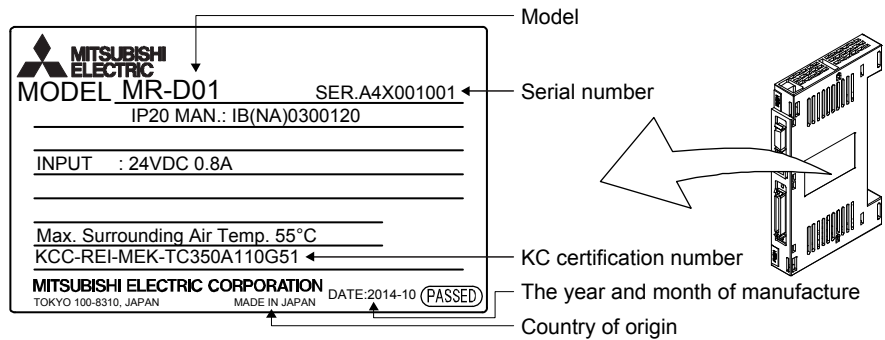

11. MR-D01 EXTENSION I/O UNIT

11.2.2 Installation and removal of the MR-D01 extension I/O unit

WARNING

- Before installing or removing MR-D01, turn off the power and wait for 15 minutes or more until the charge lamp of the servo amplifier turns off. Then, confirm that the voltage between P+ and N- is safe with a voltage tester and others. Otherwise, an electric shock may occur. In addition, when confirming whether the charge lamp is off or not, always confirm it from the front of the servo amplifier.

CAUTION

- Avoid installing and removing MR-D01 repeatedly. Any contact failure of the connector may be caused.
- Avoid unsealing MR-D01 to be free of dust and dirt against the connector except installing. Make sure to use the pre-packing when storing.
- Avoid using MR-D01 of which the hook and knobs for fixing are damaged. Any contact failure of the connector may be caused.
- When mounting/dismounting MR-D01 to/from MR-J4-500A-RJ to MR-J4-22KA-RJ and MR-J4-350A4-RJ to MR-J4-22KA4-RJ servo amplifiers, avoid dropping out the installing screw inside it. Otherwise, it may cause a malfunction.
- When mounting MR-D01 to MR-J4-500A-RJ to MR-J4-22KA-RJ and MR-J4-350A4-RJ to MR-J4-22KA4-RJ servo amplifiers, avoid damaging the control board by the fixing plate. Otherwise, it may cause a malfunction.
- Make sure to tighten MR-D01 with the enclosed installing screws when installing.

POINT

- The internal circuits of the servo amplifier and MR-D01 may be damaged by static electricity. Always take the following precautions.
 - Ground human body and work bench.
 - Do not touch the conductive areas, such as connector pins and electrical parts, directly by hand.

11. MR-D01 EXTENSION I/O UNIT

- (1) For MR-J4-200A(4)-RJ or less and MR-J4-350A-RJ
 (a) Installation of MR-D01

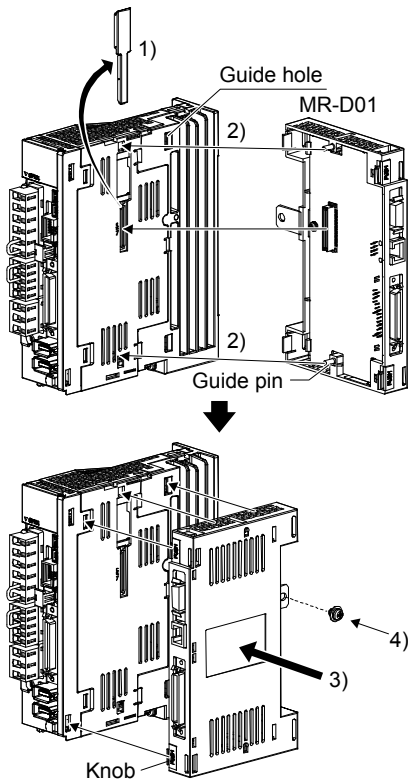

- 1) Remove the covers of CN7 and CN9 connectors. Make sure to store the removed cover.
- 2) Find the guide hole on the side of the servo amplifier. To the guide hole, insert the MR-D01's guide pins.

- 3) Push the four corners of the side of MR-D01 simultaneously to the servo amplifier until the four knobs click so that the CN7 connector is connected straight.
- 4) Tighten the unit with the enclosed installing screw (M4).

- (b) Removal of MR-D01

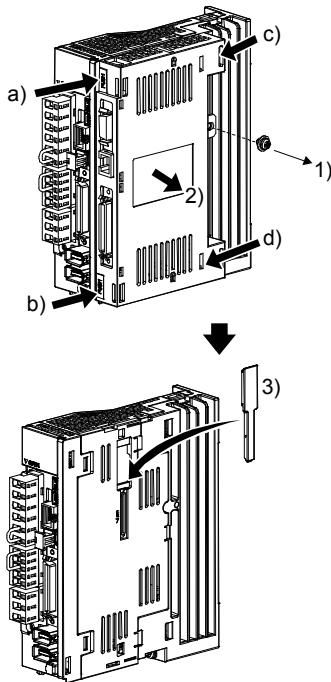

- 1) Remove the installing screw.
- 2) Keep pushing the knobs (a), (b), (c), (d) and pull out MR-D01 to the arrow direction. Avoid pulling out MR-D01 while it is tightened with the installation screw.

- 3) After removing MR-D01, make sure to cap the CN7 and CN9 connectors to avoid dust and dirt.

11. MR-D01 EXTENSION I/O UNIT

(2) MR-J4-500A-RJ to MR-J4-700A-RJ and MR-J4-350A4-RJ to MR-J4-700A4-RJ

(a) Removal of the side cover

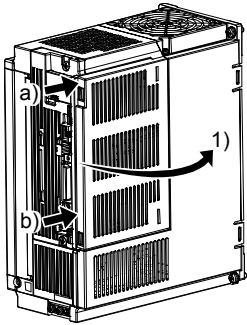

- 1) Keep pushing the knobs (a), b)) and pull out the side cover to the arrow direction.

(b) Installation of MR-D01

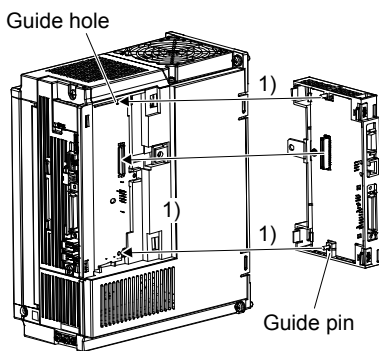

- 1) Find the guide hole on the side of the servo amplifier. To the guide hole, insert the MR-D01's guide pins.

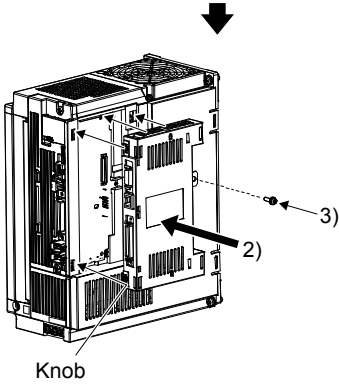

- 2) Push the four corners of the side of MR-D01 simultaneously to the servo amplifier until the four knobs click so that the CN7 connector is connected straight.
- 3) Tighten the unit with the enclosed installing screw (M4).

(c) Removal of MR-D01

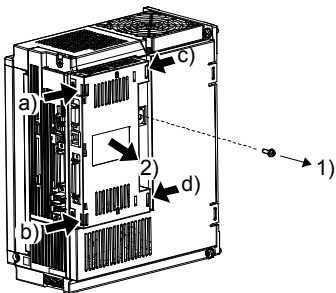

- 1) Remove the installing screw.
- 2) Keep pushing the knobs (a), b), c), d)) and pull out MR-D01 to the arrow direction. Avoid pulling out MR-D01 while it is tightened with the installation screw.

11. MR-D01 EXTENSION I/O UNIT

(d) Installation of the side cover

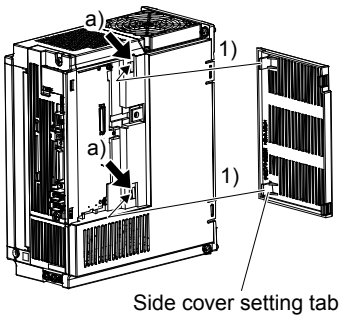

1) Insert the side cover setting tabs into the sockets a) of the servo amplifier.

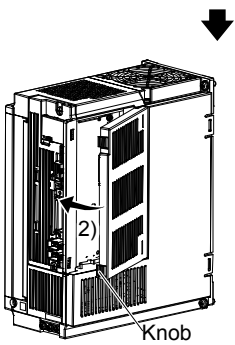

2) Push the side cover at the supporting point a) until the knobs click.

(3) MR-J4-11KA(4)-RJ to MR-J4-22KA(4)-RJ

CAUTION ● Avoid touching any remained burr after cutting off the part a) of the case. Otherwise, it may cause injury.

The installing screw holes for the MR-J4-11KA(4)-RJ to MR-J4-22KA(4)-RJ are covered and the screw holes for mounting are not shown at shipping. When installing the unit for the first time, cut off the part a) of the case after removing the side cover. When cutting off the part a), avoid damaging the case of the servo amplifier. After cutting off it, inside of the servo amplifier has been exposed even though the side cover and the unit are installed. Avoid unwanted parts from entering through the opened area into the servo amplifier. For installing or removing the unit, refer to (2) in this section. The side cover structure is the same for MR-J4-11KA(4)-RJ to MR-J4-22KA(4)-RJ and for this unit. Install or remove the side cover with the same way as for the unit.

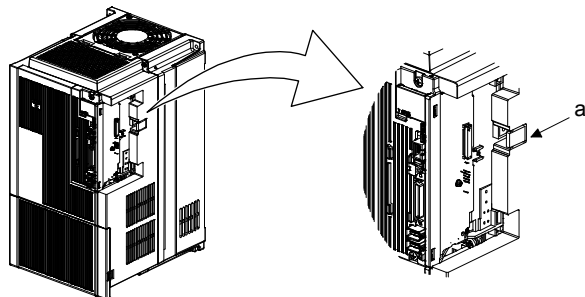

11. MR-D01 EXTENSION I/O UNIT

11.3 Configuration including peripheral equipment

CAUTION ● Connecting a servo motor of the wrong axis to U, V, W, or CN2 of the servo amplifier may cause a malfunction.

POINT

● Equipment other than the servo amplifier and servo motor are optional or recommended products.

The following figure shows the interface of when MR-D01 is connected to MR-J4-20A-RJ.

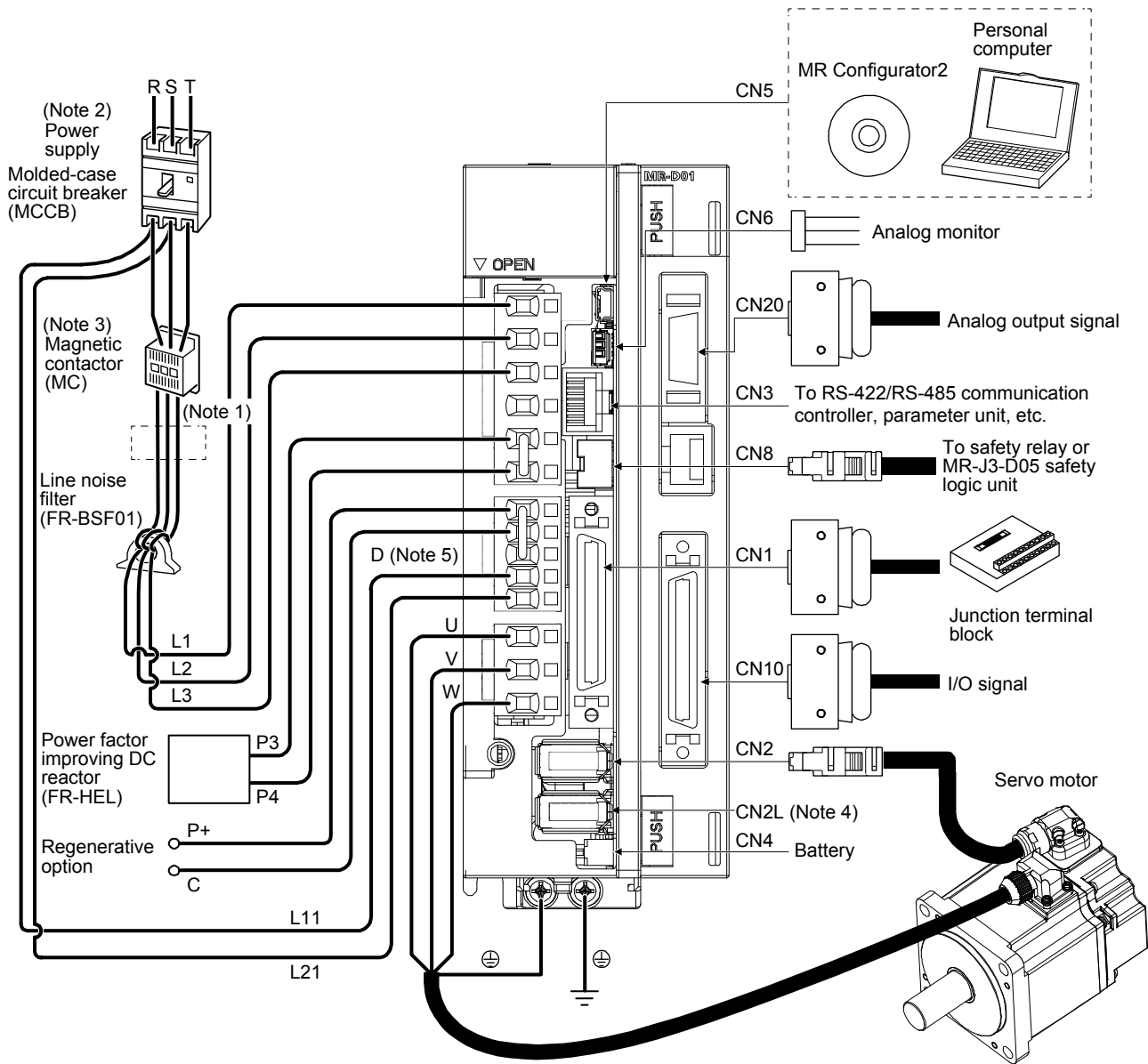

11. MR-D01 EXTENSION I/O UNIT

- Note
1. The power factor improving AC reactor can also be used. In this case, the power factor improving DC reactor cannot be used. When not using the power factor improving DC reactor, short P3 and P4.
 2. A 1-phase 200 V AC to 240 V AC power supply may be used with the servo amplifier of MR-J4-70A-RJ or less. For 1-phase 200 V AC to 240 V AC, connect the power supply to L1 and L3. Leave L2 open. For power supply specifications, refer to section 1.3 of "MR-J4-_A_(-RJ) Servo Amplifier Instruction Manual".
 3. Depending on the main circuit voltage and operation pattern, a bus voltage may drop, causing dynamic brake deceleration during forced stop deceleration. When dynamic brake deceleration is not required, delay the time to turn off the magnetic contactor.
 4. When using an MR-J4-_A-RJ servo amplifier in the linear servo system or in the fully closed loop system, connect an external encoder to this connector. Refer to Table 1.1 of "MR-J4-_A_(-RJ) Servo Amplifier Instruction Manual" and "Linear Encoder Instruction Manual" for the compatible external encoders.
 5. Always connect between P+ and D terminals. When using the regenerative option, refer to section 11.2 of "MR-J4-_A_(-RJ) Servo Amplifier Instruction Manual".

11. MR-D01 EXTENSION I/O UNIT

11.4 Installation direction and clearances

CAUTION	● The equipment must be installed in the specified direction. Otherwise, it may cause malfunction.
	● Leave specified clearances between the servo amplifier and cabinet walls or other equipment. Otherwise, it may cause malfunction.

- (1) Installation clearances of the servo amplifier
 - (a) Installation of one servo amplifier

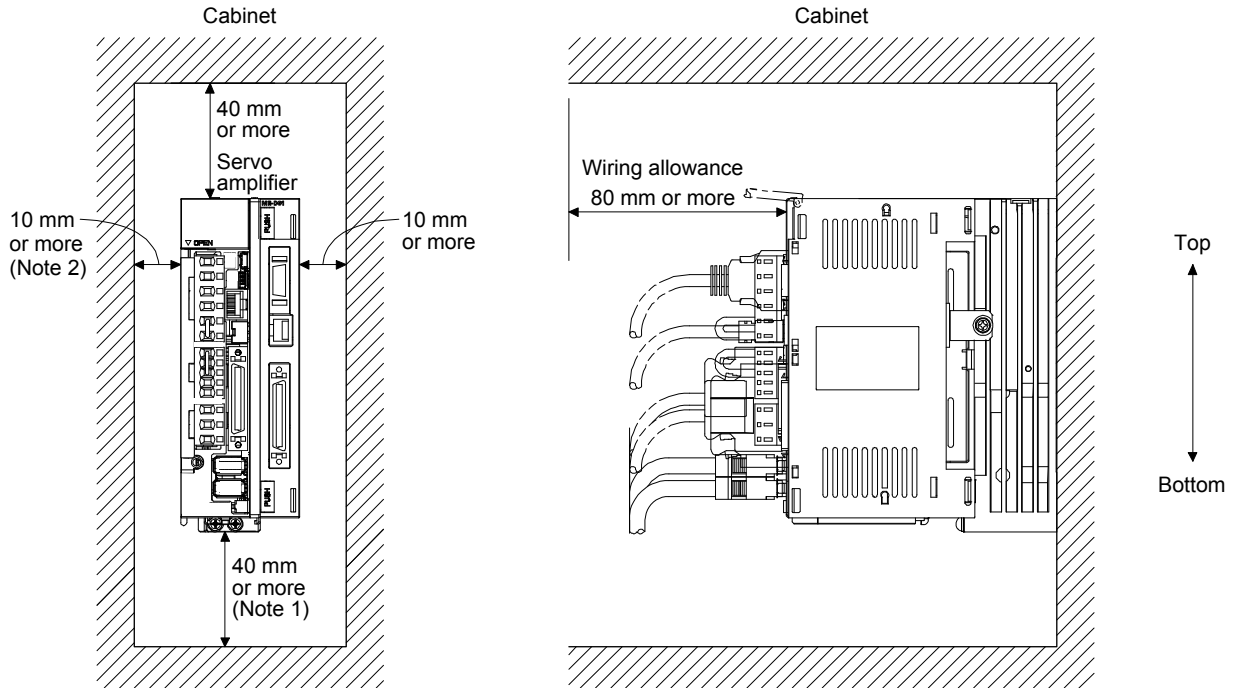

- Note 1. For the 11 kW to 22 kW servo amplifiers, the clearance between the bottom and the ground will be 120 mm or more.
- Note 2. When mounting MR-J4-500A-RJ, maintain a minimum clearance of 25 mm on the left side.

11. MR-D01 EXTENSION I/O UNIT

(b) Installation of two or more servo amplifiers

POINT
<ul style="list-style-type: none"> ● Close mounting is possible depending on the capacity of the servo amplifier. For the possibility of close mounting, refer to section 1.3 of "MR-J4-_A_(-RJ) Servo Amplifier Instruction Manual". ● When closely mounting multiple servo amplifiers, the servo amplifier on the right must have a larger depth than that on the left. Otherwise, the CNP1, CNP2, and CNP3 connectors cannot be removed.

Leave a large clearance between the top of the servo amplifier and the cabinet walls, and install a cooling fan to prevent the internal temperature of the cabinet from exceeding the environmental conditions.

When mounting the servo amplifiers closely, leave a clearance of 1 mm between the adjacent servo amplifiers in consideration of mounting tolerances. In this case, operate the servo amplifiers at the ambient temperature of 0 °C to 45 °C or at 75% or less of the effective load ratio.

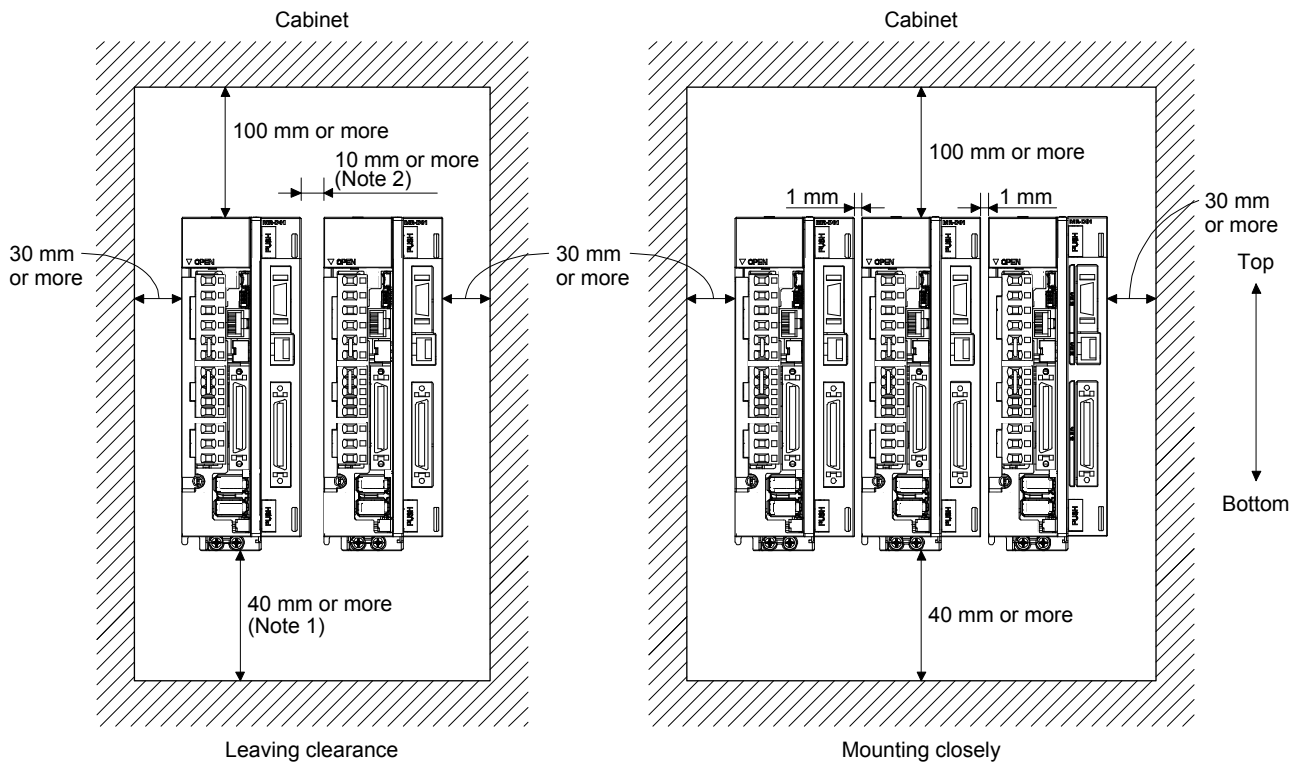

- Note 1. For the 11 kW to 22 kW servo amplifiers, the clearance between the bottom and the ground will be 120 mm or more.
 Note 2. When mounting MR-J4-500A-RJ, maintain a minimum clearance of 25 mm between the MR-J4-500A-RJ and a servo amplifier mounted on the left side.

(2) Others

When using heat generating equipment such as the regenerative option, install them with full consideration of heat generation so that the servo amplifier is not affected.

Install the servo amplifier on a perpendicular wall in the correct vertical direction.

11. MR-D01 EXTENSION I/O UNIT

11.5 Signals and wiring

POINT																	
<p>● Input signals of the servo amplifier are valid even when the MR-D01 has been connected. When the same input devices have been assigned to the servo amplifier and MR-D01 and both input signals are turned on, the input signal that has turned on first is enabled. Even though turning off one of the input signals that have been turned on is attempted, the input signal cannot be turned off. Refer to the following table for details. The following table shows ST1 (Forward rotation start) as an example.</p>																	
<table border="1"><thead><tr><th>Device</th><th>(Note) Servo amplifier</th><th>(Note) MR-D01</th><th>Servo motor</th></tr></thead><tbody><tr><td rowspan="4">ST1</td><td>0</td><td>0</td><td>Stop</td></tr><tr><td>0</td><td>1</td><td>Forward rotation</td></tr><tr><td>1</td><td>0</td><td>Forward rotation</td></tr><tr><td>1</td><td>1</td><td>Forward rotation</td></tr></tbody></table>	Device	(Note) Servo amplifier	(Note) MR-D01	Servo motor	ST1	0	0	Stop	0	1	Forward rotation	1	0	Forward rotation	1	1	Forward rotation
Device	(Note) Servo amplifier	(Note) MR-D01	Servo motor														
ST1	0	0	Stop														
	0	1	Forward rotation														
	1	0	Forward rotation														
	1	1	Forward rotation														
<p>Note. 0: Off 1: On</p>																	

11. MR-D01 EXTENSION I/O UNIT

11.5.1 I/O signal connection diagram

(1) Point table method

POINT
<ul style="list-style-type: none"> Assign the following output devices to CN1-22, CN1-23, and CN1-25 pins with [Pr. PD23], [Pr. PD24], and [Pr. PD26]. CN1-22: CPO (Rough match) CN1-23: ZP (Home position return completion) CN1-25: MEND (Travel completion)

(a) Sink I/O interface

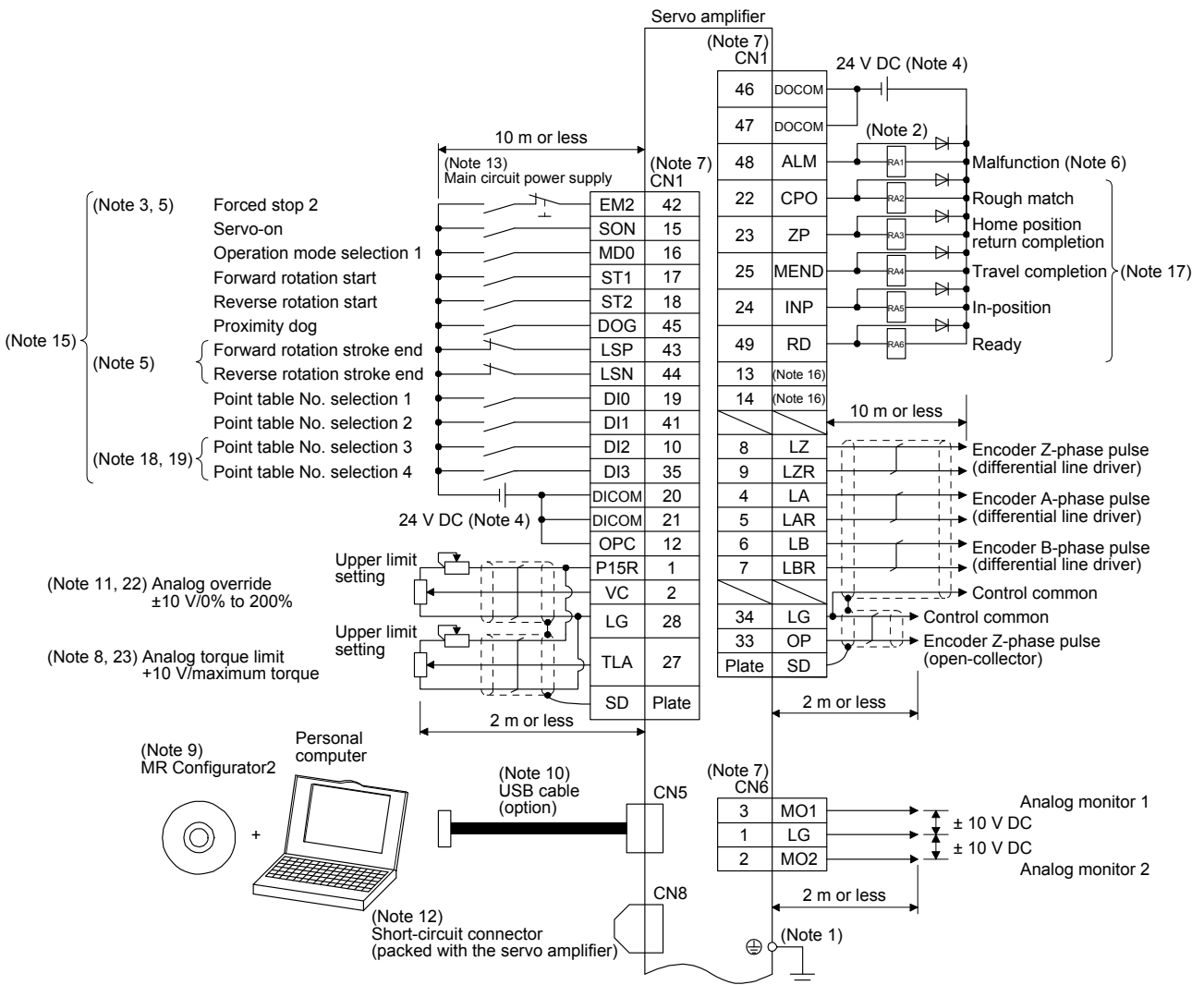

11. MR-D01 EXTENSION I/O UNIT

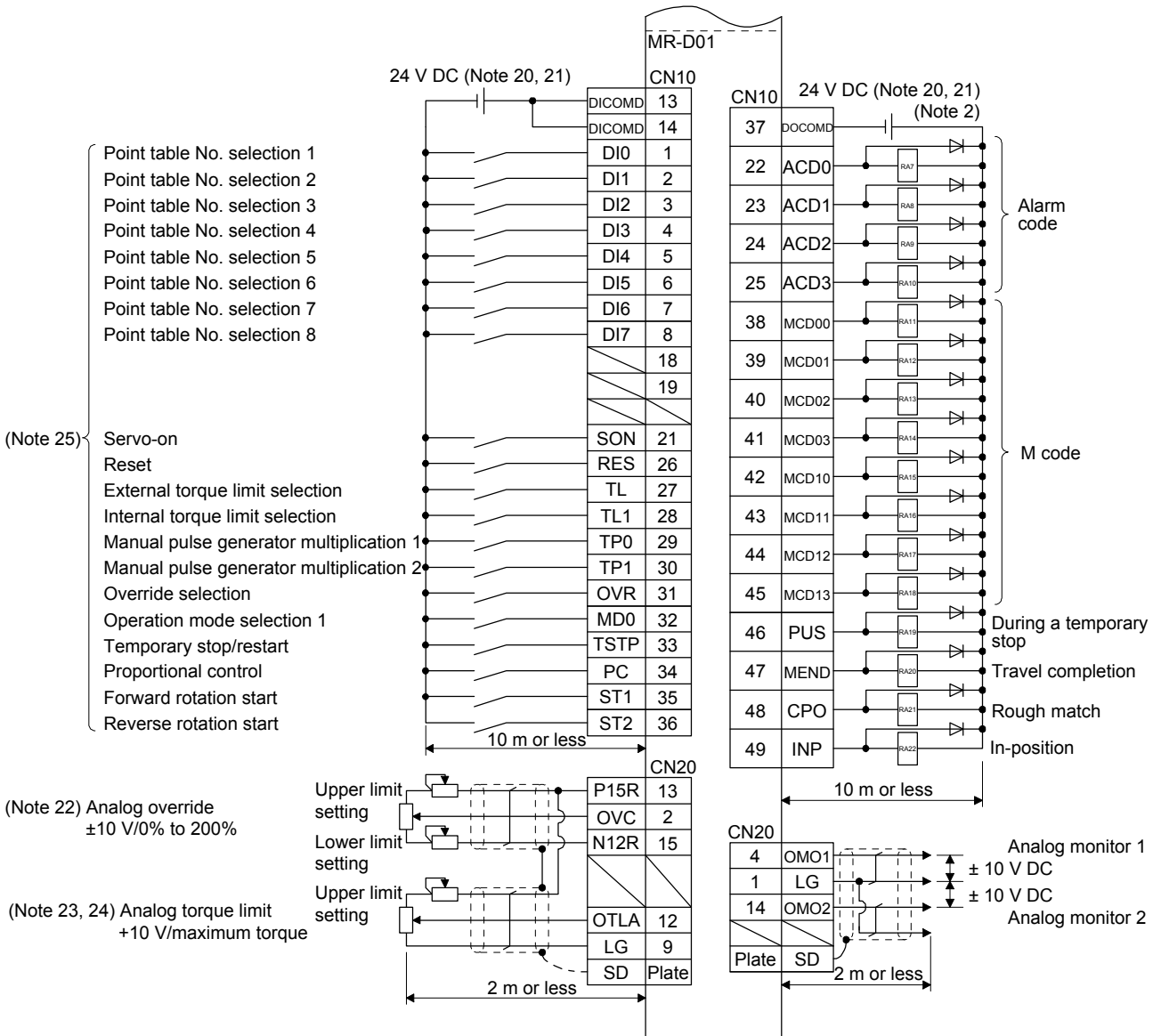

11. MR-D01 EXTENSION I/O UNIT

- Note
- To prevent an electric shock, always connect the protective earth (PE) terminal (marked \oplus) of the servo amplifier to the protective earth (PE) of the cabinet.
 - Connect the diode in the correct direction. If it is connected reversely, the servo amplifier will malfunction and will not output signals, disabling EM2 (Forced stop 2) and other protective circuits.
 - The forced stop switch (normally closed contact) must be installed.
 - Supply 24 V DC \pm 10% to interfaces from outside. The total current capacity of these power supplies must be 500 mA or lower. 500 mA is the value applicable when all I/O signals are used. The current capacity can be decreased by reducing the number of I/O points. Refer to section 3.9.2 (1) of "MR-J4-_A_(-RJ) Servo Amplifier Instruction Manual" that gives the current value necessary for the interface. A 24 V DC power supply can be used for both input signal and output signal.
 - When starting operation, always turn on EM2 (Forced stop 2), LSP (Forward rotation stroke end) and LSN (Reverse rotation stroke end). (Normally closed contact)
 - ALM (Malfunction) turns on in normal alarm-free condition. (Normally closed contact)
 - The pins with the same signal name are connected in the servo amplifier.
 - TLA will be available when TL (External torque limit selection) is enabled with [Pr. PD04], [Pr. PD06], [Pr. PD08], [Pr. PD10], [Pr. PD12], [Pr. PD14], [Pr. PD18], [Pr. PD20], [Pr. PD22], [Pr. PD44], and [Pr. PD46]. (Refer to section 3.6.1 (5) of "MR-J4-_A_(-RJ) Servo Amplifier Instruction Manual".)
 - Use SW1DNC MRC2_-. (Refer to "MR-J4-_A_(-RJ) Servo Amplifier Instruction Manual" section 11.7.)
 - Controllers or parameter units can also be connected via the CN3 connector with the RS-422/RS-485 communication. Note that using the USB communication function (CN5 connector) prevents the RS-422/RS-485 communication function (CN3 connector) from being used, and vice versa. They cannot be used together.

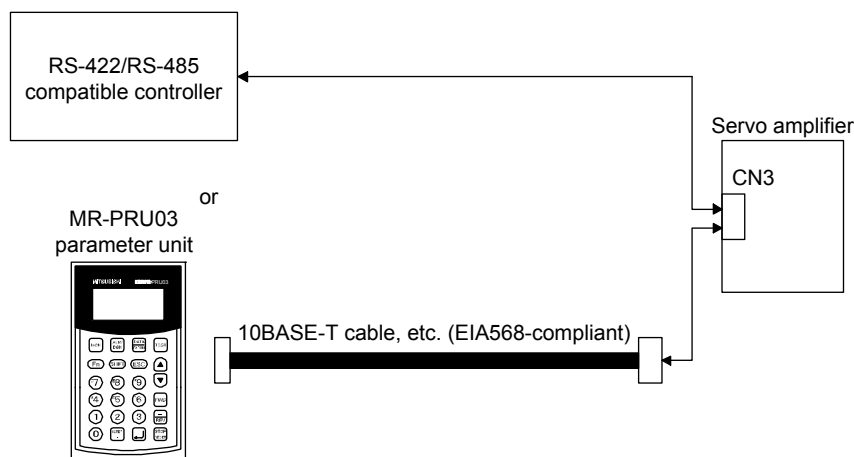

- Use an external power supply when inputting a negative voltage.
- When not using the STO function, attach the short-circuit connector came with a servo amplifier.
- Configure a circuit to turn off EM2 when the main circuit power is turned off to prevent an unexpected restart of the servo amplifier.
- The CN1-10 pin, CN1-12 pin, and CN1-35 pin cannot be used with source input interfaces.
- The devices can be changed with [Pr. PD04], [Pr. PD06], [Pr. PD08], [Pr. PD10], [Pr. PD12], [Pr. PD14], [Pr. PD18], [Pr. PD20], [Pr. PD22], [Pr. PD44], and [Pr. PD46].
- Output devices are not assigned by default. Assign the output devices with [Pr. PD47] as necessary.
- Recommended device assignments are shown. The devices can be changed by [Pr. PD23] to [Pr. PD26], and [Pr. PD28].
- DI2 and DI3 are assigned to the CN1-10 and CN1-35 pins by default. When connecting a manual pulse generator, change them with [Pr. PD44] and [Pr. PD46]. Refer to section 9.1 for details of the manual pulse generator.
- Supply + of 24 DC V to OPC (Power input for open-collector sink interface) when input devices are assigned to the CN1-10 pin and the CN-35 pin. They cannot be used with source input interface. For the positioning mode, input devices (DI2 and DI3) are assigned with the initial values.
- Supply 24 V DC \pm 10% to interfaces of the MR-D01 from outside. The total current capacity of these power supplies must be 800 mA or lower. 800 mA is the value applicable when all I/O signals are used. The current capacity can be decreased by reducing the number of I/O points. For the current required for the interface, refer to section 3.8.2 (1) of "MR-J4-_A_(-RJ) Servo Amplifier Instruction Manual".
- As the 24 V DC for the input/output signals, one 24 V DC power supply can be used to supply to the servo amplifier and MR-D01. In this case, select an appropriate power supply capacity depending on the number of points of the input/output signals to be used.
- The CN1-2 pin and CN20-2 pin are exclusive. The CN1-2 pin is set by default. Select this item with [Pr. Po11].
- The CN1-27 pin and CN20-12 pin are exclusive. The CN1-27 pin is set by default. Select this item with [Pr. Po11].
- OTLA will be available when TL (External torque limit selection) is enabled with [Pr. Po02] to [Pr. Po07]. (Refer to section 11.5.3 (6).)
- The devices can be changed by [Pr. Po02] to [Pr. Po07].
- When using the point table No. selection 3 and point table No. selection 4 with a source input interface, configure the circuit as shown in the figure.

11. MR-D01 EXTENSION I/O UNIT

(b) Source I/O interface

POINT
 ● For notes, refer to (1) (a) of this section.

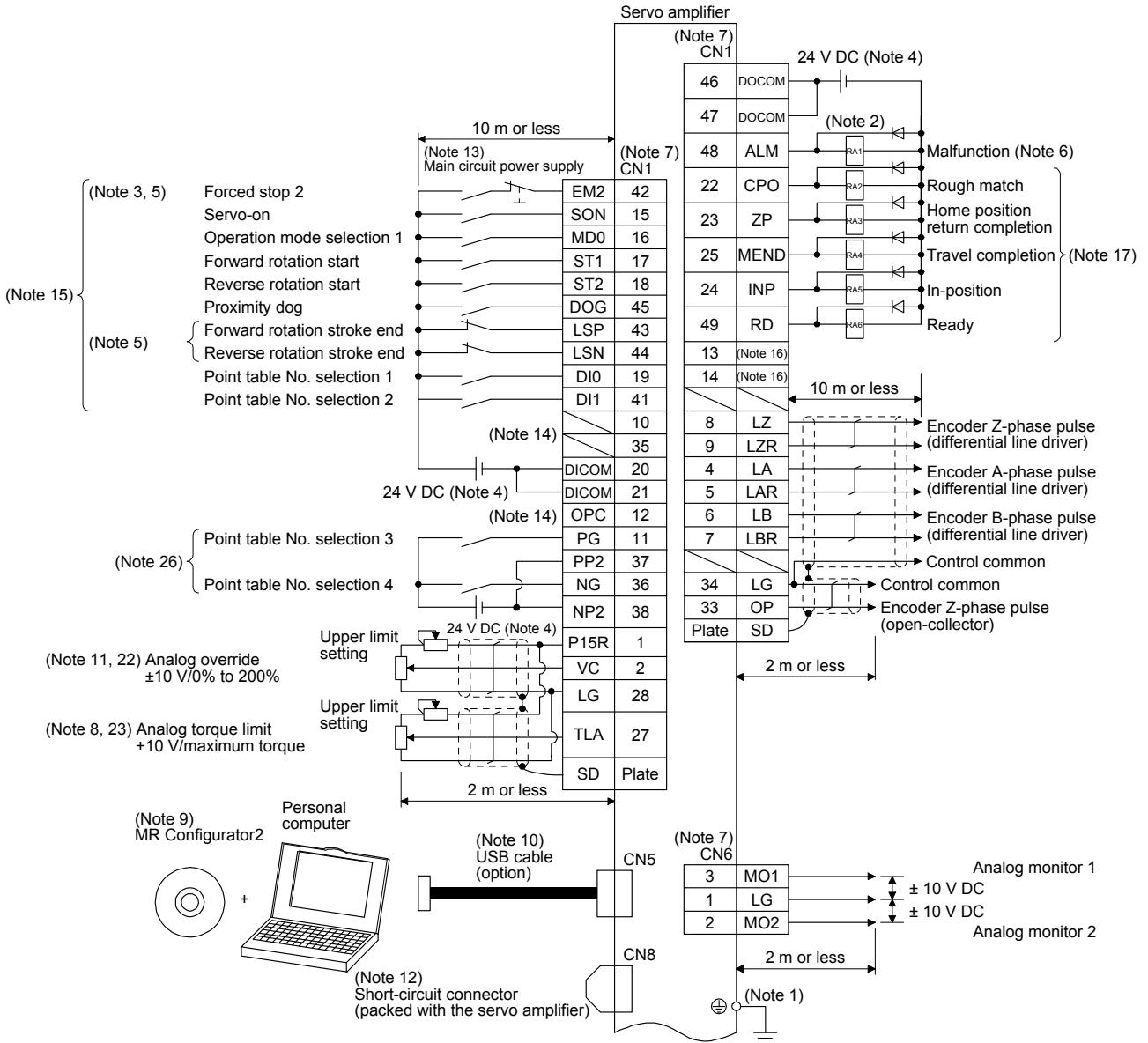

11. MR-D01 EXTENSION I/O UNIT

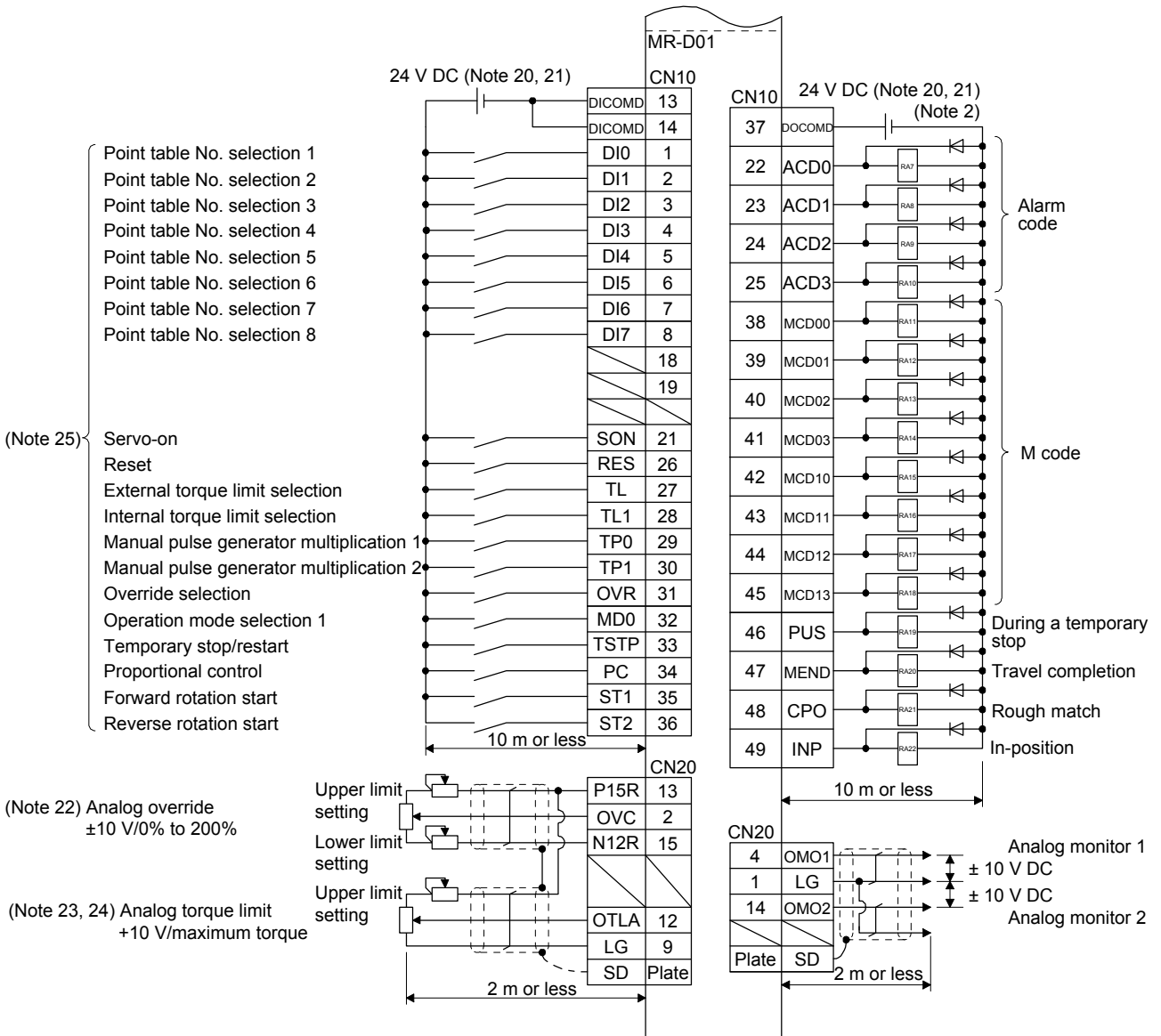

11. MR-D01 EXTENSION I/O UNIT

(2) Point table method in the BCD input positioning operation

POINT
●Assign the following output devices to CN1-22, CN1-23, and CN1-25 pins with [Pr. PD23], [Pr. PD24], and [Pr. PD26]. CN1-22: CPO (Rough match) CN1-23: ZP (Home position return completion) CN1-25: MEND (Travel completion)

11. MR-D01 EXTENSION I/O UNIT

- (a) When using a digital switch
 1) Sink I/O interface

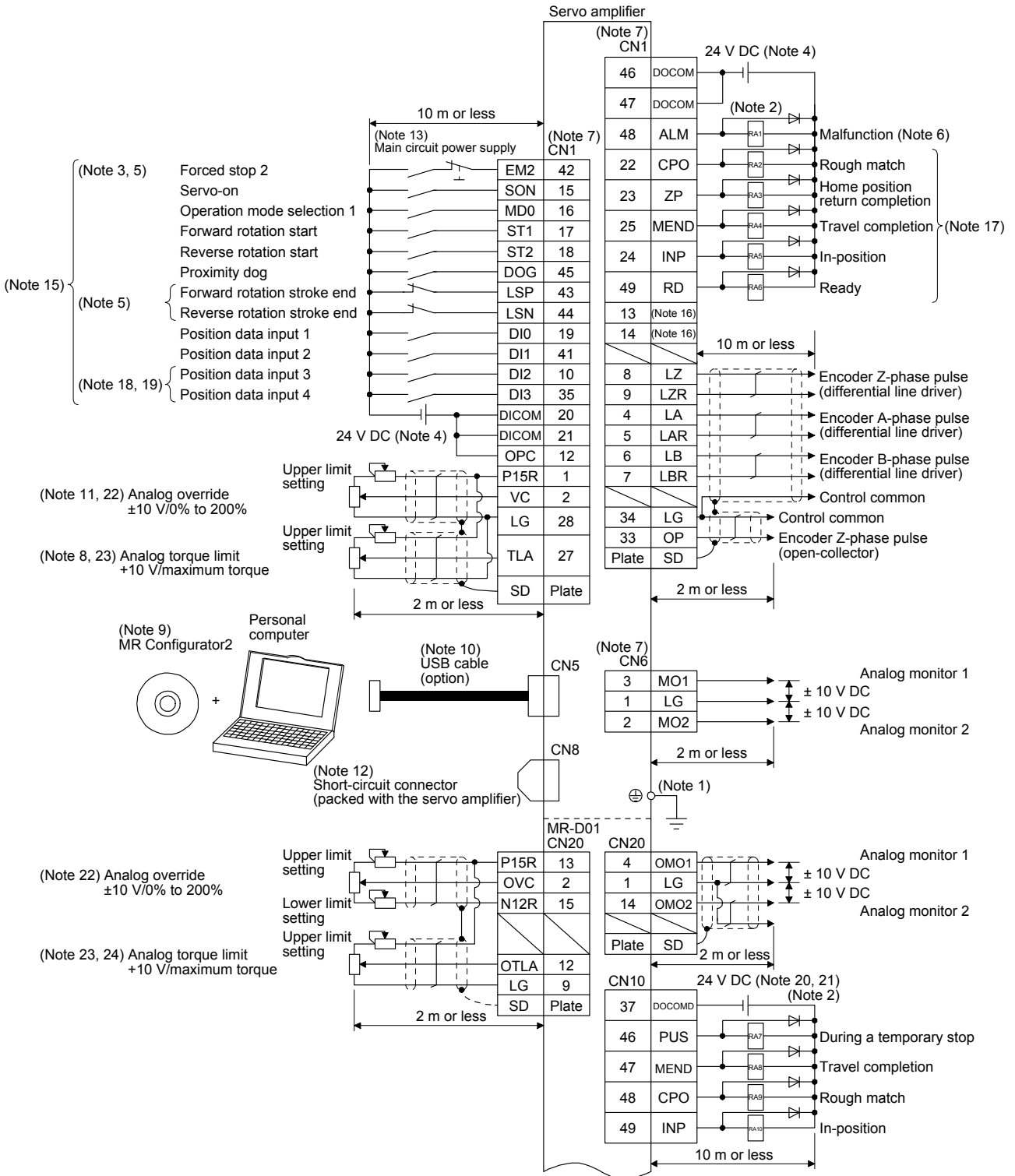

11. MR-D01 EXTENSION I/O UNIT

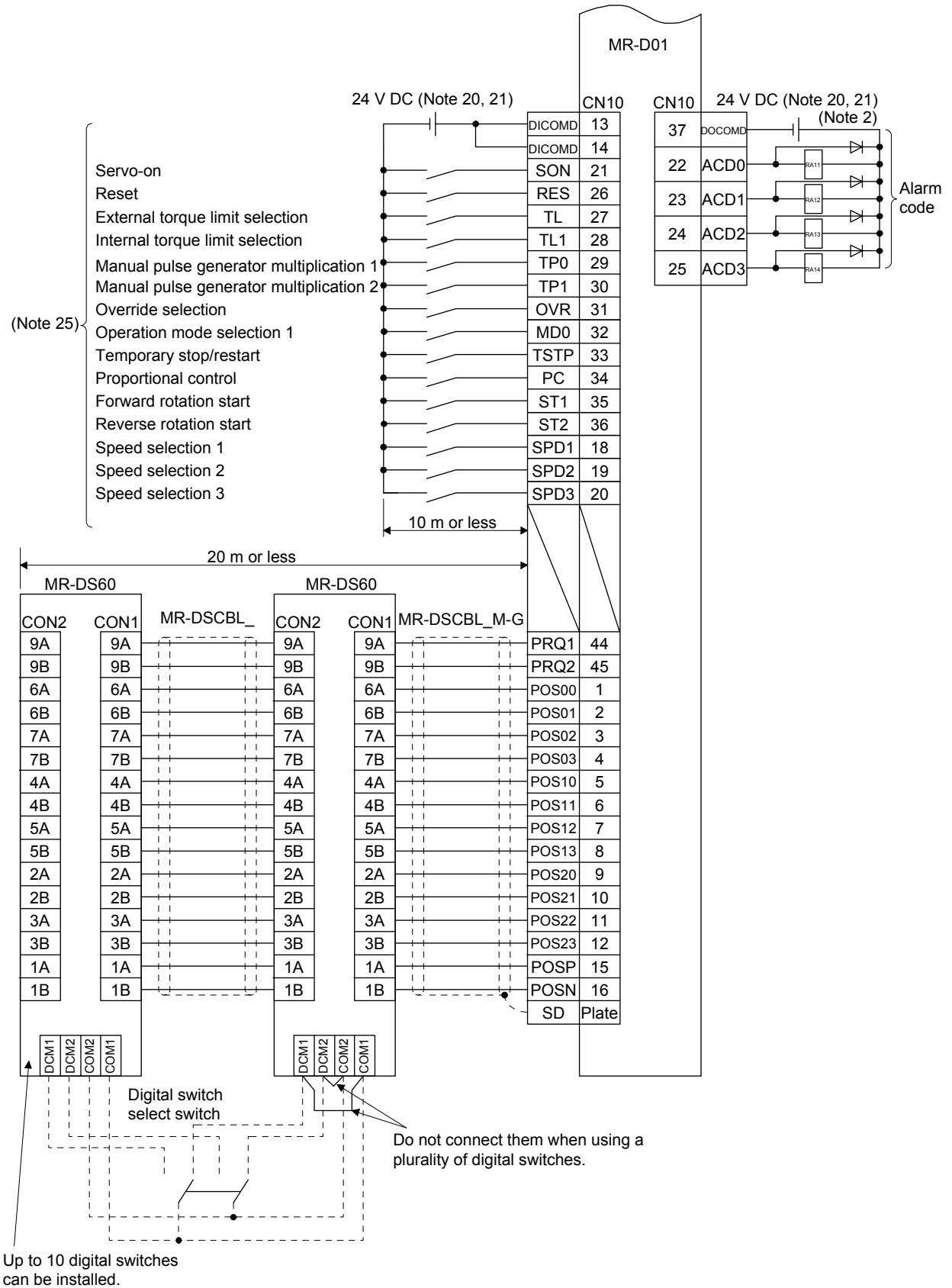

11. MR-D01 EXTENSION I/O UNIT

- Note
- To prevent an electric shock, always connect the protective earth (PE) terminal (marked \oplus) of the servo amplifier to the protective earth (PE) of the cabinet.
 - Connect the diode in the correct direction. If it is connected reversely, the servo amplifier will malfunction and will not output signals, disabling EM2 (Forced stop 2) and other protective circuits.
 - The forced stop switch (normally closed contact) must be installed.
 - Supply 24 V DC \pm 10% to interfaces from outside. The total current capacity of these power supplies must be 500 mA or lower. 500 mA is the value applicable when all I/O signals are used. The current capacity can be decreased by reducing the number of I/O points. Refer to section 3.9.2 (1) of "MR-J4-_A_(-RJ) Servo Amplifier Instruction Manual" that gives the current value necessary for the interface. A 24 V DC power supply can be used for both input signal and output signal.
 - When starting operation, always turn on EM2 (Forced stop 2), LSP (Forward rotation stroke end) and LSN (Reverse rotation stroke end). (Normally closed contact)
 - ALM (Malfunction) turns on in normal alarm-free condition. (Normally closed contact)
 - The pins with the same signal name are connected in the servo amplifier.
 - TLA will be available when TL (External torque limit selection) is enabled with [Pr. PD04], [Pr. PD06], [Pr. PD08], [Pr. PD10], [Pr. PD12], [Pr. PD14], [Pr. PD18], [Pr. PD20], [Pr. PD22], [Pr. PD44], and [Pr. PD46]. (Refer to section 3.6.1 (5) of "MR-J4-_A_(-RJ) Servo Amplifier Instruction Manual".)
 - Use SW1DNC MRC2-_ (Refer to "MR-J4-_A_(-RJ) Servo Amplifier Instruction Manual" section 11.7.)
 - Controllers or parameter units can also be connected via the CN3 connector with the RS-422/RS-485 communication. Note that using the USB communication function (CN5 connector) prevents the RS-422/RS-485 communication function (CN3 connector) from being used, and vice versa. They cannot be used together.

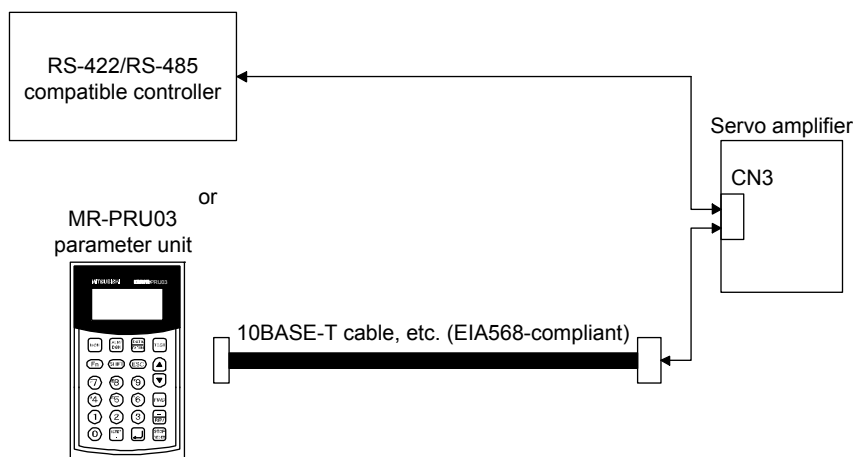

- Use an external power supply when inputting a negative voltage.
- When not using the STO function, attach the short-circuit connector came with a servo amplifier.
- Configure a circuit to turn off EM2 when the main circuit power is turned off to prevent an unexpected restart of the servo amplifier.
- The CN1-10 pin, CN1-12 pin, and CN1-35 pin cannot be used with source input interfaces.
- The devices can be changed with [Pr. PD04], [Pr. PD06], [Pr. PD08], [Pr. PD10], [Pr. PD12], [Pr. PD14], [Pr. PD18], [Pr. PD20], [Pr. PD22], [Pr. PD44], and [Pr. PD46].
- Output devices are not assigned by default. Assign the output devices with [Pr. PD47] as necessary.
- Recommended device assignments are shown. The devices can be changed by [Pr. PD23] to [Pr. PD26], and [Pr. PD28].
- DI2 and DI3 are assigned to the CN1-10 and CN1-35 pins by default. When connecting a manual pulse generator, change them with [Pr. PD44] and [Pr. PD46]. Refer to section 9.1 for details of the manual pulse generator.
- Supply + of 24 DC V to OPC (Power input for open-collector sink interface) when input devices are assigned to the CN1-10 pin and the CN-35 pin. They cannot be used with source input interface. For the positioning mode, input devices (DI2 and DI3) are assigned with the initial values.
- Supply 24 V DC \pm 10% to interfaces of the MR-D01 from outside. The total current capacity of these power supplies must be 800 mA or lower. 800 mA is the value applicable when all I/O signals are used. The current capacity can be decreased by reducing the number of I/O points. For the current required for the interface, refer to section 3.8.2 (1) of "MR-J4-_A_(-RJ) Servo Amplifier Instruction Manual".
- As the 24 V DC for the input/output signals, one 24 V DC power supply can be used to supply to the servo amplifier and MR-D01. In this case, select an appropriate power supply capacity depending on the number of points of the input/output signals to be used.
- The CN1-2 pin and CN20-2 pin are exclusive. The CN1-2 pin is set by default. Select this item with [Pr. Po11].
- The CN1-27 pin and CN20-12 pin are exclusive. The CN1-27 pin is set by default. Select this item with [Pr. Po11].
- OTLA will be available when TL (External torque limit selection) is enabled with [Pr. Po02] to [Pr. Po07]. (Refer to section 11.5.3 (6).)
- The devices can be changed by [Pr. Po02] to [Pr. Po07].
- When using position data input 3 and position data input 4 with a source input interface, configure the circuit as shown in the figure.

11. MR-D01 EXTENSION I/O UNIT

2) Source I/O interface

POINT

● For notes, refer to (2) (a) 1) of this section.

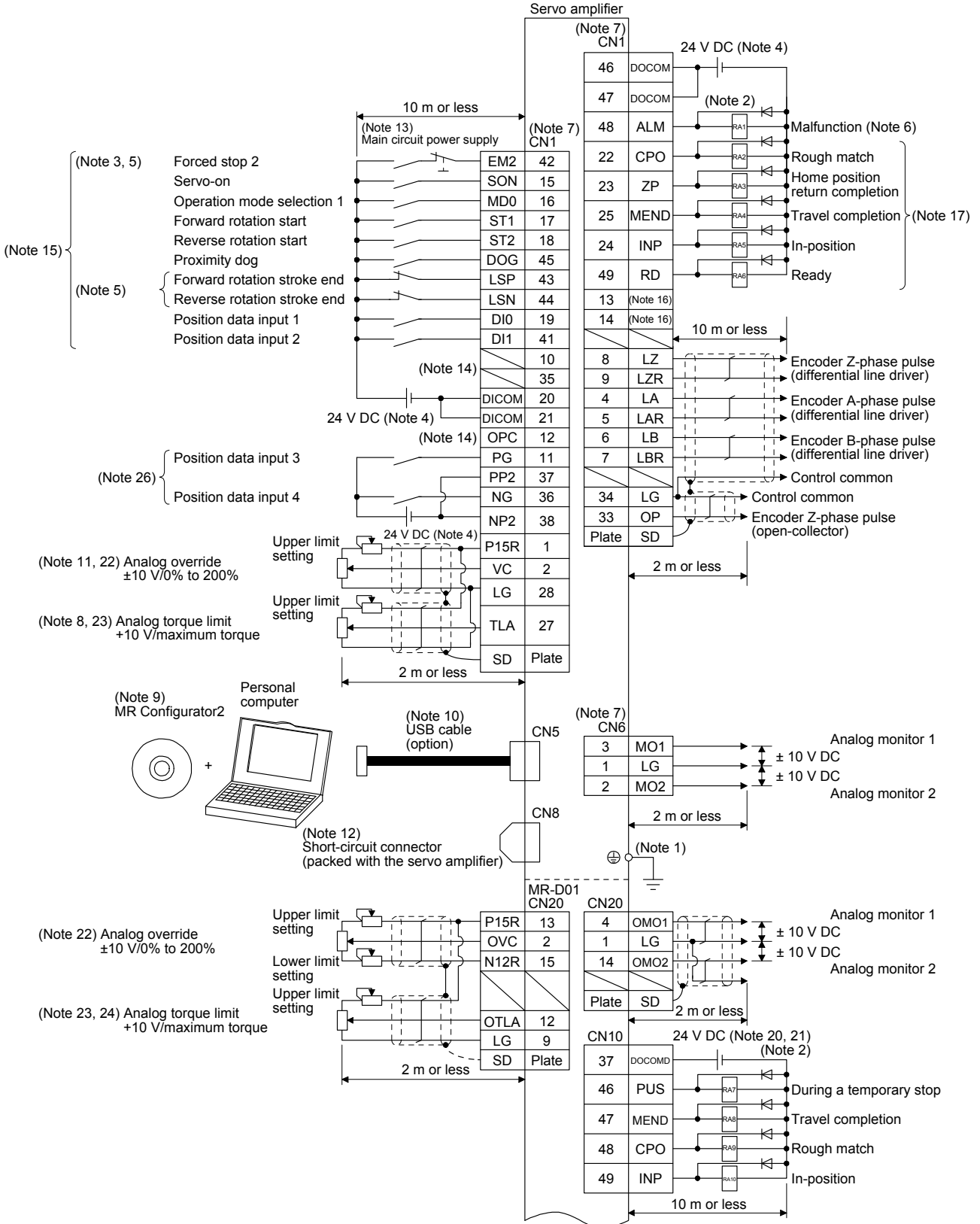

11. MR-D01 EXTENSION I/O UNIT

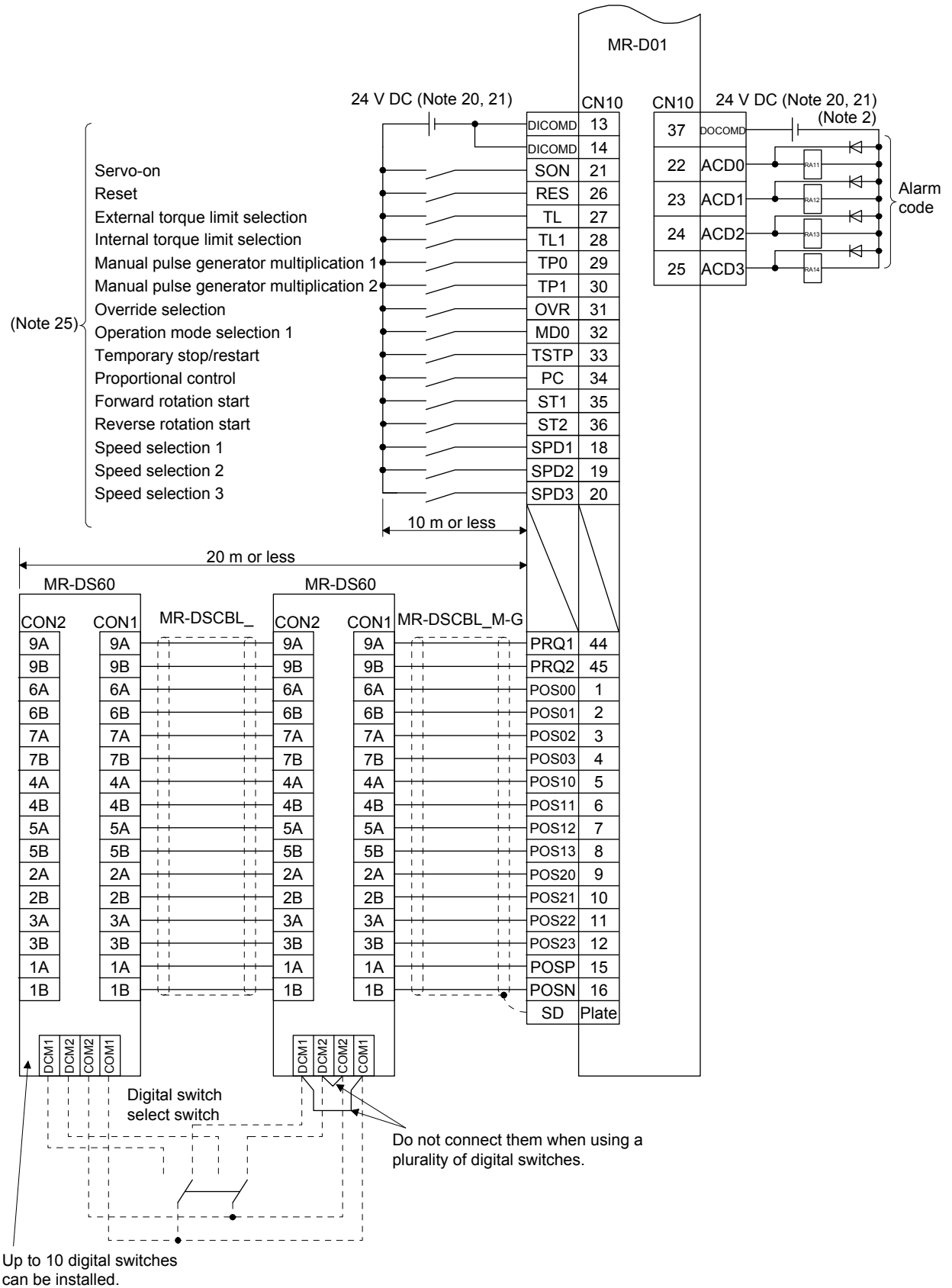

11. MR-D01 EXTENSION I/O UNIT

- (b) When using programmable controllers
 1) Sink I/O interface

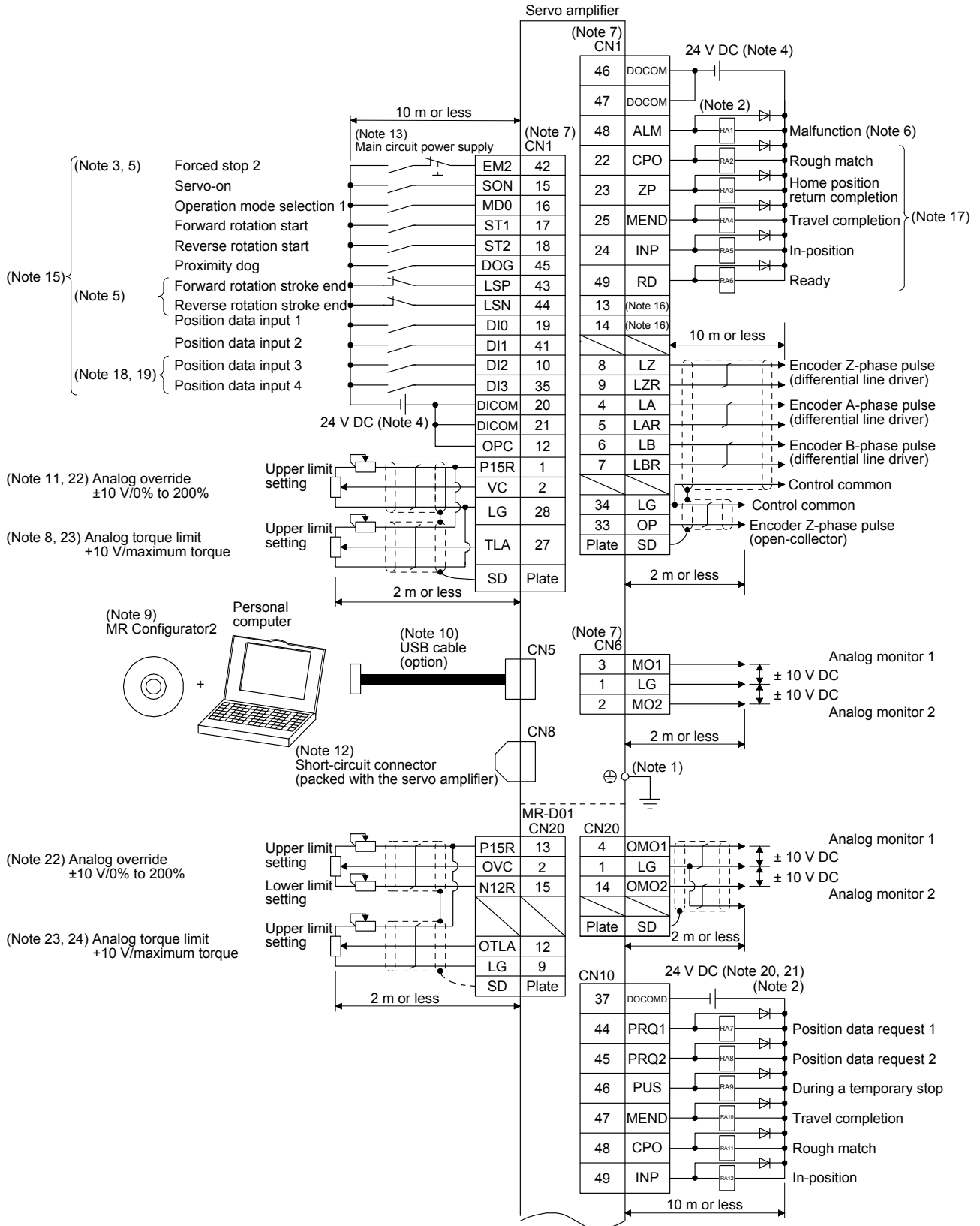

11. MR-D01 EXTENSION I/O UNIT

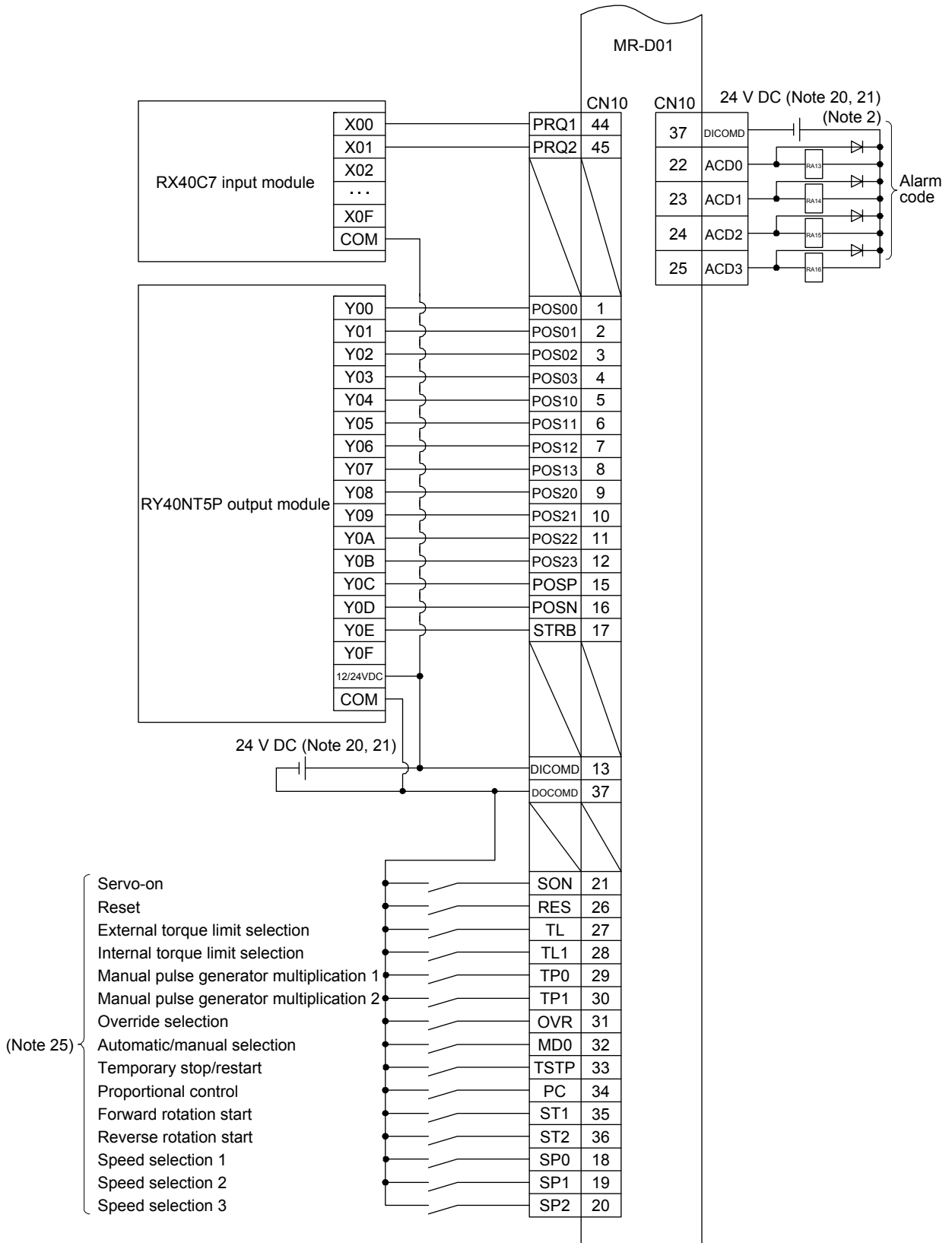

11. MR-D01 EXTENSION I/O UNIT

- Note
- To prevent an electric shock, always connect the protective earth (PE) terminal (marked \oplus) of the servo amplifier to the protective earth (PE) of the cabinet.
 - Connect the diode in the correct direction. If it is connected reversely, the servo amplifier will malfunction and will not output signals, disabling EM2 (Forced stop 2) and other protective circuits.
 - The forced stop switch (normally closed contact) must be installed.
 - Supply 24 V DC \pm 10% to interfaces from outside. The total current capacity of these power supplies must be 500 mA or lower. 500 mA is the value applicable when all I/O signals are used. The current capacity can be decreased by reducing the number of I/O points. Refer to section 3.9.2 (1) of "MR-J4-_A_(-RJ) Servo Amplifier Instruction Manual" that gives the current value necessary for the interface. A 24 V DC power supply can be used for both input signal and output signal.
 - When starting operation, always turn on EM2 (Forced stop 2), LSP (Forward rotation stroke end) and LSN (Reverse rotation stroke end). (Normally closed contact)
 - ALM (Malfunction) turns on in normal alarm-free condition. (Normally closed contact)
 - The pins with the same signal name are connected in the servo amplifier.
 - TLA will be available when TL (External torque limit selection) is enabled with [Pr. PD04], [Pr. PD06], [Pr. PD08], [Pr. PD10], [Pr. PD12], [Pr. PD14], [Pr. PD18], [Pr. PD20], [Pr. PD22], [Pr. PD44], and [Pr. PD46]. (Refer to section 3.6.1 (5) of "MR-J4-_A_(-RJ) Servo Amplifier Instruction Manual".)
 - Use SW1DNC MRC2-_ (Refer to "MR-J4-_A_(-RJ) Servo Amplifier Instruction Manual" section 11.7.)
 - Controllers or parameter units can also be connected via the CN3 connector with the RS-422/RS-485 communication. Note that using the USB communication function (CN5 connector) prevents the RS-422/RS-485 communication function (CN3 connector) from being used, and vice versa. They cannot be used together.

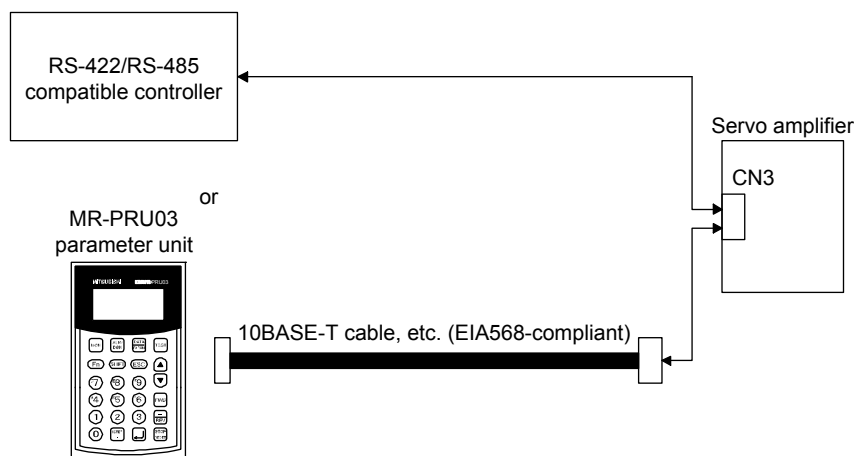

- Use an external power supply when inputting a negative voltage.
- When not using the STO function, attach the short-circuit connector came with a servo amplifier.
- Configure a circuit to turn off EM2 when the main circuit power is turned off to prevent an unexpected restart of the servo amplifier.
- The CN1-10 pin, CN1-12 pin, and CN1-35 pin cannot be used with source input interfaces.
- The devices can be changed with [Pr. PD04], [Pr. PD06], [Pr. PD08], [Pr. PD10], [Pr. PD12], [Pr. PD14], [Pr. PD18], [Pr. PD20], [Pr. PD22], [Pr. PD44], and [Pr. PD46].
- Output devices are not assigned by default. Assign the output devices with [Pr. PD47] as necessary.
- Recommended device assignments are shown. The devices can be changed by [Pr. PD23] to [Pr. PD26], and [Pr. PD28].
- DI2 and DI3 are assigned to the CN1-10 and CN1-35 pins by default. When connecting a manual pulse generator, change them with [Pr. PD44] and [Pr. PD46]. Refer to section 9.1 for details of the manual pulse generator.
- Supply + of 24 DC V to OPC (Power input for open-collector sink interface) when input devices are assigned to the CN1-10 pin and the CN-35 pin. They cannot be used with source input interface. For the positioning mode, input devices (DI2 and DI3) are assigned with the initial values.
- Supply 24 V DC \pm 10% to interfaces of the MR-D01 from outside. The total current capacity of these power supplies must be 800 mA or lower. 800 mA is the value applicable when all I/O signals are used. The current capacity can be decreased by reducing the number of I/O points. For the current required for the interface, refer to section 3.8.2 (1) of "MR-J4-_A_(-RJ) Servo Amplifier Instruction Manual".
- As the 24 V DC for the input/output signals, one 24 V DC power supply can be used to supply to the servo amplifier and MR-D01. In this case, select an appropriate power supply capacity depending on the number of points of the input/output signals to be used.
- The CN1-2 pin and CN20-2 pin are exclusive. The CN1-2 pin is set by default. Select this item with [Pr. Po11].
- The CN1-27 pin and CN20-12 pin are exclusive. The CN1-27 pin is set by default. Select this item with [Pr. Po11].
- OTLA will be available when TL (External torque limit selection) is enabled with [Pr. Po02] to [Pr. Po07]. (Refer to section 11.5.3 (6).)
- The devices can be changed by [Pr. Po02] to [Pr. Po07].
- When using position data input 3 and position data input 4 with a source input interface, configure the circuit as shown in the figure.

11. MR-D01 EXTENSION I/O UNIT

2) Source I/O interface

POINT
● For notes, refer to (2) (b) 1) of this section.

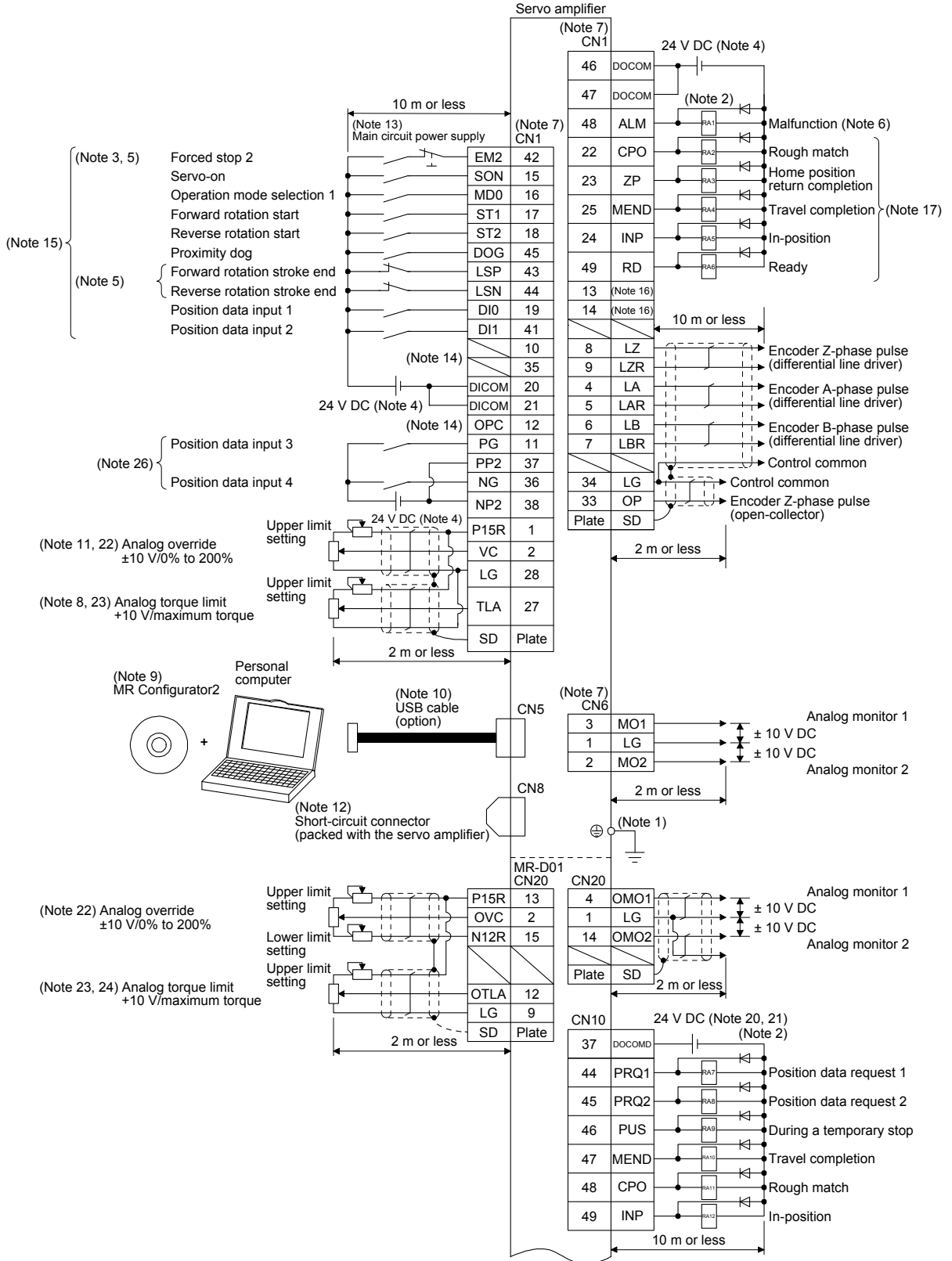

11. MR-D01 EXTENSION I/O UNIT

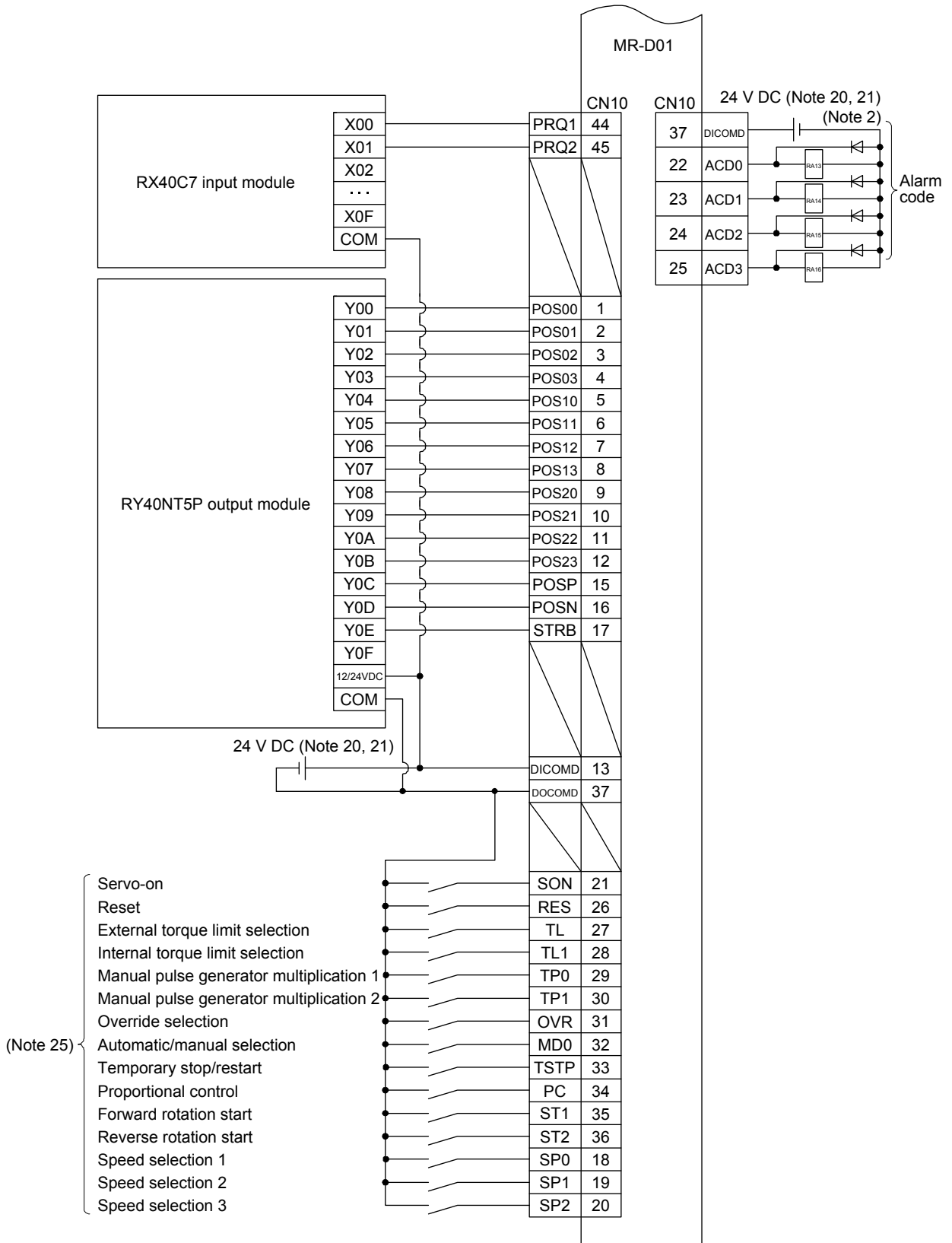

11. MR-D01 EXTENSION I/O UNIT

(3) Program method

POINT
<ul style="list-style-type: none"> Assign the following output devices to CN1-22, CN1-23, and CN1-25 pins with [Pr. PD23], [Pr. PD24], and [Pr. PD26]. CN1-22: CPO (Rough match) CN1-23: ZP (Home position return completion) CN1-25: MEND (Travel completion)

(a) Sink I/O interface

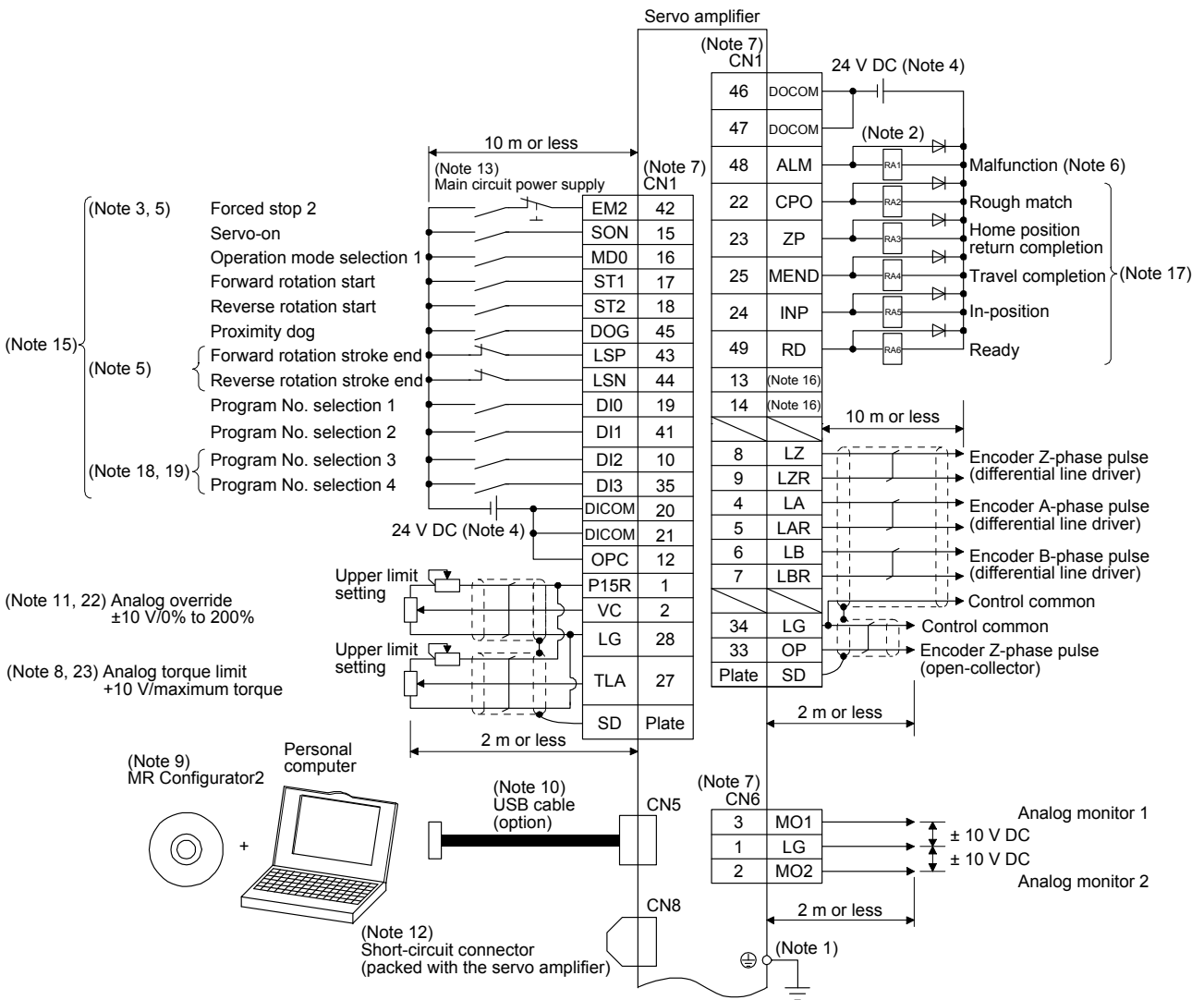

11. MR-D01 EXTENSION I/O UNIT

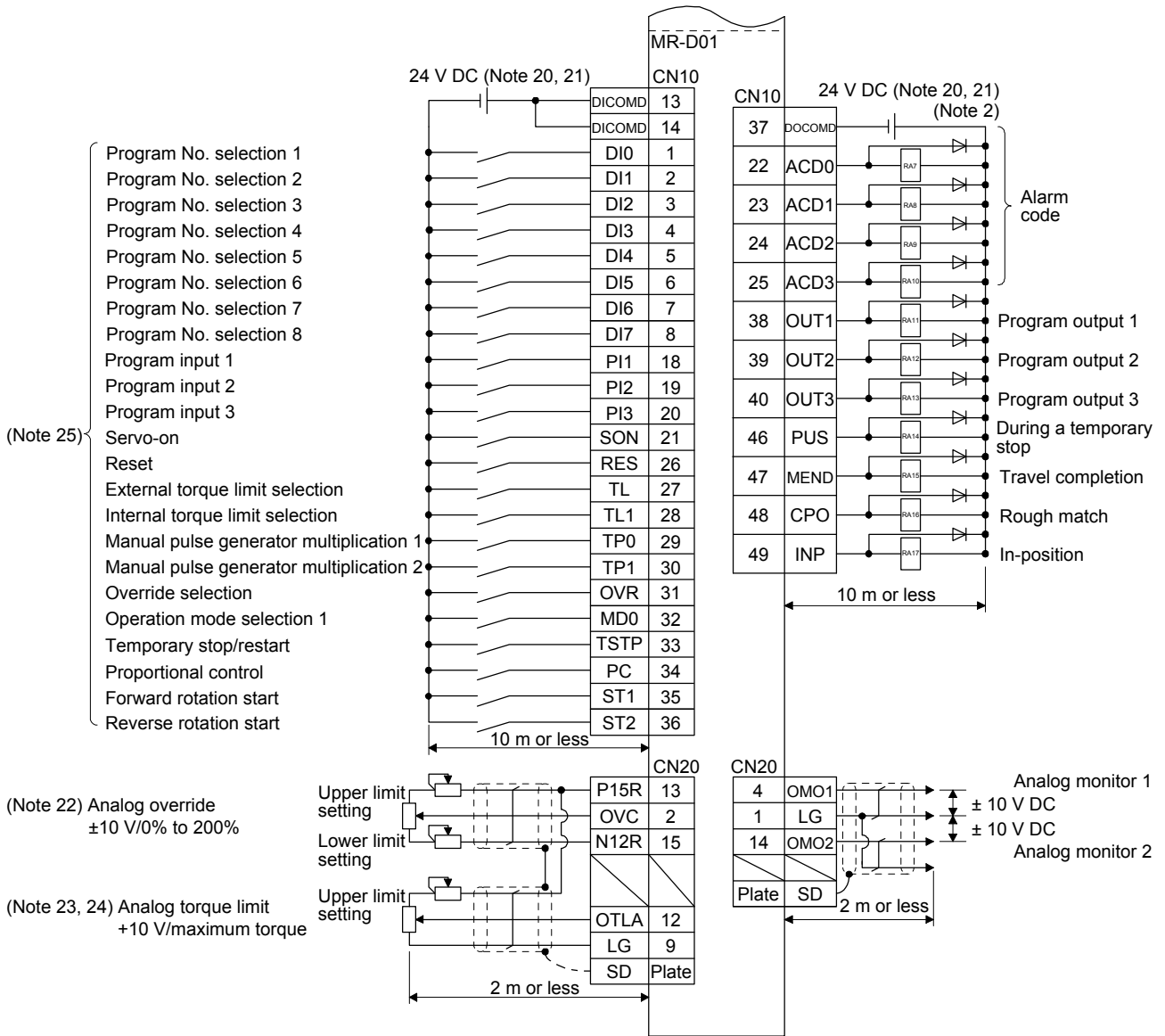

11. MR-D01 EXTENSION I/O UNIT

- Note
- To prevent an electric shock, always connect the protective earth (PE) terminal (marked \oplus) of the servo amplifier to the protective earth (PE) of the cabinet.
 - Connect the diode in the correct direction. If it is connected reversely, the servo amplifier will malfunction and will not output signals, disabling EM2 (Forced stop 2) and other protective circuits.
 - The forced stop switch (normally closed contact) must be installed.
 - Supply 24 V DC \pm 10% to interfaces from outside. The total current capacity of these power supplies must be 500 mA or lower. 500 mA is the value applicable when all I/O signals are used. The current capacity can be decreased by reducing the number of I/O points. Refer to section 3.9.2 (1) of "MR-J4- _A_(-RJ) Servo Amplifier Instruction Manual" that gives the current value necessary for the interface. A 24 V DC power supply can be used for both input signal and output signal.
 - When starting operation, always turn on EM2 (Forced stop 2), LSP (Forward rotation stroke end) and LSN (Reverse rotation stroke end). (Normally closed contact)
 - ALM (Malfunction) turns on in normal alarm-free condition. (Normally closed contact)
 - The pins with the same signal name are connected in the servo amplifier.
 - TLA will be available when TL (External torque limit selection) is enabled with [Pr. PD04], [Pr. PD06], [Pr. PD08], [Pr. PD10], [Pr. PD12], [Pr. PD14], [Pr. PD18], [Pr. PD20], [Pr. PD22], [Pr. PD44], and [Pr. PD46]. (Refer to section 3.6.1 (5) of "MR-J4- _A_(-RJ) Servo Amplifier Instruction Manual".)
 - Use SW1DNC MRC2-_. (Refer to "MR-J4- _A_(-RJ) Servo Amplifier Instruction Manual" section 11.7.)
 - Controllers or parameter units can also be connected via the CN3 connector with the RS-422/RS-485 communication. Note that using the USB communication function (CN5 connector) prevents the RS-422/RS-485 communication function (CN3 connector) from being used, and vice versa. They cannot be used together.

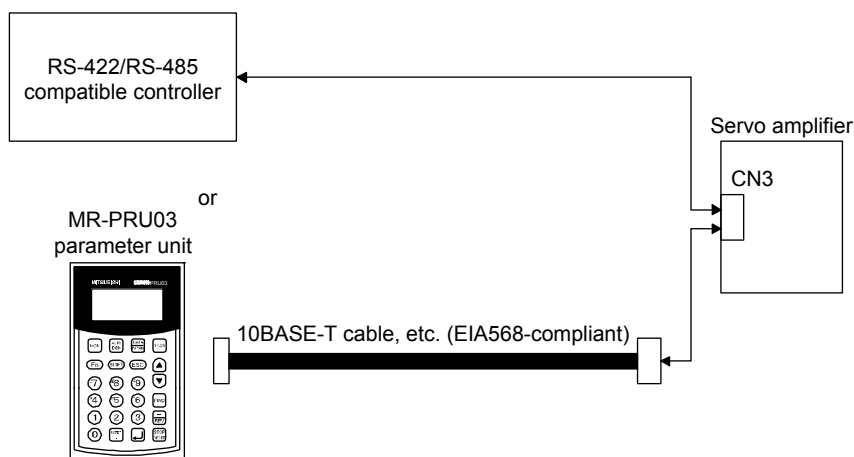

- Use an external power supply when inputting a negative voltage.
- When not using the STO function, attach the short-circuit connector came with a servo amplifier.
- Configure a circuit to turn off EM2 when the main circuit power is turned off to prevent an unexpected restart of the servo amplifier.
- The CN1-10 pin, CN1-12 pin, and CN1-35 pin cannot be used with source input interfaces.
- The devices can be changed with [Pr. PD04], [Pr. PD06], [Pr. PD08], [Pr. PD10], [Pr. PD12], [Pr. PD14], [Pr. PD18], [Pr. PD20], [Pr. PD22], [Pr. PD44], and [Pr. PD46].
- Output devices are not assigned by default. Assign the output devices with [Pr. PD47] as necessary.
- Recommended device assignments are shown. The devices can be changed by [Pr. PD23] to [Pr. PD26], and [Pr. PD28].
- DI2 and DI3 are assigned to the CN1-10 and CN1-35 pins by default. When connecting a manual pulse generator, change them with [Pr. PD44] and [Pr. PD46]. Refer to section 9.1 for details of the manual pulse generator.
- Supply + of 24 DC V to OPC (Power input for open-collector sink interface) when input devices are assigned to the CN1-10 pin and the CN-35 pin. They cannot be used with source input interface. For the positioning mode, input devices (DI2 and DI3) are assigned with the initial values.
- Supply 24 V DC \pm 10% to interfaces of the MR-D01 from outside. The total current capacity of these power supplies must be 800 mA or lower. 800 mA is the value applicable when all I/O signals are used. The current capacity can be decreased by reducing the number of I/O points. For the current required for the interface, refer to section 3.8.2 (1) of "MR-J4- _A_(-RJ) Servo Amplifier Instruction Manual".
- As the 24 V DC for the input/output signals, one 24 V DC power supply can be used to supply to the servo amplifier and MR-D01. In this case, select an appropriate power supply capacity depending on the number of points of the input/output signals to be used.
- The CN1-2 pin and CN20-2 pin are exclusive. The CN1-2 pin is set by default. Select this item with [Pr. Po11].
- The CN1-27 pin and CN20-12 pin are exclusive. The CN1-27 pin is set by default. Select this item with [Pr. Po11].
- When using program No. selection 3 and program No. selection 4 with a source input interface, configure the circuit as shown in the figure.

11. MR-D01 EXTENSION I/O UNIT

(b) Source I/O interface

POINT
 ● For notes, refer to (3) (a) of this section.

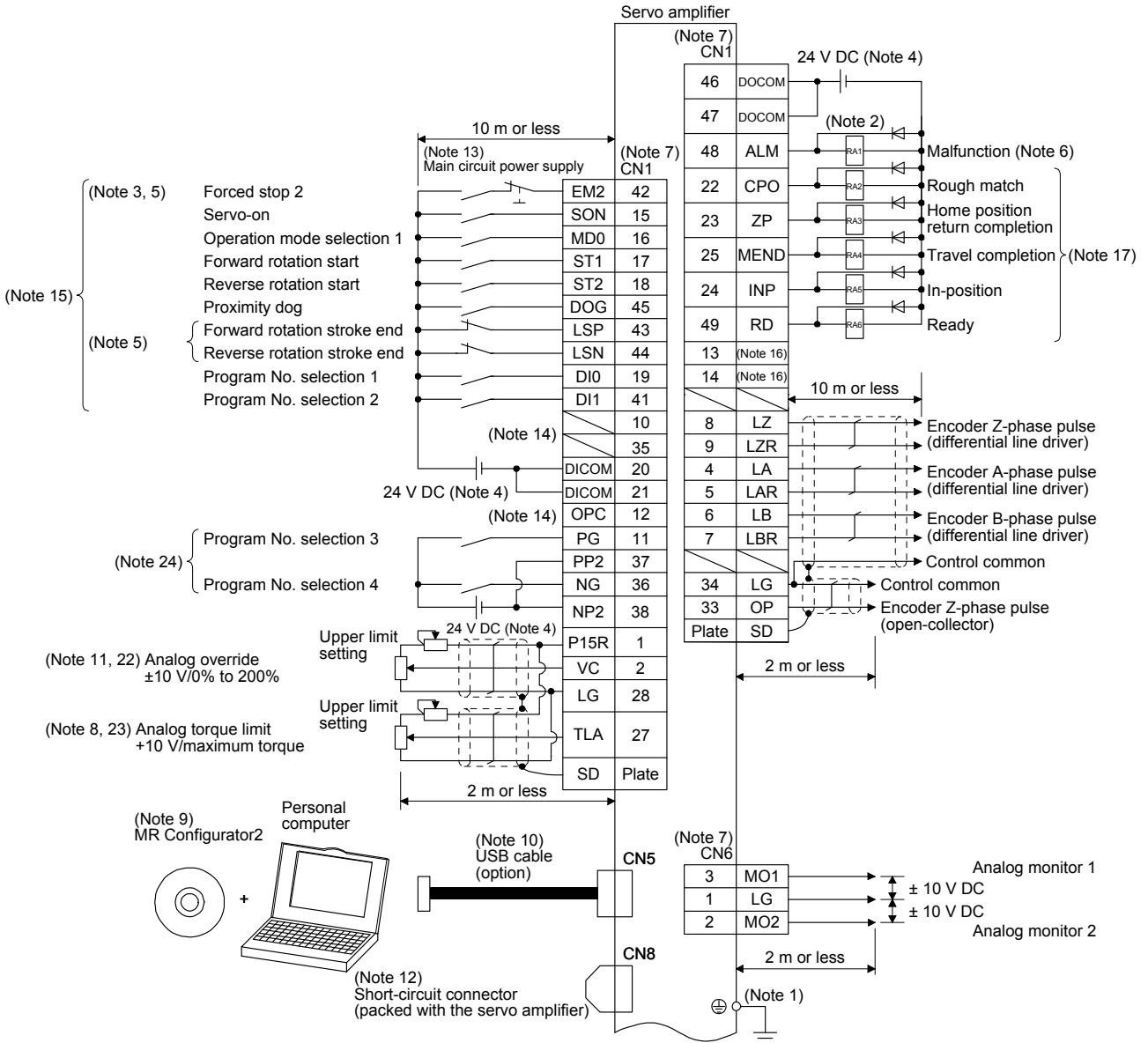

11. MR-D01 EXTENSION I/O UNIT

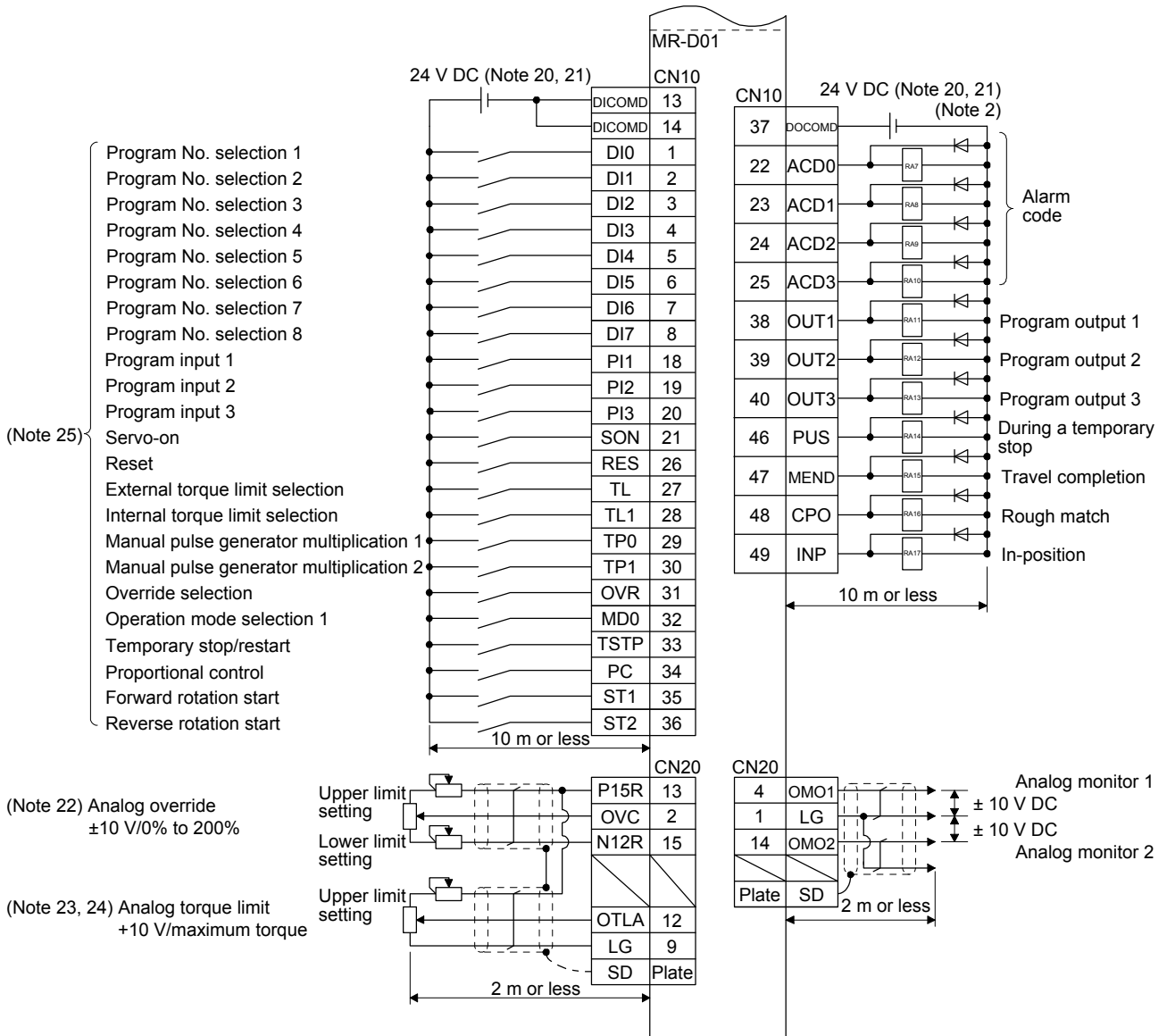

11. MR-D01 EXTENSION I/O UNIT

(4) Indexer method

POINT
<ul style="list-style-type: none"> ● Use MD1 (Operation mode selection 2) in the indexer method. When using MD1 with the servo amplifier, assign MD1 (Operation mode selection 2) to the CN1-18 pin with [Pr. PD10]. When using MD1 with the MR-D01, assign MD1 (Operation mode selection 2) to the CN10-36 pin with [Pr. Po07]. ● Assign the following output devices to CN1-22, CN1-23, and CN1-25 pins with [Pr. PD23], [Pr. PD24], and [Pr. PD26]. CN1-22: CPO (Rough match) CN1-23: ZP (Home position return completion) CN1-25: MEND (Travel completion)

(a) Sink I/O interface

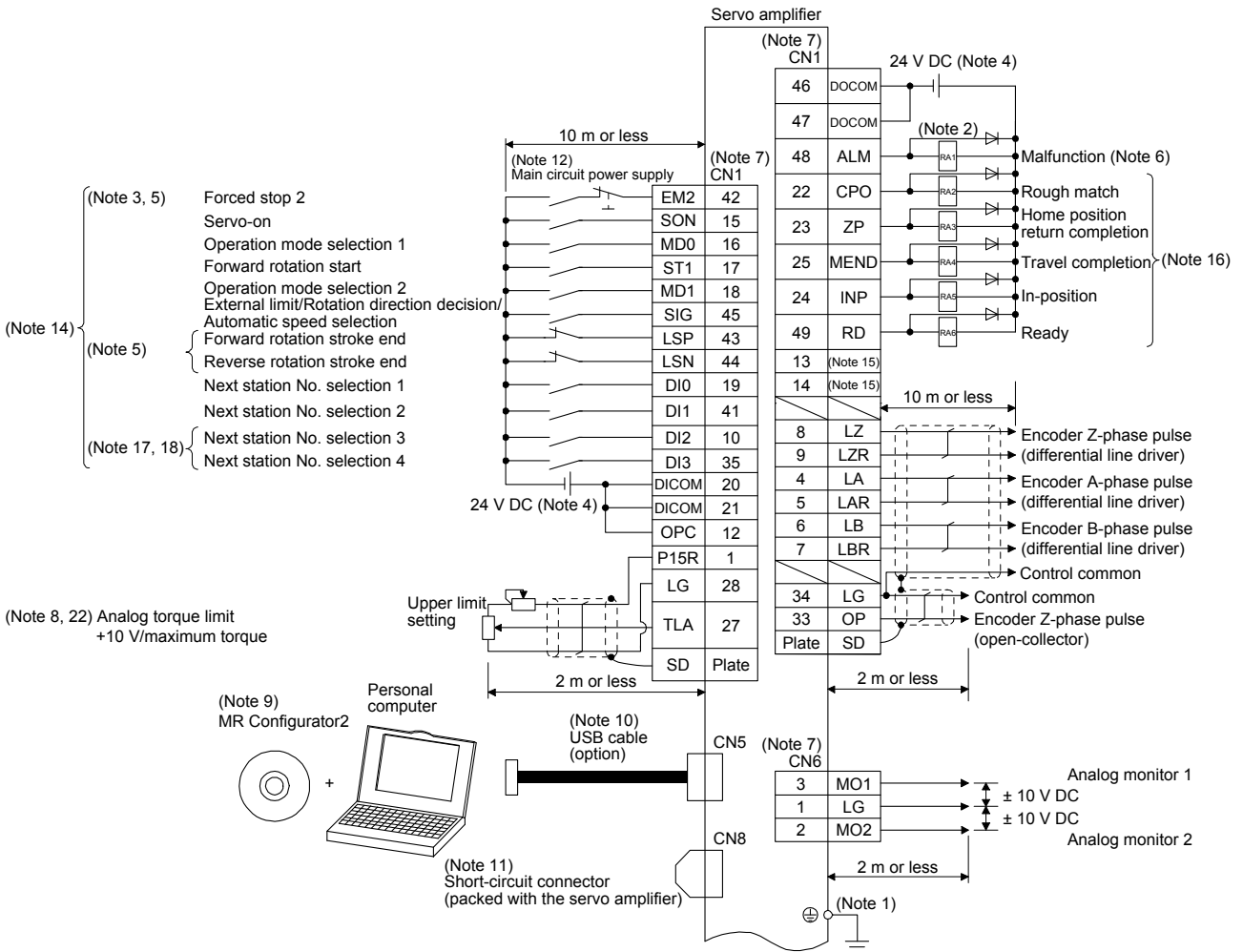

11. MR-D01 EXTENSION I/O UNIT

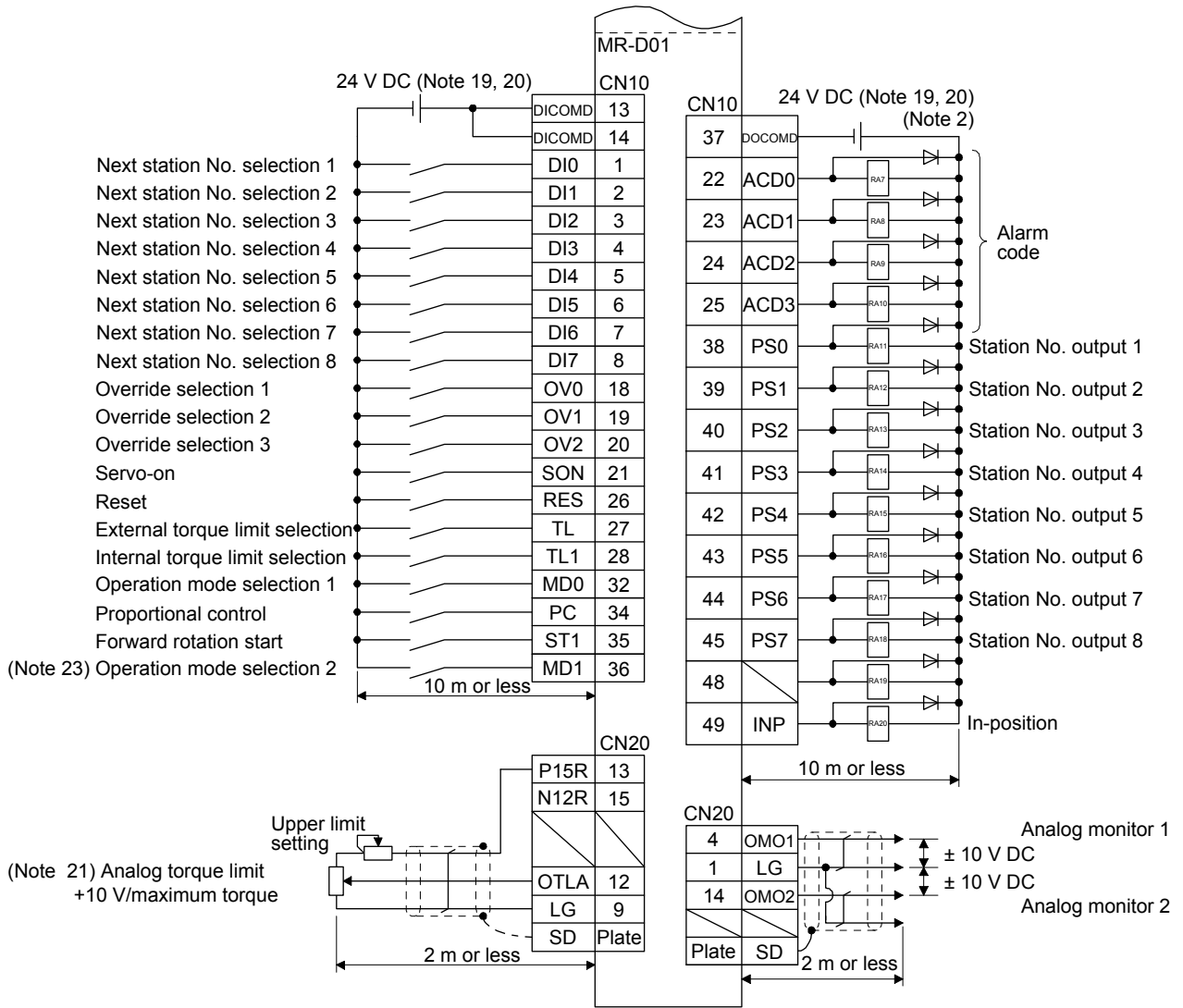

11. MR-D01 EXTENSION I/O UNIT

- Note
- To prevent an electric shock, always connect the protective earth (PE) terminal (marked \oplus) of the servo amplifier to the protective earth (PE) of the cabinet.
 - Connect the diode in the correct direction. If it is connected reversely, the servo amplifier will malfunction and will not output signals, disabling EM2 (Forced stop 2) and other protective circuits.
 - The forced stop switch (normally closed contact) must be installed.
 - Supply 24 V DC \pm 10% to interfaces from outside. The total current capacity of these power supplies must be 500 mA or lower. 500 mA is the value applicable when all I/O signals are used. The current capacity can be decreased by reducing the number of I/O points. Refer to section 3.9.2 (1) of "MR-J4- _A_ (-RJ) Servo Amplifier Instruction Manual" that gives the current value necessary for the interface. A 24 V DC power supply can be used for both input signal and output signal.
 - When starting operation, always turn on EM2 (Forced stop 2), LSP (Forward rotation stroke end) and LSN (Reverse rotation stroke end). (Normally closed contact)
 - ALM (Malfunction) turns on in normal alarm-free condition. (Normally closed contact)
 - The pins with the same signal name are connected in the servo amplifier.
 - TLA will be available when TL (External torque limit selection) is enabled with [Pr. PD04], [Pr. PD06], [Pr. PD08], [Pr. PD10], [Pr. PD12], [Pr. PD14], [Pr. PD18], [Pr. PD20], [Pr. PD22], [Pr. PD44], and [Pr. PD46]. (Refer to section 3.6.1 (5) of "MR-J4- _A_ (-RJ) Servo Amplifier Instruction Manual".)
 - Use SW1DNC MRC2-_. (Refer to "MR-J4- _A_ (-RJ) Servo Amplifier Instruction Manual" section 11.7.)
 - Controllers or parameter units can also be connected via the CN3 connector with the RS-422/RS-485 communication. Note that using the USB communication function (CN5 connector) prevents the RS-422/RS-485 communication function (CN3 connector) from being used, and vice versa. They cannot be used together.

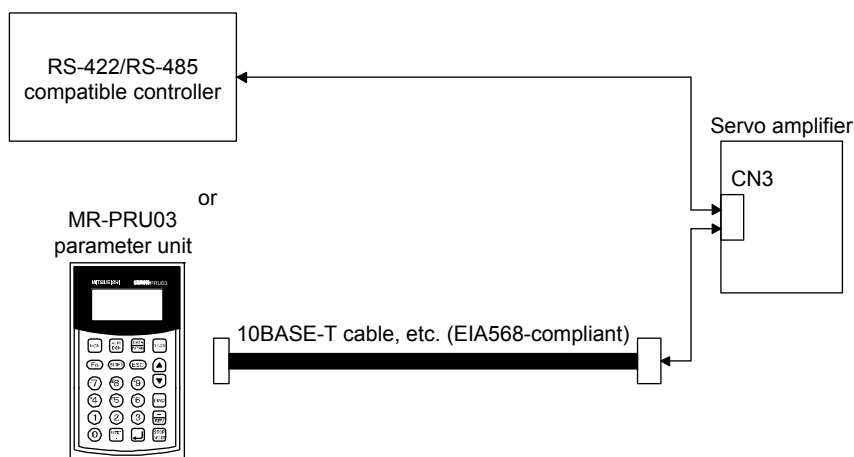

- When not using the STO function, attach the short-circuit connector came with a servo amplifier.
- Configure a circuit to turn off EM2 when the main circuit power is turned off to prevent an unexpected restart of the servo amplifier.
- This diagram shows sink I/O interface.
- The CN1-10 pin, CN1-12 pin, and CN1-35 pin cannot be used with source input interfaces.
- Output devices are not assigned by default. Assign the output devices with [Pr. PD47] as necessary.
- Recommended device assignments are shown. The devices can be changed by [Pr. PD23] to [Pr. PD26], and [Pr. PD28].
- DI2 and DI3 are assigned to the CN1-10 and CN1-35 pins by default. When connecting a manual pulse generator, change them with [Pr. PD44] and [Pr. PD46]. Refer to section 9.1 for details of the manual pulse generator.
- Supply + of 24 DC V to OPC (Power input for open-collector sink interface) when input devices are assigned to the CN1-10 pin and the CN-35 pin. They cannot be used with source input interface. For the positioning mode, input devices (DI2 and DI3) are assigned with the initial values.
- Supply 24 V DC \pm 10% to interfaces of the MR-D01 from outside. The total current capacity of these power supplies must be 800 mA or lower. 800 mA is the value applicable when all I/O signals are used. The current capacity can be decreased by reducing the number of I/O points. For the current required for the interface, refer to section 3.8.2 (1) of "MR-J4- _A_ (-RJ) Servo Amplifier Instruction Manual".
- As the 24 V DC for the input/output signals, one 24 V DC power supply can be used to supply to the servo amplifier and MR-D01. In this case, select an appropriate power supply capacity depending on the number of points of the input/output signals to be used.
- The CN1-27 pin and CN20-12 pin are exclusive. The CN1-27 pin is set by default. Select with [Pr. Po11].
- When using Operation mode selection 2 (MD1) in the unit, change [Pr. PD10] to "2108" to assign Operation mode selection 2 (MD1) to the CN1-18 pin in advance.
- When using next station No. selection 3 and next station No. selection 4 with a source input interface, configure the circuit as shown in the figure.

11. MR-D01 EXTENSION I/O UNIT

(b) Source I/O interface

POINT
● For notes, refer to (4) (a) of this section.

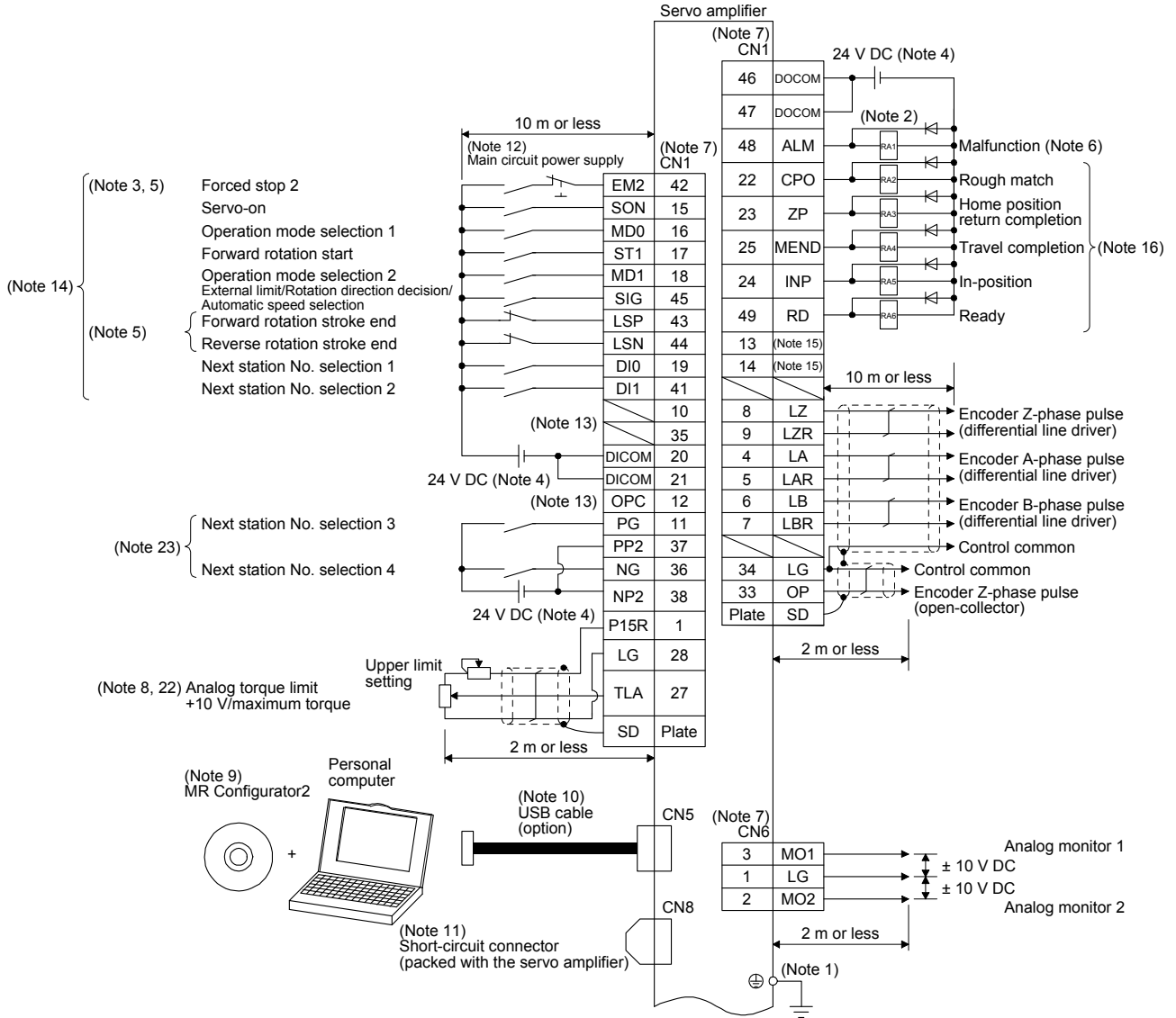

11. MR-D01 EXTENSION I/O UNIT

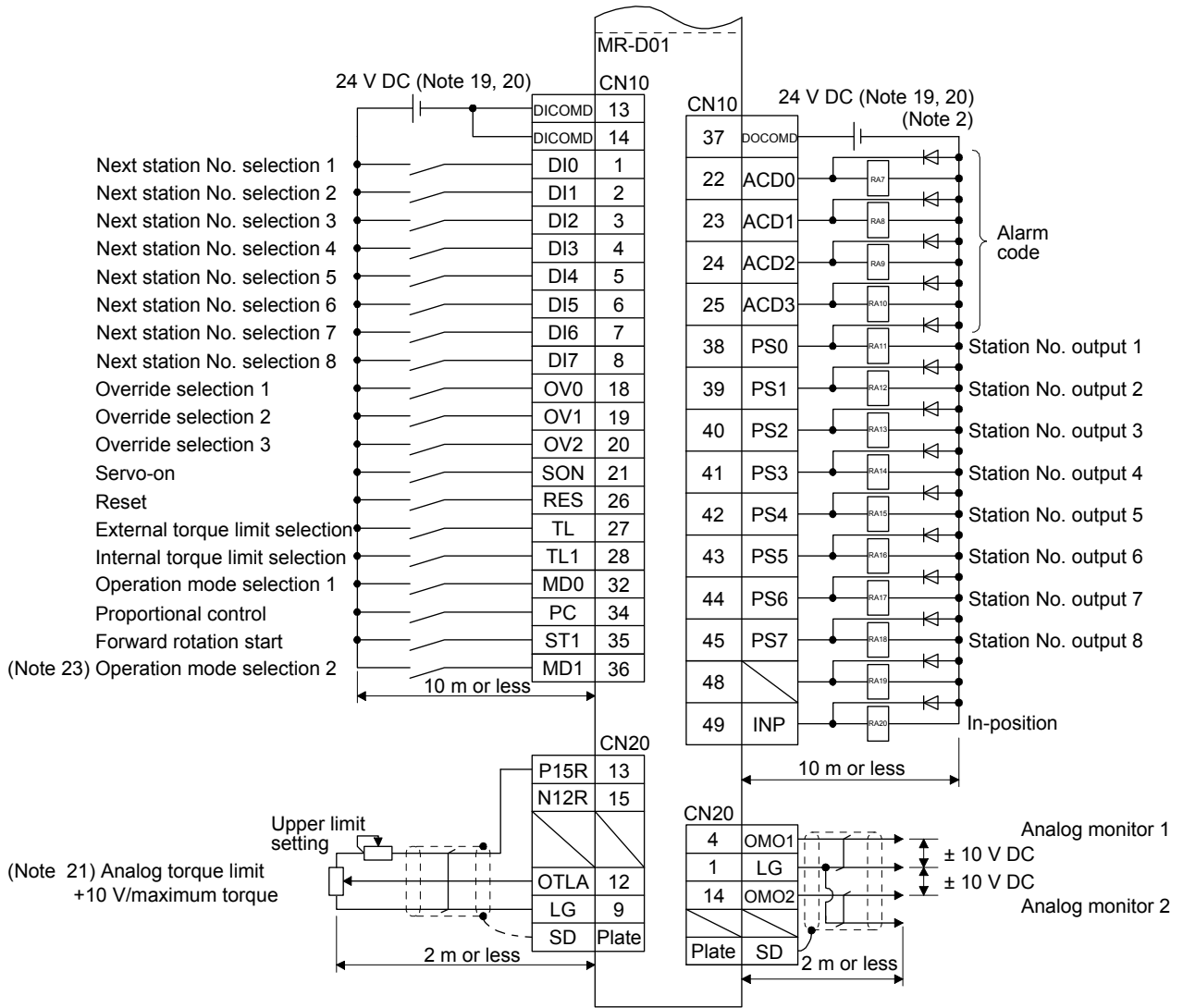

11. MR-D01 EXTENSION I/O UNIT

11.5.2 Connectors and pin assignment

POINT
<ul style="list-style-type: none"> ● The pin assignment of the connectors is as viewed from the cable connector wiring section. ● The CN30 connector is for manufacturer setting. This connector is attached on the MR-D01 servo amplifier, but not for use. ● For the pin assignment of the CN10 connector, refer to (2) in this section.

For details of each signal (device), refer to section 11.5.3.

(1) Pin assignment

The following is the front view of MR-J4-10A-RJ or MR-D01.

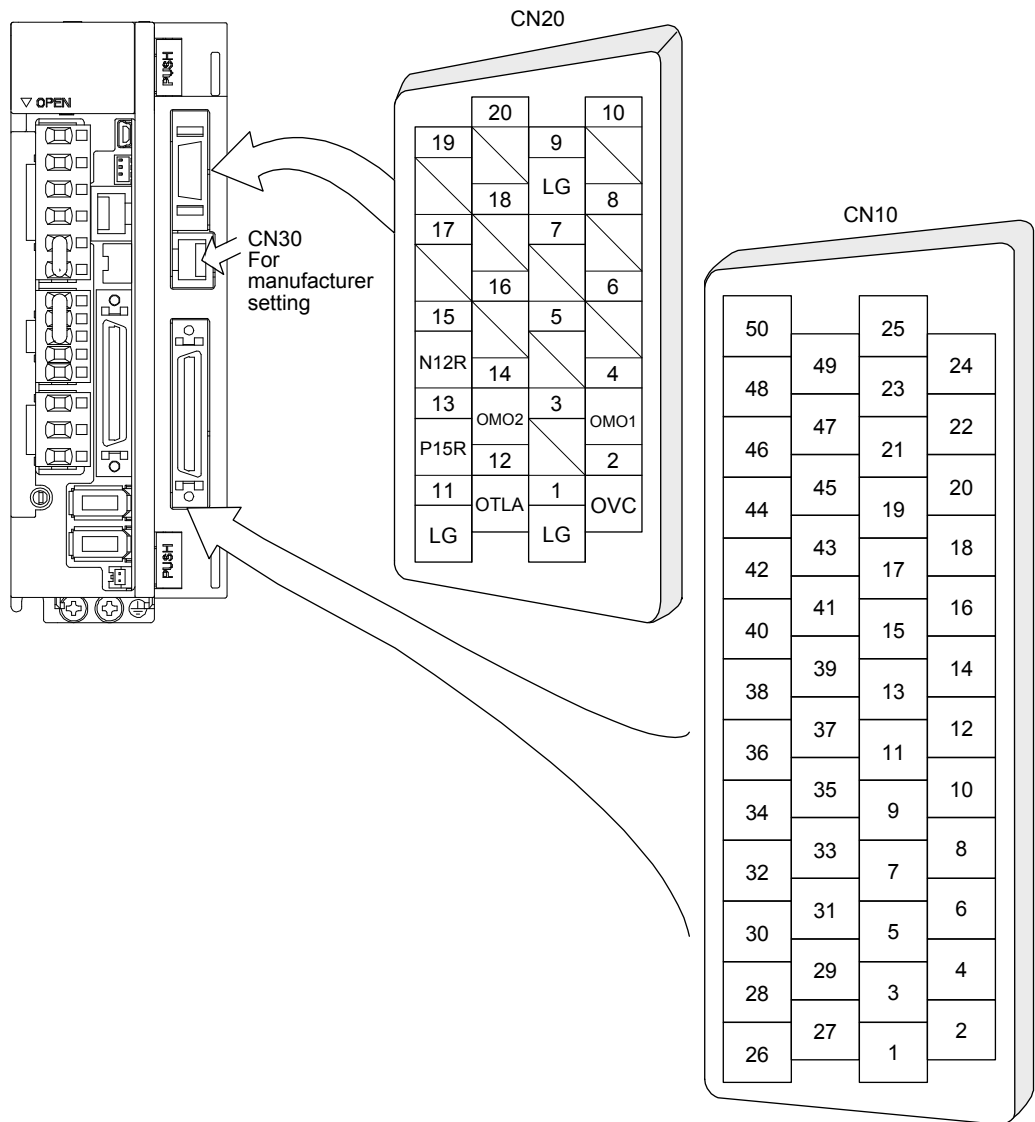

For the pin assignment, refer to (2) of this section.

11. MR-D01 EXTENSION I/O UNIT

(2) Pin assignment of the CN10 connector

Pin No.	(Note 1) I/O	(Note 2) I/O signals in control modes				Related parameter
		CP	BCD	CL	PS	
1	I	DI0	POS00	DI0	DI0	
2	I	DI1	POS01	DI1	DI1	
3	I	DI2	POS02	DI2	DI2	
4	I	DI3	POS03	DI3	DI3	
5	I	DI4	POS10	DI4	DI4	
6	I	DI5	POS11	DI5	DI5	
7	I	DI6	POS12	DI6	DI6	
8	I	DI7	POS13	DI7	DI7	
9	I		POS20			
10	I		POS21			
11	I		POS22			
12	I		POS23			
13		DICOMD	DICOMD	DICOMD	DICOMD	
14		DICOMD	DICOMD	DICOMD	DICOMD	
15	I		POSP			
16	I		POSN			
17	I		STRB			
18	I		SPD1			Pr. Po27
19	I		SPD2			Pr. Po27
20	I		SPD3			Pr. Po28
21	I	SON	SON	SON	SON	Pr. Po02
22	O	ACD0	ACD0	ACD0	ACD0	
23	O	ACD1	ACD1	ACD1	ACD1	
24	O	ACD2	ACD2	ACD2	ACD2	
25	O	ACD3	ACD3	ACD3	ACD3	
26	I	RES	RES	RES	RES	Pr. Po02
27	I	TL	TL	TL	TL	Pr. Po03
28	I	TL1	TL1	TL1	TL1	Pr. Po03
29	I	TP0	TP0	TP0		Pr. Po04
30	I	TP1	TP1	TP1		Pr. Po04
31	I	OVR	OVR	OVR		Pr. Po05
32	I	MD0	MD0	MD0	MD0	Pr. Po05
33	I	TSTP	TSTP	TSTP		Pr. Po06
34	I	PC	PC	PC	PC	Pr. Po06
35	I	ST1	ST1	ST1	ST1	Pr. Po07
36	I	ST2	ST2	ST2	MD1	Pr. Po07
37		DOCOMD	DOCOMD	DOCOMD	DOCOMD	
38	O	MCD00		OUT1	PS0	
39	O	MCD01		OUT2	PS1	
40	O	MCD02		OUT3	PS2	
41	O	MCD03			PS3	
42	O	MCD10			PS4	
43	O	MCD11			PS5	
44	O	MCD12	PRQ1		PS6	
45	O	MCD13	PRQ2		PS7	
46	O	PUS	PUS	PUS		Pr. Po08
47	O	MEND	MEND	MEND	MEND	Pr. Po08
48	O	CPO	CPO	CPO	CPO	Pr. Po09
49	O	INP	INP	INP	INP	Pr. Po09
50		SD	SD	SD	SD	

- Note 1. I: Input signal, O: Output signal
 2. CP: Positioning mode (point table method)
 BCD: Positioning mode (point table method in the BCD input positioning operation)
 CL: Positioning mode (program method)
 PS: Positioning mode (indexer method)

11. MR-D01 EXTENSION I/O UNIT

11.5.3 Signal (device) explanations

This section describes the signals (devices) of the MR-D01 extension I/O unit.

The connector pin No. column in the table lists the pin Nos. which devices are assigned to by default.

For the I/O interfaces (symbols in the I/O division column in the table), refer to section 11.5.4 (2). The symbols in the control mode field of the table shows the followings.

CP: Positioning mode (point table method)

BCD: Positioning mode (point table method in the BCD input positioning operation)

CL: Positioning mode (program method)

PS: Positioning mode (indexer method)

"○" and "△" of the table shows the followings.

○: Usable device by default.

△: Usable device by setting the following parameters.

[Pr. Po02] to [Pr. Po09], [Pr. Po27], and [Pr. Po28]

11. MR-D01 EXTENSION I/O UNIT

(1) I/O device

(a) Input device

Device	Symbol	Connector pin No.	Function and application	I/O division	Control mode																				
					\bar{A} C	B C	\bar{C} C	\bar{S} R																	
Servo-on	SON	CN10-21	Same as the one of when used with only a servo amplifier. Refer to section 2.3 (1) (a).	DI-1	○	○	○	○																	
Reset	RES	CN10-26		DI-1	○	○	○	○																	
Forward rotation stroke end	LSP			DI-1	△	△	△	△																	
Reverse rotation stroke end	LSN																								
External torque limit selection	TL	CN10-27		DI-1	○	○	○	○																	
Internal torque limit selection	TL1	CN10-28		DI-1	○	○	○	○																	
Operation mode selection 1	MD0	CN10-32	<p>Point table method/program method</p> <p>Turning on MD0 will be automatic operation mode, off will be manual operation mode. Changing an operation mode during operation will clear the command remaining distance and the motor will decelerate to stop.</p> <p>MD1 cannot be used.</p> <p>Indexer method</p> <p>Select an operation mode with combinations of MD0 and MD1. Refer to the following table for combinations.</p> <p>Changing an operation mode during operation will clear the command remaining distance and the motor will decelerate to stop.</p> <table border="1" style="margin-left: auto; margin-right: auto;"> <thead> <tr> <th colspan="2">Device (Note)</th> <th rowspan="2">Operation mode</th> </tr> <tr> <th>MD1</th> <th>MD0</th> </tr> </thead> <tbody> <tr> <td>0</td> <td>0</td> <td>Home position return mode</td> </tr> <tr> <td>0</td> <td>1</td> <td>Manual operation mode</td> </tr> <tr> <td>1</td> <td>0</td> <td>Automatic operation mode 1 (rotation direction specifying indexer)</td> </tr> <tr> <td>1</td> <td>1</td> <td>Automatic operation mode 2 (shortest rotating indexer)</td> </tr> </tbody> </table> <p>Note. 0: Off 1: On</p>	Device (Note)		Operation mode	MD1	MD0	0	0	Home position return mode	0	1	Manual operation mode	1	0	Automatic operation mode 1 (rotation direction specifying indexer)	1	1	Automatic operation mode 2 (shortest rotating indexer)	DI-1	○	○	○	○
Device (Note)		Operation mode																							
MD1	MD0																								
0	0	Home position return mode																							
0	1	Manual operation mode																							
1	0	Automatic operation mode 1 (rotation direction specifying indexer)																							
1	1	Automatic operation mode 2 (shortest rotating indexer)																							
Operation mode selection 2	MD1		DI-1				△																		

11. MR-D01 EXTENSION I/O UNIT

Device	Symbol	Connector pin No.	Function and application	I/O division	Control mode			
					$\frac{P}{C}$	BCD	$\frac{J}{L}$	$\frac{S}{R}$
Forward rotation start	ST1	CN10-35	Same as the one of when used with only a servo amplifier. Refer to section 2.3 (1) (a).	DI-1	○	○	○	○
Reverse rotation start	ST2	CN10-36		DI-1	○	○	○	△
Temporary stop/restart	TSTP	CN10-33		DI-1	○	○	○	△
Proximity dog	DOG	△		DI-1	△	△	△	△
External limit/Rotation direction decision/Automatic speed selection	SIG	△		DI-1	△	△	△	△
Manual pulse generator multiplication 1	TP0	CN10-29		DI-1	○	○	○	△
Manual pulse generator multiplication 2	TP1	CN10-30		DI-1	○	○	○	△
Analog override selection	OVR	CN10-31		DI-1	○	○	○	△
Teach	TCH	△		DI-1	△	△	△	△
Program input 1	PI1	△		DI-1	△	△	△	△
Program input 2	PI2	△		DI-1	△	△	△	△
Program input 3	PI3	△		DI-1	△	△	△	△
Current position latch input	LPS	△		DI-1	△	△	△	△
Point table No. 1/Program No. selection 1/Next station No. selection 1	DI0	CN10-1		DI-1	○	○	○	○
Point table No. 2/Program No. selection 2/Next station No. selection 2	DI1	CN10-2		DI-1	○	○	○	○
Point table No. 3/Program No. selection 3/Next station No. selection 3	DI2	CN10-3		DI-1	○	○	○	○
Point table No. 4/Program No. selection 4/Next station No. selection 4	DI3	CN10-4		DI-1	○	○	○	○
Point table No. 5/Program No. selection 5/Next station No. selection 5	DI4	CN10-5		DI-1	○	○	○	○
Point table No. 6/Program No. selection 6/Next station No. selection 6	DI5	CN10-6		DI-1	○	○	○	○

11. MR-D01 EXTENSION I/O UNIT

Device	Symbol	Connector pin No.	Function and application	I/O division	Control mode			
					P C	BCD	U L	S R
Point table No. 7/Program No. selection 7/Next station No. selection 7	DI6	CN10-7	Same as the one of when used with only a servo amplifier. Refer to section 2.3 (1) (a).	DI-1	○	○	○	○
Point table No. 8/Program No. selection 8/Next station No. selection 8	DI7	CN10-8		DI-1	○	○	○	○

11. MR-D01 EXTENSION I/O UNIT

Device	Symbol	Connector pin No.	Function and application	I/O division	Control mode																																																																														
					PLC	BCD	UL	SL																																																																											
Position data input 1 (1st/4th digit, bit 0)	POS00	CN10-1	<p>This device can be used when an MR-D01 has been connected. To use these signals, set [Pr. Po10] to "___2".</p> <p>Input the 6-digit (3-digit BCD × 2) position data with POS00 to POS03, POS10 to POS13, and POS20 to POS23.</p> <p>The code represents one digit of decimal using four digits of binary. The following shows correspondence of each digit and device.</p> <div style="text-align: center;"> <table border="0"> <tr> <td colspan="4">Third/sixth digit</td> <td colspan="4">Second/fifth digit</td> <td colspan="4">First/fourth digit</td> </tr> <tr> <td>bit3</td><td>bit2</td><td>bit1</td><td>bit0</td> <td>bit3</td><td>bit2</td><td>bit1</td><td>bit0</td> <td>bit3</td><td>bit2</td><td>bit1</td><td>bit0</td> </tr> <tr> <td colspan="4" rowspan="12"> </td> <td colspan="4">POS00</td> <td colspan="4">POS01</td> </tr> <tr> <td colspan="4">POS02</td> <td colspan="4">POS03</td> </tr> <tr> <td colspan="4">POS10</td> <td colspan="4">POS11</td> </tr> <tr> <td colspan="4">POS12</td> <td colspan="4">POS13</td> </tr> <tr> <td colspan="4">POS20</td> <td colspan="4">POS21</td> </tr> <tr> <td colspan="4">POS22</td> <td colspan="4">POS23</td> </tr> </table> </div>	Third/sixth digit				Second/fifth digit				First/fourth digit				bit3	bit2	bit1	bit0	bit3	bit2	bit1	bit0	bit3	bit2	bit1	bit0					POS00				POS01				POS02				POS03				POS10				POS11				POS12				POS13				POS20				POS21				POS22				POS23				DI-1	<input type="checkbox"/>	<input type="checkbox"/>	<input type="checkbox"/>
Third/sixth digit				Second/fifth digit				First/fourth digit																																																																											
bit3	bit2	bit1		bit0	bit3	bit2	bit1	bit0	bit3	bit2	bit1	bit0																																																																							
				POS00				POS01																																																																											
				POS02				POS03																																																																											
				POS10				POS11																																																																											
				POS12				POS13																																																																											
				POS20				POS21																																																																											
				POS22				POS23																																																																											
				Position data input 2 (1st/4th digit, bit 1)	POS01	CN10-2	DI-1	<input type="checkbox"/>	<input type="checkbox"/>	<input type="checkbox"/>	<input type="checkbox"/>																																																																								
				Position data input 3 (1st/4th digit, bit 2)	POS02	CN10-3	DI-1	<input type="checkbox"/>	<input type="checkbox"/>	<input type="checkbox"/>	<input type="checkbox"/>																																																																								
				Position data input 4 (1st/4th digit, bit 3)	POS03	CN10-4	DI-1	<input type="checkbox"/>	<input type="checkbox"/>	<input type="checkbox"/>	<input type="checkbox"/>																																																																								
				Position data input 5 (2nd/5th digit, bit 0)	POS10	CN10-5	DI-1	<input type="checkbox"/>	<input type="checkbox"/>	<input type="checkbox"/>	<input type="checkbox"/>																																																																								
				Position data input 6 (2nd/5th digit, bit 1)	POS11	CN10-6	DI-1	<input type="checkbox"/>	<input type="checkbox"/>	<input type="checkbox"/>	<input type="checkbox"/>																																																																								
				Position data input 7 (2nd/5th digit, bit 2)	POS12	CN10-7	DI-1	<input type="checkbox"/>	<input type="checkbox"/>	<input type="checkbox"/>	<input type="checkbox"/>																																																																								
Position data input 8 (2nd/5th digit, bit 3)	POS13	CN10-8	DI-1	<input type="checkbox"/>	<input type="checkbox"/>	<input type="checkbox"/>	<input type="checkbox"/>																																																																												
Position data input 9 (3rd/6th digit, bit 0)	POS20	CN10-9	DI-1	<input type="checkbox"/>	<input type="checkbox"/>	<input type="checkbox"/>	<input type="checkbox"/>																																																																												
Position data input 10 (3rd/6th digit, bit 1)	POS21	CN10-10	DI-1	<input type="checkbox"/>	<input type="checkbox"/>	<input type="checkbox"/>	<input type="checkbox"/>																																																																												
Position data input 11 (3rd/6th digit, bit 2)	POS22	CN10-11	DI-1	<input type="checkbox"/>	<input type="checkbox"/>	<input type="checkbox"/>	<input type="checkbox"/>																																																																												
Position data input 12 (3rd/6th digit, bit 3)	POS23	CN10-12	DI-1	<input type="checkbox"/>	<input type="checkbox"/>	<input type="checkbox"/>	<input type="checkbox"/>																																																																												

Device (Note 1)				Setting (decimal)
POS03 POS13 POS23	POS02 POS12 POS22	POS01 POS11 POS21	POS00 POS10 POS20	
0	0	0	0	0
0	0	0	1	1
0	0	1	0	2
0	0	1	1	3
0	1	0	0	4
0	1	0	1	5
0	1	1	0	6
0	1	1	1	7
1	0	0	0	8
1	0	0	1	9
1	0	1	0	Setting inhibited (Note 2)
1	0	1	1	
1	1	0	0	
1	1	0	1	
1	1	1	0	
1	1	1	1	

Note 1. 0: Off
1: On
2. If these devices are set, [AL. A9A.2 Optional unit input data error warning] occurs.

11. MR-D01 EXTENSION I/O UNIT

Device	Symbol	Connector pin No.	Function and application	I/O division	Control mode																																																			
					α	β	γ	δ																																																
Position data input sign +	POSP	CN10-15	Input + signs of 3-digit BCD × 2 inputs. If + and - signs are set at the same time or different signs are set to the 1st to 3rd digits and 4th digit to 6th digit, [AL. 9A.2 Optional unit input data error warning] occurs.	DI-1		○																																																		
Position data input sign -	POSN	CN10-16	Input - signs of 3-digit BCD × 2 inputs. If + and - signs are set at the same time or different signs are set to the 1st to 3rd digits and 4th digit to 6th digit, [AL. 9A.2 Optional unit input data error warning] occurs.	DI-1		○																																																		
Strobe input	STRB	CN10-17	This strobe signal is used when 3-digit BCD × 2 is input from a programmable controller.	DI-1		○																																																		
Speed selection 1	SPD1	CN10-18	This device can be used when an MR-D01 has been connected. To use these signals, set [Pr. Po10] to " __ _2". Select point tables and home position return mode with SPD1 to SPD4. The values of the rotation speed, acceleration/deceleration time constants, and deceleration time constant of the selected point table become speed commands in a positioning operation by 3-digit BCD × 2 inputs.	DI-1		○																																																		
Speed selection 2	SPD2	CN10-19		DI-1		○																																																		
Speed selection 3	SPD3	CN10-20		DI-1		○																																																		
Speed selection 4	SPD4			DI-1		△																																																		
			<table border="1"> <thead> <tr> <th colspan="4">Device (Note)</th> <th rowspan="2">Selection contents</th> </tr> <tr> <th>SPD4</th> <th>SPD3</th> <th>SPD2</th> <th>SPD1</th> </tr> </thead> <tbody> <tr> <td>0</td> <td>0</td> <td>0</td> <td>0</td> <td>Home position return mode</td> </tr> <tr> <td>0</td> <td>0</td> <td>0</td> <td>1</td> <td>Point table No. 1</td> </tr> <tr> <td>0</td> <td>0</td> <td>1</td> <td>0</td> <td>Point table No. 2</td> </tr> <tr> <td>.</td> <td>.</td> <td>.</td> <td>.</td> <td>.</td> </tr> <tr> <td>.</td> <td>.</td> <td>.</td> <td>.</td> <td>.</td> </tr> <tr> <td>.</td> <td>.</td> <td>.</td> <td>.</td> <td>.</td> </tr> <tr> <td>1</td> <td>1</td> <td>1</td> <td>0</td> <td>Point table No. 14</td> </tr> <tr> <td>1</td> <td>1</td> <td>1</td> <td>1</td> <td>Point table No. 15</td> </tr> </tbody> </table> <p>Note. 0: Off 1: On</p>	Device (Note)				Selection contents	SPD4	SPD3	SPD2	SPD1	0	0	0	0	Home position return mode	0	0	0	1	Point table No. 1	0	0	1	0	Point table No. 2	1	1	1	0	Point table No. 14	1	1	1	1	Point table No. 15				
Device (Note)				Selection contents																																																				
SPD4	SPD3	SPD2	SPD1																																																					
0	0	0	0	Home position return mode																																																				
0	0	0	1	Point table No. 1																																																				
0	0	1	0	Point table No. 2																																																				
.																																																				
.																																																				
.																																																				
1	1	1	0	Point table No. 14																																																				
1	1	1	1	Point table No. 15																																																				
Second acceleration/deceleration selection	RT		Same as the one of when used with only a servo amplifier. Refer to section 2.3 (1) (a).	DI-1				△																																																
Second acceleration/deceleration gain selection	RTCDP			DI-1				△																																																
Digital override selection 1	OV0			DI-1				△																																																
Digital override selection 2	OV1							△																																																
Digital override selection 3	OV2							△																																																
Digital override selection 4	OV3							△																																																
Mark detection	MSD			DI-1	△	△	△																																																	
Proportional control	PC	CN10-34		DI-1	○	○	○	○																																																
Clear	CR			DI-1	△	△	△	△																																																
Gain switching	CDP			DI-1	△	△	△	△																																																
Fully closed loop selection	CLD		DI-1																																																					
Motor-side/load-side deviation counter clear	MECR		DI-1	△	△	△																																																		

11. MR-D01 EXTENSION I/O UNIT

Device	Symbol	Connector pin No.	Function and application	I/O division	Control mode																																																																						
					△	△	△	△																																																																			
Cam control command	CAMC		When using CAMC, set [Pr. PT35] to "_ 1 _" to enable it. Turning CAMC on switches the control from the normal positioning control to the cam control.	DI-1	△	△	△																																																																				
Cam position compensation request	CPCD		Turning CPCD on compensates the cam axis one cycle current value to be in the position set in [Cam control data No. 60 - Cam position compensation target position].	DI-1	△	△	△																																																																				
Clutch command	CLTC		This is used to turning on/off the main shaft clutch command. This is used when [Cam control data No. 36 - Main shaft clutch control setting] is set to " _ _ _ 1".	DI-1	△	△	△																																																																				
Cam control command	CAMC		When using CAMC, set [Pr. PT35] to "_ 1 _" to enable it. Turning CAMC on switches the control from the normal positioning control to the cam control.	DI-1	△	△	△																																																																				
Cam No. selection 0	CI0		Select cam No. This is enabled when [Cam control data No. 49 - Cam No.] is set to "0".	DI-1	△	△	△																																																																				
Cam No. selection 1	CI1		<table border="1" style="width: 100%; border-collapse: collapse;"> <thead> <tr> <th colspan="4">Device (Note 1)</th> <th rowspan="2">Selection contents</th> </tr> <tr> <th>CI3</th> <th>CI2</th> <th>CI1</th> <th>CI0</th> </tr> </thead> <tbody> <tr> <td>0</td> <td>0</td> <td>0</td> <td>0</td> <td>Linear cam</td> </tr> <tr> <td>0</td> <td>0</td> <td>0</td> <td>1</td> <td>Cam No. 1</td> </tr> <tr> <td>0</td> <td>0</td> <td>1</td> <td>0</td> <td>Cam No. 2</td> </tr> <tr> <td>0</td> <td>0</td> <td>1</td> <td>1</td> <td>Cam No. 3</td> </tr> <tr> <td>.</td> <td>.</td> <td>.</td> <td>.</td> <td>.</td> </tr> <tr> <td>.</td> <td>.</td> <td>.</td> <td>.</td> <td>.</td> </tr> <tr> <td>.</td> <td>.</td> <td>.</td> <td>.</td> <td>.</td> </tr> <tr> <td>1</td> <td>0</td> <td>0</td> <td>0</td> <td>Cam No. 8</td> </tr> <tr> <td>1</td> <td>0</td> <td>0</td> <td>1</td> <td rowspan="3">Setting prohibited (Note 2)</td> </tr> <tr> <td>.</td> <td>.</td> <td>.</td> <td>.</td> </tr> <tr> <td>.</td> <td>.</td> <td>.</td> <td>.</td> </tr> <tr> <td>1</td> <td>1</td> <td>1</td> <td>1</td> <td></td> </tr> </tbody> </table>		Device (Note 1)				Selection contents	CI3	CI2	CI1	CI0	0	0	0	0	Linear cam	0	0	0	1	Cam No. 1	0	0	1	0	Cam No. 2	0	0	1	1	Cam No. 3	1	0	0	0	Cam No. 8	1	0	0	1	Setting prohibited (Note 2)	1	1	1	1		△	△	△	
Device (Note 1)					Selection contents																																																																						
CI3	CI2	CI1				CI0																																																																					
0	0	0			0	Linear cam																																																																					
0	0	0			1	Cam No. 1																																																																					
0	0	1			0	Cam No. 2																																																																					
0	0	1		1	Cam No. 3																																																																						
.																																																																							
.																																																																							
.																																																																							
1	0	0	0	Cam No. 8																																																																							
1	0	0	1	Setting prohibited (Note 2)																																																																							
.	.	.	.																																																																								
.	.	.	.																																																																								
1	1	1	1																																																																								
Cam No. selection 2	CI2			△	△	△																																																																					
Cam No. selection 3	CI3			△	△	△																																																																					

Note 1. 0: Off
 1: On
 2. [AL. F6.5 Cam No. external error] occurs.

11. MR-D01 EXTENSION I/O UNIT

(b) Output device

Device	Symbol	Connector pin No.	Function and application	I/O division	Control mode			
					□	□	□	□
Malfunction	ALM		Same as the one of when used with only a servo amplifier. Refer to section 2.3 (1) (b).	DO-1	△	△	△	△
Alarm/warning	ALM WNG			DO-1	△	△	△	△
Warning	WNG			DO-1	△	△	△	△
Battery warning	BWNG			DO-1	△	△	△	△
AL9F Warning	BW9F			DO-1	△	△	△	△
Dynamic brake interlock	DB			DO-1	△	△	△	△
Ready	RD			DO-1	△	△	△	△
In-position	INP			DO-1	△	△	△	△
Limiting torque	TLC			DO-1	△	△	△	△
Zero speed detection	ZSP			DO-1	△	△	△	△
Electromagnetic brake interlock	MBR			DO-1	△	△	△	△
Speed command reached	SA			DO-1	△	△	△	△
Home position return completion	ZP			DO-1	△	△	△	△
Rough match	CPO	CN10-48		DO-1	○	○	○	○
Position range output	POT			DO-1	△	△	△	△
During a temporary stop	PUS	CN10-46		DO-1	○	○	○	○
Travel completion	MEND			DO-1	△	△	△	△
Position end	PED			DO-1	△	△	△	△
SYNC synchronous output	SOUT	CN10-19		DO-1	△	△	△	△
Program output 1	OUT1	CN10-38		DO-1	△	△	△	△
Program output 2	OUT2	CN10-39	DO-1	△	△	△	△	
Program output 3	OUT3	CN10-40	DO-1	△	△	△	△	
Point table No. output 1	PT0		DO-1	△	△	△	△	
Point table No. output 2	PT1		DO-1	△	△	△	△	
Point table No. output 3	PT2		DO-1	△	△	△	△	
Point table No. output 4	PT3		DO-1	△	△	△	△	
Point table No. output 5	PT4		DO-1	△	△	△	△	
Point table No. output 6	PT5		DO-1	△	△	△	△	
Point table No. output 7	PT6		DO-1	△	△	△	△	
Point table No. output 8	PT7		DO-1	△	△	△	△	
Station output 1	PS0	CN10-38	DO-1	△	△	△	△	
Station output 2	PS1	CN10-39	DO-1	△	△	△	△	
Station output 3	PS2	CN10-40	DO-1	△	△	△	△	

11. MR-D01 EXTENSION I/O UNIT

Device	Symbol	Connector pin No.	Function and application	I/O division	Control mode			
					P C	BCD	CL	S P
Station output 4	PS3	CN10-41	Same as the one of when used with only a servo amplifier. Refer to section 2.3 (1) (b).	DO-1				○
Station output 5	PS4	CN10-42		DO-1				○
Station output 6	PS5	CN10-43		DO-1				○
Station output 7	PS6	CN10-44		DO-1				○
Station output 8	PS7	CN10-45		DO-1				○
M code 1 (bit 0)	MCD00	CN10-38		DO-1	○			
M code 2 (bit 1)	MCD01	CN10-39		DO-1	○			
M code 3 (bit 2)	MCD02	CN10-40		DO-1	○			
M code 4 (bit 3)	MCD03	CN10-41		DO-1	○			
M code 5 (bit 4)	MCD10	CN10-42		DO-1	○			
M code 6 (bit 5)	MCD11	CN10-43		DO-1	○			
M code 7 (bit 6)	MCD12	CN10-44		DO-1	○			
M code 8 (bit 7)	MCD13	CN10-45		DO-1	○			
Position data request 1	PRQ1	CN10-44	When signs and positioning data of 4th to 6th digits are required with 3-digit BCD × 2 inputs, PRQ1 turns on.	DO-1		△		
Position data request 2	PRQ2	CN10-45	When signs and positioning data of 1st to 3rd digits are required with 3-digit BCD × 2 inputs, PRQ2 turns on.	DO-1		△		
Mark detection rising latch completed	MSDH		Same as the one of when used with only a servo amplifier. Refer to section 2.3 (1) (b).	DO-1	△	△	△	
Mark detection falling latch completed	MSDL			DO-1	△	△	△	
Alarm code 0	ACD0	CN10-38 CN10-22	To use these signals, set [Pr. Po12] to "_ _ _ 1". In the indexer method, Alarm codes 0 to 3 are output to CN10-38 to CN10-41. For details of the alarm codes, refer to chapter 8.	DO-1	○	○	○	○
Alarm code 1	ACD1	CN10-39 CN10-23		DO-1	○	○	○	○
Alarm code 2	ACD2	CN10-40 CN10-24		DO-1	○	○	○	○
Alarm code 3	ACD3	CN10-41 CN10-25		DO-1	○	○	○	○
Variable gain selection	CDPS		Same as the one of when used with only a servo amplifier. Refer to section 2.3 (1) (b).	DO-1	△	△	△	△
Absolute position undetermined	ABSV			DO-1	△	△	△	△
During tough drive	MTTR			DO-1	△	△	△	△
During fully closed loop control	CLDS			DO-1	△	△	△	
Under cam control	CAMS		It turns on when the control switches to the cam control. It turns off when the control switches to the normal positioning control.	DO-1	△	△	△	
Cam position compensation execution completed	CPCC		It turns on when the cam compensation execution is enabled. It turns on when the position compensation is not being executed during the cam control.	DO-1	△	△	△	
Clutch on/off status	CLTS		It turns on with clutch-on. It is always off when [Cam control data No. 36 - Main shaft clutch control setting] is set to "_ _ _ 0".	DO-1	△	△	△	
Clutch smoothing status	CLTSM		It outputs clutch smoothing status. The output depends on the setting in [Cam control data No. 42 - Main shaft clutch smoothing system] as follows: 0: Direct Always off 1: Time constant method (index) Always on in clutch-on status It turns off when the clutch is off and the smoothing is complete.	DO-1	△	△	△	

11. MR-D01 EXTENSION I/O UNIT

(2) Input signal

Device	Symbol	Connector pin No.	Function and application	I/O division	Control mode			
					$\frac{P}{C}$	BCD	$\frac{J}{L}$	$\frac{S}{R}$
Analog torque limit	OTLA	CN20-12	To use this signal, set [Pr. Po11] to "_1_". When OTLA is enabled, torque is limited in the full servo motor output torque range. Apply 0 V to +10 V DC between OTLA and LG. Connect + of the power supply to OTLA. The maximum torque is generated at +10 V. Resolution: 12 bits	Analog input	Δ	Δ	Δ	Δ
Analog override	OVC	CN20-2	To use this signal, set [Pr. Po11] to "__1_". The signal controls the servo motor setting speed by applying -10 V to +10V DC to between VC and LG. The percentage will be 0% with -10 V, 100% with 0 V, and 200% with +10 V to the servo motor setting speed. Resolution: 12 bits	Analog input	Δ	Δ	Δ	

(3) Output signal

Device	Symbol	Connector pin No.	Function and application	I/O division	Control mode			
					$\frac{P}{C}$	BCD	$\frac{J}{L}$	$\frac{S}{R}$
Analog monitor 1	OMO1	CN20-4	This signal outputs the data set in [Pr. Po13] to between OMO1 and LG in terms of voltage. Resolution: 12 bits or equivalent	Analog output	\circ	\circ	\circ	\circ
Analog monitor 2	OMO2	CN20-14	This signal outputs the data set in [Pr. Po14] to between OMO2 and LG in terms of voltage. Resolution: 12 bits or equivalent	Analog output	\circ	\circ	\circ	\circ

(4) Power supply

Device	Symbol	Connector pin No.	Function and application	I/O division	Control mode			
					$\frac{P}{C}$	BCD	$\frac{J}{L}$	$\frac{S}{R}$
MR-D01 digital I/F power supply input	DICOMD	CN10-13 CN10-14	Input 24 V DC (24 V DC \pm 10% 800 mA) for I/O interface. The power supply capacity changes depending on the number of I/O interface points to be used. For sink interface, connect + of 24 V DC external power supply. For source interface, connect - of 24 V DC external power supply.		\circ	\circ	\circ	\circ
MR-D01 digital I/F common	DOCOMD	CN10-37	Common terminal of input signals such as SON, RES, and others of the servo amplifier. This is separated from LG. For sink interface, connect - of 24 V DC external power supply. For source interface, connect + of 24 V DC external power supply.		\circ	\circ	\circ	\circ
15 V DC power supply	P15R	CN20-13	This outputs 15 V DC to between P15R and LG. This is available as the power for OTLA and OVC. Permissible current: 30 mA		\circ	\circ	\circ	\circ
-12 V DC power supply	N12R	CN20-15	This outputs -12 V DC to between N12R and LG. This is available as the power for VC. However, the voltage varies within the range of -12 V to -15 V. Permissible current: 30 mA		\circ	\circ	\circ	\circ
Control common	LG	CN20-1 CN20-9 CN20-11	This is a common terminal for OTLA, OVC, OMO1, OMO2, and P15R. Pins are connected internally.		\circ	\circ	\circ	\circ
Shield	SD	CN10-50 plate	Connect the external conductor of the shielded wire.		\circ	\circ	\circ	\circ

11. MR-D01 EXTENSION I/O UNIT

(5) Analog override

POINT
<ul style="list-style-type: none"> ● To use OVC (analog override), set [Pr. Po11] to " __ 1 _". ● The override function has two types. One is analog override by using analog voltage input and another is digital override by using parameter settings. <ul style="list-style-type: none"> ▪ Analog override target method: Point table method/program method ▪ Digital override target method: Indexer method ● OVR (Analog override selection) is for the analog override. The digital override does not depend on OVR (Analog override selection). ● Refer to [Pr. PT38], [Pr. PT42], and [Pr. PT43] for the digital override. ● When using the analog override in the point table method or program method, enable OVR (Analog override selection). ● The following shows usable functions and non-usable functions. <ul style="list-style-type: none"> (1) Analog override usable <ul style="list-style-type: none"> ▪ Automatic operation mode (point table method/program method) ▪ JOG operation in the manual operation mode ▪ Automatic positioning to home position function in the point table method (2) Analog override unusable <ul style="list-style-type: none"> ▪ Manual pulse generator operation in the manual operation mode ▪ Home position return mode ▪ Test operation mode using MR Configurator2 (positioning operation/JOG operation)

You can change the servo motor speed by using OVC (Analog override). The following table shows signals and parameters related to the analog override.

Item	Name	Remark
Analog input signal	OVC (Analog override)	To use OVC (analog override), set [Pr. Po11] to " __ 1 _".
Contact input signal	OVR (Analog override selection)	Turning on OVR enables the OVC (Analog override) setting value.
Parameter	[Pr. Po21 D01 override offset]	-9999 to 9999 [mV]

(a) OVC (Analog override)

You can continuously set changed values from outside by applying voltage (-10 to +10 V) to OVC (Analog override). The following shows percentage of the actual speed to input voltage and set speed.

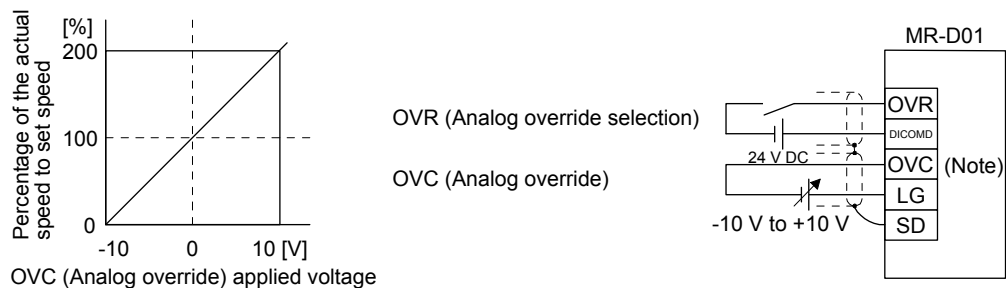

Note. This diagram shows sink input interface.

11. MR-D01 EXTENSION I/O UNIT

- (b) OVR (Analog override selection)
 Enable or disable OVC (Analog override).

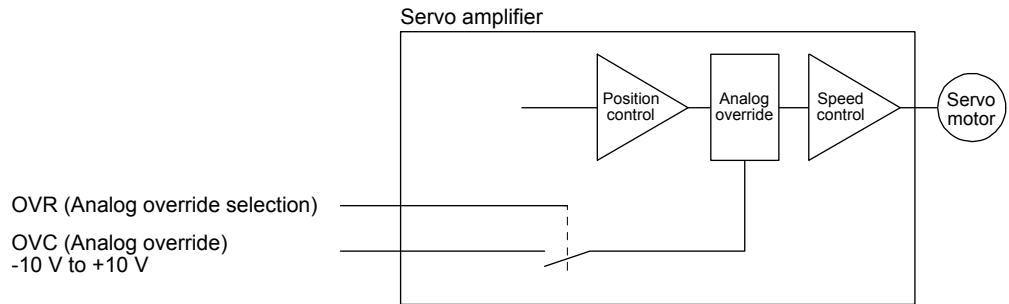

Select a changed value by using OVR (Analog override selection).

(Note) External input signal	Speed change value
0	No change
1	Setting of OVC (Analog override) is enabled.

Note. 0: Off
 1: On

- (c) Analog override offset ([Pr. Po21])
 You can set an offset voltage to the input voltage of OVC (Analog override) with [Pr. Po21]. The setting value ranges from -9999 to +9999 [mV].

11. MR-D01 EXTENSION I/O UNIT

(6) Torque limit

CAUTION

- If the torque limit is canceled during servo-lock, the servo motor may suddenly rotate according to position deviation in respect to the command position.
- When using the torque limit, check that [Pr. PB06 Load to motor inertia ratio/load to motor mass ratio] is set properly. Improper settings may cause an unexpected operation such as an overshoot.

POINT

- To use OTLA (Analog torque limit), set [Pr. Po11] to "_ 1 _ _".

(a) Torque limit and torque

By setting [Pr. PA11 Forward rotation torque limit] or [Pr. PA12 Reverse rotation torque limit], torque is always limited to the maximum value during operation. A relation between the limit value and servo motor torque is as follows.

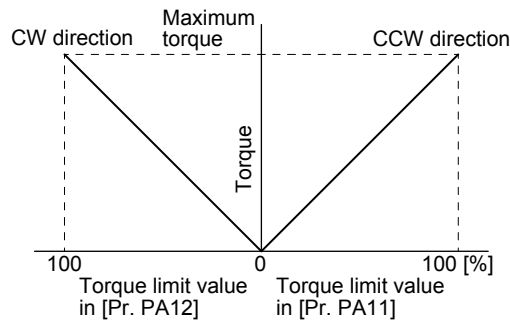

A relation between the applied voltage of OTLA (Analog torque limit) and the torque limit value of the servo motor is as follows. Torque limit values will vary about 5% relative to the voltage depending on products. At the voltage of less than 0.05 V, torque may vary as it may not be limited sufficiently. Therefore, use this function at the voltage of 0.05 V or more.

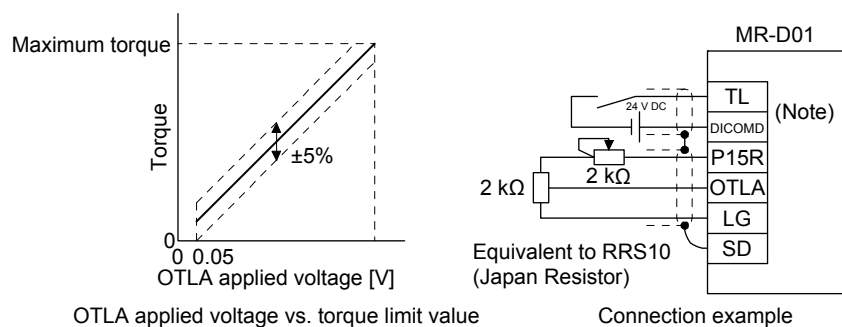

Note. This diagram shows sink I/O interface. For source I/O interface, refer to section 11.5.5 (5).

(b) Torque limit value selection

The following shows how to select a torque limit using TL (External torque limit selection) from [Pr. PA11 Forward torque limit] or [Pr. PA12 Reverse torque limit] and OTLA (Analog torque limit). When TL1 (Internal torque limit selection) is enabled with [Pr. Po02] to [Pr. Po07], [Pr. Po27], and [Pr. Po28], you can select [Pr. PC35 internal torque limit 2/Internal thrust limit 2]. However, if [Pr. PA11] and [Pr. PA12] value is less than the limit value selected by TL/TL1, [Pr. PA11] and [Pr. PA12] value will be enabled.

11. MR-D01 EXTENSION I/O UNIT

(Note) Input device		Limit value status	Enabled torque limit value	
TL1	TL		CCW power running/ CW regeneration	CW power running/ CCW regeneration
0	0		Pr. PA11	Pr. PA12
0	1	OTLA > Pr. PA11 Pr. PA12	Pr. PA11	Pr. PA12
		OTLA < Pr. PA11 Pr. PA12	OTLA	OTLA
1	0	Pr. PC35 > Pr. PA11 Pr. PA12	Pr. PA11	Pr. PA12
		Pr. PC35 < Pr. PA11 Pr. PA12	Pr. PC35	Pr. PC35
1	1	OTLA > Pr. PC35	Pr. PC35	Pr. PC35
		OTLA < Pr. PC35	OTLA	OTLA

Note. 0: Off
1: On

(c) TLC (Limiting torque)

TLC turns on when the servo motor torque reaches the torque limited using the forward rotation torque limit, reverse rotation torque limit or analog torque limit.

11. MR-D01 EXTENSION I/O UNIT

11.5.4 Interfaces

(1) Internal connection diagram

The following shows an example of internal connection diagram of the point table method in a BCD input positioning operation. For the internal connection diagram of the servo amplifier, refer to section 2.5.1.

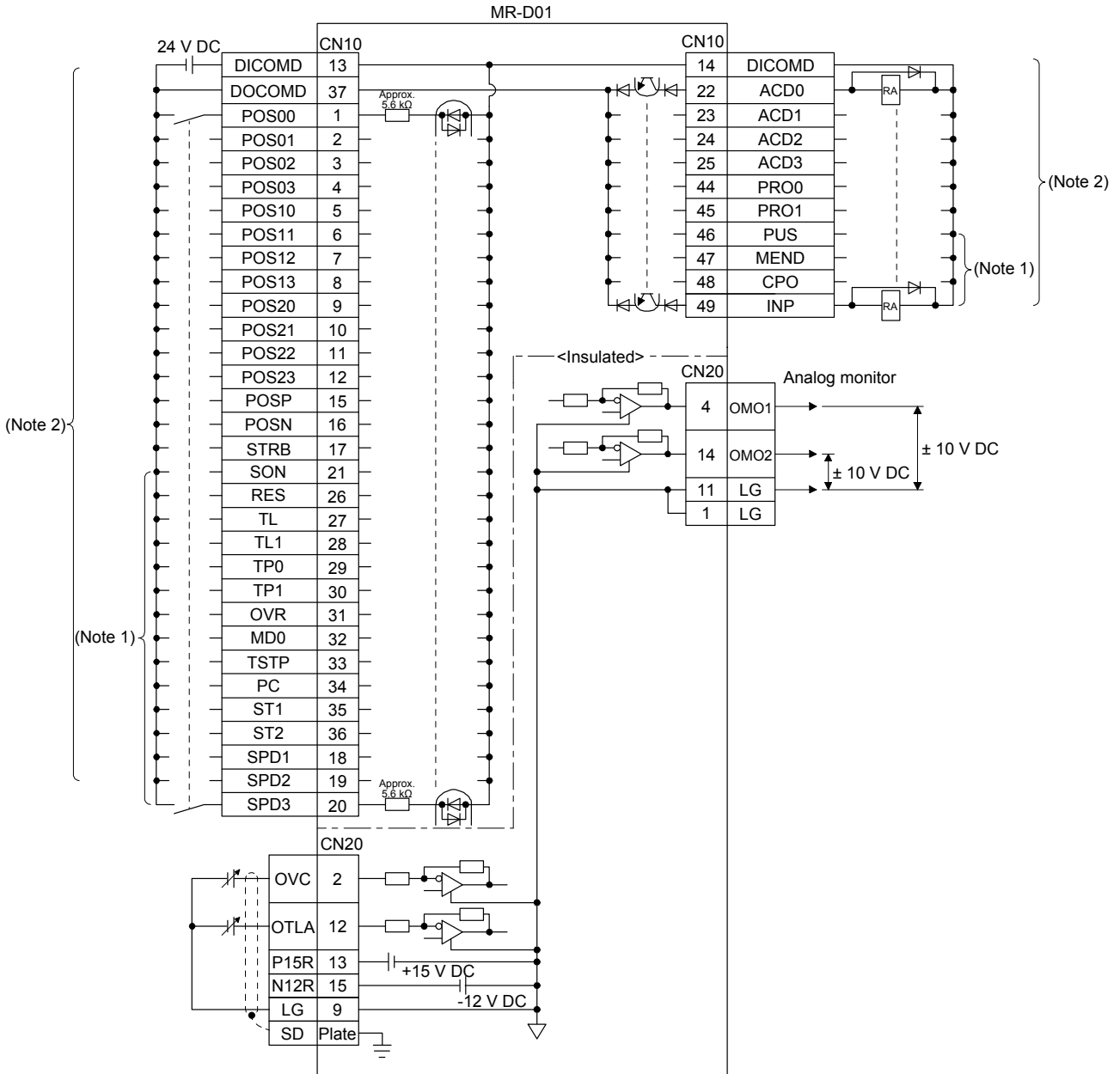

Note 1. The devices can be changed by [Pr. Po02] to [Pr. Po07], [Pr. Po27], and [Pr. PD28].

Note 2. This diagram shows sink I/O interface. For source I/O interface, refer to section 2.5.3.

11. MR-D01 EXTENSION I/O UNIT

(2) Detailed explanation of interfaces

This section provides the details of the I/O signal interfaces (refer to the I/O division in the table) given in section 11.5.3. Refer to the following and make connection with the external device.

(a) Digital input interface DI-1

This is an input circuit whose photocoupler cathode side is input terminal. Transmit signals from sink (open-collector) type transistor output, relay switch, etc. The following is a connection diagram for sink input.

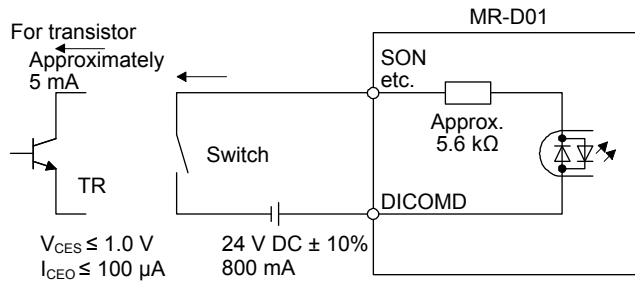

(b) Digital output interface DO-1

This is a circuit in which the collector of the output transistor is the output terminal. When the output transistor is turned on, the current will flow from the collector terminal.

A lamp, relay, or photocoupler can be driven. Install a diode (D) for an inductive load, or install an inrush current suppressing resistor (R) for a lamp load.

(Rated current: 40 mA or less, maximum current: 50 mA or less, inrush current: 100 mA or less) A maximum of 2.6 V voltage drop occurs in the servo amplifier.

The following shows a connection diagram for sink output.

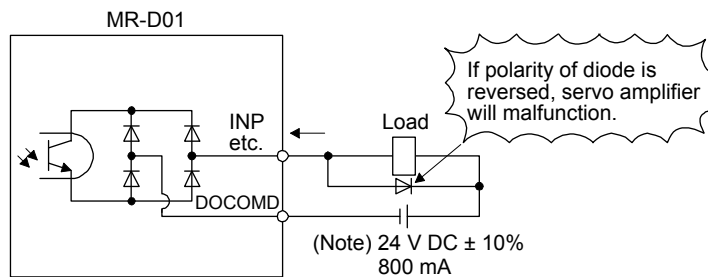

Note. If the voltage drop (maximum of 2.6 V) interferes with the relay operation, apply a high voltage (maximum of 26.4 V) from an external source.

11. MR-D01 EXTENSION I/O UNIT

- (3) Analog input
 Input impedance
 10 kΩ to 12 kΩ

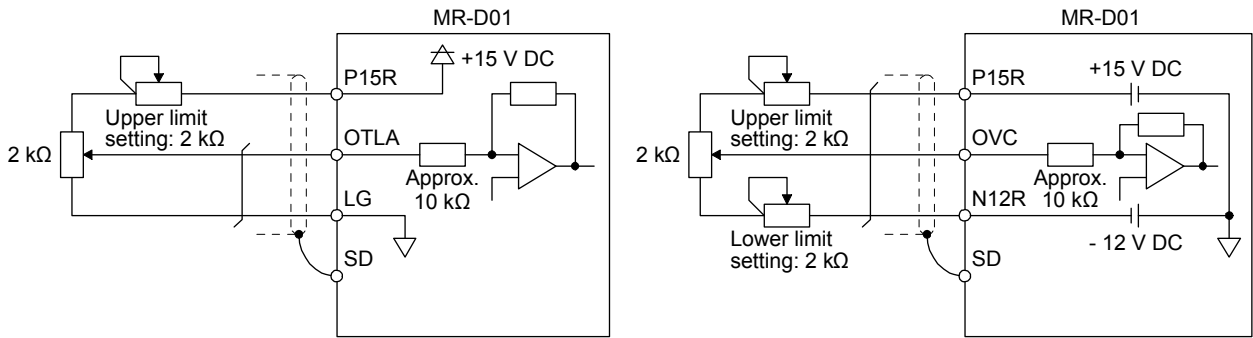

- (4) Analog output

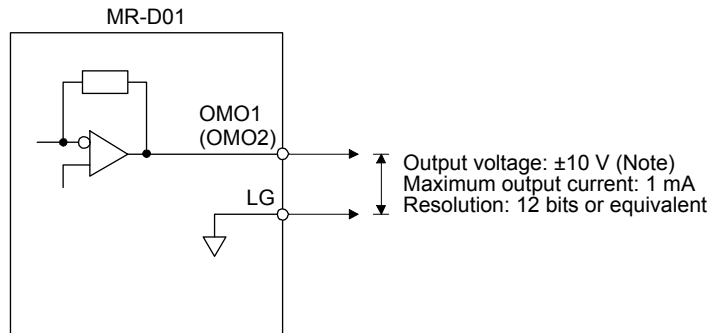

Note. Output voltage range varies depending on the monitored signal. When connecting analog output to an external device, use the withstand voltage of 15 V DC or higher.

11. MR-D01 EXTENSION I/O UNIT

(5) Source I/O interface

In this servo amplifier, source type I/O interfaces can be used.

(a) Digital input interface DI-1

This is an input circuit in which the anode of the photocoupler is the input terminal. Transmit signals from a source (open-collector) type transistor output, relay switch, etc.

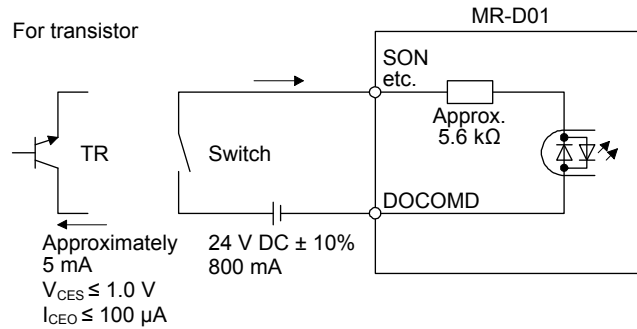

(b) Digital output interface DO-1

This is a circuit in which the emitter of the output transistor is the output terminal. When the output transistor is turned on, the current will flow from the output terminal to a load.

A maximum of 2.6 V voltage drop occurs in the servo amplifier.

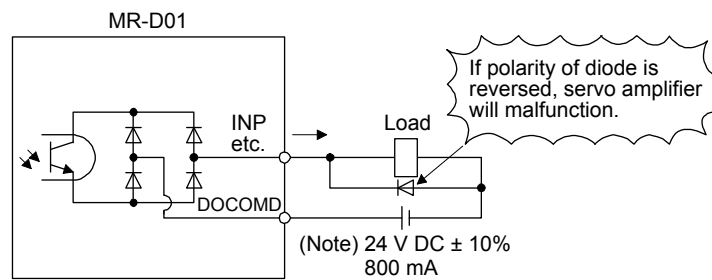

Note. If the voltage drop (maximum of 2.6 V) interferes with the relay operation, apply a high voltage (maximum of 26.4 V) from an external source.

11. MR-D01 EXTENSION I/O UNIT

11.6 Monitor display with MR Configurator2

The following shows how to display the input/output monitor with MR Configurator2 when MR-D01 has been connected.

(1) Initial setting

When MR-D01 has been connected, click "MR-D01" from the "Option unit" menu in the creating new project window of MR Configurator2.

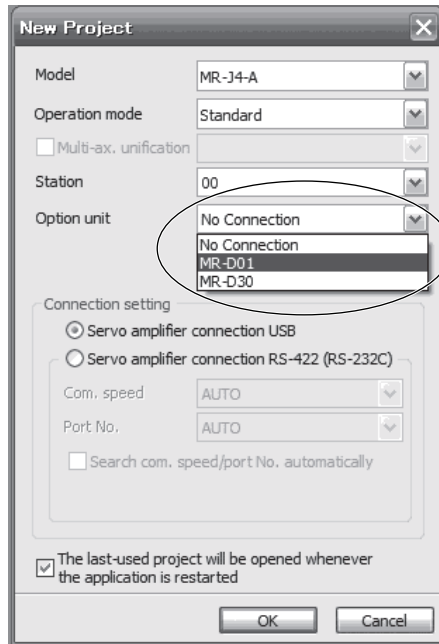

(2) How to open the optional unit monitor window

Click "Monitor" in the menu bar and "I/O Monitor" from the menu.

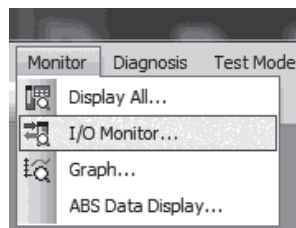

11. MR-D01 EXTENSION I/O UNIT

The following window is displayed. Click "Option unit monitor" in the menu bar.

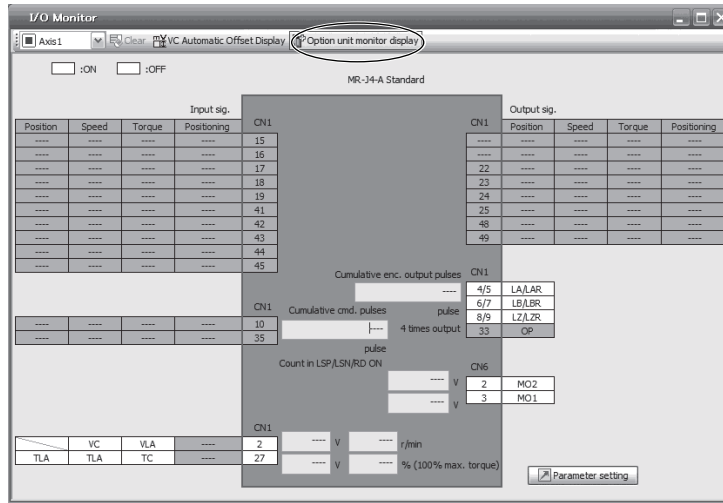

The following window is displayed. The input/output monitor on the MR-D01 side can be checked.

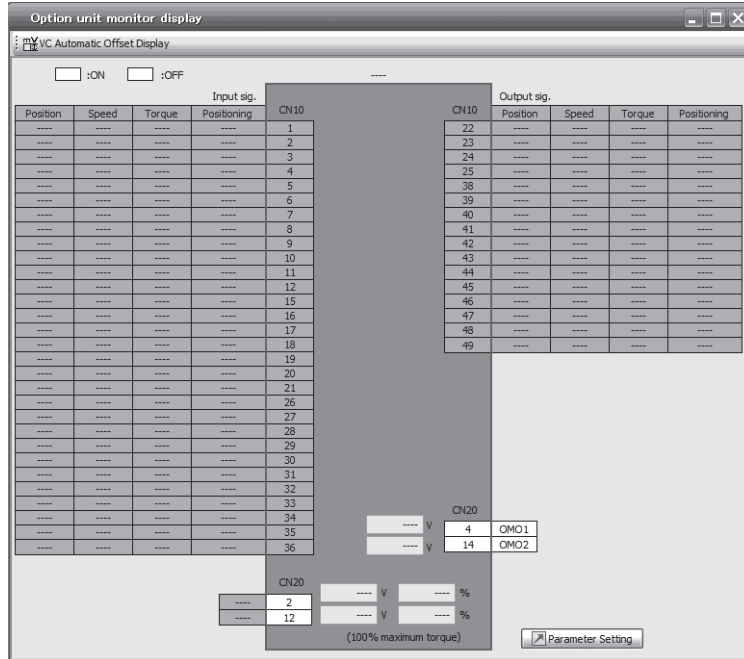

11. MR-D01 EXTENSION I/O UNIT

11.7 Operation

The following items are same as those of MR-J4-_A_-RJ servo amplifiers. For the details of the items, refer to each chapter/section indicated in the detailed explanation field.

Item	Detailed explanation
Startup (except parameter setting)	Section 4.1

11.7.1 Operation mode and selecting method

When MR-D01 is used, the following automatic operation modes in the following table can be selected. Select an operation mode used in the parameter and input device.

Operation mode selection item		[Pr. Po10] setting	Input device setting (Note)		Detailed explanation
			MD0	SPD1 to SPD4	
Automatic operation mode	When using a MR-DS60 digital switch for automatic operation with BCD (3 digits × 2) inputs	---2	On	Any	Section 11.7.2
	When using a programmable controller for automatic operation with BCD (3 digits × 2) inputs				Section 11.7.3

Note. MD0: Automatic/manual selection, SPD1 to SPD4: Speed selection 1 to 4

11.7.2 When using MR-DS60 (6-digit digital switch) for automatic operation with BCD (3-digit × 2) inputs

POINT
<ul style="list-style-type: none"> ● The speed change with the analog override function is enabled in both of the automatic operation mode and manual operation mode. However, it is disabled under the following conditions. <ul style="list-style-type: none"> ▪ During home position return ▪ During deceleration or stop with TSTP (Temporary stop/restart)

Based on the position data set with MR-DS60 (6-digit digital switch) and the selected speed command, positioning is executed. For a connection example of MR-DS60 (6-digit digital switch) and servo amplifier, refer to section 11.5.1 (2) (a).

11. MR-D01 EXTENSION I/O UNIT

(1) Parameter setting

Set the parameters to use BCD (3-digit × 2) inputs with [Pr. Po10]. Refer to the following table and set the parameters as necessary.

No.	Name	Setting digit	Setting item	Setting value	Setting
[Pr. Po10]	Function selection O-1	___x	Operation method	___2	Always set this item. Enable the input/output devices required for BCD input. For the devices to be enabled, refer to section 11.5.2.
		x___	Strobe	2___ (initial value)	STRB (Strobe) is not used. Do not change the initial value.
		_x__	Sign of the position data for BCD positioning	_0__ _1__ (initial value)	6-digit position data without signs (+/-) 6-digit position data with signs (+/-)
[Pr. PT01]	Command mode selection	___x	Positioning command method selection	___0 (initial value)	Absolute value command method
				___1	Incremental value command method
[Pr. PT03]	Feeding function selection	___x	Feed length multiplication [STM]		Refer to section 7.2.9.
[Pr. PA14]	Rotation direction selection/ Travel direction selection		Servo motor rotation direction	0 (initial value)	ST1 (Forward rotation start) on: Rotates the servo motor in the CCW direction. ST2 (Reverse rotation start) on: Rotates the servo motor in the CW direction.
				1	ST1 (Forward rotation start) on: Rotates the servo motor in the CW direction. ST2 (Reverse rotation start) on: Rotates the servo motor in the CCW direction.

(2) Operation

Set position data with the MR-DS60 (6-digit digital switch) and turn on ST1 (Forward rotation start) to move the travel distance of the position data in the forward direction with the rotation speed, acceleration time constant, and deceleration time constant set in the point table selected with SPD1 (Speed selection 1) to SPD4 (Speed selection 4). In the incremental value command method, turning on ST2 (Reverse rotation start) moves the travel distance in the reverse direction.

Select point tables as follows with SPD1 (Speed selection 1) to SPD4 (Speed selection 4) and execute the positioning based on the set rotation speed, acceleration time constant, and deceleration time constant.

In this case, the position data set to the point table is not used.

(Note) Device				Selected Point table No.
SPD4	SPD3	SPD2	SPD1	
0	0	0	1	1
0	0	1	0	2
.
.
.
1	1	0	1	13
1	1	1	0	14
1	1	1	1	15

Note. 0: Off
1: On

11. MR-D01 EXTENSION I/O UNIT

(3) Timing chart

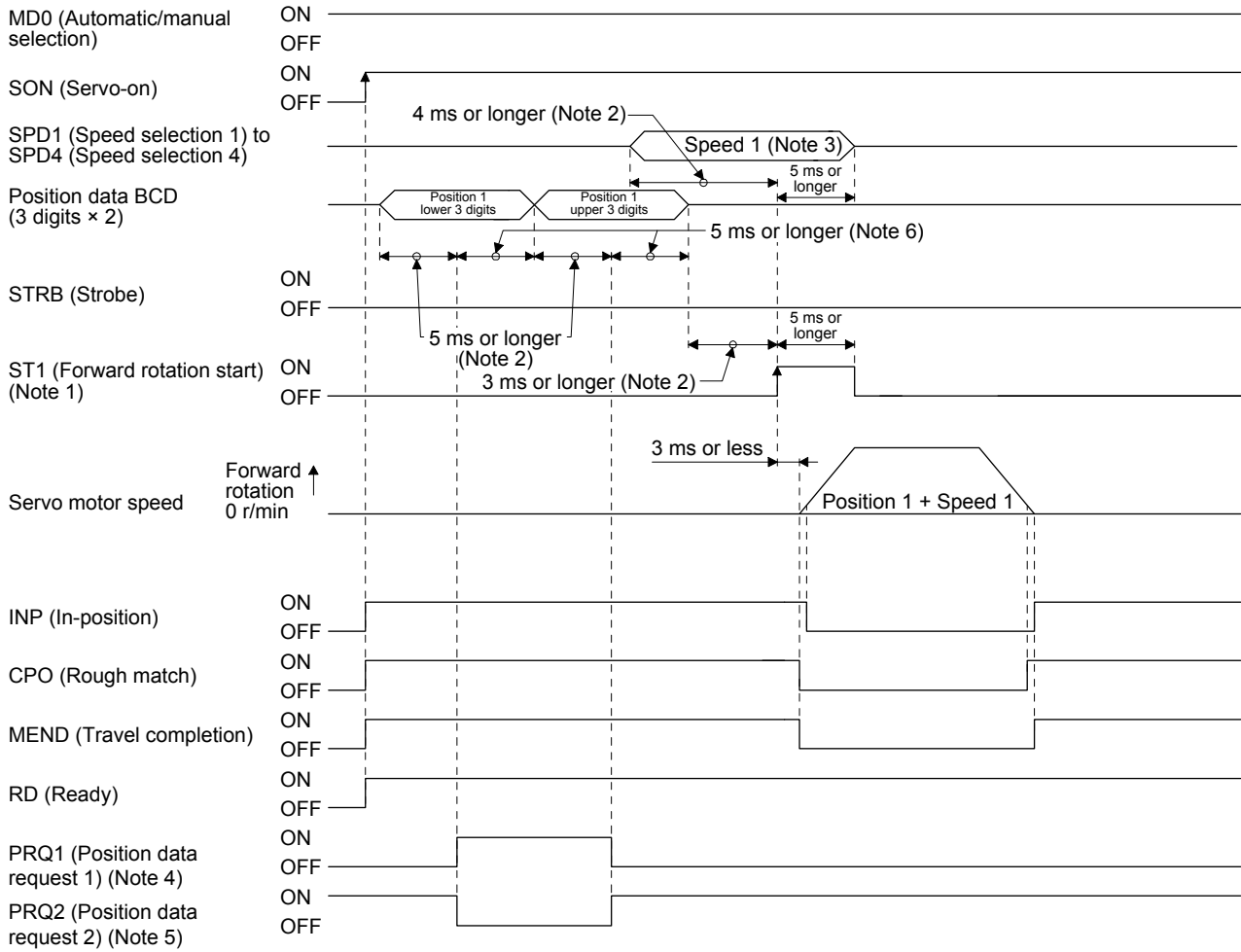

- Note 1. In the incremental value command method, ST2 (Reverse rotation start) can be used. In this case, the timing chart is the same as the one for ST1.
- Note 2. The detection of external input signals is delayed by the time set in the input filter setting of [Pr. PD29]. Considering the output signal sequence from the controller and signal variations due to hardware, configure a sequence that changes the position data earlier.
- Note 3. The speed command selected in Speed selection 1 (SPD1) to 4 (SPD4)
- Note 4. This signal is off when the power is on.
- Note 5. This signal is on when the power is on.
- Note 6. The lower three digits or upper three digits of the position data is changed with "x _ _ _" of [Pr. Po10 MR-D01 data establishment condition].

11. MR-D01 EXTENSION I/O UNIT

(4) Temporary stop/restart during automatic operation

When TSTP (Temporary stop/restart) is switched on during automatic operation, the servo motor decelerates with the deceleration time constant of the point table being executed, and then stops temporarily. Switching on TSTP (Temporary stop/restart) again starts the servo motor rotation for the remaining travel distance.

During a temporary stop, ST1 (Forward rotation start) or ST2 (Reverse rotation start) does not function even if it is switched on.

Changing the automatic mode to manual mode during a temporary stop will erase a travel remaining distance.

The TSTP (Temporary stop/restart) does not function during a home position return or JOG operation.

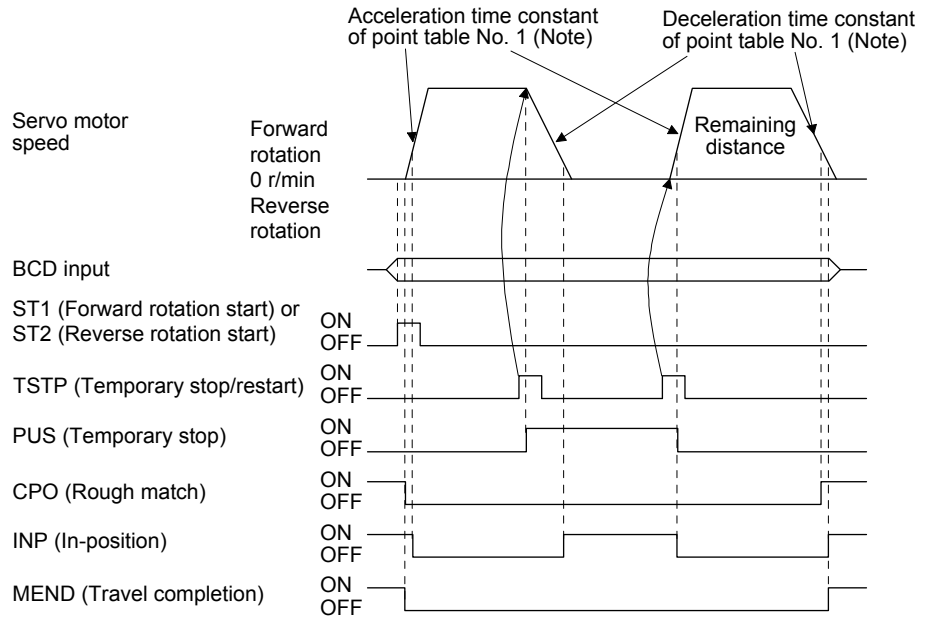

Note. When SPD1 (Speed selection 1) to SPD4 (Speed selection 4) are used, the acceleration/deceleration time constants of the point table selected at the start are used.

11. MR-D01 EXTENSION I/O UNIT

11.7.3 When using a programmable controller for automatic operation with BCD (3 digits × 2) inputs

POINT
<p>● The speed change with the analog override function is enabled in both of the automatic operation mode and manual operation mode. However, it is disabled under the following conditions.</p> <ul style="list-style-type: none"> ▪ During home position return ▪ During deceleration or stop with TSTP (Temporary stop/restart)

Based on the position data set with the programmable controller and the selected speed command, positioning is executed. For a connection example of the programmable controller and servo amplifier, refer to section 11.5.1 (2) (b).

(1) Parameter setting

Set the parameters to use BCD (3 digits × 2) inputs and STRB (Strobe) with [Pr. Po10]. Refer to the following table and set the parameters as necessary.

No.	Name	Setting digit	Setting item	Setting value	Setting
[Pr. Po10]	Function selection O-1	___x	Operation method	___2	Always set this item. Enable the input/output devices required for BCD input. For the devices to be enabled, refer to section 3.4.
		x___	Strobe	0___	Always set this item. When using a programmable controller, STRB (Strobe) is required.
		_x__	Sign of the position data for BCD positioning	_0__ _1__ (initial value)	6-digit position data without signs (+/-) 6-digit position data with signs (+/-)
[Pr. PT01]	Command mode selection	___x	Positioning command method selection	___0 (initial value)	Absolute value command method
				___1	Incremental value command method
[Pr. PT03]	Feeding function selection	___x	Feed length multiplication [STM]	/	Refer to section 7.2.9.
[Pr. PA14]	Rotation direction selection/ Travel direction selection	/	Servo motor rotation direction	0 (initial value)	ST1 (Forward rotation start) on: Rotates the servo motor in the CCW direction. ST2 (Reverse rotation start) on: Rotates the servo motor in the CW direction.
				1	ST1 (Forward rotation start) on: Rotates the servo motor in the CW direction. ST2 (Reverse rotation start) on: Rotates the servo motor in the CCW direction.

11. MR-D01 EXTENSION I/O UNIT

(2) Operation

Set position data with the programmable controller and turn on ST1 (Forward rotation start) to move the travel distance of the position data with the rotation speed, acceleration time constant, and deceleration time constant set in the point table selected with SPD1 (Speed selection 1) to SPD4 (Speed selection 4). In the incremental value command method, turning on ST2 (Reverse rotation start) moves the travel distance in the reverse direction.

Select point tables as follows with SPD1 (Speed selection 1) to SPD4 (Speed selection 4) and execute the positioning based on the set rotation speed, acceleration time constant, and deceleration time constant.

(Note) Device				Selected Point table No.
SPD4	SPD3	SPD2	SPD1	
0	0	0	1	1
0	0	1	0	2
.
.
.
1	1	0	1	13
1	1	1	0	14
1	1	1	1	15

Note. 0: Off

1: On

11. MR-D01 EXTENSION I/O UNIT

(3) Timing chart

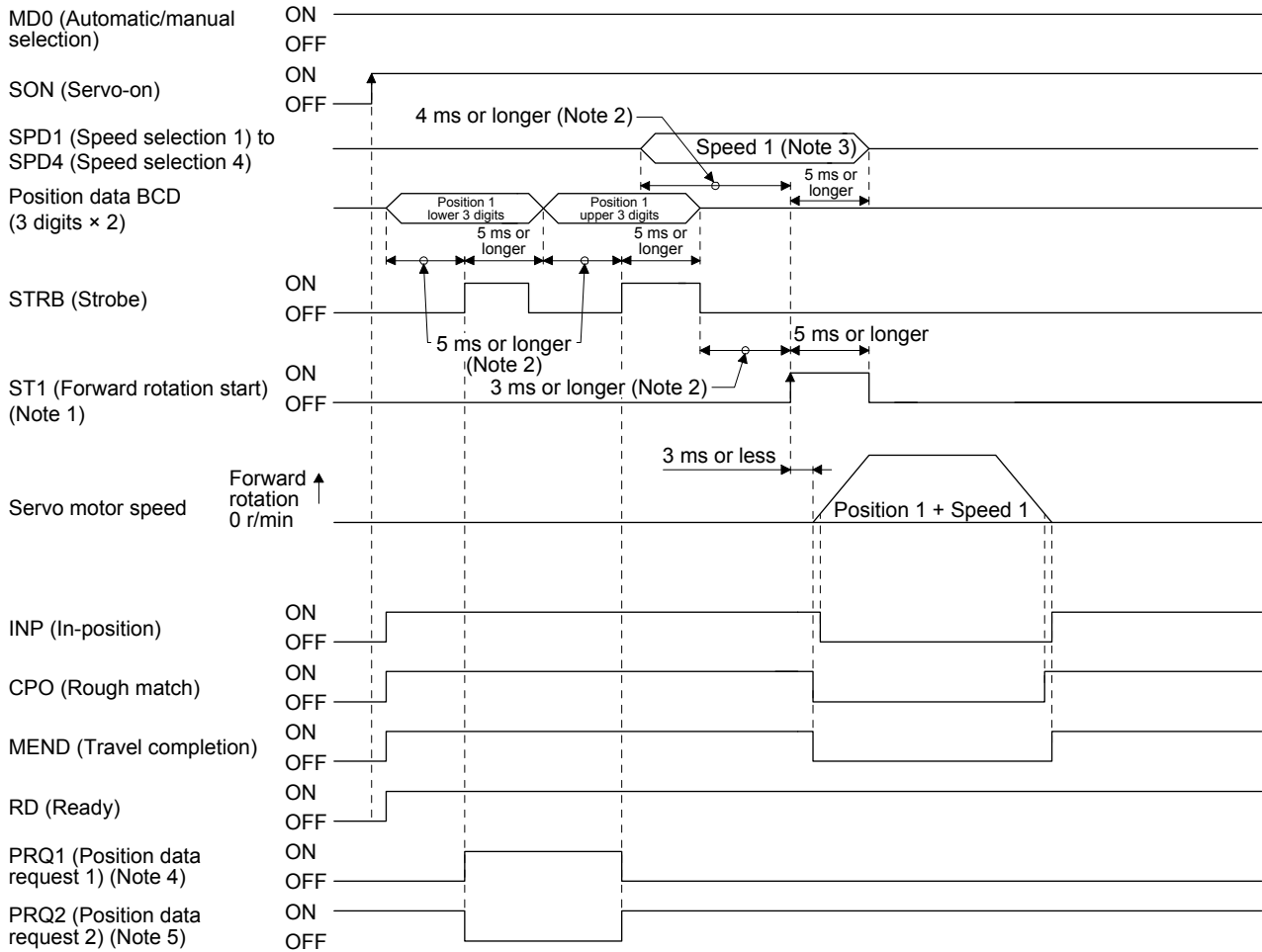

- Note 1. In the incremental value command method, ST2 (Reverse rotation start) can be used. In this case, the timing chart is the same as the one for ST1.
- Note 2. The detection of external input signals is delayed by the time set in the input filter setting of [Pr. PD29]. Considering the output signal sequence from the controller and signal variations due to hardware, configure a sequence that changes the position data earlier.
- Note 3. The speed command selected in Speed selection 1 (SPD1) to 4 (SPD4)
- Note 4. This signal is off when the power is on.
- Note 5. This signal is on when the power is on.

11. MR-D01 EXTENSION I/O UNIT

(4) Temporary stop/restart during automatic operation

When TSTP (Temporary stop/restart) is switched on during automatic operation, the servo motor decelerates with the deceleration time constant of the point table being executed, and then stops temporarily. Switching on TSTP (Temporary stop/restart) again starts the servo motor rotation for the remaining travel distance.

During a temporary stop, ST1 (Forward rotation start) or ST2 (Reverse rotation start) does not function even if it is switched on.

Changing the automatic mode to manual mode during a temporary stop will erase a travel remaining distance.

The TSTP (Temporary stop/restart) does not function during a home position return or JOG operation.

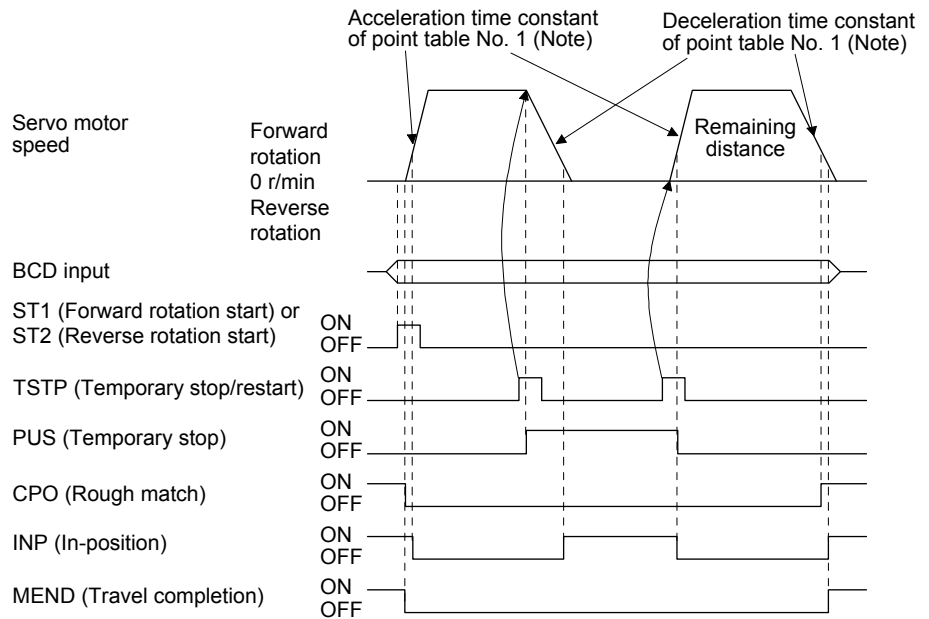

Note. When SPD1 (Speed selection 1) to SPD4 (Speed selection 4) are used, the acceleration/deceleration time constants of the point table selected at the start are used.

11.7.4 Home position return in the BCD (3 digits × 2) input operation

The home position return in the BCD (3 digits × 2) input operation is the same as the one in the point table method. Refer to section 4.4. For the devices, refer to the following table.

Item	Device to be used	Setting
Home position return mode selection	MD0 (Operation mode selection 1)	Switch on MD0.
	SPD1 (Speed selection 1) to SPD4 (Speed selection 4)	Turn off SPD1 to SPD4.
	ST1 (Forward rotation start)	Turn on ST1 for the manual home position return.
	ST2 (Reverse rotation start)	Turn on ST2 for automatic positioning to the home position.

11. MR-D01 EXTENSION I/O UNIT

11.8 Dimensions

11.8.1 MR-D01 extension I/O unit

[Unit: mm]

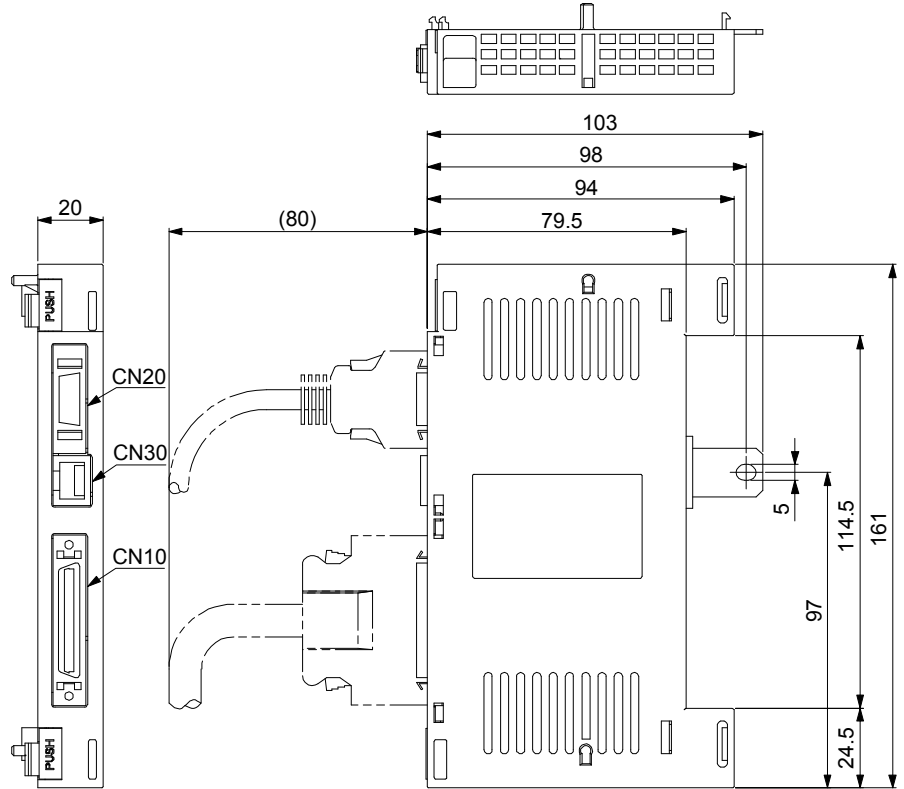

11.8.2 When an MR-D01 extension IO unit is connected to a servo amplifier

100 V/200 V 0.1 kW to 3.5 kW
400 V 0.6 kW to 2 kW
Servo amplifier

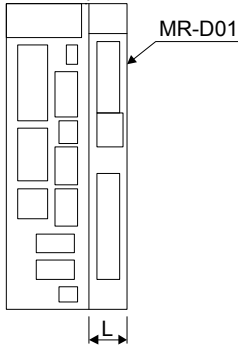

200 V 5 kW/7 kW
400 V 3.5 kW to 7 kW
Servo amplifier

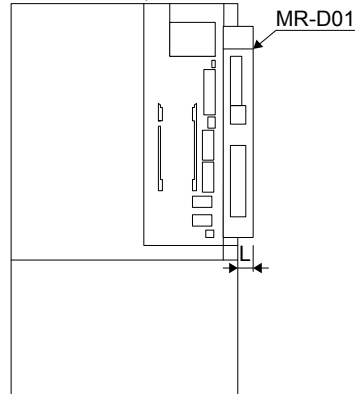





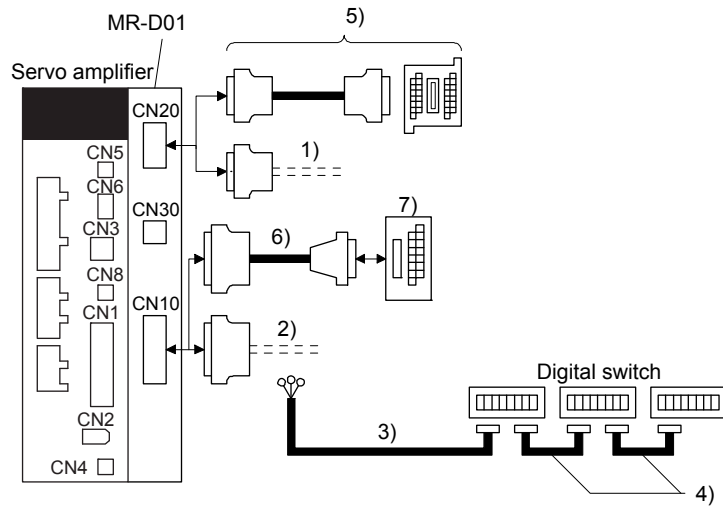

Servo amplifier	L [mm]
MR-J4-10A1-RJ to MR-J4-40A1-RJ MR-J4-10A-RJ to MR-J4-100A-RJ MR-J4-60A4-RJ to MR-J4-100A4-RJ	20
MR-J4-200A-RJ/MR-J4-350A-RJ MR-J4-200A4-RJ	15
MR-J4-500A-RJ/MR-J4-700A-RJ MR-J4-350A4-RJ to MR-J4-700A4-RJ	10
MR-J4-11KA-RJ to MR-J4-22KA-RJ MR-J4-11KA4-RJ to MR-J4-22KA4-RJ	0

11. MR-D01 EXTENSION I/O UNIT

11.9 Options and peripheral equipment

11.9.1 Combinations of cable/connector sets

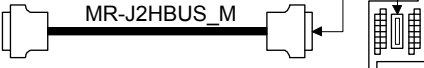

No.	Product name	Model	Description	Application
1)	Connector set	MR-CCN1	 Connector: 10120-3000PE Shell kit: 10320-52F0-008 (3M or equivalent)	
2)	Connector set	MR-J3CN1	 Connector set: 10150-3000PE Shell kit: 10350-52F0-008 (3M or equivalent)	
3)	Digital switch cable	MR-DSCBL_M-G	 Refer to section 11.5.1 (2) (a) and 11.9.2 for details.	For digital switch
4)	Digital switch cable	MR-DSCBL_	 Refer to section 11.5.1 (2) (a) and 11.9.2 for details.	For digital switch junction
5)	Junction terminal block (recommended)		 PS7DW-20V14B-F (Toho Technology Corp.) Junction terminal block PS7DW-20V14B-F is not option. For using the junction terminal block, option MR-J2HBUS_M is necessary. Refer to section 11.9.3 for details.	
6)	Junction terminal block Cable	MR-J2M-CN1TBL_M Cable length: 0.5/1 m (Refer to section 11.9.4.)	Junction terminal block connector Connector: D7950-B500FL (3M)  CN10 connector Connector: 10150-6000EL Shell kit: 10350-3210-000 (3M or equivalent)	For junction terminal block connection
7)	Junction terminal block	MR-TB50	Refer to section 11.9.4.	

11. MR-D01 EXTENSION I/O UNIT

11.9.2 MR-DS60 (6-digit digital switch)

Position data can be provided with BCD signals by using MR-DS60 (6-digit digital switch). For the connection of MR-DS60 and MR-D01, refer to section 11.5.1 (2) (a).

(1) Parameter setting

When using MR-DS60, set [Pr. Po10] to "2 _ 0 2".

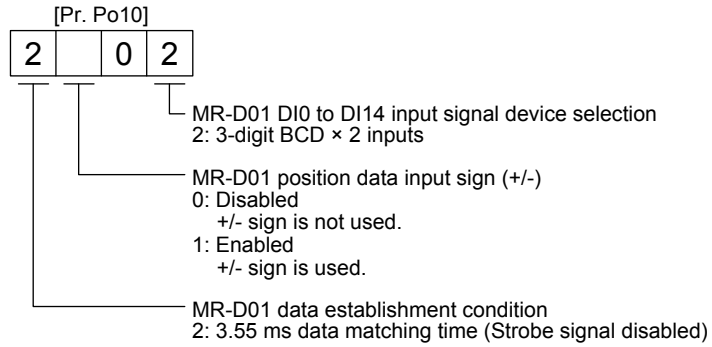

(2) Specifications of MR-DS60

Item	Specifications
Model	MR-DS60
Number of digits	Signed 6-digit BCD
Electrical characteristics	28 V DC (0.5 A)
Withstand voltage	500 Vr.m.s
Contact resistance	100 mΩ or lower
Life	1,000,000 times
Temperature range for operation	0 °C to 60 °C
Storage temperature	-5 °C to 70 °C

(3) Digital switch cable

Use the following digital switch cables and connect them with MR-D01.

Cable model	Cable length					Application
	0.25 m	1 m	3 m	5 m	10 m	
MR-DSCBL_M-G	/	/	3	5	10	Between MR-DS60 and MR-D01
MR-DSCBL_	25	100	/	/	/	Between MR-DS60 and MR-DS60

11. MR-D01 EXTENSION I/O UNIT

(4) Terminal assignment

CON1, CON2		Signal name	Pin No.	Description
10B	10A	DO04	9A	Common output 1 sign, ×1000, ×10000, Common output on ×100000 side
		DO05	9B	Common output 2 signs, ×1, ×10, ×100 side Common output
10B	10A	DI03	6A	×1, ×1000 bit 0
		DI01	6B	×1, ×1000 bit 1
		DI07	7A	×1, ×1000 bit 2
		DI05	7B	×1, ×1000 bit 3
		DI11	4A	×10, ×10000 bit 0
		DI09	4B	×10, ×10000 bit 1
		DI13	5A	×10, ×10000 bit 2
		DI07	5B	×10, ×10000 bit 3
		DI08	2A	×100, ×100000 bit 0
		DI09	2B	×100, ×100000 bit 1
		DI10	3A	×100, ×100000 bit 2
		DI11	3B	×100, ×100000 bit 3
1B	1A	DI12	1A	Sign bit 0+
		DI13	1B	Sign bit 1-

Signal name	Description
DCM2	Common input 2 Connect this signal with COM2 at block selection.
COM2	Common output 2 Common 2 at switching multi steps
DCM1	Common input 1 Connect this signal with COM1 at block selection.
COM1	Common output 1 Common 1 at switching multi steps

TB	
⊗	DCM2
⊗	COM2
⊗	DCM1
⊗	COM1

(5) Dimensions

[Unit: mm]

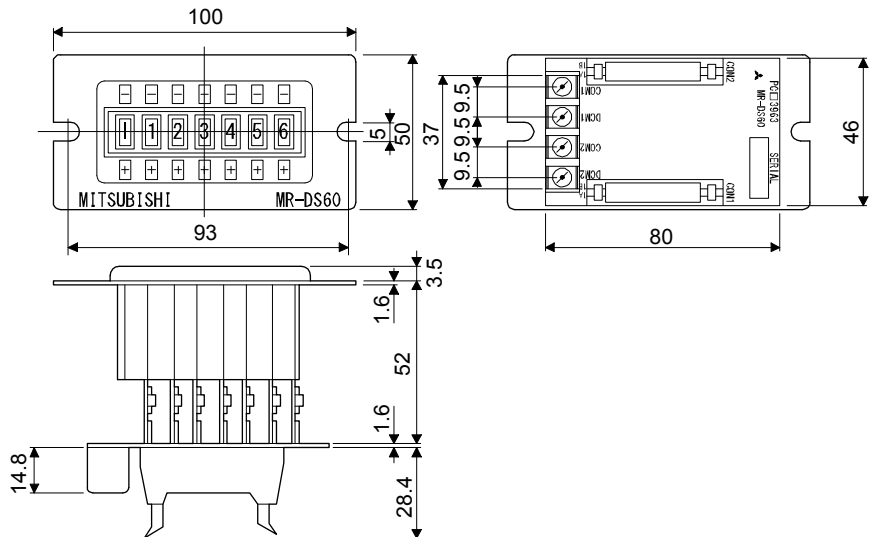

11. MR-D01 EXTENSION I/O UNIT

(6) Mounting

[Unit: mm]

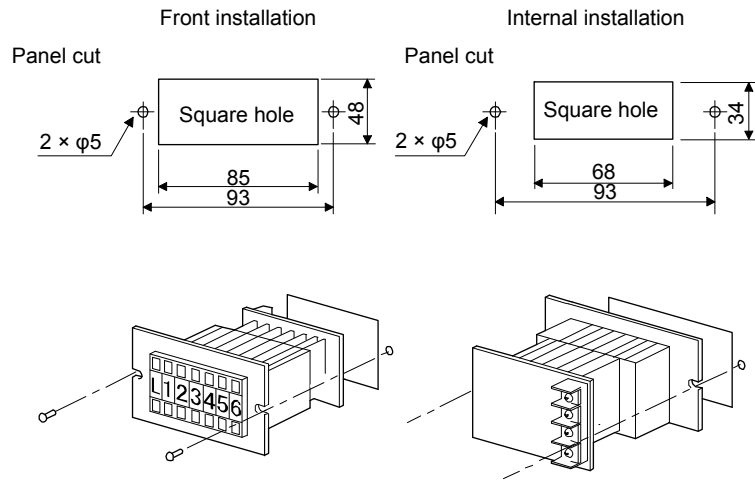

11. MR-D01 EXTENSION I/O UNIT

11.9.3 PS7DW-20V14B-F (Junction terminal block) (recommended)

(1) Usage

Always use the PS7DW-20V14B-F (Junction terminal block) (Toho Technology Corp.) with the option cable (MR-J2HBUS_M) as a set. A connection example is shown below.

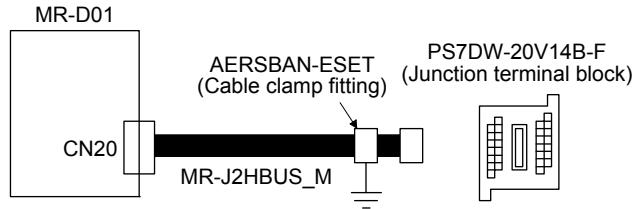

Ground the option cable on the junction terminal block side with AERSBAN-ESET (cable clamp fitting). For how to use the cable clamp fitting, refer to section 11.14 (2) (c) of "MR-J4-_A_(-RJ) Servo Amplifier Instruction Manual".

(2) Connection of MR-J2HBUS_M cable and junction terminal block

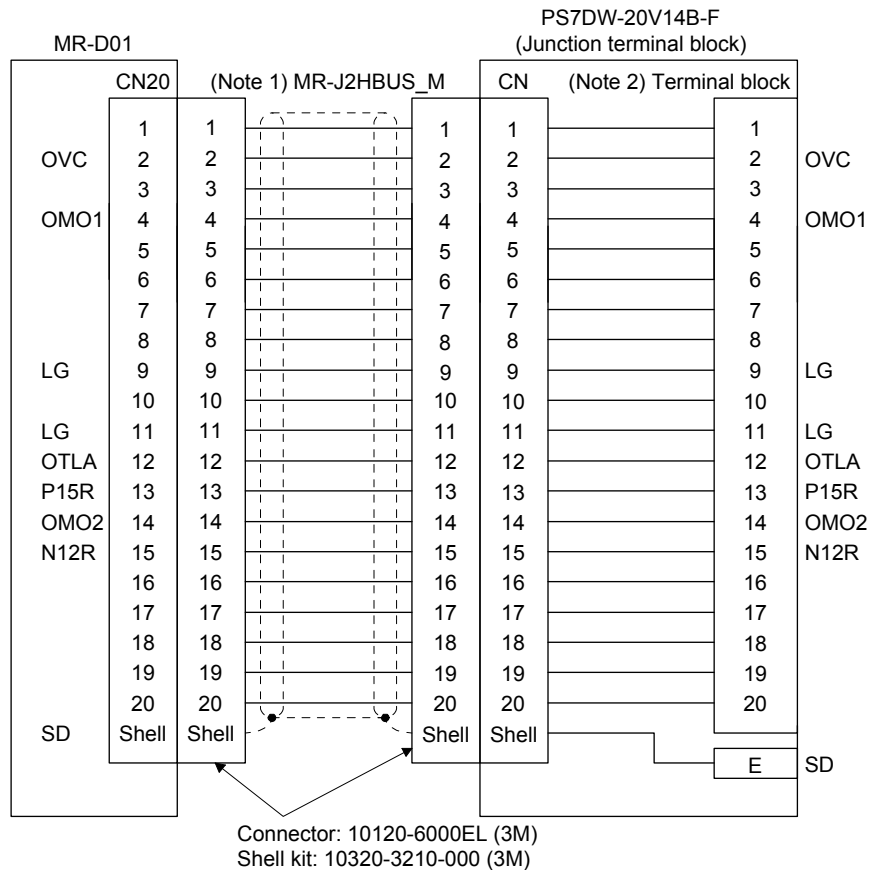

Note 1. Symbol indicating cable length is put in _.

05: 0.5 m

1: 1 m

5: 5 m

2. Do not connect anything to the terminal where no signal has been assigned.

11. MR-D01 EXTENSION I/O UNIT

(3) Dimensions of junction terminal block

[Unit: mm]

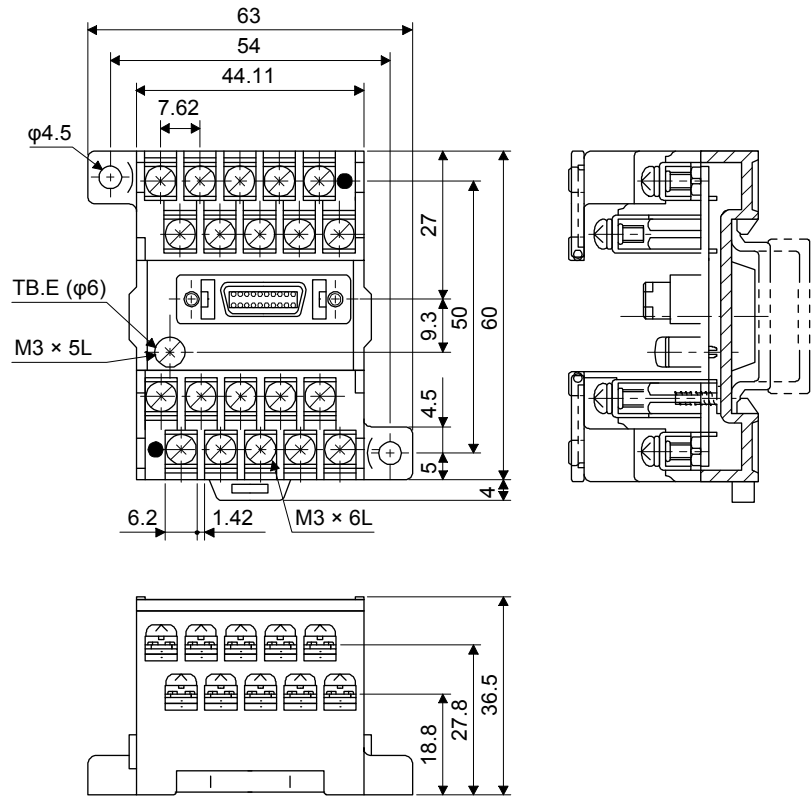

11. MR-D01 EXTENSION I/O UNIT

11.9.4 MR-TB50 (Junction terminal block)

(1) Usage

Always use MR-TB50 (Junction terminal block) with MR-J2M-CN1TBL_M (Junction terminal block cable) as a set.

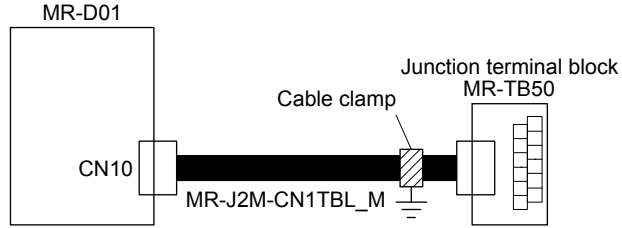

Ground the junction terminal block cable on the junction terminal block side with the supplied AERSBAN-ESET (cable clamp fitting). For how to use the cable clamp fitting, refer to section 11.14 (2) (c) of "MR-J4-_A_(-RJ) Servo Amplifier Instruction Manual".

(2) Dimensions of MR-TB50

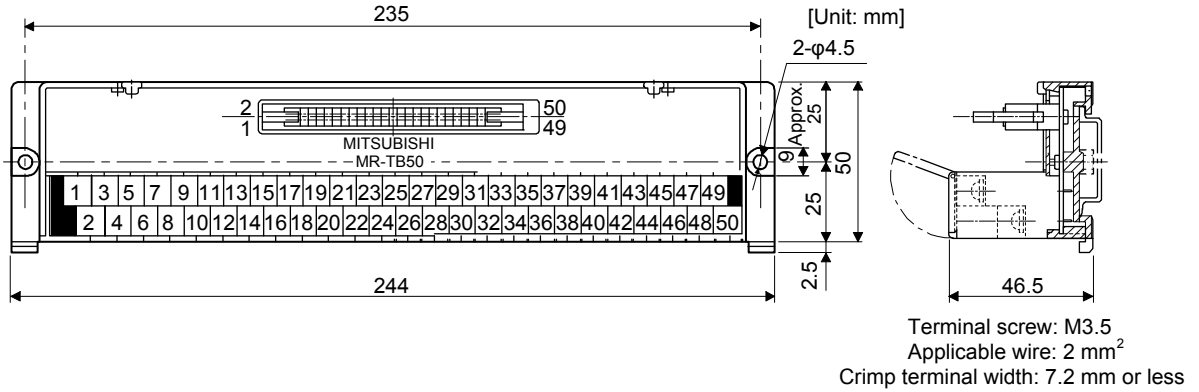

11. MR-D01 EXTENSION I/O UNIT

- (3) Connection diagram of MR-J2M-CN1TBL_M cable and MR-TB50
 The following connection diagram shows BCD input as an example.

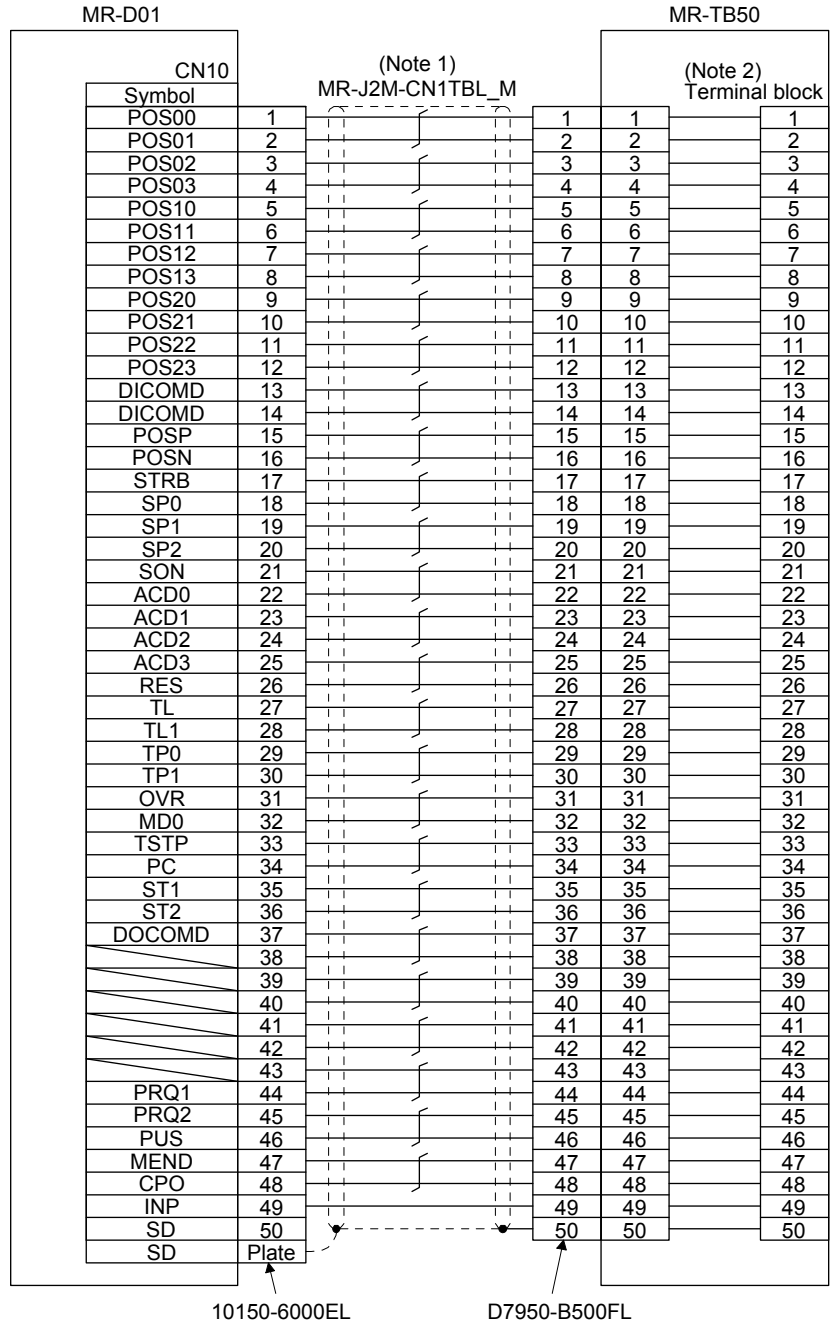

- Note 1. Symbol indicating cable length is put in _.
 05: 0.5 m
 1: 1 m
2. Do not connect anything to the terminal where no signal has been assigned.

12. APPLICATION OF FUNCTIONS

12. APPLICATION OF FUNCTIONS

This chapter explains about application of using positioning function of servo amplifier.



CAUTION

- Note that the number of write times to the Flash-ROM where the cam data is stored is limited to approximately 10000. If the total number of write times exceeds 10000, the servo amplifier may malfunction when the Flash-ROM reaches the end of its useful life.

12.1 Simple cam function

POINT

- The simple cam function is available with servo amplifiers with software version B7 or later.
- The simple cam function can be used with the point table method and the program method.
- This function is not available with the servo amplifier to which the MR-D30 unit has been connected.
- When [AL. F5.2 Cam data miswriting warning] occurs during cam data writing, set [Pr. PT34] to "5010" to initialize the cam data.

12.1.1 Outline of simple cam function

Simple cam function enables synchronous control by using software instead of controlling mechanically with cam.

The following shows a movement trajectory when the cam below is used and the input axis is rotated once.

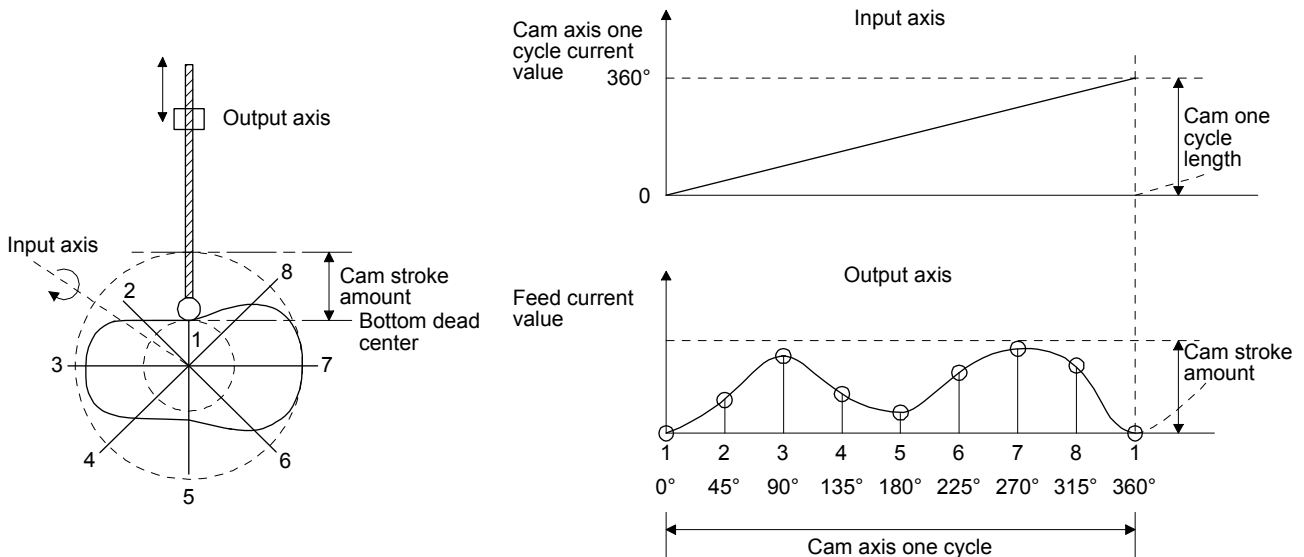

By setting cam data and cam control data, the simple cam function enables synchronous control with an input axis (external pulse command input, point table command, or program positioning command) with a start of positioning.

12. APPLICATION OF FUNCTIONS

12.1.2 Simple cam function block

The function block diagram of the simple cam is shown below. Use MR Configurator2 to set the cam data and the cam control data.

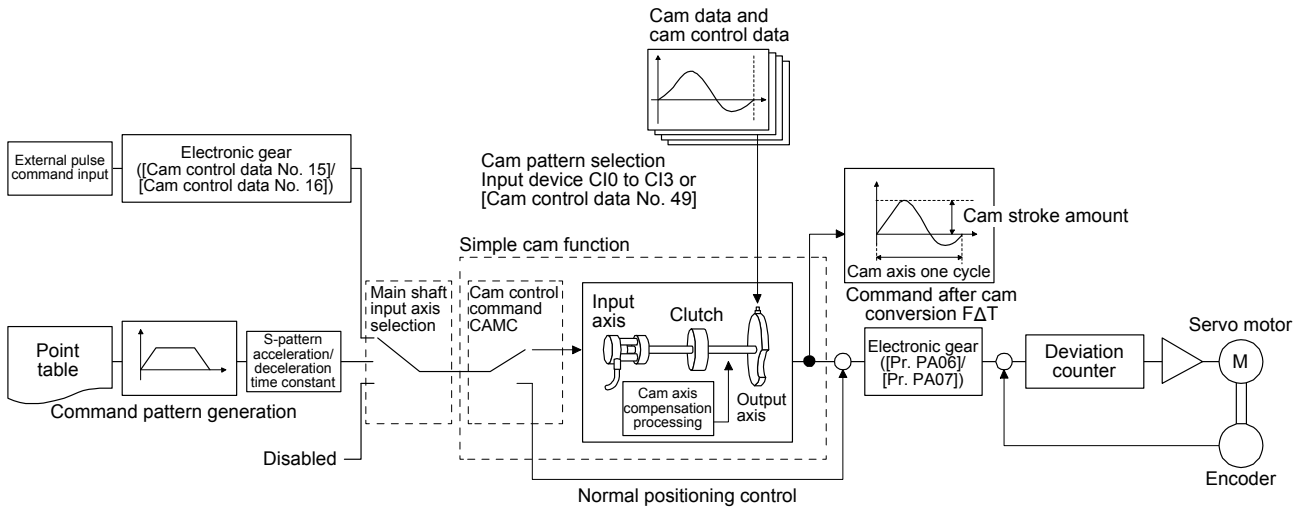

12. APPLICATION OF FUNCTIONS

12.1.3 Simple cam specification list

(1) Specification list

Item		MR-J4-_A	
Memory capacity (Note 1)	Storage area for cam data	8 Kbytes (Flash-ROM)	
	Working area for cam data	8 Kbytes (RAM) (Note 2)	
Number of registration		Max. 8	
Comment		Max. 32 single-byte characters for each cam data	
Cam data and cam control data	Stroke ratio data type	Cam resolution	256/512/1024/2048
		Stroke ratio	-100.000 to 100.000 [%]
	Coordinate data type	Number of coordinate	2 to 1024
		Coordinate data	Input value: 0 to 999999 Output value: -999999 to 999999
Cam curve		12 types (constant speed/constant acceleration/5th curve/single hypotenuse/cycloid/distorted trapezoid/distorted sine/distorted constant speed/trapezoid/reverse trapezoid/double hypotenuse/reverse double hypotenuse)	

- Note
1. The memory capacity includes a use area (storage area for cam data) for storing in the servo amplifier and an actual operation area (working area for cam data).
 2. This can be always changed by using Modbus-RTU communication during servo-off. Refer to section 12.1.7 (5) for the registers used for writing data via Modbus-RTU communication.

(2) Cam resolution

(a) Stroke ratio data type

Cam resolution	Max. number of registration
256	8
512	4
1024	2
2048	1

(b) Coordinate data type

Number of coordinate	Max. number of registration
128	8
256	4
512	2
1024	1

12. APPLICATION OF FUNCTIONS

12.1.4 Control of simple cam function

The following three cam controls are available by setting the cam data and the cam control data with MR Configurator2.

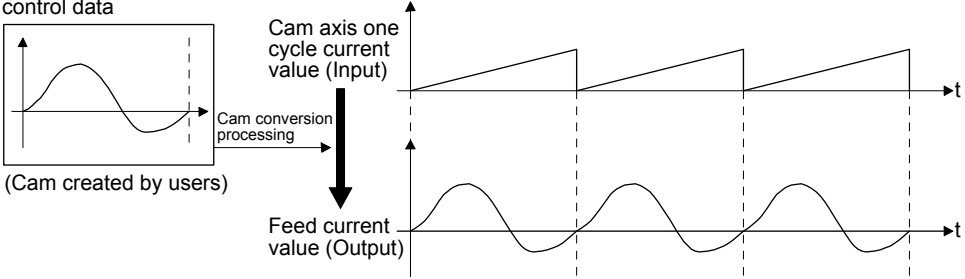
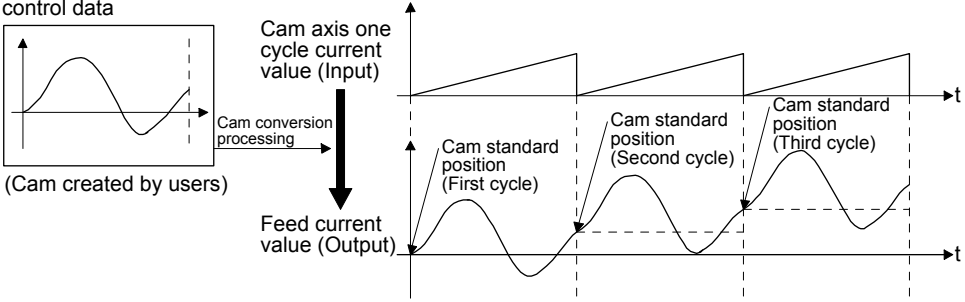
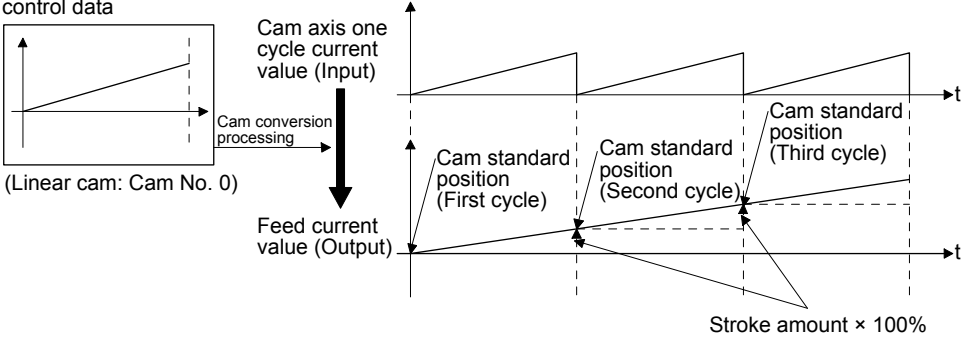
Cam control method	Description	Actual movement
To-and-fro control	Reciprocates within a specified cam stroke.	<p>Cam data and cam control data</p>  <p>The diagram shows a user-created cam curve (sine wave) being converted into a trapezoidal input signal for the cam axis. The resulting output is a reciprocating feed current value that follows the cam curve's profile.</p>
Feed control	Updates a cam standard position per cycle.	<p>Cam data and cam control data</p>  <p>The diagram shows a user-created cam curve being converted into a trapezoidal input signal. The resulting output is a reciprocating feed current value. Vertical dashed lines indicate the 'Cam standard position' at the start of each cycle (First, Second, and Third cycle).</p>
Linear control	Performs linear control to keep the one-cycle stroke ratio as 100%.	<p>Cam data and cam control data</p>  <p>The diagram shows a linear cam data curve being converted into a trapezoidal input signal. The resulting output is a linear feed current value. Vertical dashed lines indicate the 'Cam standard position' at the start of each cycle (First, Second, and Third cycle). A label 'Stroke amount × 100%' is shown at the bottom right.</p>

12. APPLICATION OF FUNCTIONS

12.1.5 Operation in combination with the simple cam

(1) Encoder following function

The servo amplifier receives A/B-phase output signal from a synchronous encoder and starts the servo motor with the signal.

Up to 4 Mpulses/s can be inputted from the synchronous encoder to use with the servo amplifier.

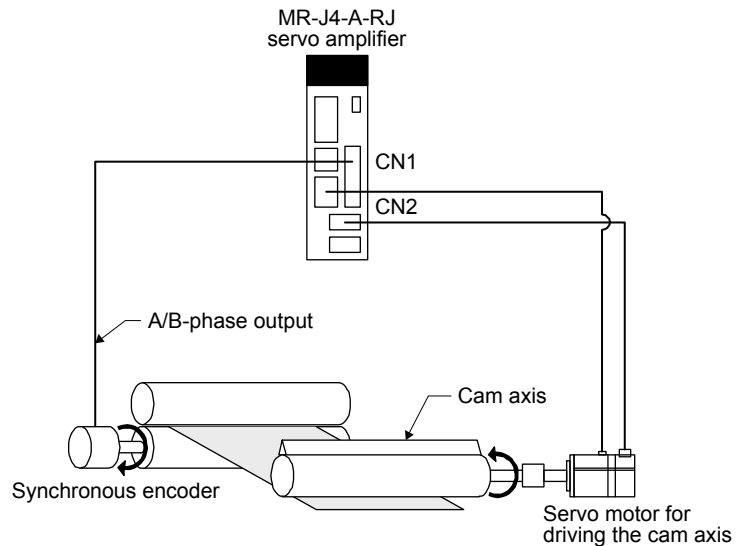

(2) Command pulse input through function

POINT
<ul style="list-style-type: none"> It takes about 150 μs at a maximum per axis to execute the function from inputting to outputting of pulses. <p>Example) When the final axis is n Maximum delay time [μs] = 150 μs \times (n-1)</p>

The command pulse input through function allows the first axis to output A/B-phase pulses received from the synchronous encoder to the next axis, enabling a system in which the second and later axes are synchronized with the conveyor axis.

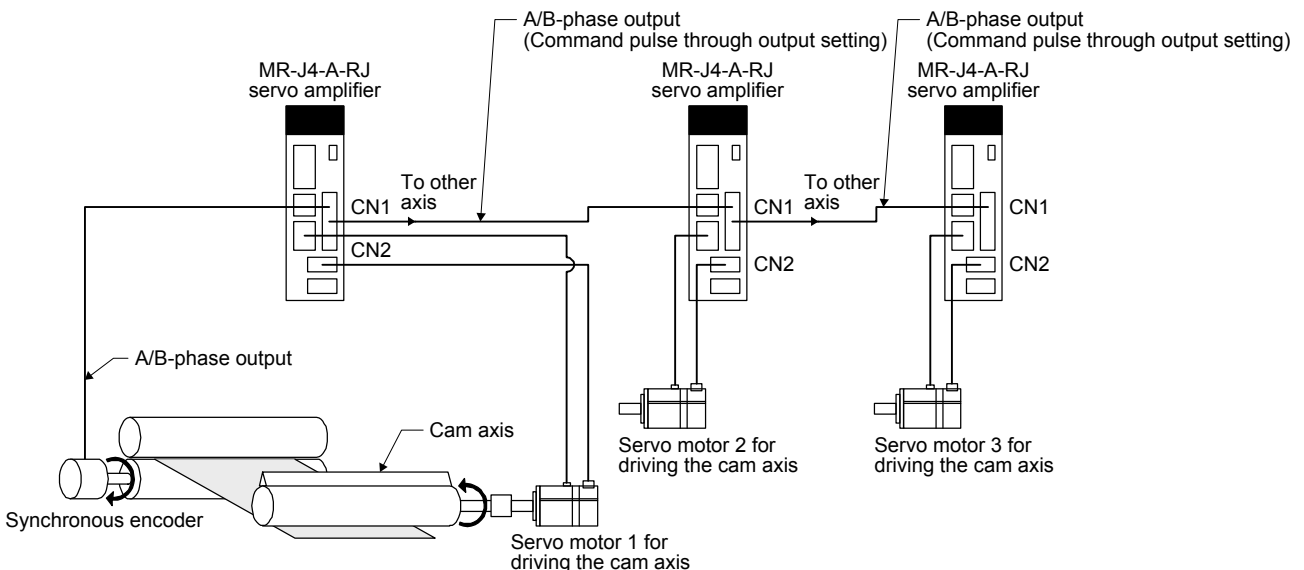

12. APPLICATION OF FUNCTIONS

(3) Mark sensor input compensation function

The servo amplifier receives input signals from a mark sensor, calculates compensation amounts, and corrects position errors of the rotary knife axis.

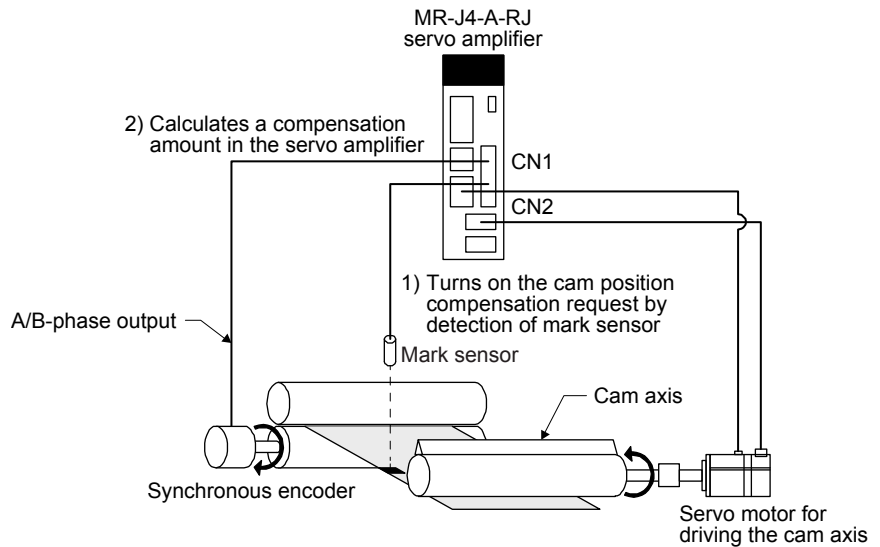

(4) Synchronous operation using positioning data

A synchronous operation is enabled by setting the same positioning data, using a contact input or Modbus-RTU communication, and starting the positioning simultaneously. Refer to section 5.8.4 of "MR-J4-_A_-RJ Servo Amplifier Instruction Manual (Modbus-RTU communication)" for the simultaneous start with Modbus-RTU communication.

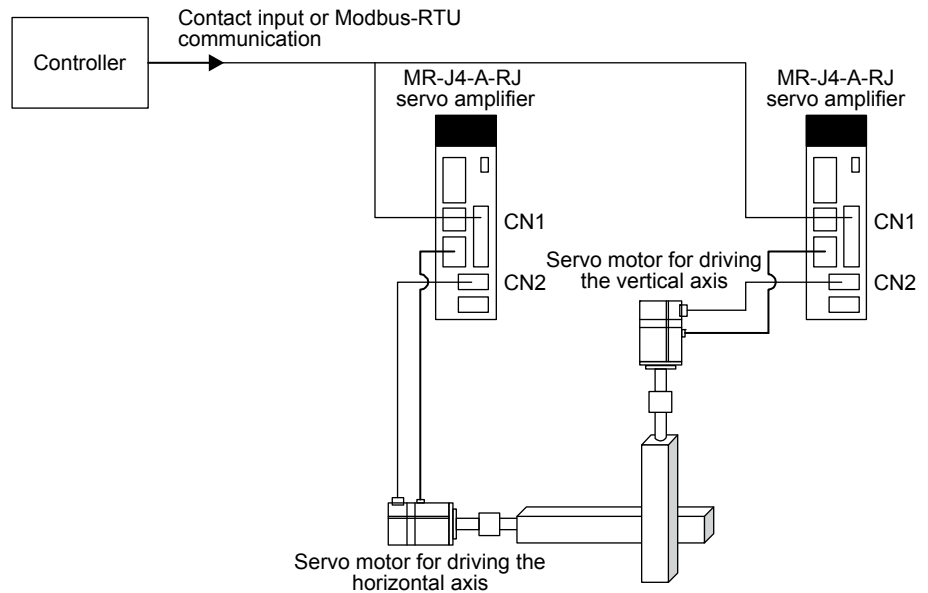

12. APPLICATION OF FUNCTIONS

12.1.6 Setting list

(1) List of items set with MR Configurator2

Set the following on the cam setting window of MR Configurator2.

Setting item		Setting
Cam control data	Main shaft input axis selection	Select a command input method for the cam axis. Select from "encoder following (external pulse input)" and "internal point table".
	Cam No. selection	Select the number to create the cam control data.
	Resolution setting	Set the cam resolution. Select from 256/512/1024/2048.
	Cam axis one cycle length	Set a travel amount of cam one cycle. Command unit is used as an input unit.
	Cam stroke amount	Set a cam stroke amount for the stroke ratio of 100% when using the stroke ratio data type cam control.
Cam data		Create the cam data on the cam creating window of MR Configurator2. After the data is created, write the cam data to the servo amplifier.

(2) List of items set with parameters of the servo amplifier

Set the following with the parameters of the servo amplifier.

Setting item	Setting
Operation mode selection	Select "Positioning mode (point table method or program method)" with [Pr. PA01 Operation mode].
Cam function setting	Enable the cam function with [Pr. PT35 Function selection T-5].
Cam data selection	Select the cam data to be executed with CI0 (Cam No. selection 0) to CI3 (Cam No. selection 3). Selecting the cam data for execution is also possible with [Cam control data No. 49 - Cam No.].
Device setting	Assign CAMC (Cam control command input), CAMS (Output in cam control), and CI0 (Cam No. selection 0) to CI3 (Cam No. selection 3) with I/O setting parameters ([Pr. PD_ _]).

12. APPLICATION OF FUNCTIONS

12.1.7 Data to be used with simple cam function

 CAUTION	<p>● Note that the number of write times to the Flash-ROM where the cam control data and cam data are stored is limited to approximately 10000. If the total number of write times exceeds 10000, the servo amplifier may malfunction when the Flash-ROM reaches the end of its useful life. If data needs to be changed very frequently, use the temporal writing function and write the data to the RAM, not to the Flash-ROM.</p>
--	--

(1) Memory configuration of cam control data and cam data

POINT	<p>● When [AL. F5.2 Cam data miswriting warning] occurs during cam data writing, set [Pr. PT34] to "5010" to initialize the cam data.</p>
--------------	---

The cam control data and the cam data used for the simple cam are stored in Flash-ROM inside the servo amplifier. When the power is turned on, the cam data and the cam control data are copied from the Flash-ROM to the RAM inside the servo amplifier, and then cam control will be executed.

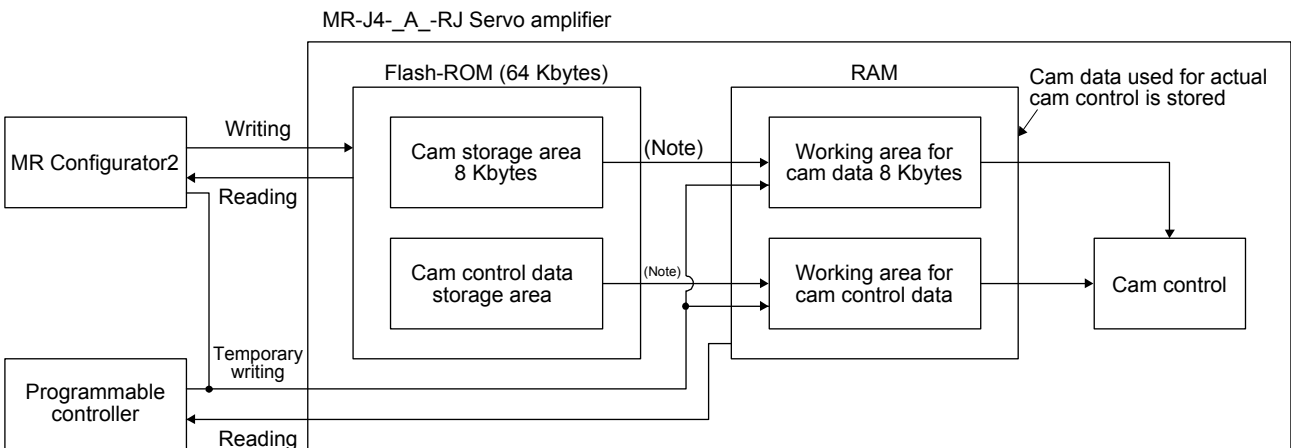

Note. When the power is turned on, the cam data and the cam control data are copied from the Flash-ROM to the RAM.

Use MR Configurator2 or Modbus-RTU communication to write the cam data and the cam control data. Be sure to write the cam data and the cam control data in servo-off state.

When writing the data via Modbus-RTU communication, transfer the cam data created using MR Configurator2.

Modbus-RTU communication uses Request store CAM (2D88h), CAM area (2D89h), and CAM data in CAM area (2D8Bh). Refer to section 12.1.7 (5) for details of each register.

12. APPLICATION OF FUNCTIONS

Two writing methods are available.

Writing method	Description	Data transmission method (Note)	
		MR Configurator2	Modbus-RTU communication
Temporary writing	Write the cam control data and the cam data to the RAM of the servo amplifier. After writing, the cam control data and the cam data will be reflected. The written data will be disabled if the power is turned off. Use this when creating and adjusting the cam control data and the cam data.	○	○
Writing	Write the cam control data and the cam data to the Flash-ROM. The data will be enabled when the power is cycled after writing After cycling the power, control is performed based on the written data. Conduct this after the cam control data and the cam data are finalized.	○	×

Note. ○: Supported, ×: Unsupported

(2) Cam data

POINT
<p>● If the cam data is set incorrectly, the position command and speed command may increase and may cause machine interference or [AL. 31 Overspeed]. When you have created and changed cam data, make sure to perform test operations and make appropriate adjustments.</p>

The following two types are available for the cam data.

Cam data type	Description
Stroke ratio data type	Cam curve of one cycle is divided equally by the number of cam resolution and defined. The cam curve will be created according to the stroke ratio data of the number of cam resolution.
Coordinate data type	Data in which cam curve of one cycle is defined with two or more points. The coordinate data is defined as (input value, output value). The input value will be the cam axis one cycle current value, and the output value will be the stroke value from the cam standard position.

(a) Stroke ratio data type

The following are set in the stroke ratio data type. Set the following items on the cam setting window of MR Configurator2. When "Cam No." is set to "0", straight-line control is performed so that the stroke ratio at the last point of the cam data becomes 100%.

Setting item	Setting	Setting range
Cam No.	Set a Cam No.	0: Linear cam 1 to 8: User-created cam
Setting method	Set "1: Stroke ratio data type".	
Cam resolution	Set the number of divisions for the cam curve of one cycle.	Select from 256/512/1024/2048.
Cam data start position	Set the positions of the cam data and cam control data to the position of when "Cam axis one cycle current value" is "0".	0 to "Cam resolution - 1"
Stroke ratio data	Set the stroke ratio from the first to the last point.	-100.000 to 100.000

12. APPLICATION OF FUNCTIONS

The following is a setting example for "cam resolution = 512" in the stroke ratio data type.

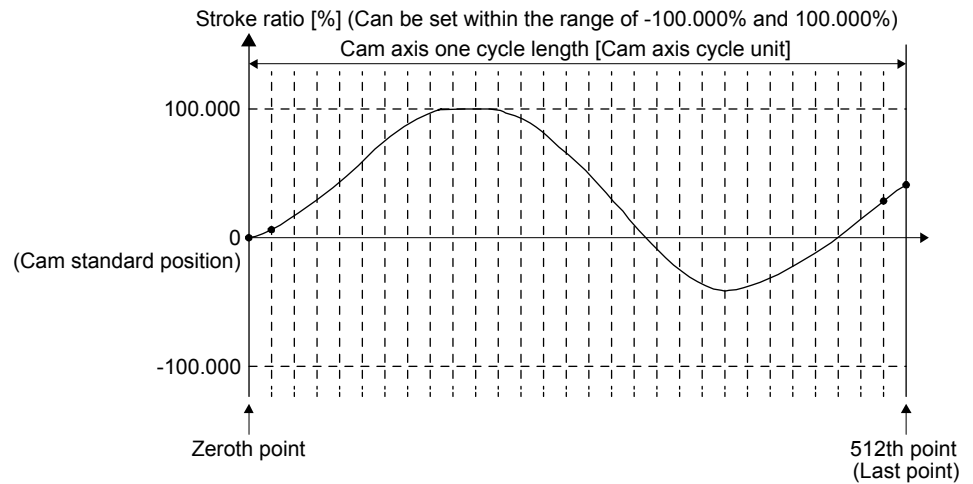

1) Feed current value

The feed current value of the cam axis is calculated as follows:

$$\text{Feed current value} = \text{Cam standard position} + (\text{Cam stroke amount} \times \text{Stroke ratio to cam axis one cycle current value})$$

When the cam axis one cycle current value is in the middle of the specified stroke ratio data, the intermediate value is calculated using the cam data before and after the value.

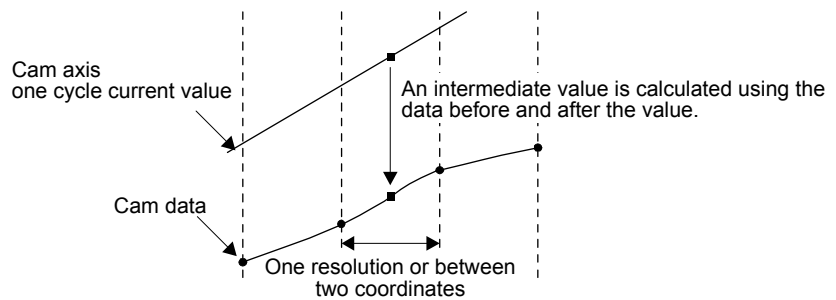

12. APPLICATION OF FUNCTIONS

2) Cam standard position

The cam standard position is calculated as follows:

Cam standard position = The preceding cam standard position + (Cam stroke amount × Stroke ratio at the last point)

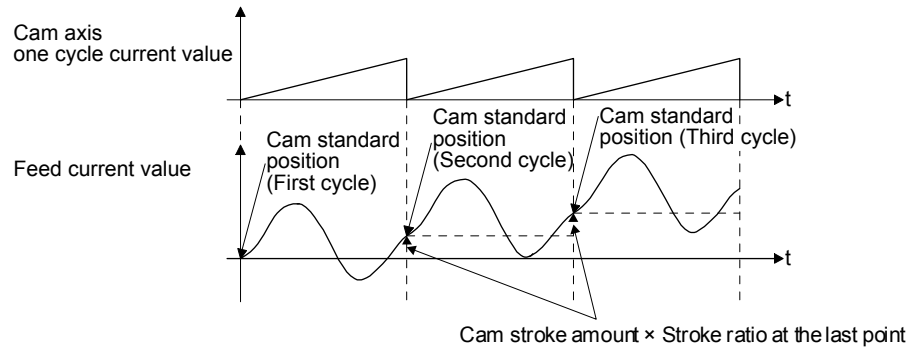

For to-and-fro control, create the cam data in which the stroke ratio at the last point is 0%.

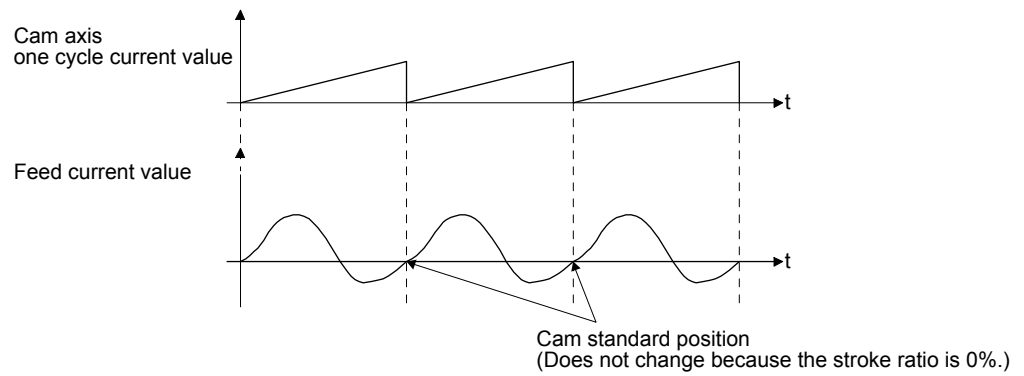

12. APPLICATION OF FUNCTIONS

3) Cam data start position

This setting is available only for the stroke ratio data type cam data.

The cam data position where the "cam axis one cycle current value" becomes "0" can be set as the cam data start position.

The initial value of the cam data start position is "0". The cam axis is controlled with the cam data from the 0th point (stroke ratio = 0%).

When a value other than "0" is set as the cam data start position, cam control is started from the point where the stroke ratio is not 0%.

Set the cam data start position for each cam data within the setting range of "0 to (Cam resolution - 1)".

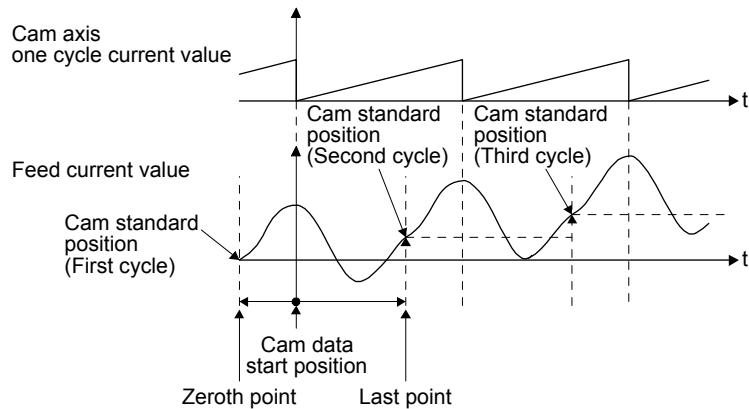

4) Timing of applying cam control data

New values are applied to "Cam No." and "Cam stroke amount" when CAMC (Cam control command) turns on.

"Cam standard position" is updated when "Cam axis one cycle current value" passes through the 0th point of the cam data.

12. APPLICATION OF FUNCTIONS

(b) Coordinate data type

The following are set in the coordinate data type. Set the following items on the cam setting window of MR Configurator2. When "Cam No." is set to "0", straight-line control is performed so that the stroke ratio at the last point of the cam data becomes 100%.

Setting item	Setting	Setting range
Cam No.	Set a Cam No.	0: Linear cam 1 to 8: User-created cam
Setting method	Set "2: Coordinate data type".	
Number of coordinate	Set the number of coordinates for the cam curve of one cycle. The number of coordinates includes 0th point.	2 to 1024
Cam data start position	Setting is not necessary.	
Coordinate data	Set the coordinate data (input value X_n and output value Y_n) for the number of coordinates. Set from the 0th coordinate data (X_0 and Y_0). Set an input value larger than that of the coordinate data.	-999.999 to 999.999

The following is a setting example for the coordinate data type.

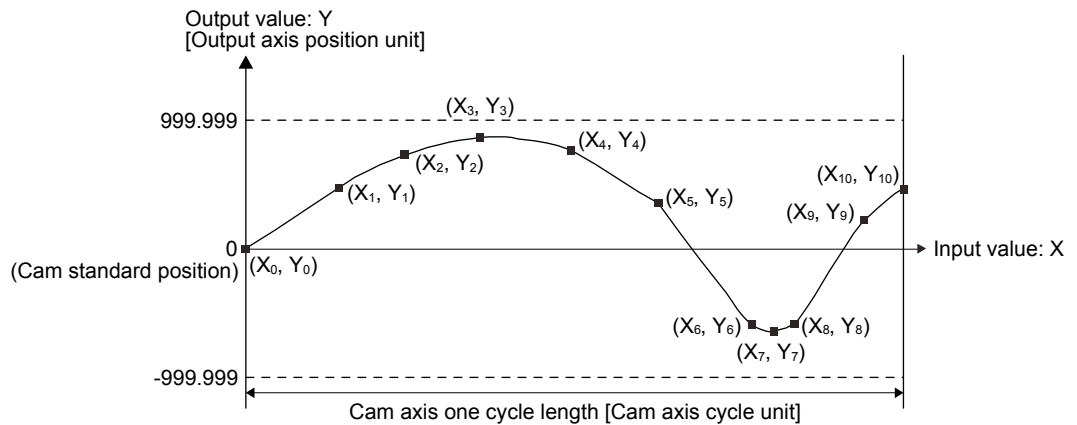

If "input value = 0" and "input value = cam axis one cycle length" are not set in the coordinate data, a control is executed by the line created from the closest two points.

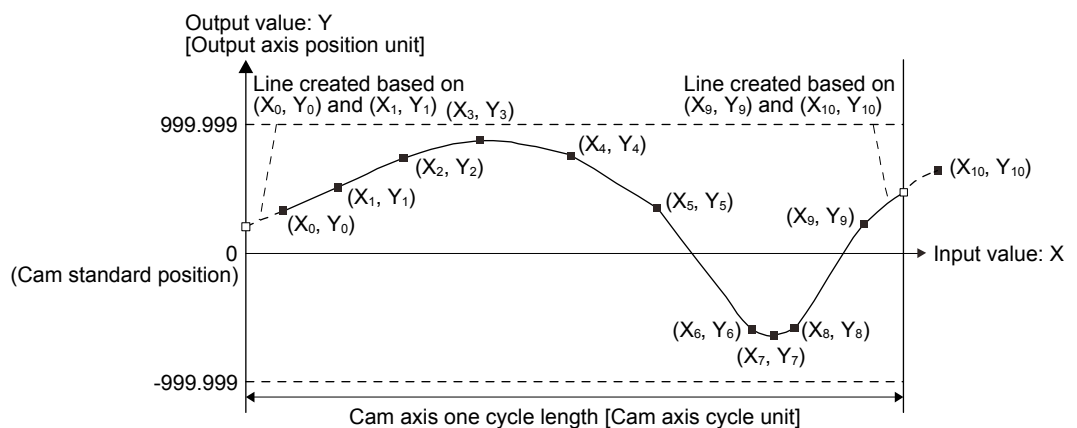

12. APPLICATION OF FUNCTIONS

1) Feed current value

The feed current value of the cam axis is calculated as follows:

Feed current value = Cam standard position + Output value to cam axis one cycle current value

When the cam axis one cycle current value is in the middle of the specified stroke ratio data, the intermediate value is calculated using the cam data before and after the value.

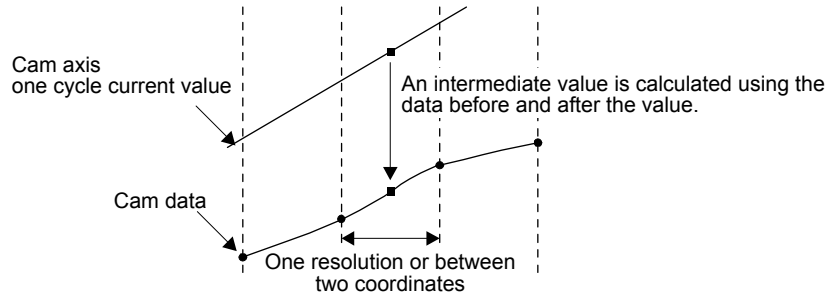

2) Cam standard position

The cam standard position is calculated as follows:

Cam standard position =

The preceding cam standard position + Output value corresponding to "Input value = Cam axis one cycle length" - Output value corresponding to "Input value = 0"

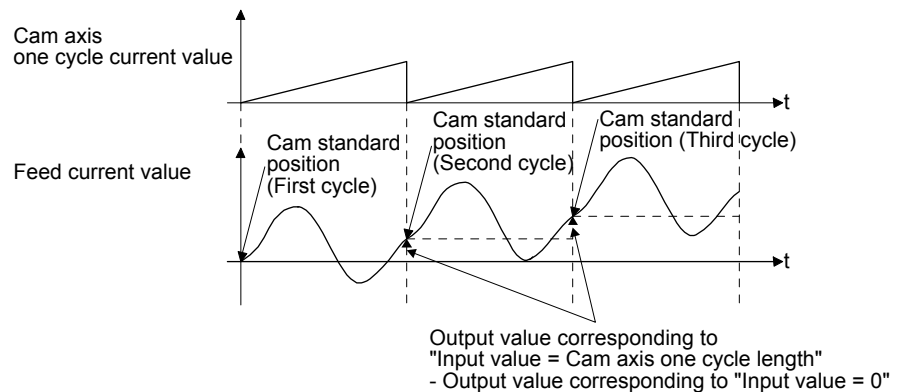

For to-and-fro control, use the output value corresponding to "Input value = Cam axis one cycle length" that is equal to output value corresponding to "Input value = 0".

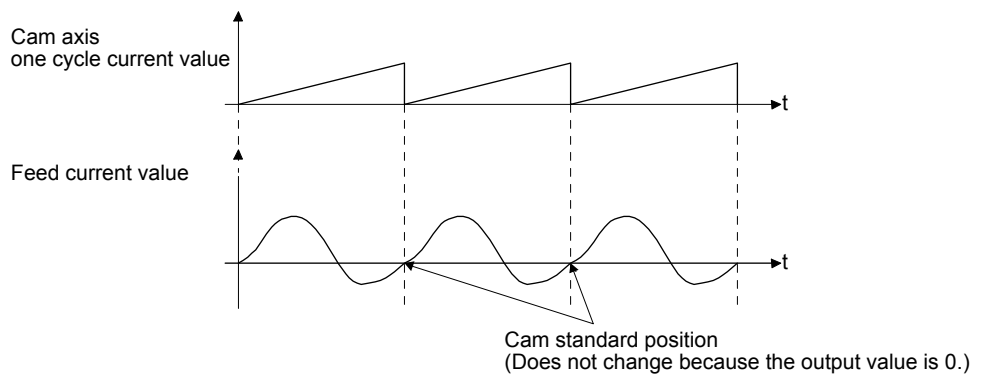

12. APPLICATION OF FUNCTIONS

3) Cam data start position

The cam data start position is not used in the coordinate data type.

4) Timing of applying cam control data

A new value is applied to "Cam No." when CAMC (Cam control command) turns on.

"Cam standard position" is updated when the cam axis one cycle current value passes through "0".

(3) List of cam control data

The following table lists the cam control data added for the simple cam function.

Set the cam control data in the cam control data window of MR Configurator2.

POINT
<ul style="list-style-type: none"> ● Once the servo amplifier is powered off, the temporarily written data will be deleted. To store the temporarily written data, be sure to write it to the Flash-ROM before powering off the servo amplifier. ● To enable the cam control data whose symbol is preceded by *, cycle the power after setting. The cam control data is not applied by the temporal writing of MR Configurator2.

No.	Symbol	Name	Initial value	Unit	Operation mode				Control mode		
					Standard	Full.	Lin.	DD	CP/BCD	CL	PS
1	MCYSM (Note)	Main axis one cycle current value setting method	0		<input type="radio"/>	<input type="radio"/>	<input type="radio"/>	<input type="radio"/>	<input type="radio"/>	<input type="radio"/>	<input type="radio"/>
2	CPRO (Note)	Cam axis position restoration target	0		<input type="radio"/>	<input type="radio"/>	<input type="radio"/>	<input type="radio"/>	<input type="radio"/>	<input type="radio"/>	<input type="radio"/>
3	CBSSM (Note)	Cam standard position setting method	0		<input type="radio"/>	<input type="radio"/>	<input type="radio"/>	<input type="radio"/>	<input type="radio"/>	<input type="radio"/>	<input type="radio"/>
4	CCYSM (Note)	Cam axis one cycle current value setting method	0		<input type="radio"/>	<input type="radio"/>	<input type="radio"/>	<input type="radio"/>	<input type="radio"/>	<input type="radio"/>	<input type="radio"/>
5	MICYS (Note)	Main axis one cycle current value (initial setting value)	0	[μm]/ 10 ⁻⁴ [inch]/ 10 ⁻³ [degree]/ [pulse]	<input type="radio"/>	<input type="radio"/>	<input type="radio"/>	<input type="radio"/>	<input type="radio"/>	<input type="radio"/>	<input type="radio"/>
6	CIBSS (Note)	Cam standard position (initial setting value)	0	[μm]/ 10 ⁻⁴ [inch]/ 10 ⁻³ [degree]/ [pulse]	<input type="radio"/>	<input type="radio"/>	<input type="radio"/>	<input type="radio"/>	<input type="radio"/>	<input type="radio"/>	<input type="radio"/>
7	CICYS (Note)	Cam axis one cycle current value (initial setting value)	0		<input type="radio"/>	<input type="radio"/>	<input type="radio"/>	<input type="radio"/>	<input type="radio"/>	<input type="radio"/>	<input type="radio"/>
8		For manufacturer setting	0		<input type="radio"/>	<input type="radio"/>	<input type="radio"/>	<input type="radio"/>	<input type="radio"/>	<input type="radio"/>	<input type="radio"/>
9			0		<input type="radio"/>	<input type="radio"/>	<input type="radio"/>	<input type="radio"/>	<input type="radio"/>	<input type="radio"/>	<input type="radio"/>
10			0		<input type="radio"/>	<input type="radio"/>	<input type="radio"/>	<input type="radio"/>	<input type="radio"/>	<input type="radio"/>	<input type="radio"/>
11			0		<input type="radio"/>	<input type="radio"/>	<input type="radio"/>	<input type="radio"/>	<input type="radio"/>	<input type="radio"/>	<input type="radio"/>
12			0		<input type="radio"/>	<input type="radio"/>	<input type="radio"/>	<input type="radio"/>	<input type="radio"/>	<input type="radio"/>	<input type="radio"/>
13			0		<input type="radio"/>	<input type="radio"/>	<input type="radio"/>	<input type="radio"/>	<input type="radio"/>	<input type="radio"/>	<input type="radio"/>
14	*ETYP	Synchronous encoder axis unit	0000h		<input type="radio"/>	<input type="radio"/>	<input type="radio"/>	<input type="radio"/>	<input type="radio"/>	<input type="radio"/>	<input type="radio"/>
15	*ECMX	Synchronous encoder axis unit conversion: Numerator	0		<input type="radio"/>	<input type="radio"/>	<input type="radio"/>	<input type="radio"/>	<input type="radio"/>	<input type="radio"/>	<input type="radio"/>
16	*ECDV	Synchronous encoder axis unit conversion: Denominator	0		<input type="radio"/>	<input type="radio"/>	<input type="radio"/>	<input type="radio"/>	<input type="radio"/>	<input type="radio"/>	<input type="radio"/>

12. APPLICATION OF FUNCTIONS

No.	Symbol	Name	Initial value	Unit	Operation mode				Control mode		
					Standard	Full.	Lin.	DD	CP/BCD	CL	PS
17		For manufacturer setting	0								
18											
19											
20											
21											
22											
23											
24											
25											
26											
27											
28											
29											
30	*MAX	Main shaft input axis selection	0			<input type="checkbox"/>	<input type="checkbox"/>	<input type="checkbox"/>	<input type="checkbox"/>	<input type="checkbox"/>	<input type="checkbox"/>
31		For manufacturer setting	0			<input type="checkbox"/>	<input type="checkbox"/>	<input type="checkbox"/>	<input type="checkbox"/>	<input type="checkbox"/>	<input type="checkbox"/>
32	MMIX	Main shaft input method	0000h			<input type="checkbox"/>	<input type="checkbox"/>	<input type="checkbox"/>	<input type="checkbox"/>	<input type="checkbox"/>	<input type="checkbox"/>
33		For manufacturer setting	0								
34											
35											
36	CLTMD	Main shaft clutch control setting	0000h			<input type="checkbox"/>	<input type="checkbox"/>	<input type="checkbox"/>	<input type="checkbox"/>	<input type="checkbox"/>	<input type="checkbox"/>
37		For manufacturer setting	0								
38											
39											
40											
41											
42	CLTSMM (Note)	Main shaft clutch smoothing system	0			<input type="checkbox"/>	<input type="checkbox"/>	<input type="checkbox"/>	<input type="checkbox"/>	<input type="checkbox"/>	<input type="checkbox"/>
43	CLTSMT (Note)	Main shaft clutch smoothing time constant	0	[ms]		<input type="checkbox"/>	<input type="checkbox"/>	<input type="checkbox"/>	<input type="checkbox"/>	<input type="checkbox"/>	<input type="checkbox"/>
44		For manufacturer setting	0								
45											
46											
47											
48	CCYL (Note)	Cam axis one cycle length	0	[μ m]/ 10^{-4} [inch]/ 10^{-3} [degree]/ [pulse]		<input type="checkbox"/>	<input type="checkbox"/>	<input type="checkbox"/>	<input type="checkbox"/>	<input type="checkbox"/>	<input type="checkbox"/>
49	CNO (Note)	Cam No.	0			<input type="checkbox"/>	<input type="checkbox"/>	<input type="checkbox"/>	<input type="checkbox"/>	<input type="checkbox"/>	<input type="checkbox"/>
50		For manufacturer setting	0			<input type="checkbox"/>	<input type="checkbox"/>	<input type="checkbox"/>	<input type="checkbox"/>	<input type="checkbox"/>	<input type="checkbox"/>
51	CSTK (Note)	Cam stroke amount	0	[μ m]/ 10^{-4} [inch]/ 10^{-3} [degree]/ [pulse]		<input type="checkbox"/>	<input type="checkbox"/>	<input type="checkbox"/>	<input type="checkbox"/>	<input type="checkbox"/>	<input type="checkbox"/>
52		For manufacturer setting	0								
53											
54											
55											
56											
57											
58											
59											

12. APPLICATION OF FUNCTIONS

No.	Symbol	Name	Initial value	Unit	Operation mode				Control mode		
					Standard	Full.	Lin.	DD	CP/BCD	CL	PS
60	CPHV	Cam position compensation target position	0	[μm]/ 10^{-4} [inch]/ 10^{-3} [degree]/ [pulse]	<input type="radio"/>	<input type="radio"/>	<input type="radio"/>	<input type="radio"/>	<input type="radio"/>	<input type="radio"/>	<input type="radio"/>
61	CPHT	Cam position compensation time constant	0	[ms]	<input type="radio"/>	<input type="radio"/>	<input type="radio"/>	<input type="radio"/>	<input type="radio"/>	<input type="radio"/>	<input type="radio"/>

Note. The data is updated at cam control switching.

(4) Detailed list of cam control data

No./symbol/name	Setting digit	Function	Initial value [unit]	Control mode		
				CP/BCD	CL	PS
1 *MCYSM Main axis one cycle current value setting method		Select a setting method for the main axis one cycle current value. 0: Previous value 1: Main axis one cycle current value (initial setting value) 2: Calculated from input axis	0	<input type="radio"/>	<input type="radio"/>	<input type="radio"/>
2 *CPRO Cam axis position restoration target		Select a target whose cam axis position is restored. 0: Cam axis one cycle current value 1: Cam standard position 2: Cam axis feed current value	0	<input type="radio"/>	<input type="radio"/>	<input type="radio"/>
3 *CBSSM Cam standard position setting method		Select a setting method for the cam standard position used to restore the cam axis one cycle current value. 0: Feed current value 1: Cam standard position (initial setting value) 2: Previous value The cam standard position of the last cam control is stored in the previous value. The feed current value is stored when the cam standard position of the last cam control has not been saved. Turning off the power clears the previous value.	0	<input type="radio"/>	<input type="radio"/>	<input type="radio"/>
4 *CCYSM Cam axis one cycle current value setting method		Select a setting method for the cam axis one cycle current value used for restoration when "Cam standard position" and "Cam axis feed current value" have been set as the cam axis position restoration targets. 0: Previous value 1: Cam axis one cycle current value (initial setting value) 2: Main axis one cycle current value The cam axis one cycle current value of the last cam control is stored in the previous value. Turning off the power clears the previous value.	0	<input type="radio"/>	<input type="radio"/>	<input type="radio"/>
5 *MICYS Main axis one cycle current value (initial setting value)		Set the initial value of the main axis one cycle current value. • When [Cam control data No. 30] is set to "1" The unit will be changed to [μm], 10^{-4} [inch], 10^{-3} [degree], or [pulse] with the setting of [Pr. PT01]. • When [Cam control data No. 30] is set to "2" The unit will be changed to [μm], 10^{-4} [inch], 10^{-3} [degree], or [pulse] with the setting of [Cam control data No. 14]. Setting range: 0 to [Cam control data No. 48] - 1	0 Refer to Function column for unit.	<input type="radio"/>	<input type="radio"/>	<input type="radio"/>

12. APPLICATION OF FUNCTIONS

No./symbol/name	Setting digit	Function	Initial value [unit]	Control mode		
				CP/BCD	OL	PS
6 *CIBSS Cam standard position (initial setting value)		This is enabled when [Cam control data No. 3] is set to "1". Set the initial value of the cam standard position in the output axis position unit. The unit will be changed to [μm], 10 ⁻⁴ [inch], 10 ⁻³ [degree], or [pulse] with the setting of [Pr. PT01]. Setting range: -999999 to 999999	0 Refer to Function column for unit.	<input type="radio"/>	<input type="radio"/>	
7 *CICYS Cam axis one cycle current value (initial setting value)		Set the position to start the search processing to restore the cam axis one cycle current value. Set this item when restoring the position of the return path with the to-and-fro control cam pattern. <ul style="list-style-type: none"> When [Cam control data No. 30] is set to "1" The unit will be changed to [μm], 10⁻⁴ [inch], 10⁻³ [degree], or [pulse] with the setting of [Pr. PT01]. When [Cam control data No. 30] is set to "2" The unit will be changed to [μm], 10⁻⁴ [inch], 10⁻³ [degree], or [pulse] with the setting of [Cam control data No. 14]. Setting range: 0 to [Cam control data No. 48] - 1	0 Refer to Function column for unit.	<input type="radio"/>	<input type="radio"/>	
14 *ETYP Synchronous encoder axis unit	___x	Control unit 0: mm 1: inch 2: degree 3: pulse	0h	<input type="radio"/>	<input type="radio"/>	
	__x_	Feed length multiplication 0: × 1 1: × 10 2: × 100 3: × 1000 This digit is disabled when [Cam control data No. 14] is set to "___2" or "___3".	0h	<input type="radio"/>	<input type="radio"/>	
	_x__	For manufacturer setting	0h	<input type="radio"/>	<input type="radio"/>	
	x___		0h	<input type="radio"/>	<input type="radio"/>	
15 *ECMX Synchronous encoder axis unit conversion: Numerator		Set a numerator used to convert encoder pulses of the synchronous encoder axis into the synchronous encoder axis unit. Set the numerator within the following range. $\frac{1}{16000} \leq \frac{\text{ECMX}}{\text{ECDV}} \leq 6000$ Setting a value out of the range will trigger [AL. F6 Cam control warning]. When "0" is set, handle the numerator in the same way as when "1" is set. Setting range: 0 to 16777215	0	<input type="radio"/>	<input type="radio"/>	
16 *ECDV Synchronous encoder axis unit conversion: Denominator		Set a denominator used to convert encoder pulses of the synchronous encoder axis into the synchronous encoder axis unit. Set a value within the range of [Cam control data No. 15]. Setting a value out of the range will trigger [AL. F6 Cam control warning]. When "0" is set, handle the denominator in the same way as when "1" is set. Setting range: 0 to 16777215	0	<input type="radio"/>	<input type="radio"/>	
30 *MAX Main shaft input axis selection		Select an input axis of the main shaft input. 0: Disabled 1: Servo input axis 2: Synchronous encoder axis	0	<input type="radio"/>	<input type="radio"/>	

12. APPLICATION OF FUNCTIONS

No./symbol/name	Setting digit	Function	Initial value [unit]	Control mode		
				CP/BCD	CL	PS
32 *MMIX Main shaft input method	___x	Main input method 0: Input + 1: Input - 2: No input	0h	<input type="radio"/>	<input type="radio"/>	<input type="radio"/>
	__x_	For manufacturer setting	0h	<input type="radio"/>	<input type="radio"/>	<input type="radio"/>
	_x__		0h	<input type="radio"/>	<input type="radio"/>	<input type="radio"/>
	x___		0h	<input type="radio"/>	<input type="radio"/>	<input type="radio"/>
36 *CLTMD Main shaft clutch control setting	___x	ON control mode 0: No clutch 1: Clutch command ON/OFF	0h	<input type="radio"/>	<input type="radio"/>	<input type="radio"/>
	__x_	For manufacturer setting	0h	<input type="radio"/>	<input type="radio"/>	<input type="radio"/>
	_x__		0h	<input type="radio"/>	<input type="radio"/>	<input type="radio"/>
	x___		0h	<input type="radio"/>	<input type="radio"/>	<input type="radio"/>
42 *CLTSMM Main shaft clutch smoothing system		Select a clutch smoothing system. 0: Direct 1: Time constant method (index)	0	<input type="radio"/>	<input type="radio"/>	<input type="radio"/>
43 *CLTSMT Main shaft clutch smoothing time constant		This is enabled when [Cam control data 42] is set to "1". Set the smoothing time constant. Setting range: 0 to 5000	0 [ms]	<input type="radio"/>	<input type="radio"/>	<input type="radio"/>
48 *CCYL Cam axis one cycle length		Set an input amount required for cam one cycle. • When [Cam control data No. 30] is set to "0" or "1" The unit will be changed to [μm], 10 ⁻⁴ [inch], 10 ⁻³ [degree], or [pulse] with the setting of [Pr. PT01]. • When [Cam control data No. 30] is set to "2" The unit will be changed to [μm], 10 ⁻⁴ [inch], 10 ⁻³ [degree], or [pulse] with the setting of [Cam control data No. 14]. Setting range: 0 to 999999	0 Refer to Function column for unit.	<input type="radio"/>	<input type="radio"/>	<input type="radio"/>
49 *CNO Cam No.		Set the cam No. of the cam to be executed. When "0" is set, the selections of the input devices C10 to C13 will be prioritized. When a value other than "0" is set, the selections of the input devices C10 to C13 will be disabled. Setting range: 0 to 8	0	<input type="radio"/>	<input type="radio"/>	<input type="radio"/>
51 *CSTK Cam stroke amount		Set a cam stroke amount for the stroke ratio of 100% when using the stroke ratio data type cam. The unit will be changed to [μm], 10 ⁻⁴ [inch], 10 ⁻³ [degree], or [pulse] with the setting of [Pr. PT01]. Setting range: -999999 to 999999	0 Refer to Function column for unit.	<input type="radio"/>	<input type="radio"/>	<input type="radio"/>
60 *CPHV Cam position compensation target position		Set a compensation target position to the input axis of the cam axis. Set the mark sensor position with the cam axis one cycle current value. • When [Cam control data No. 30] is set to "1" The unit will be changed to [μm], 10 ⁻⁴ [inch], 10 ⁻³ [degree], or [pulse] with the setting of [Pr. PT01]. • When [Cam control data No. 30] is set to "2" The unit will be changed to [μm], 10 ⁻⁴ [inch], 10 ⁻³ [degree], or [pulse] with the setting of [Cam control data No. 14]. Setting range: 0 to [Cam control data No. 48] - 1	0 Refer to Function column for unit.	<input type="radio"/>	<input type="radio"/>	<input type="radio"/>

12. APPLICATION OF FUNCTIONS

No./symbol/name	Setting digit	Function	Initial value [unit]	Control mode		
				CP/BCD	CP	PS
61 *CPHT Cam position compensation time constant		Set the time to apply the position compensation for the input axis of the cam axis. Setting range: 0 to 65535	0 [ms]	<input type="radio"/>	<input type="radio"/>	

12. APPLICATION OF FUNCTIONS

- (a) Relation among the main shaft input axis, position data unit, and feed length multiplication setting
The parameters used to set the position data unit and feed length multiplication differ depending on the setting of [Cam control data No. 30 Main shaft input axis selection].

Item		Main shaft input axis selection ([Cam control data No. 30])		
		0 (Disabled)	1 (Servo input axis)	2 (Synchronous encoder axis)
Main axis one cycle current value setting method ([Cam control data No. 5])	Unit	[Pr. PT01]	[Pr. PT01]	[Cam control data No. 14]
	Multiplication	[Pr. PT03]	[Pr. PT03]	
Cam standard position (initial setting value) ([Cam control data No. 6])	Unit	[Pr. PT01]	[Pr. PT01]	[Pr. PT01]
	Multiplication	[Pr. PT03]	[Pr. PT03]	[Pr. PT03]
Cam axis one cycle current value (initial setting value) ([Cam control data No. 7])	Unit	[Pr. PT01]	[Pr. PT01]	[Cam control data No. 14]
	Multiplication	[Pr. PT03]	[Pr. PT03]	
Synchronous encoder axis unit conversion: Numerator ([Cam control data No. 15])	Unit	[Pr. PT01]	[Pr. PT01]	
	Multiplication	[Pr. PT03]	[Pr. PT03]	
Synchronous encoder axis unit conversion: Denominator ([Cam control data No. 16])	Unit	[Pr. PT01]	[Pr. PT01]	
	Multiplication	[Pr. PT03]	[Pr. PT03]	
Cam axis one cycle length ([Cam control data No. 48])	Unit	[Pr. PT01]	[Pr. PT01]	
	Multiplication	[Pr. PT03]	[Pr. PT03]	
Cam stroke amount ([Cam control data No. 51])	Unit	[Pr. PT01]	[Pr. PT01]	[Pr. PT01]
	Multiplication	[Pr. PT03]	[Pr. PT03]	[Pr. PT03]
Cam position compensation amount ([Cam control data No. 60])	Unit	[Pr. PT01]	[Pr. PT01]	[Cam control data No. 14]
	Multiplication	[Pr. PT03]	[Pr. PT03]	

- (b) Synchronous encoder axis unit conversion gear setting

The input travel amount of the synchronous encoder is in encoder pulse units. You can convert the unit into a desired unit through unit conversion by setting [Cam control data No. 15 Synchronous encoder axis unit conversion: Numerator] and [Cam control data No. 16 Synchronous encoder axis unit conversion: Denominator].

Set [Cam control data No. 15] and [Cam control data No. 16] according to the control target machine.

$$\begin{array}{l} \text{Synchronous encoder} \\ \text{axis travel distance} \\ \text{(after unit conversion)} \end{array} = \begin{array}{l} \text{Synchronous encoder} \\ \text{input travel distance} \\ \text{(encoder pulse unit)} \end{array} \times \frac{[\text{Cam control data No. 15}]}{[\text{Cam control data No. 16}]}$$

The travel distance (number of pulses) set in [Cam control data No. 16] is set in [Cam control data No. 15] in synchronous encoder axis position units.

Set [Cam control data No. 16] in encoder pulse units of the synchronous encoder.

12. APPLICATION OF FUNCTIONS

(5) Modbus register

The following explains the main registers for the Modbus-RTU communications used by the simple cam function. Refer to "MR-J4-_A_-RJ Servo Amplifier Instruction Manual (Modbus-RTU communication)" for the registers not described in this section.

(a) Related registers

Address	Name	Data type	Read/write	No. of points/ No. of Registers	Continuous read/ continuous write
2D80h	Target CAM No.	1 byte	Read/write	1	Impossible
2D82h	CAM actual No.	1 byte	Read	1	Impossible
2D84h	One cycle length of CAM axis	4 bytes	Write	2	Impossible
2D85h	Stroke movement of CAM	4 bytes	Write	2	Impossible
2D88h	Request store CAM	1 byte	Write	1	Impossible
2D89h	CAM area	2 bytes	Read/write	1	Impossible
2D8Bh	CAM data in CAM area	64 bytes	Read/write	32	Impossible

(b) Details of registers

1) Cam number setting (2D80h)

Address	Name	Data type	Read/write	No. of points/ No. of Registers	Continuous read/ continuous write
2D80h	Target CAM No.	1 byte	Read/write	1	Impossible

A cam number can be read using the function code "03h" (Read Holding Registers).

A cam number can be set using the function code "10h" (Preset Multiple Registers).

If [Cam control data No. 49 - Cam No.] is "0", the cam number set with this register is enabled.

If the cam number is not "0", the setting of [Cam control data No. 49] is enabled and this register is disabled.

2) Current cam number (2D82h)

Address	Name	Data type	Read/write	No. of points/ No. of Registers	Continuous read/ continuous write
2D82h	CAM actual No.	1 byte	Read	1	Impossible

While a cam control operation is being performed (when "1" is set in bit 5 of 2D12h), the cam number being used in the operation can be read using the function code "03h" (Read Holding Registers).

12. APPLICATION OF FUNCTIONS

3) Cam axis one cycle length setting (2D84h)

Address	Name	Data type	Read/write	No. of points/ No. of Registers	Continuous read/ continuous write
2D84h	One cycle length of CAM axis	4 bytes	Write	2	Impossible

The cam axis one cycle length can be written in the RAM space in the servo amplifier using the function code "10h" (Preset Multiple Registers).

The values set with this register are deleted at power-off.

4) Cam stroke length setting (2D85h)

Address	Name	Data type	Read/write	No. of points/ No. of Registers	Continuous read/ continuous write
2D85h	Stroke movement of CAM	4 bytes	Write	2	Impossible

A cam stroke length can be written in the RAM space in the servo amplifier using the function code "10h" (Preset Multiple Registers).

The values set with this register are deleted at power-off.

5) Request store CAM (2D88h)

Address	Name	Data type	Read/write	No. of points/ No. of Registers	Continuous read/ continuous write
2D88h	Request store CAM	1 byte	Write	1	Impossible

Cam data can be written in the RAM space in the servo amplifier using the function code "10h" (Preset Multiple Registers). Always set "0" in this register.

The values set with this register are deleted at power-off.

12. APPLICATION OF FUNCTIONS

6) CAM area (2D89h)

Address	Name	Data type	Read/write	No. of points/ No. of Registers	Continuous read/ continuous write
2D89h	CAM area	2 bytes	Read/write	1	Impossible

The storage area of cam data to be read or written can be set using the function code "10h" (Preset Multiple Registers).

The following table shows the relation between a value set in this register and cam data storage area.

Setting value	Cam data storage area [byte]
0	0 to 63
1	64 to 127
2	128 to 191
.	.
.	.
.	.
130	8320 to 8383
131	8384 to 8447 (Note)

Note. Data of up to 8388 bytes can be stored in the cam data storage area. The value "0" is stored in the 8388th cam data storage area or later.

7) CAM data in CAM area (2D8Bh)

Address	Name	Data type	Read/write	No. of points/ No. of Registers	Continuous read/ continuous write
2D8Bh	CAM data in CAM area	64 bytes	Read/write	32	Impossible

Cam data in the area specified with CAM area (2D89h) can be read using the function code "03h" (Read Holding Registers).

Cam data can be written in the RAM space in the servo amplifier using the function code "10h" (Preset Multiple Registers).

Specify the space in which cam data is written with the CAM area (2D89h).

12. APPLICATION OF FUNCTIONS

(6) How to use Modbus-RTU communication

When using cam data for the maximum number of registrations or more, save the cam data in the controller with the following method. By writing the stored cam data from the controller, the user can use the cam data for the maximum number of registrations or more.

However, note the following restrictions.

- The cam data written from the controller cannot be read with MR Configurator2.
- Write the cam data and the cam control data in the servo-off state and when CAMC (Cam control command) is off.

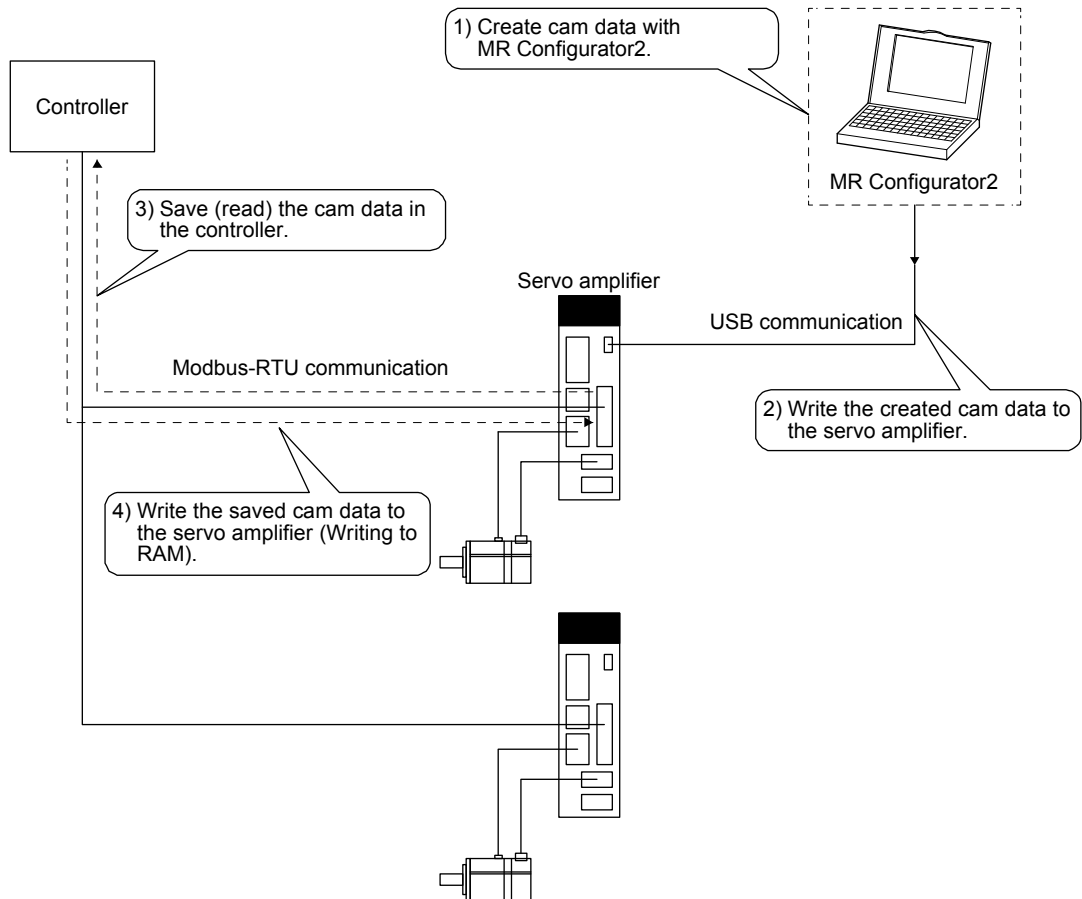

The cam No., cam axis one cycle length, and cam stroke amount of the cam control data can be written to the servo amplifier from the controller. Set them using Cam number setting (2D80h), Cam axis one cycle length setting (2D84h), and Cam stroke length setting (2D85h). Refer to section 12.1.7 (1) for the cam control data.

12. APPLICATION OF FUNCTIONS

(a) Reading

Since cam data is 8 Kbytes, the cam data is divided by 64 bytes and read via Modbus-RTU communication. The following shows the procedure for reading cam data with the register addresses 2D88h, 2D89h, and 2D8Bh.

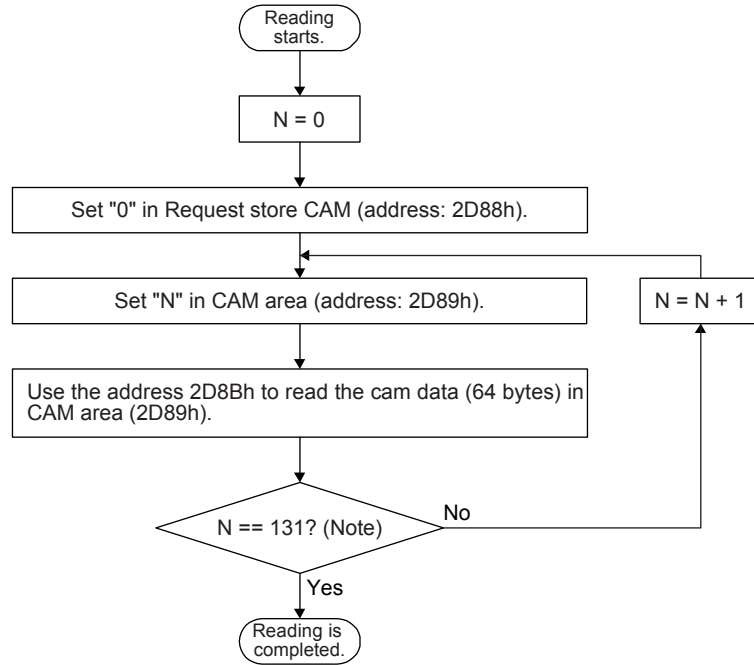

Note. The size of cam data is fixed to 8388 bytes. Thus, N, the setting range of the cam storage area is 0 to 131. Only a part of cam data cannot be read. Read the cam data stored in all areas.

12. APPLICATION OF FUNCTIONS

(b) Writing

Since cam data is 8 Kbytes, the cam data is divided by 64 bytes and written via Modbus-RTU communication. The following shows the procedure for writing cam data with the register addresses 2D88h, 2D89h, and 2D8Bh.

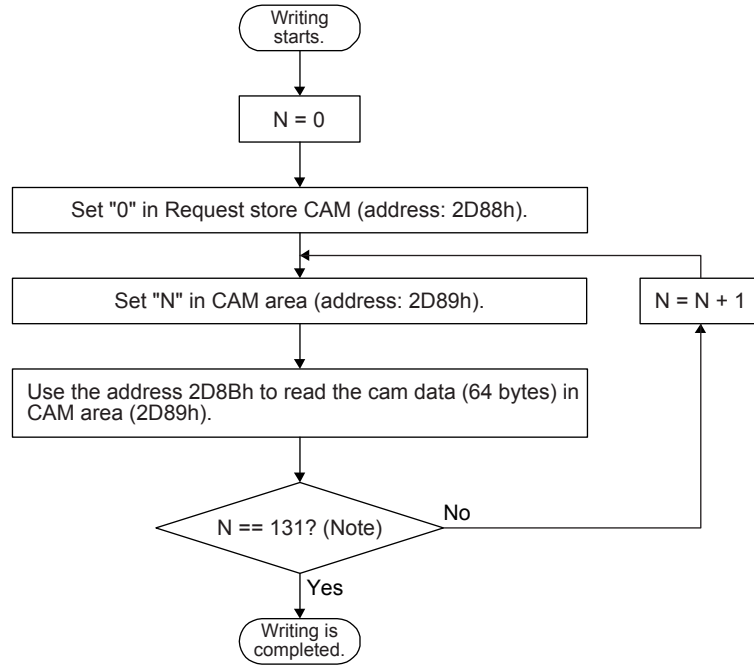

Note. The size of cam data is fixed to 8388 bytes. Thus, N, the setting range of the cam storage area is 0 to 131. Only a part of cam data cannot be written. Write the cam data stored in all areas.

12. APPLICATION OF FUNCTIONS

12.1.8 Function block diagram for displaying state of simple cam control

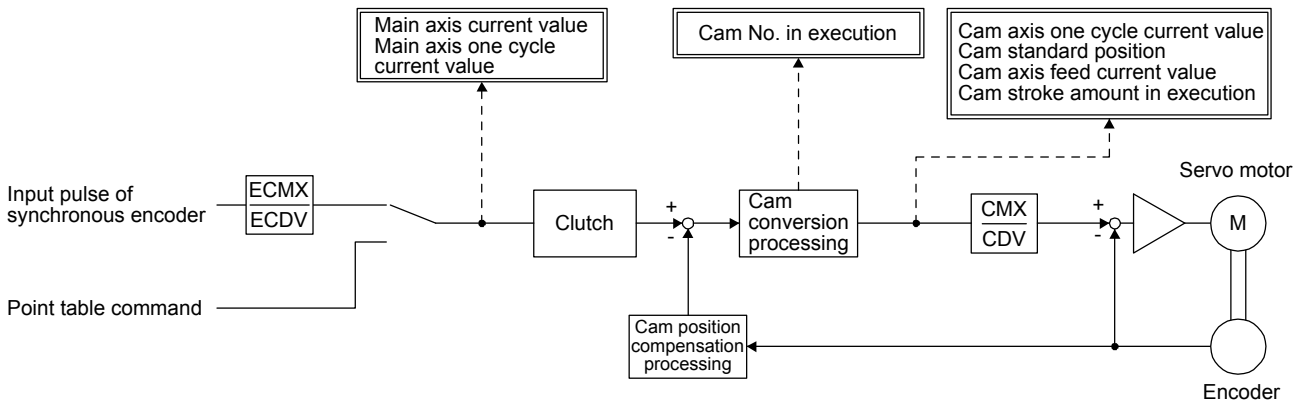

12.1.9 Operation

This section explains an operation using the simple cam function with concrete examples.

(1) Example of a rotary knife device

(a) Configuration example

The rotary knife cuts the sheet conveyed by the conveyor at a constant speed into a desired length. To prevent variations in the sheet length and a cutting position mismatch, this device reads registration marks that have been printed on the sheet, and compensates cutting positions.

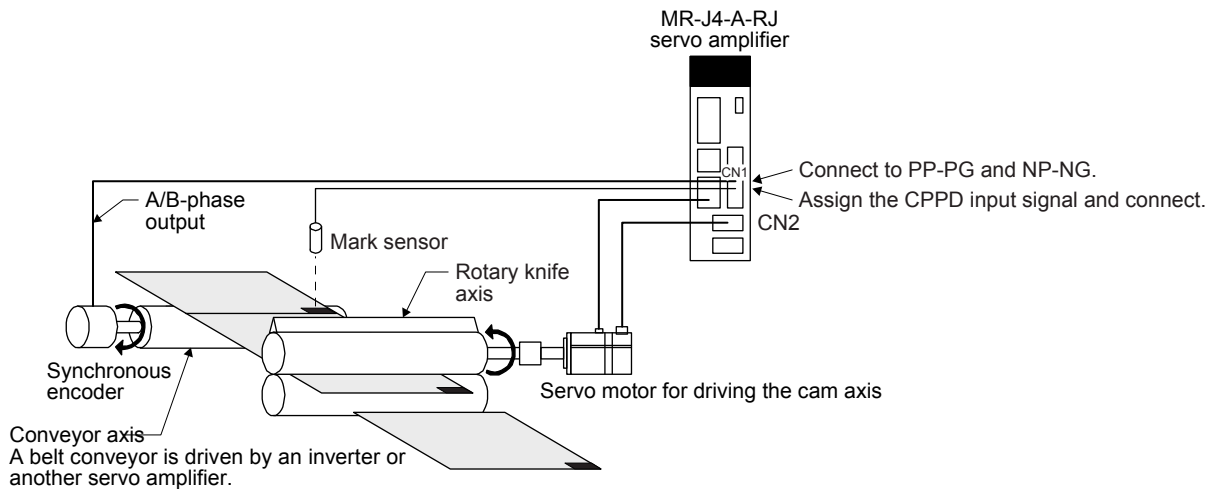

Fig. 12.1.1 System configuration example

12. APPLICATION OF FUNCTIONS

Setting example: When the sheet length is 200.0 mm, the circumferential length of the rotary knife axis (synchronous axis length) is 600.0 mm, and the sheet synchronous width is 10.0 mm

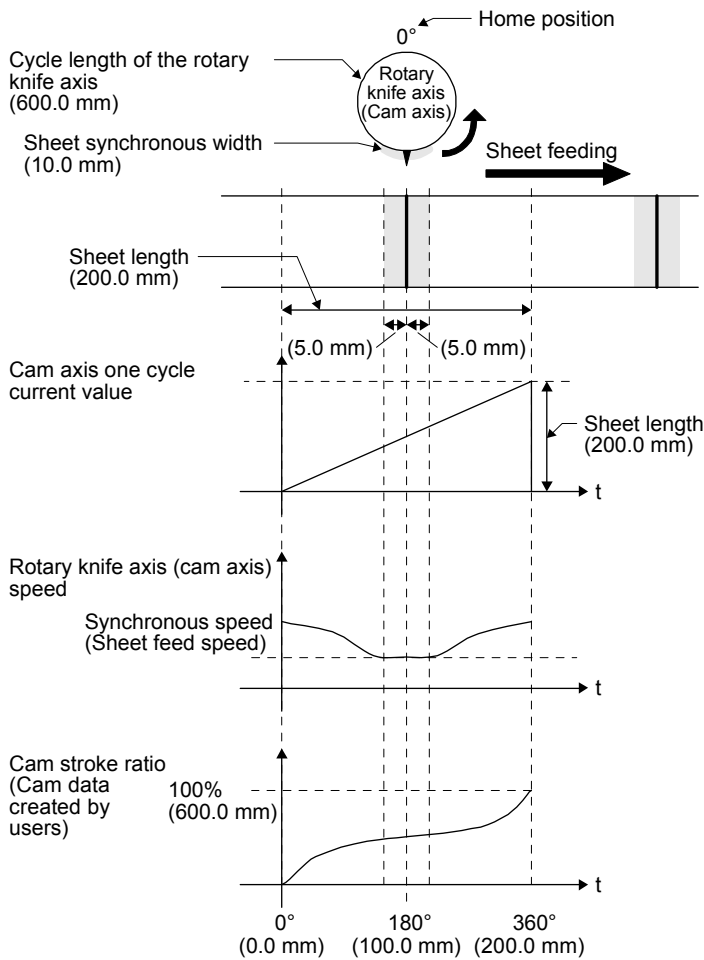

Fig. 12.1.2 Driving example

Basic settings require to use the simple cam function

Item	Setting	Setting value
Operation mode selection ([Pr. PA01])	Select "Point table method".	"1006"
Simple cam function setting ([Pr. PT35])	Enable the simple cam function.	"_ 1 _"
Device setting	Assign CAMC (Cam control command input), CAMS (Output in cam control), and CI0 to CI3 (Cam No. selection 0 to 3) with I/O setting parameters ([Pr. PD_ _]).	Refer to section 7.2.4.

When the conveyor axis (main axis) feeds a sheet by the set length, the rotary knife makes one rotation (360 degrees) to cut the sheet. Set the following items as follows.

Item	Setting	Setting value
Cam axis one cycle length ([Cam control data No. 48])	Set the sheet length.	200.000
Cam stroke amount ([Cam control data No. 51])	Set the rotation amount per rotation in "degree".	360.000
Synchronous encoder axis unit ([Cam control data No. 14])	Set the unit of the sheet length.	0 (mm)
Unit of rotary knife axis ([Pr. PT01])	Set "degree" as the unit of position data.	"_ 2 _"
Cam data	Create the cam data with the operation pattern shown in Fig. 12.1.2.	

Set the following items as follows to use the encoder following function.

Item	Setting	Setting value
Main shaft input axis selection ([Cam control data No. 30])	Select the synchronous encoder axis.	2
Synchronous encoder axis unit multiplication: Numerator ([Cam control data No. 15])	Refer to the synchronous encoder axis unit conversion gear setting in section 12.1.7 (3) (b).	Refer to section 12.1.7 (3) (b).
Synchronous encoder axis unit multiplication: Denominator ([Cam control data No. 16])		

12. APPLICATION OF FUNCTIONS

(b) Operation

The following table shows an example of the procedure before operation.

Step	Setting and operation
1. Data setting	Refer to the setting example on the previous page and set the data.
2. Initial position adjustment	Adjust the synchronous positions of the conveyor axis and rotary knife axis. <ul style="list-style-type: none"> When the position of the conveyor axis (main axis current value) is "0", set the position of the rotary knife axis (feed current value) to "0". Since the position at power-on is "0", the home position return of the conveyor axis is not required. Perform the home position return on the rotary knife axis at the point where the blade of the cutter becomes the top. Adjust the conveyor axis and rotary knife axis so that the 0 position of both axes is located at the center of the sheet length.
3. Selecting cam data	Select the cam data to be executed with CI0 to CI3 (Cam No. selection 0 to 3). The user can use [Cam control data No. 49 - Cam No.] to select the cam data. (Note 1)
4. Servo-on	Switch on SON (Servo-on).
5. Switching cam control	Switch on CAMC (Cam control command) to switch the control to the cam control. (Note 2)
6. Starting the conveyor axis	Check that CAMS (During cam control) is on and start the conveyor axis. (Note 2) The rotary knife axis is driven in synchronization with the conveyor axis.

- Note 1. Use Cam number setting (2D80h) to select a cam No. via the Modbus-RTU communication.
 Note 2. Use C_CAMC (Control input (bit 5 of 2D02h)) to input a cam control command via the Modbus-RTU communication. The output status during cam control can be read with S_CAMS (Control output (bit 5 of 2D12h)).

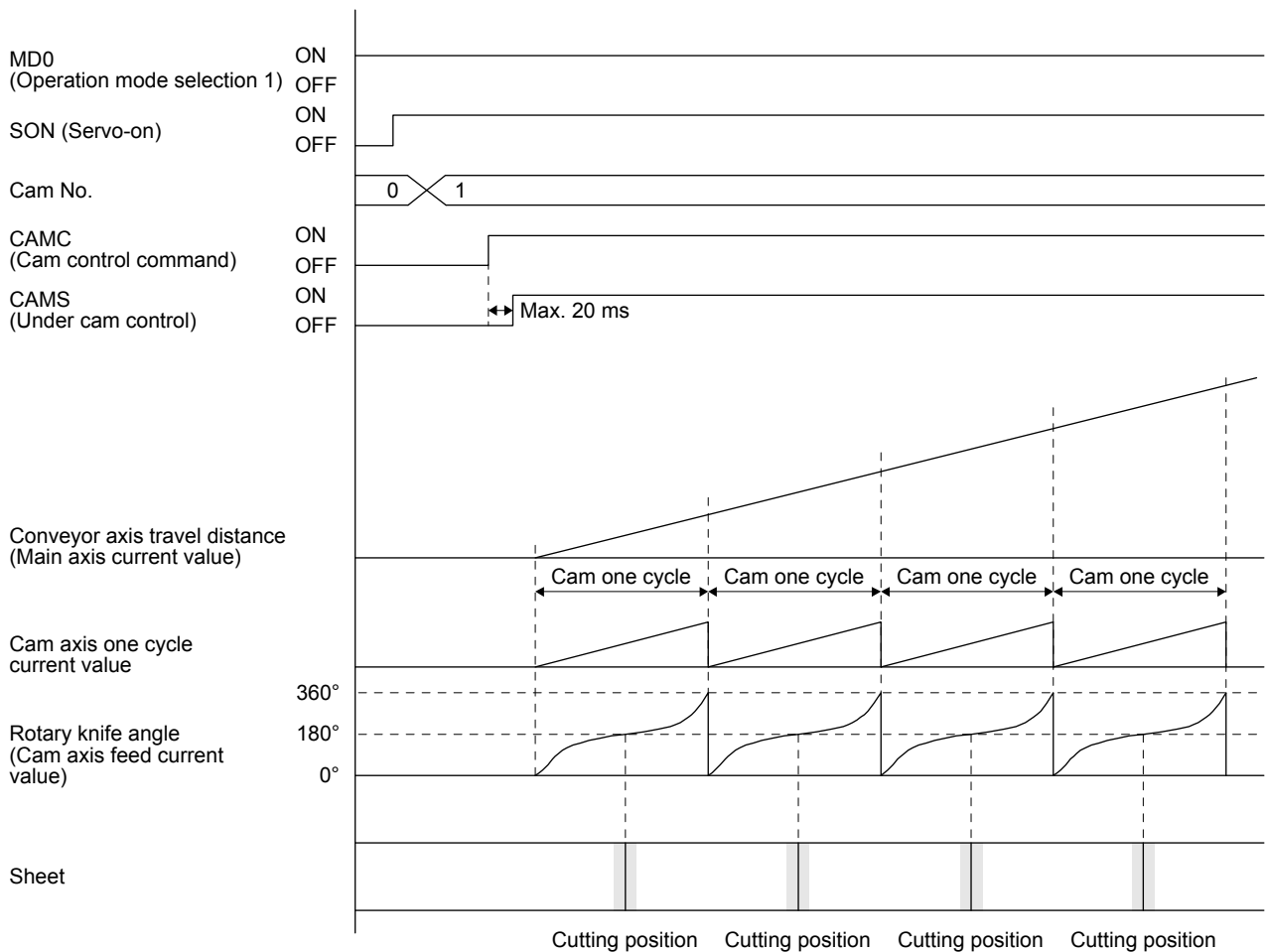

Fig. 12.1.3 Timing chart

12. APPLICATION OF FUNCTIONS

(c) Compensation with mark sensor input

This system detects registration marks that have been equally printed on the sheet, and compensates the difference between the actual cam axis one cycle current value and the ideal cam axis one cycle current value (set value of the cam position compensation target position) by shifting the synchronous phase of the rotary knife axis and the conveyor axis.

Setting example: When the ideal registration mark position is 150 mm and the mark is not detected unless the conveyor feeds the sheet by 151 mm due to stretch
By executing compensation, the rotary knife cuts the sheet keeping the distance of 50 mm between the ideal position for detecting the registration mark and the position for cutting the sheet.

Item	Setting and operation
Assignment of CPCD (Cam position compensation request)	Assign "CPCD" for an input signal pin with the input device selection parameter. Refer to section 7.2.4 for details.
Cam position compensation target position ([Cam control data No. 60])	In this example, the ideal position for detecting the registration mark is 150 mm position from the cam axis one cycle current value. Set "150" for the cam position compensation target position.
Cam position compensation time constant ([Cam control data No. 61])	In this example, the position compensation is executed by one-shot. Set "0" for the cam position compensation time constant.

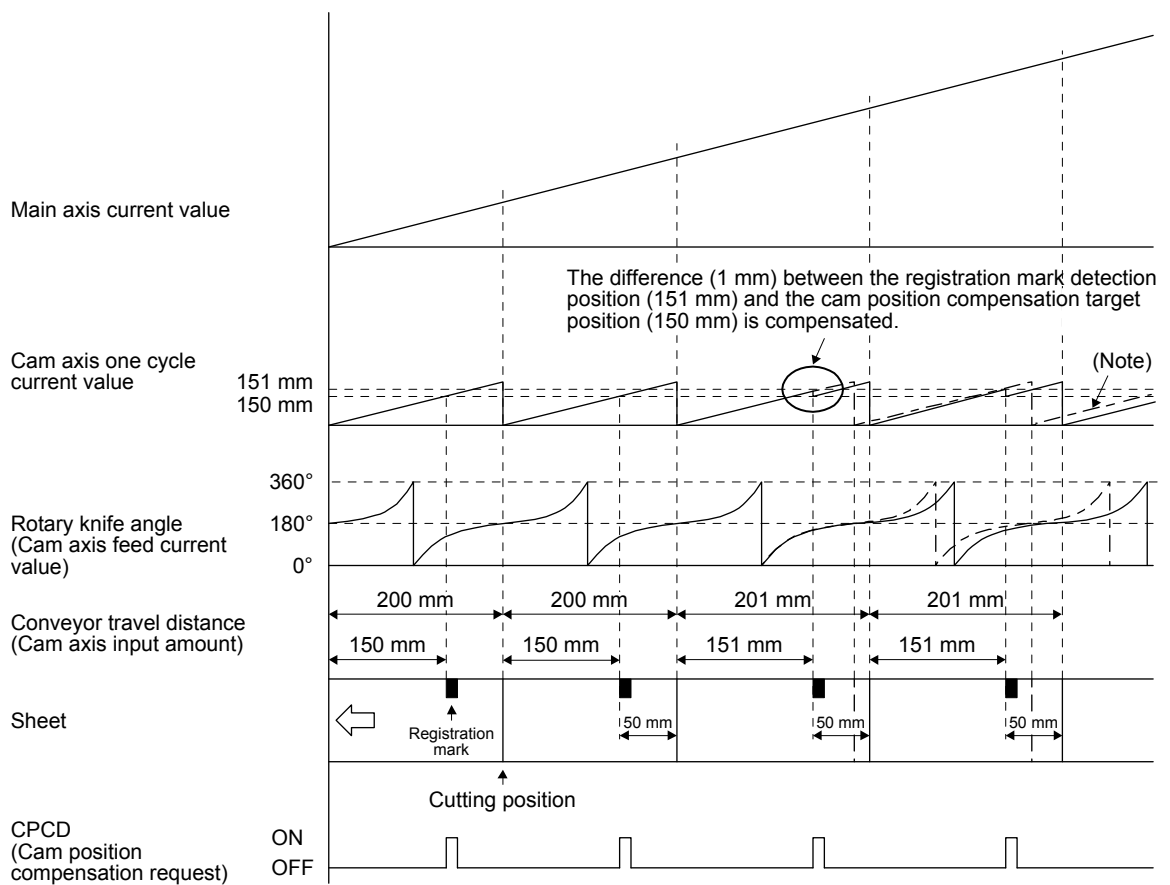

Note. The dot-and-dash line in the above figure shows a waveform of when compensation is not executed.

Fig. 12.1.4 Control example of cam position compensation

12. APPLICATION OF FUNCTIONS

(d) Details of cam position compensation

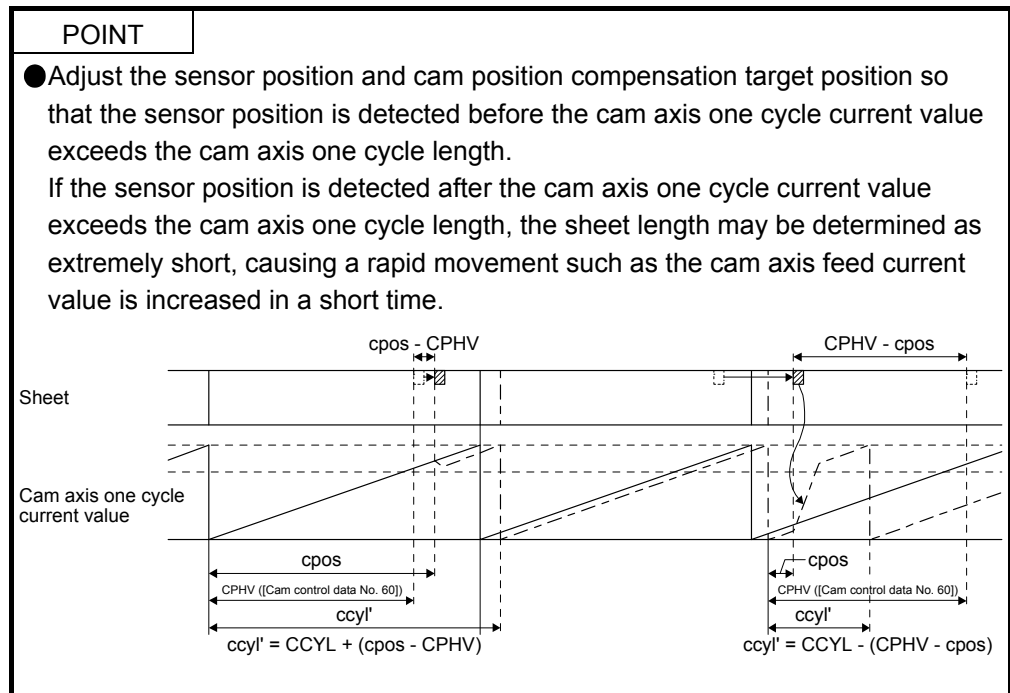

The cam position compensation processing compensates the difference between the target position for detecting the sensor and the actual position for detecting the sensor by shifting the cam axis one cycle current value. $ccyl'$, the cam axis one cycle length (sheet length) after compensation, is calculated as follows:

CCYL: Cam axis one cycle length ([Cam control data No. 48])

CPHV: Cam position compensation target position ([Cam control data No. 60])

$ccyl'$: Cam axis one cycle length (after compensation)

$cpos$: Cam axis one cycle current value at sensor detection

$CPHV - cpos$: Distance between the target sensor detection position and actual sensor detection position

12. APPLICATION OF FUNCTIONS

- When the sensor detection position is before the target position ($CPHV \geq cpos$): $ccyl' = CCYL - (CPHV - cpos)$

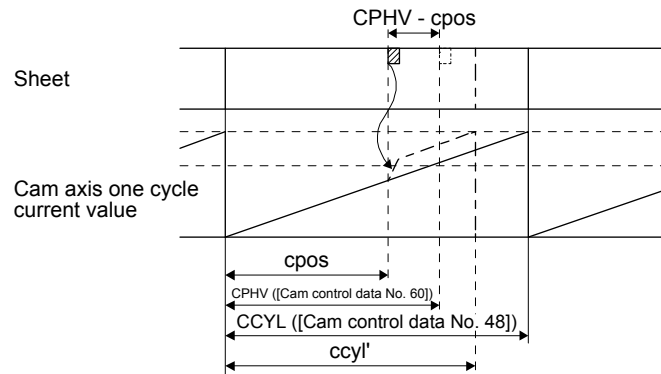

Increase the conveyor travel distance by adding the difference ($CPHV - cpos$) to the cam axis one cycle current value. Adjust the filter time constant for acceleration/deceleration at compensation with [Cam control data No. 61 Cam position compensation time constant].

- When the sensor detection position is after the target position ($CPHV < cpos$): $ccyl' = CCYL + (cpos - CPHV)$

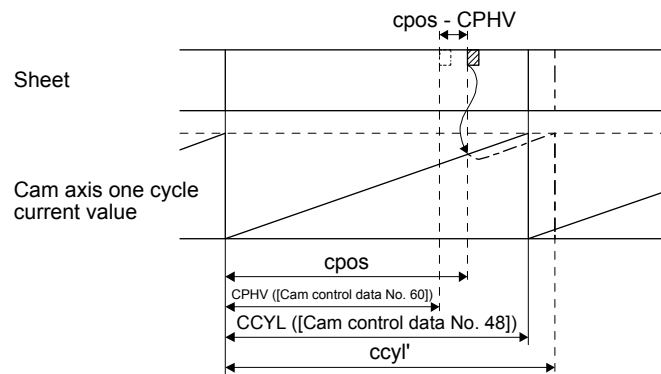

Decrease the conveyor travel distance by subtracting the difference ($cpos - CPHV$) from the cam axis one cycle current value. Adjust the filter time constant for acceleration/deceleration at compensation with [Cam control data No. 61 Cam position compensation time constant].

12. APPLICATION OF FUNCTIONS

(2) Example of the simultaneous start function with contact input or via the Modbus-RTU communication

(a) Configuration example

To synchronize the vertical motion of the vertical axis (axis 2) with the position of the horizontal axis (axis 1) as shown below, input the positioning commands for axis 1 to axis 2 as well. (Set the same point table data for the axis 1 and 2.)

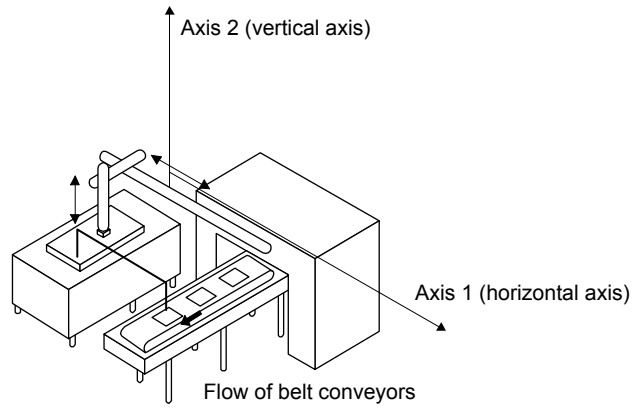
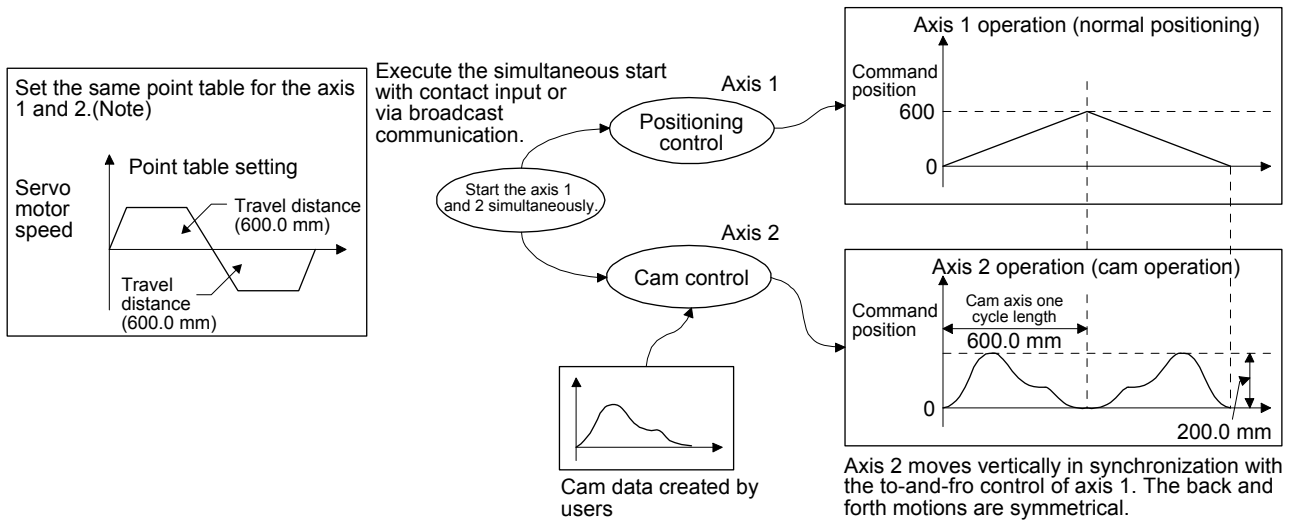

Fig. 12.1.5 System configuration example

12. APPLICATION OF FUNCTIONS

Setting example: When the movable range of the axis 1 (horizontal axis) is 600.0 mm and the axis 2 (vertical axis) is 200.0 mm



Note. Input the same positioning commands (point table data) to the driven shaft (axis 2) as those for the main shaft (axis 1).

Fig. 12.1.6 Driving example

Set the following items as follows to move up and down the axis 2 in synchronization with the to-and-fro control using absolute value commands with point table No. 1 and 2 of the axis 1.

Setting example of axis 1

Item	Setting	Setting value
Operation mode selection ([Pr. PA01])	Select "Point table method".	"1006"
Positioning command method selection ([Pr. PT01])	Select "Absolute value command method".	"_ _ _ 0"
Command unit ([Pr. PT01])	Set "mm" as the unit of position data.	"_ 0 _ _"
Main shaft input axis selection ([Cam control data No. 30])	Select "Servo input axis".	1
Point table No. 1	Set the target position (outward path in the to-and-fro control).	600.000
	Set "Absolute value command method" for the auxiliary function.	"0", "1", "8", or "9"
Point table No. 2	Set the target position (return path in the to-and-fro control).	0.000
	Set "Absolute value command method" for the auxiliary function.	"0", "1", "8", or "9"

12. APPLICATION OF FUNCTIONS

Setting example of axis 2

Item	Setting	Setting value
Operation mode selection ([Pr. PA01])	Select "Point table method".	"1006"
Simple cam function setting ([Pr. PT35])	Enable the simple cam function.	"_ 1 _ _"
Device setting	Assign CAMC (Cam control command input), CAMS (Output in cam control), and CI0 to CI3 (Cam No. selection 0 to 3) with I/O setting parameters ([Pr. PD_ _]).	Refer to section 7.2.4.
Command unit ([Pr. PT01])	Set "mm" as the unit of position data.	"_ 0 _ _"
Cam axis one cycle length ([Cam control data No. 30])	Set the travel distance of the axis 1 (horizontal axis).	600.000
Cam stroke amount ([Cam control data No. 51])	Set the travel distance of the axis 2 (vertical axis).	200.000
Main shaft input axis selection ([Cam control data No. 30])	Select "Servo input axis".	1
Point table No. 1	Set the same target position as that of the point table No. 1 of the axis 1. Set the same servo motor speed and acceleration/deceleration time constants for the point table No. 1 of the axis 1.	600.000
Point table No. 2	Set the same target position as that of the point table No. 2 of the axis 1. Set the same servo motor speed and acceleration/deceleration time constants for the point table No. 2 of the axis 1.	0.000
Cam data	Create a cam pattern according to the axis 1 position. (Refer to Fig. 12.1.6.)	

(b) Operation

The following table shows an example of the procedure before operation.

Step	Setting and operation
1. Data setting	Refer to the setting example on the previous page and set the data.
2. Initial position adjustment	Adjust the synchronous positions of the axis 1 and 2. In this example, when the position of the axis 1 (command position) is "0", adjust the synchronous position so that the position of the axis 2 (feed current value) becomes "0".
3. Point table selection	Select the point table No. 1 for both axis 1 and 2.
4. Selecting cam data	Select the cam data to be executed with CI0 to CI3 (Cam No. selection 0 to 3) of the axis 2. The user can use [Cam control data No. 49 - Cam No.] to select the cam data.
5. Servo-on	Switch on SON (Servo-on) for both axis 1 and 2.
6. Switching cam control	Switch on CAMC (Cam control command) of the axis 2 to switch the control to the cam control.
7. Starting the simultaneous start function	Check CAMS (During cam control) of the axis 2 is on and start the operations of the axis 1 and 2 simultaneously. The axis 2 is driven in synchronization with the axis 1.

12. APPLICATION OF FUNCTIONS

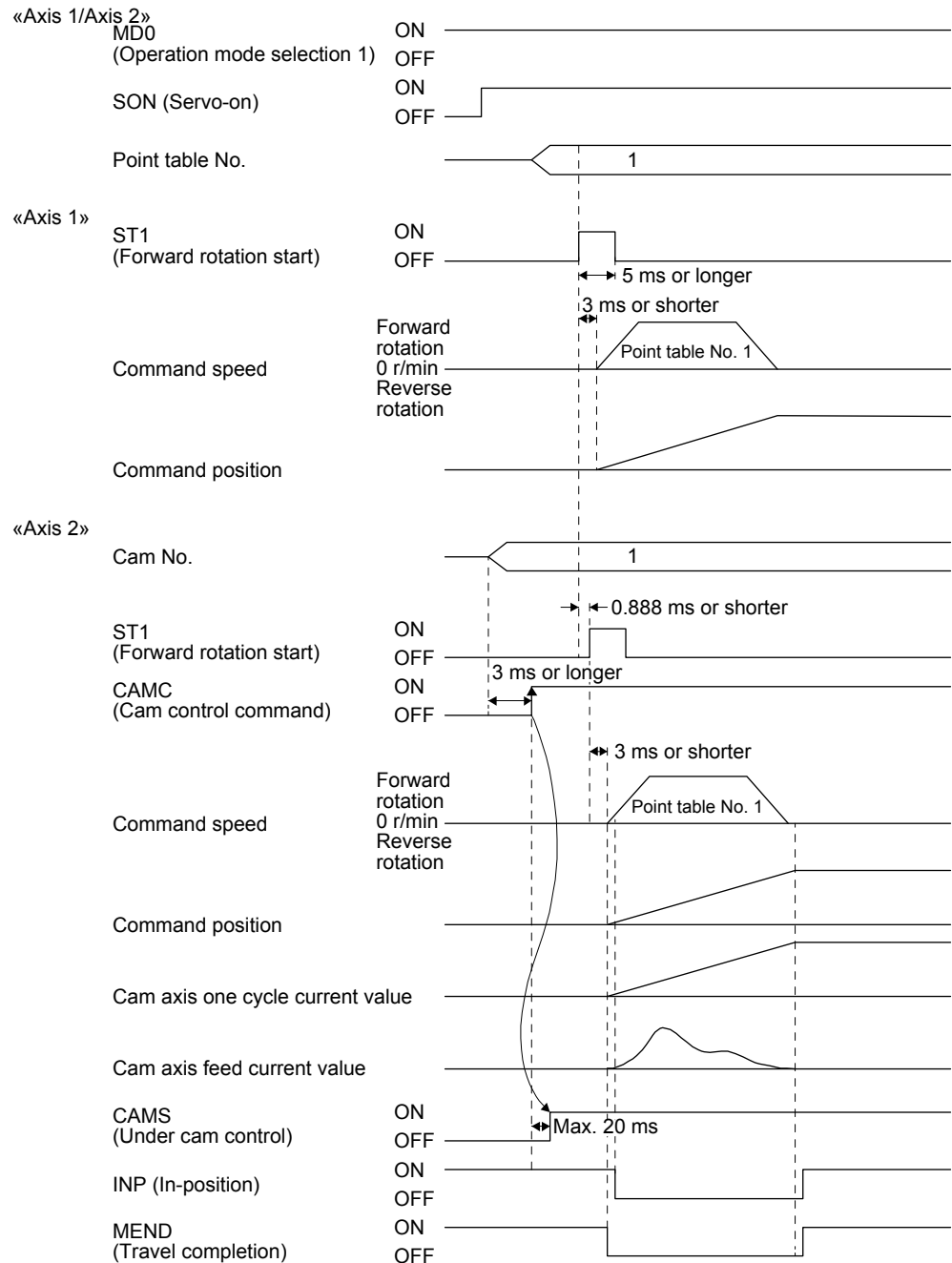

Fig. 12.1.7 Timing chart

Input start commands simultaneously with the DI signal or serial communication from controllers such as programmable controllers. The start delay time of the main shaft and driven shaft is 888 μ s at a maximum because it depends on the fetch cycle of the start signal. The detection of external input signals is delayed by the time set in the input filter setting of [Pr. PD29].

Even though CAMC turns on, the command is not reflected after ST1 turns on (during point table operation or JOG operation). The command is not also reflected even though CAMC turns on in the servo-off state.

CAMC is determined at the on edge, not on level. Even though CAMC turns off or on before CAMS turns on, the command is not reflected.

12. APPLICATION OF FUNCTIONS

12.1.10 Cam No. setting method

POINT
<p>● When the cam No. is set to a value other than "0" to "8", [AL. F6.5 Cam No. external error] will occur. If the cam data of a specified cam No. does not exist, [AL. F6.3 Cam unregistered error] occurs. At this time, the cam control is not executed and the servo motor does not start. Turning off the cam control command clears [AL. F6.3] and [AL. F6.5].</p>

You can use external input signals or serial communication commands to set and change the cam No. in the same way as the method specified with [Cam control data No. 49] or the method for selecting a point table No.

Use CI0 (Cam No. selection 0) to CI3 (Cam No. selection 3) as external input signals.

Use commands [92] [61] (Writing DI function bit map) as communication commands.

Modbus-RTU communication uses Cam number setting (2D80h). Refer to section 5.8.12 of "MR-J4- _A_ -RJ Servo Amplifier Instruction Manual (Modbus-RTU communication)" for how to set a cam No.

The following table lists the priority of each parameter, external input signal, and communication command.

[Pr. PT35] setting	[Cam control data No. 49] setting	External input signal	Communication command	Setting
_ 0 _ _ (Simple cam function disabling setting)	×	×	×	The cam function will be disabled with the setting of [Pr. PT35].
_ 1 _ _ (Simple cam function enable setting)	"0" (initial value)	○	○	The cam No. is set with the setting of external input signals or communication commands.
	Other than "0"	×	×	The cam No. is set with the setting of [Cam control data No. 49]. The cam No. setting with external input signals or communication commands is disabled.

Note 1. ○: Enable, ×: Disable

2. The on/off state of CI0 to CI3 is determined with OR of external input signals and communication command settings.
- On: Either of an external input signal or a communication command turns on.
 - Off: Both of the external input signal and communication command turn off.

12. APPLICATION OF FUNCTIONS

12.1.11 Stop operation of cam control

If one of the following stop causes occurs on the output axis during cam control, the cam control stops after the output axis is stopped. (CAMS turns off.)

To restart the cam control, adjust the synchronous position of the output axis.

Stop cause	Command stop processing	Remark
Software stroke limit detection	Instantaneous stop	Refer to (1).
Stroke limit detection	Instantaneous stop	Refer to (1).
Stop due to forced stop 1 or 2, or alarm occurrence	Instantaneous stop or deceleration to a stop	Stop due to base circuit shut-off Refer to (1). Stop by the forced stop deceleration function Refer to (2).
Cam control command (CAMC) OFF	Instantaneous stop	Refer to (1).
Servo-off	Instantaneous stop	Coasting state

(1) Instantaneous stop

The operation stops without deceleration. The servo amplifier immediately stops the command.

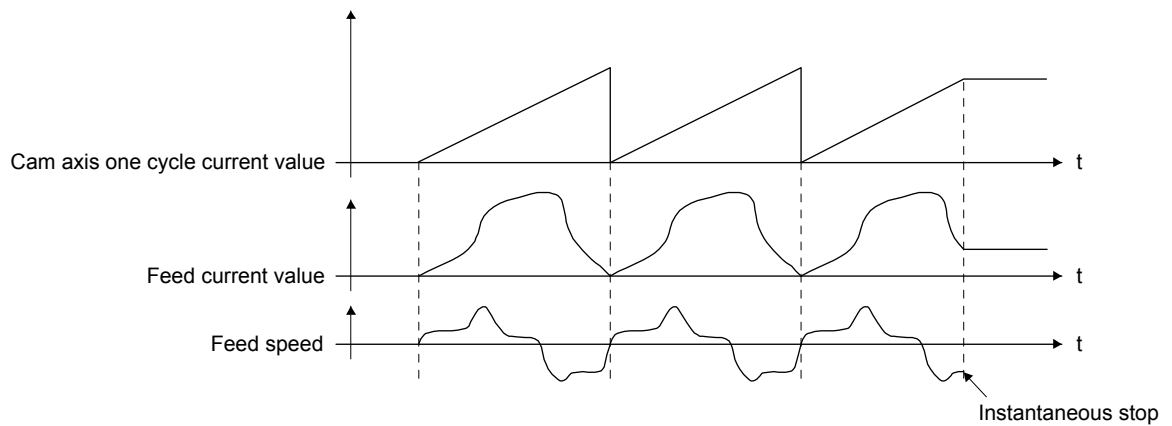

12. APPLICATION OF FUNCTIONS

(2) Deceleration stop

The output axis decelerates to stop according to [Pr. PC51 Forced stop deceleration time constant]. After a deceleration stop starts, the cam axis one cycle current value and feed current value are not updated. The path of the feed current value is drawn, and the stop is made regardless of the cam control.

Decelerate the input axis to stop when decelerating the output axis to stop in synchronization with the input axis.

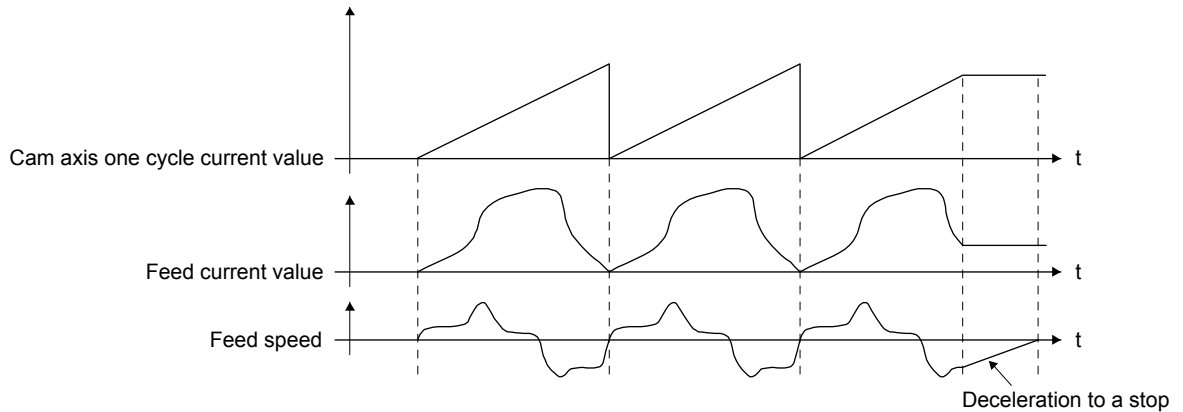

When using a positioning command (internal command) for the input axis, inputting a temporary stop or switching the operation mode decelerates the input axis to stop. Since the output axis stops in synchronization with the input axis, the synchronous relationship is kept and the cam control does not stop.

When the control mode is switched to the home position return mode, the cam control will stop.

12. APPLICATION OF FUNCTIONS

12.1.12 Restart operation of cam control

When the cam control is stopped during operation, a gap is generated in the synchronization between the main shaft and the driven shaft. To solve the gap, return the main shaft and the driven shaft to the synchronization starting point and then start the synchronous operation.

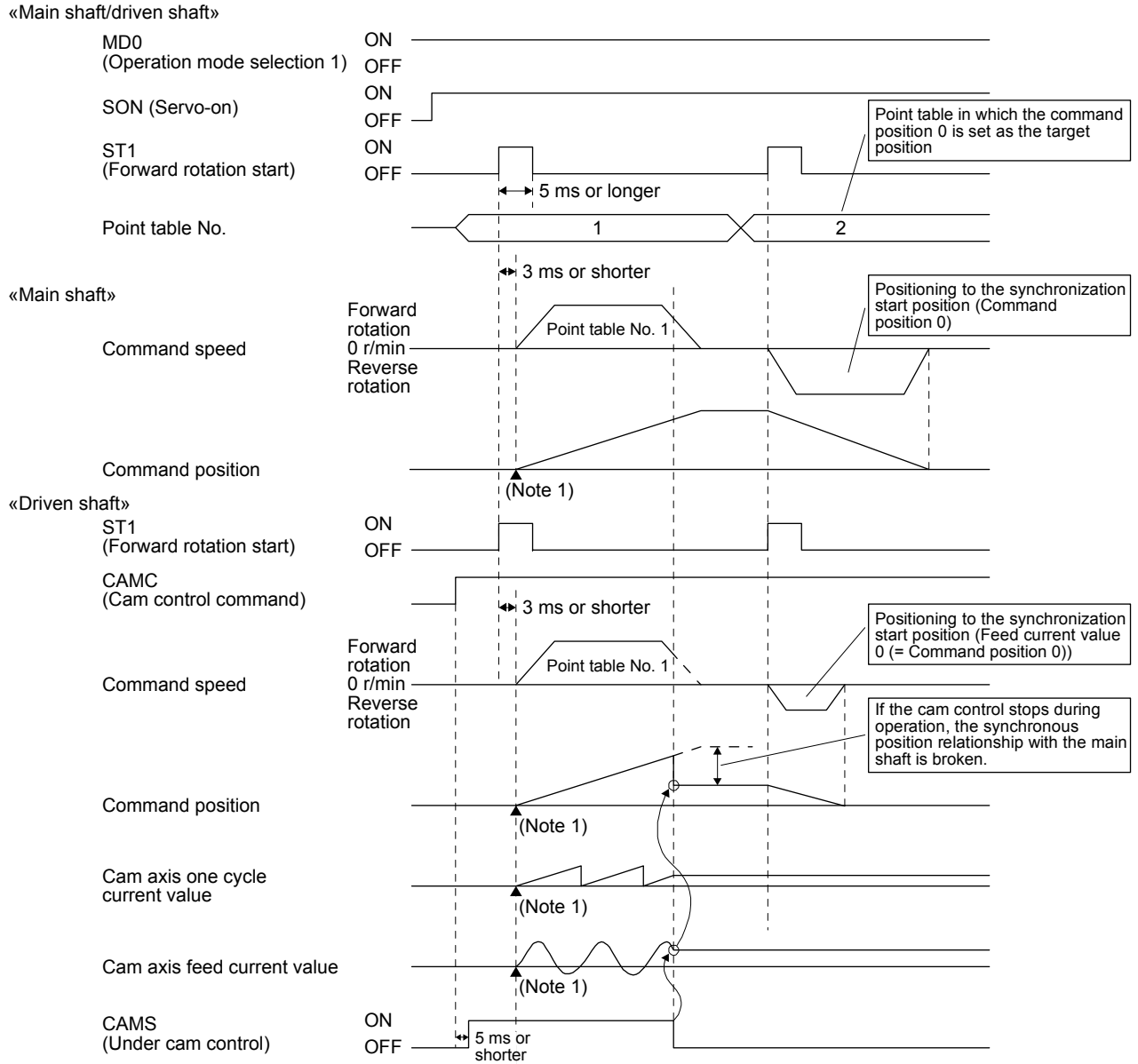

The above shows an example for when the synchronization starting point is the point where both command position and feed current value are "0".

12. APPLICATION OF FUNCTIONS

12.1.13 Cam axis position at cam control switching

The cam axis position is determined by the positional relationship of three values of "Cam axis one cycle current value", "Cam axis standard position" and "Cam axis feed current value". When the control has been switched to the cam control (CAMC (Cam control command) is on), defining the positions of two of these values restores the position of the remaining one value.

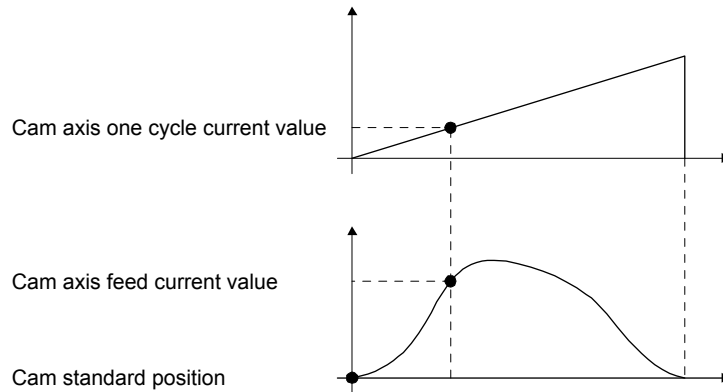

The following table lists the parameters required to be set for the cam axis position restoration. Refer to section 12.1.7 (3) for the settings.

Cam axis position restoration target ([Cam control data No. 2])	Cam standard position setting method ([Cam control data No. 3])	Cam standard position (initial setting value) ([Cam control data No. 6])	Cam axis one cycle current value setting method ([Cam control data No. 4])	Cam axis one cycle current value (initial setting value) ([Cam control data No. 7])	Restoration processing details
0: Cam axis one cycle current value	○	○ (Note)	/	○ (Used as the search starting point of cam pattern.)	"Cam axis one cycle current value" is restored based on "Cam standard position" and "Cam axis feed current value".
1: Cam standard position	/	/	○	○ (Note)	"Cam standard position" is restored based on "Cam axis one cycle current value" and "Cam axis feed current value".
2: Cam axis feed current value	○	○ (Note)	○	○ (Note)	"Cam axis feed current value" is restored based on "Cam axis one cycle current value" and "Cam standard position".

○: Required

Note. Set this parameter when [Cam control data No. 3] is set to "1".

12. APPLICATION OF FUNCTIONS

(1) Cam axis one cycle current value restoration

POINT
<ul style="list-style-type: none"> ● For the cam pattern of to-and-fro control, if no corresponding cam axis one cycle current value is found, [AL. F6.1 Cam axis one cycle current value restoration failed] will occur and cam control cannot be executed. ● For the cam pattern of feed control, if no corresponding cam axis one cycle current value is found, the cam standard position will automatically change and the value will be searched again. ● If the cam resolution of the cam used is large, search processing at cam control switching may take a long time.

When CAMC (Cam control command) turns on, "Cam axis one cycle current value" is restored based on "Cam standard position" and "Cam axis feed current value" and the control is switched to the cam control. Set the "cam standard position" used for the restoration with cam control data. The feed current value at cam control switching is used as "Cam axis feed current value".

The cam axis one cycle current value is restored by searching for a corresponding value from the beginning to the end of the cam pattern.

Set the starting point for searching the cam pattern with "[Cam control data No. 7 Cam axis one cycle current value (initial setting value)]". (It is also possible to search from the return path in the cam pattern of to-and-fro control.)

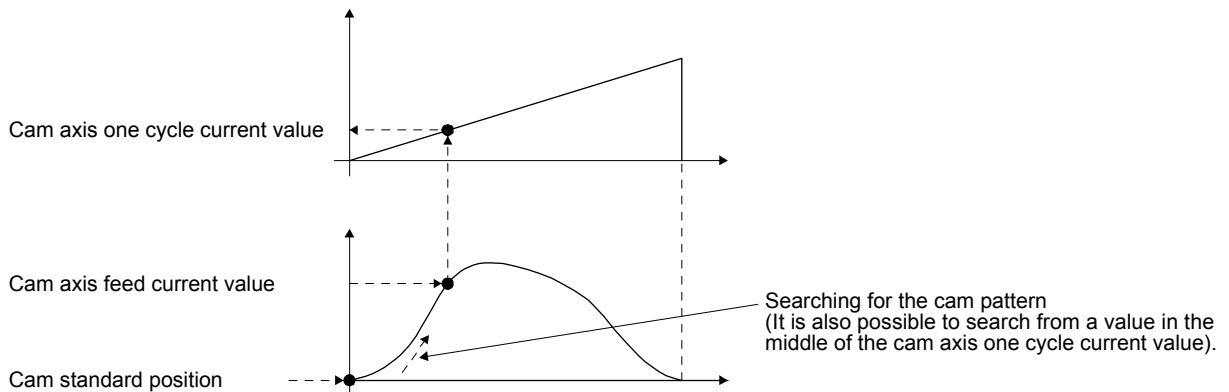

12. APPLICATION OF FUNCTIONS

(a) Cam pattern of to-and-fro control

1) Searching from "Cam axis one cycle current value = 0" (Cam data start position = 0)

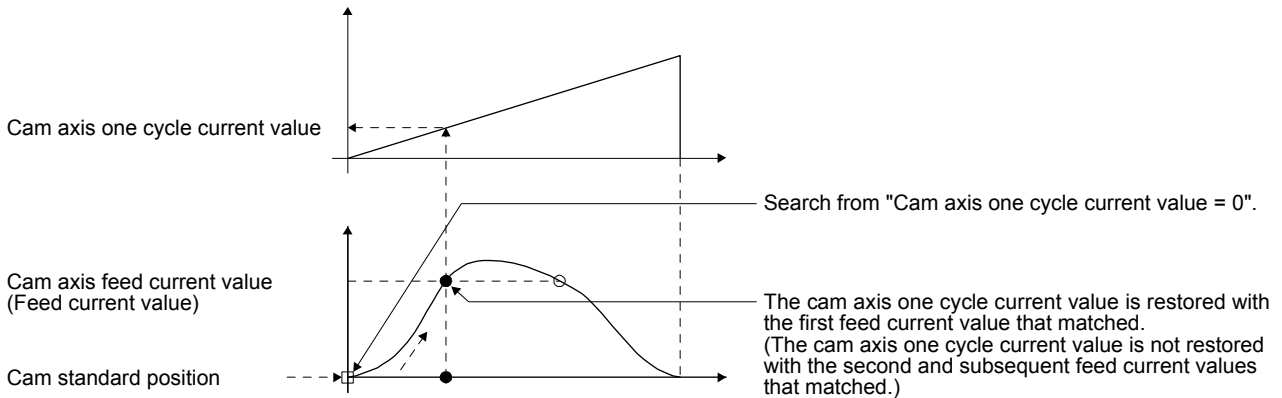

2) Searching from a value in the middle of the cam axis one cycle current value (Cam data start position = 0)

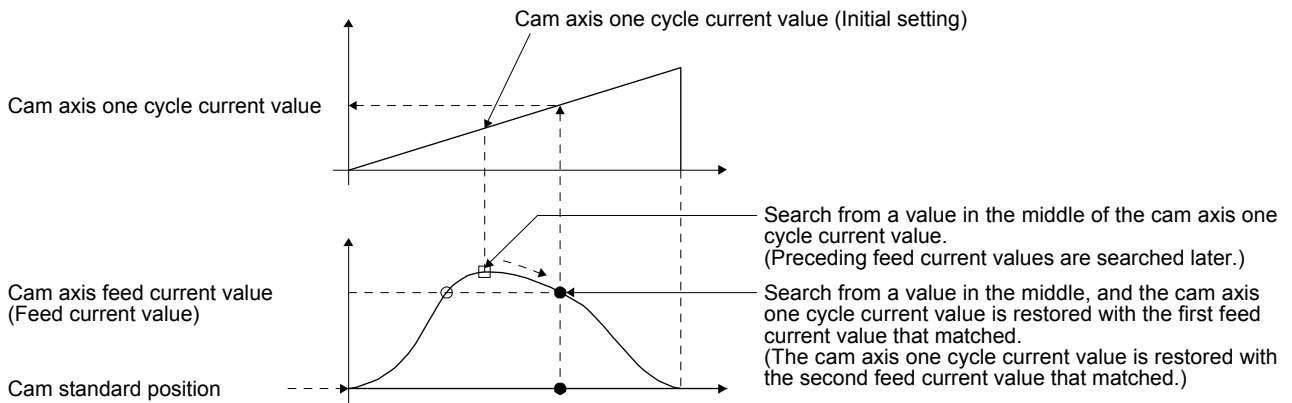

3) Searching from a value in the middle of the cam axis one cycle current value (Cam data start position $\neq 0$)

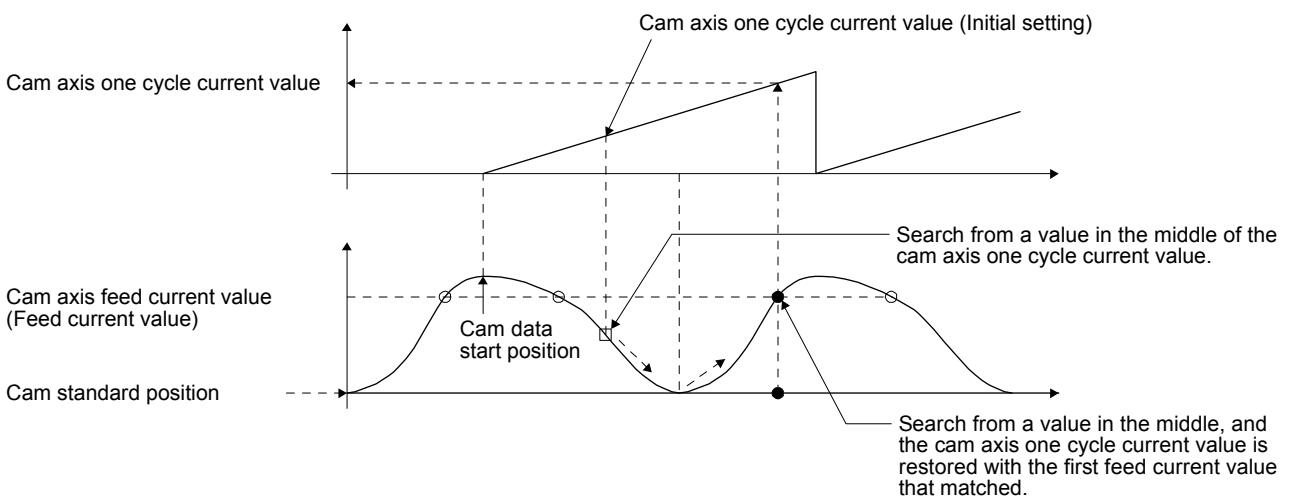

12. APPLICATION OF FUNCTIONS

4) Searching fails

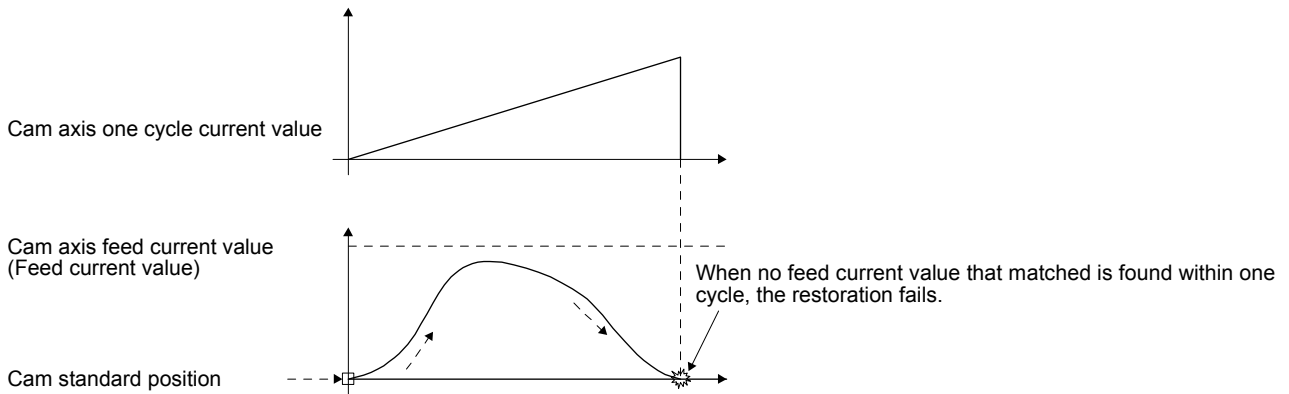

(b) Cam pattern of feed control

1) Searching from "Cam axis one cycle current value = 0" (Cam data start position = 0)

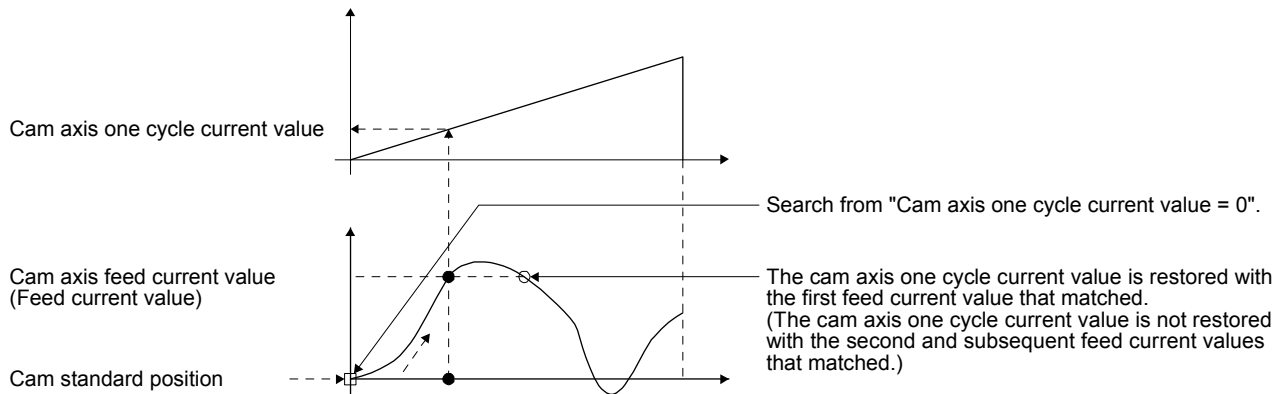

2) Searching from a value in the middle of the cam axis one cycle current value (Cam data start position = 0)

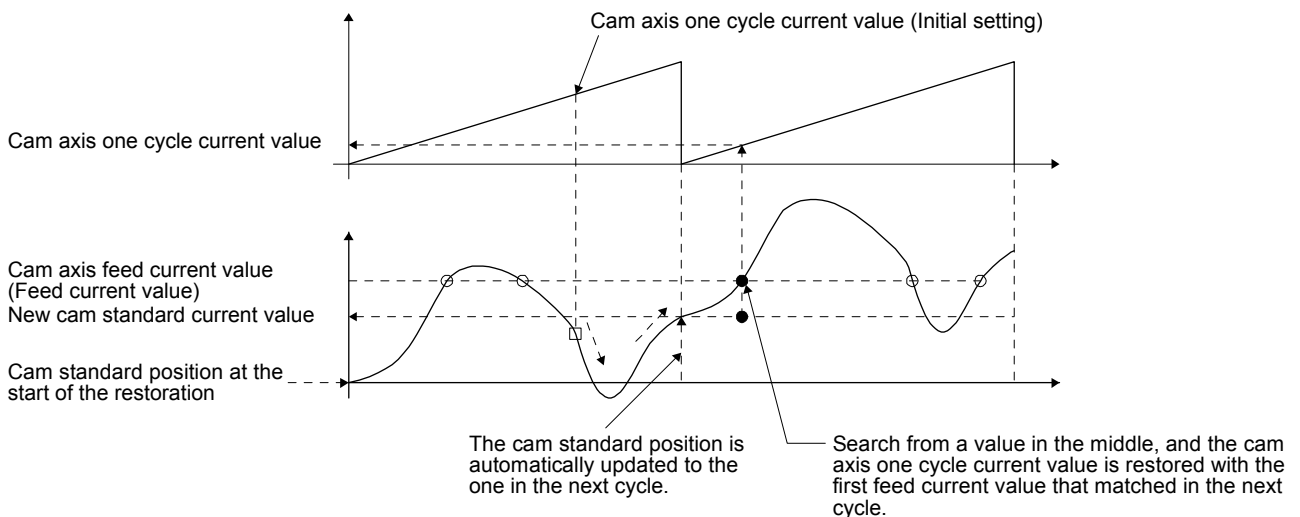

12. APPLICATION OF FUNCTIONS

- 3) Searching from a value in the middle of the cam axis one cycle current value (Cam data start position $\neq 0$)

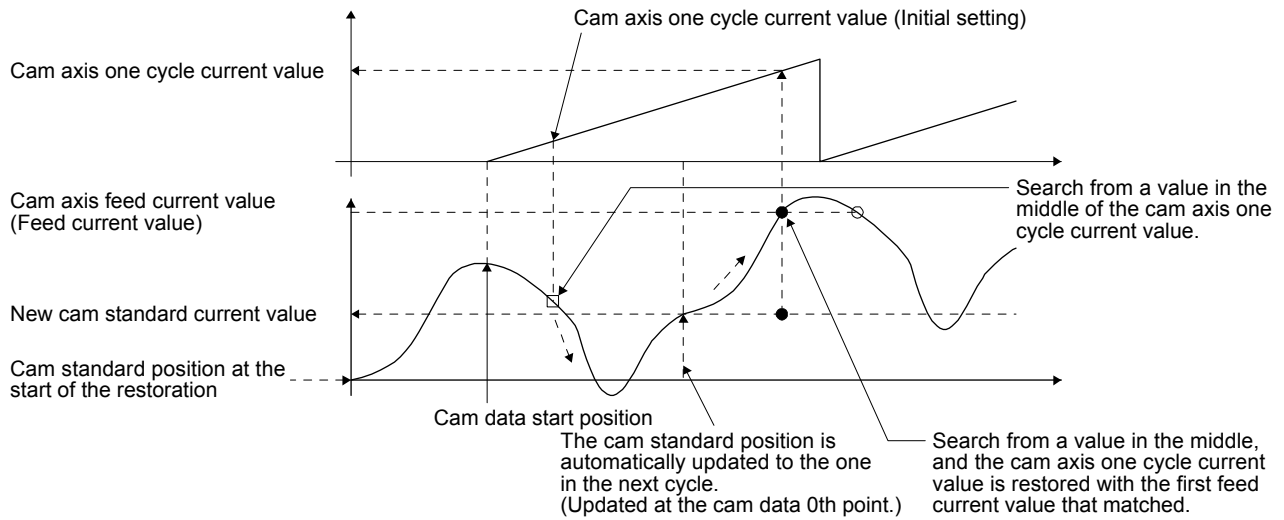

- 4) The first searching has failed and the second searching starts

POINT
<p>● If the first searching has failed, the second searching may not be processed in the next cycle for a cam pattern with a feed stroke smaller than 100%. By setting or positioning a cam standard position in advance, an intended cam axis one cycle current value can be found in the first searching.</p>

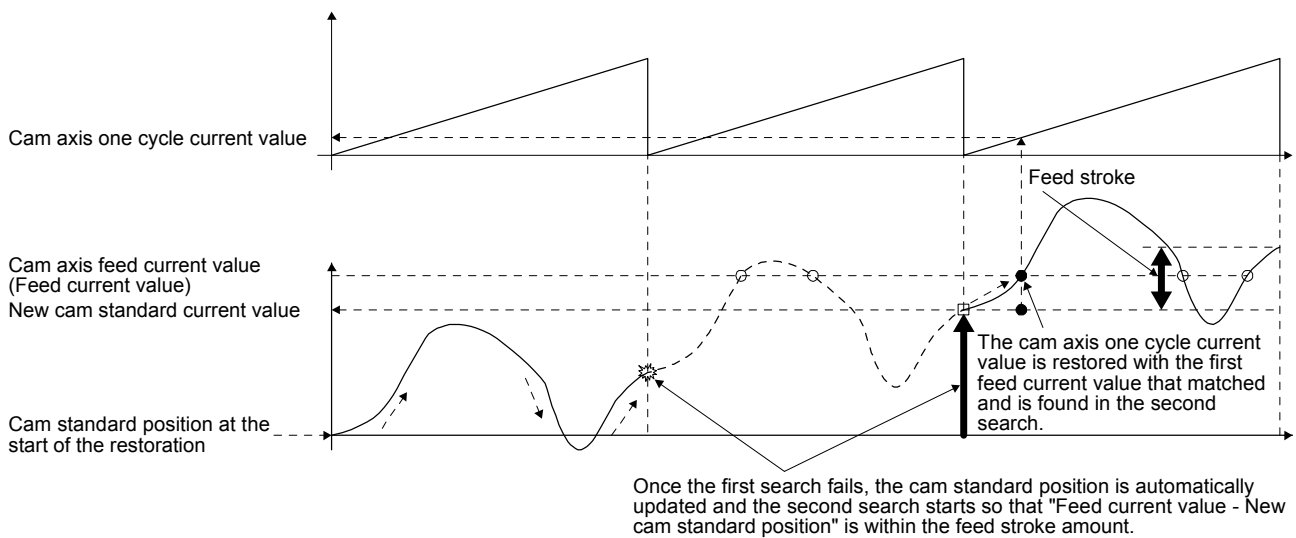

12. APPLICATION OF FUNCTIONS

(2) Cam standard position restoration

If the cam axis position restoration target is set to "Cam standard position restoration" and CAMC (Cam control command) turns on, the "cam standard position" will be restored based on "Cam axis one cycle current value" and "Cam axis feed current value" and the control is switched to the cam control.

Set the "cam axis one cycle current value" used for restoration with cam control data. The feed current value of when CAMC (Cam control command) is on is used as the "cam axis feed current value".

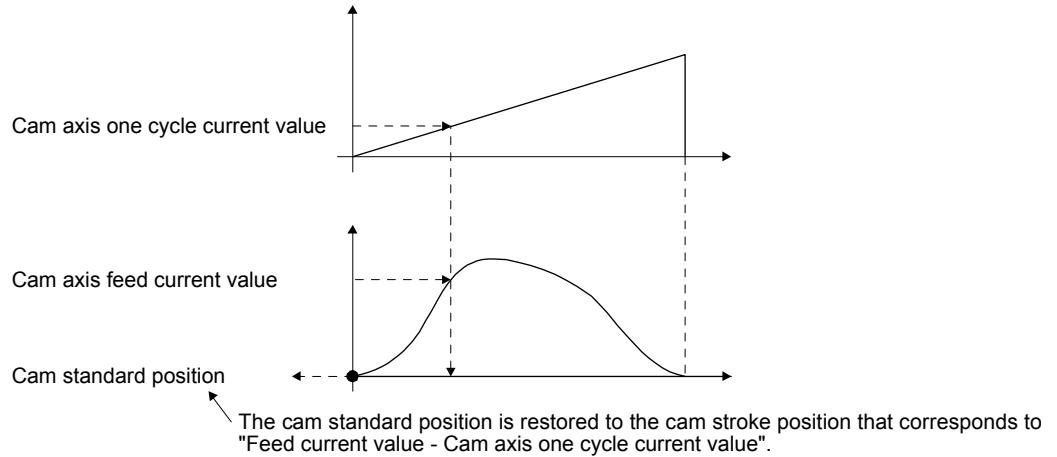

The following shows an example for restoring the cam standard position to start an operation from a point where both the feed current value and the cam axis one cycle current value are 0" in the cam whose cam data start position is not "0".

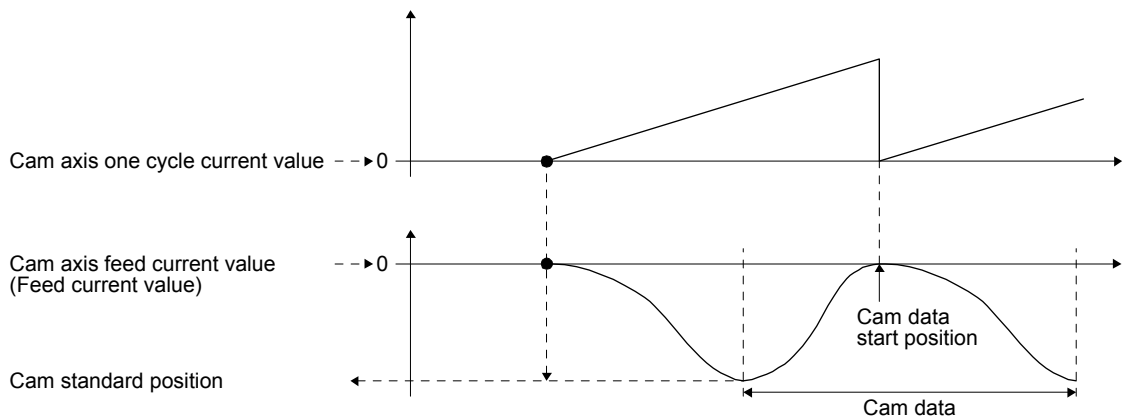

12. APPLICATION OF FUNCTIONS

(3) Cam axis feed current value restoration

POINT
<ul style="list-style-type: none">● When the restored cam axis feed current value differs from the feed current value at cam control switching, the cam axis feed current value moves to the value restored just after cam control switching.● If the difference between the restored cam axis feed current value and the feed current value is larger than the value set in [Pr. PA10 In-position range], [AL. F6.2 Cam axis feed current value restoration failed] will occur and the control cannot be switched to the cam control. Note that, if increasing the value of the in-position range may lead to a rapid cam switching.

If the cam axis position restoration target is set to "Cam axis feed current value restoration" and CAMC (Cam control command) turns on, "Cam axis feed current value" is restored based on "Cam axis one cycle current value" and "Cam standard position" and the control is switched to the cam control. Set the "cam axis one cycle current value" and "cam standard position" used for the restoration with cam control data.

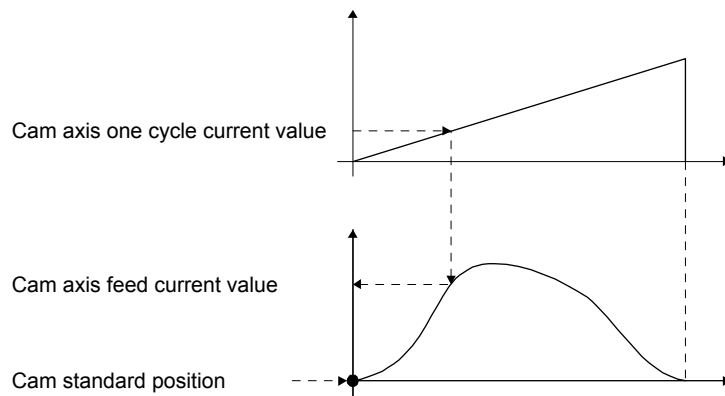

12. APPLICATION OF FUNCTIONS

12.1.14 Clutch

POINT
<ul style="list-style-type: none">● Use C_CLTC (Clutch command (bit 11 of 2D02h)) to input a clutch command via the Modbus-RTU communication. Use S_CLTS (Clutch on/off status (bit 11 of 2D12h)) to read the output status of the clutch on/off status.● Use S_CLTSM (Clutch smoothing status (bit 12 of 2D12h)) to read the output status of the clutch smoothing status via the Modbus-RTU communication.● C_CLTC, S_CLTS, and S_CLTSM are available with servo amplifiers with software version C1 or later. For details, refer to "MR-J4-_A_-RJ Servo Amplifier Instruction Manual (Modbus-RTU communication)".

The clutch is used to transmit/disengage command pulses from the main shaft input side to the output axis module through turning the clutch ON/OFF, controlling start/stop of the servo motor operation. Set whether or not to use the clutch control with [Cam control data No. 36 - Main shaft clutch control setting]. Although the clutch ON/OFF can be changed during cam control, the setting of [Cam control data No. 36] cannot be changed from "1 (Clutch command ON/OFF)" to "0 (No clutch)" during cam control. When the clutch ON condition and the clutch OFF condition are simultaneously established within the DI scan cycle, both clutch ON processing and clutch OFF processing are executed within the DI scan cycle. Therefore, the clutch status changes from OFF to ON and OFF again when the conditions are established in the clutch OFF status, and the status changes from ON to OFF and ON again when the conditions are established in the clutch ON status.

12. APPLICATION OF FUNCTIONS

(1) ON control mode

(a) "No clutch"

When [Cam control data No. 36 - Main shaft clutch control setting] is set to "0 (No clutch)", other clutch parameters are not used due to direct coupled operation.

(b) Clutch command ON/OFF

Turning on/off CLTC (Clutch command) turns on/off the clutch.

(Settings in the OFF control mode are not used in the clutch command ON/OFF mode.)

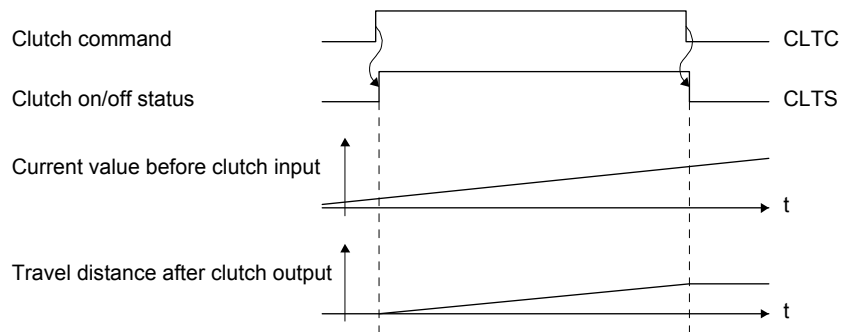

(2) Clutch smoothing method

Smoothing is processed with the time constant set in [Cam control data No. 43 Main shaft clutch smoothing time constant] at clutch ON/OFF. After clutch ON smoothing is completed, smoothing is processed with the set time constant when the speed of the input values changes.

The travel distance from turning on to off of the clutch does not change with smoothing.

Travel distance after clutch smoothing = Travel distance before clutch smoothing

Time constant method exponential curve smoothing

Set [Cam control data No. 42 - Main shaft clutch smoothing system] to "1 (Time constant method (index))".

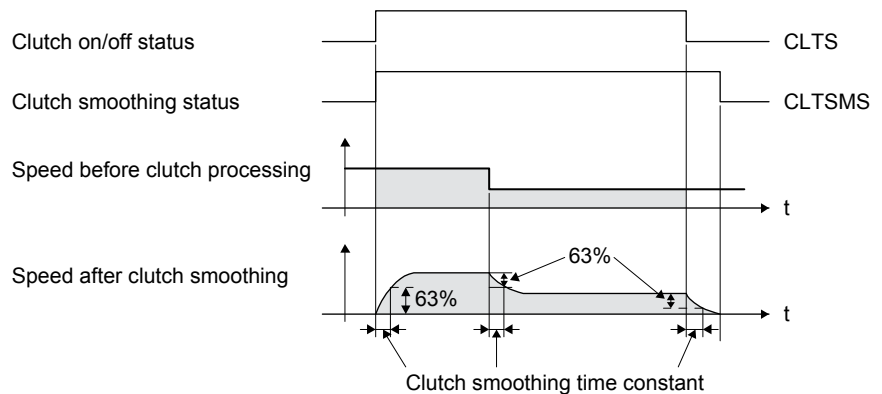

12. APPLICATION OF FUNCTIONS

12.1.15 Cam position compensation target position

Perform compensation to match the cam axis one cycle current value with the cam position compensation target position ([Cam control parameter No. 60]) by inputting a cam position compensation request.

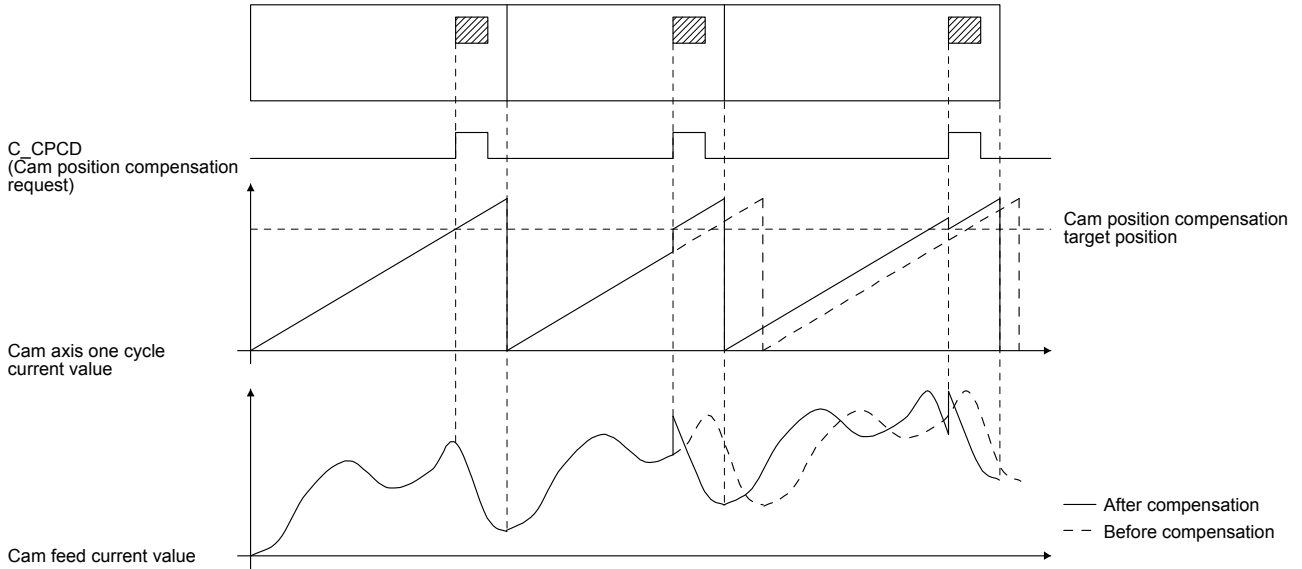

12. APPLICATION OF FUNCTIONS

12.1.16 Cam position compensation time constant

POINT
<ul style="list-style-type: none"> ● Use C_CPCD (Cam position compensation request (bit 13 of 2D02h)) to input a cam position compensation request via the Modbus-RTU communication. Use S_CPCC (Cam position compensation execution completed (bit 13 of 2D12h)) to read the output status of Cam position compensation execution completed. ● C_CPCD and S_CPCC are available with servo amplifiers with software version C1 or later. For details, refer to "MR-J4-_A_-RJ Servo Amplifier Instruction Manual (Modbus-RTU communication)".

The compensation amount calculated when cam position compensation is requested is divided into the time set in [Cam control data No. 61 Cam position compensation time constant] and used for compensation.

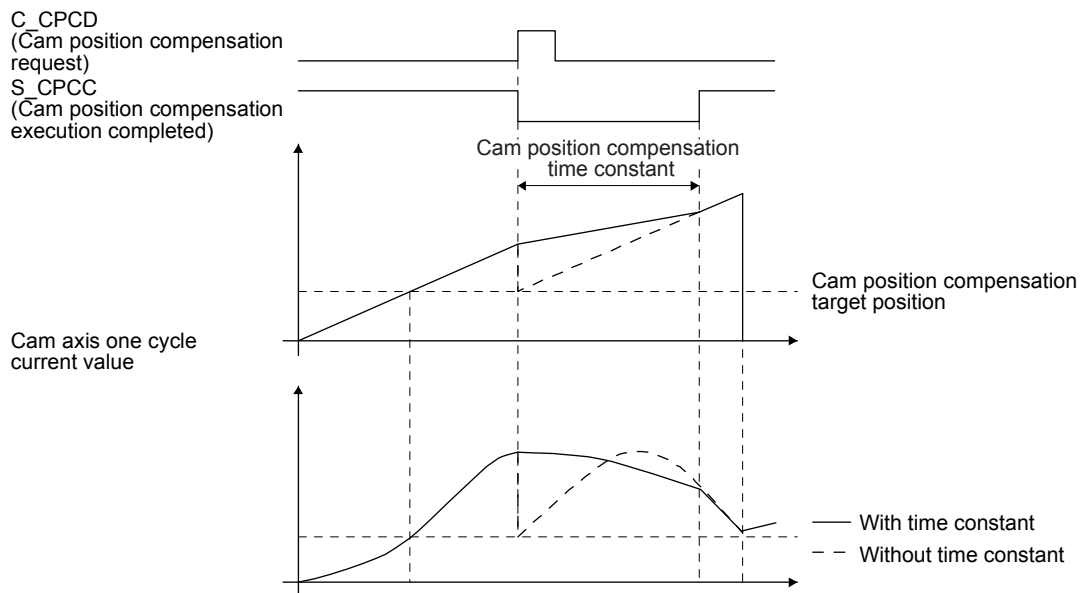

12. APPLICATION OF FUNCTIONS

12.2 Mark detection

12.2.1 Current position latch function

POINT
<ul style="list-style-type: none"> ● The current position latch function can be used with the point table method and the program method. However, the current position latch function is disabled in the following condition. <ul style="list-style-type: none"> ▪ Home position return ▪ Manual operation (excluding home position return) ● The latched actual current position data can be read with communication commands. ● For the servo amplifiers with software version B6 or earlier, the latched position data is not compatible with the current position of the state monitor when the roll feed display function is enabled. Disable the roll feed display function to compare the current data of the state monitor and the latched position data. ● For the servo amplifiers with software version B7 or later, the read latched position data is equal to the travel distance as the starting point is set to "0" when the roll reed display function is enabled. The output value is the same as the current position of the state monitor.

When the mark detection signal turns on, the current position is latched. The latched data can be read with communication commands.

- (1) Communication command
Reads mark detection data.

Command	Data No.	Description	Control mode			Frame length
			CP/BCD	CL	PS	
[1] [A]	[0] [0]	MSD (Mark detection) rising latch data (data part)	○	○	/	8
	[0] [1]	MSD (Mark detection) falling latch data (data part)	○	○	/	
	[0] [2]	MSD (Mark detection) rising latch data (data part + additional information)	○	○	/	12
	[0] [3]	MSD (Mark detection) falling latch data (data part + additional information)	○	○	/	

12. APPLICATION OF FUNCTIONS

(2) Reading data

(a) Rising latch data or falling latch data (data part)

Reads MSD (Mark detection) rising latch data or MSD (Mark detection) falling latch data.

1) Transmission

Transmit command [1] [A] and latch data No. to be read [0] [0] or [0] [1]. Refer to section 10.1.1.

2) Return

The slave station returns the requested latch data.



Data will be received in hexadecimal per set command.
Hexadecimal should be changed to decimal.

Example

Data "000186A0" will be 100.000 mm in the command-side unit.

A decimal point position depends on setting contents of [Pr. PT01] and [Pr. PT03].

(b) Rising latch data or falling latch data (data part + additional information)

Reads MSD (Mark detection) rising latch data or MSD (Mark detection) falling latch data.

1) Transmission

Transmit command [1] [A] and latch data No. to be read [0] [2] or [0] [3]. Refer to section 10.1.1.

2) Return

The slave station returns the requested latch data.

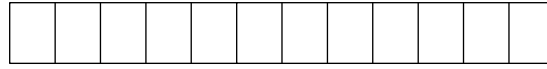

Data will be received in hexadecimal per set command.
Hexadecimal should be changed to decimal.

Example

Data "0040000186A0" will be 100.000 mm in the command-side unit.

Decide the decimal point position with [Pr. PT01] and [Pr. PT03].

Display type

0: Data must be converted into decimal.

1: Data is used unchanged in hexadecimal.

Decimal point position

0: No decimal point

1: First least significant digit (not used normally)

2: Second least significant digit

3: Third least significant digit

4: Forth least significant digit

5: Fifth least significant digit

12. APPLICATION OF FUNCTIONS

(3) Parameter

Set the parameters as follows:

Item	Parameter to be used	Setting
Mark detection function selection	[Pr. PT26]	Set the mark detection function selection as follows: 0 _ _ _ : Current position latch function
Mark detection range + (lower three digits)	[Pr. PC66]	Set the upper limit of the latch data in the current position latch function. When the roll feed display is enabled, set this value with the travel distance from the starting position. Set the same sign for [Pr. PC66] and [Pr. PC67]. A different sign will be recognized as minus sign data. When changing the direction to address decreasing, change it from the - side of the mark detection ([Pr. PC68] and [Pr. PC69]). An incorrect order of the setting will trigger [AL. 37]. Therefore, cycling power may be required after [Pr. PC66] to [Pr. PC69] are all set. This parameter setting is available with servo amplifiers with software version B7 or later.
Mark detection range + (upper three digits)	[Pr. PC67]	
Mark detection range - (lower three digits)	[Pr. PC68]	Set the lower limit of the latch data in the current position latch function. When the roll feed display is enabled, set this value with the travel distance from the starting position. Set the same sign for [Pr. PC68] and [Pr. PC69]. A different sign will be recognized as minus sign data. When changing the direction to address increasing, change it from the + side of the mark detection ([Pr. PC66] and [Pr. PC67]). An incorrect order of the setting will trigger [AL. 37]. Therefore, cycling power may be required after [Pr. PC66] to [Pr. PC69] are all set. This parameter setting is available with servo amplifiers with software version B7 or later.
Mark detection range - (upper three digits)	[Pr. PC69]	

12. APPLICATION OF FUNCTIONS

(4) Latch data range setting

The current position is latched only within the range set in [Pr. PC66] to [Pr. PC69].

When a same value is set for the upper and lower limits, the current value will be latched for a whole range.

(a) mm, inch, and pulse unit

The current position latch function is enabled when Upper limit value > Lower limit value. The valid range is the same for the absolute value command ([Pr. PT01]: ___ 0) and the incremental value command ([Pr. PT01]: ___ 1).

[AL. 37 occurs] when Upper limit value < Lower limit value.

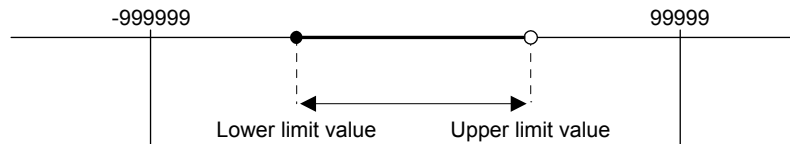

1) When the roll feed display is disabled ([Pr. PT26]: __ 0 _)

Set the valid range with the distance from the home position.

When the starting position is at 100000, [Pr. PC66] and [Pr. PC67] are set to 500000, and [Pr. PC68] and [Pr. PC69] are set to 300000, the valid range is between the actual current position of 300000 and 500000 as set in the parameters.

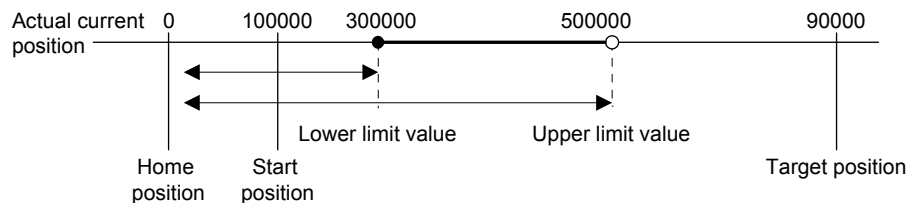

2) When the roll feed display is enabled ([Pr. PT26]: __ 1 _)

When the roll feed display is enabled, the valid range is calculated as the starting position is "0".

Set the valid range with the travel distance from the starting position.

When the starting position is at 100000, [Pr. PC66] and [Pr. PC67] are set to 500000, and [Pr. PC68] and [Pr. PC69] are set to 300000, the valid range is between the feed current position of 300000 and 500000 from the start position (between the actual current position of 400000 and 600000).

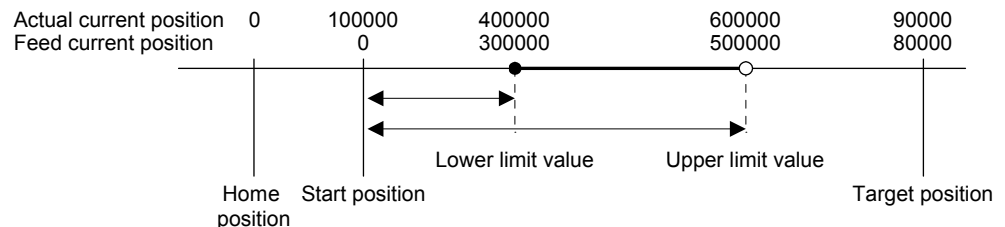

12. APPLICATION OF FUNCTIONS

(b) Degree unit

When the unit is set to [degree], the setting range of the current position latch is from 0 degree (upper limit) to 359.999 degrees (lower limit).

When you set a value other than 0 degree to 359.999 degrees in the current position latch +/- [Pr. PC66] to [Pr. PC69], the set value is converted as follows.

Current position latch range	After conversion
360.000 degrees to 999.999 degrees	(Setting value) % 360
-0.001 degrees to -359.999 degrees	360 + (setting value)
-360.000 degrees to -999.999 degrees	(setting value) % 360 + 360

The valid range of the current position latch varies depending on the setting of the upper and lower limits.

The valid range remains unchanged even if the rotation direction is reversed.

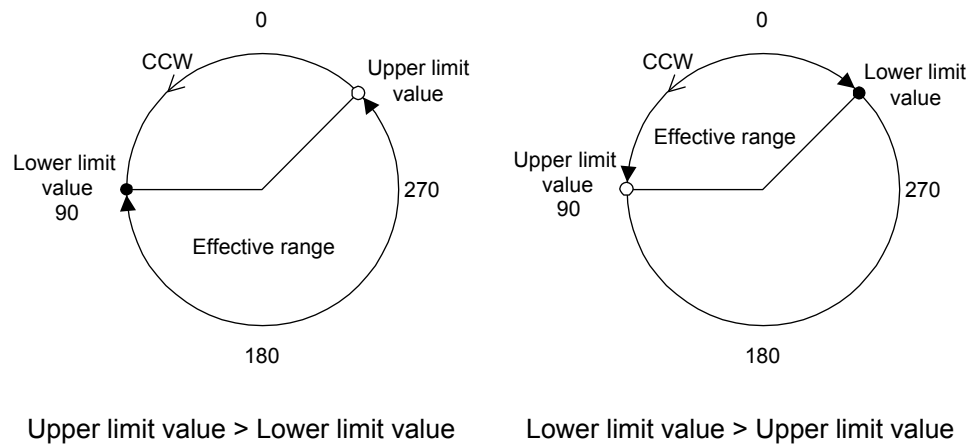

To enable the current position latch function of section A in the figure, set the parameters as follows:

Current position latch range -: 315.000 degrees ([Pr. PC68]: 0, [Pr. PC69]: 315)

Current position latch range +: 90.000 degrees ([Pr. PC66]: 0, [Pr. PC67]: 90)

To enable the current position latch function of section B in the figure, set the parameter as follows:

Current position latch range -: 90.000 degrees ([Pr. PC68]: 0, [Pr. PC69]: 90)

Current position latch range +: 315.000 degrees ([Pr. PC66]: 0, [Pr. PC67]: 315)

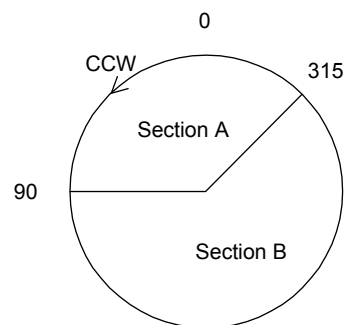

12. APPLICATION OF FUNCTIONS

(5) Timing chart

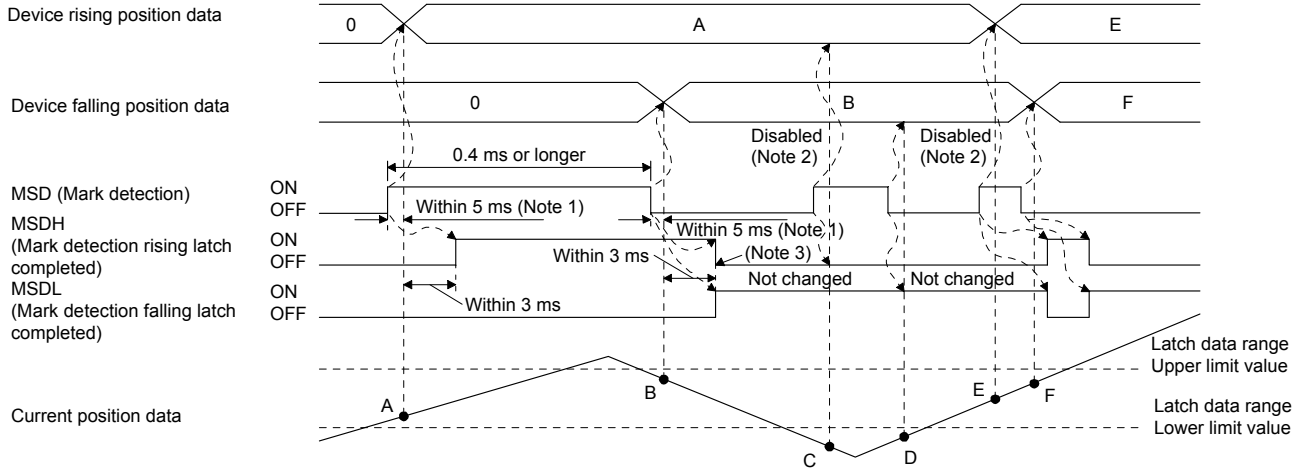

- Note 1. When MSD (Mark detection) is assigned to the CN1-10 pin with [Pr. PD44], current position data can be obtained in high speed (within 0.4 ms). When assigning MSD (Mark detection) to the CN1-11 pin, set "Mark detection fast input signal filter selection" in [Pr. PD31].
- Note 2. The position data will not be changed from the previous value.
- Note 3. MSDH (Latch completed at rising edge of mark detection) turns off at the same timing as MSDL (Latch completed at falling edge of mark detection) turns on. Set as MSDL turns on/off within the range of the latch data.

If MSD (Mark detection) was turned on again when the previous falling was out of the valid range, MSDH (Latch completed at rising edge of mark detection) will not change, but the position data will be updated. Refer to the following timing chart.

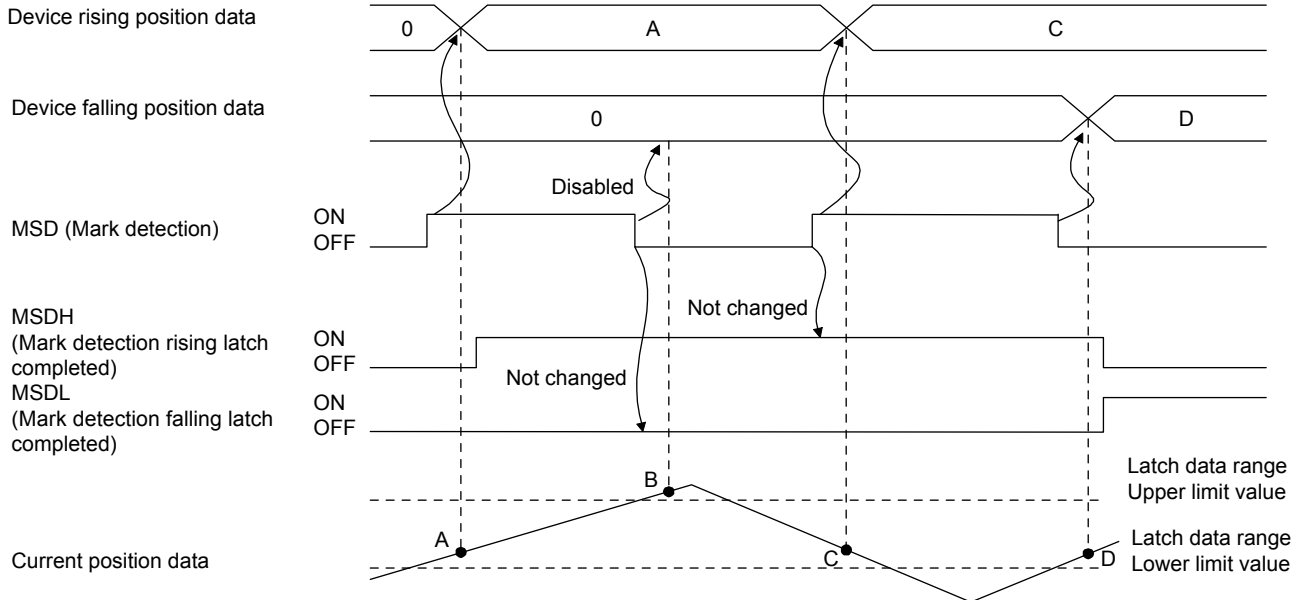

12. APPLICATION OF FUNCTIONS

12.2.2 Interrupt positioning function

The interrupt positioning function executes an operation by changing the remaining distance to the travel distance that is set with [Pr. PT30] and [Pr. PT31] (Mark sensor stop travel distance) when MSD (Mark detection) is turned on. The interrupt positioning function is enabled by setting [Pr. PT26] to "1 ___".

POINT
<ul style="list-style-type: none"> ● The interrupt positioning function is available with servo amplifiers with software version B7 or later. ● The interrupt positioning function can be used with the point table method and the program method. However, the interrupt positioning function is disabled in the following condition. <ul style="list-style-type: none"> ▪ During home position return ▪ During manual operation ▪ During stop ▪ During deceleration or stop with TSTP (Temporary stop/restart) ● An error may occur at the mark sensor stop position depending on the droop pulses of when MSD (Mark detection) is turned on and a minimum stopping distance required for deceleration.

(1) Parameter

Set the parameters as follows:

Item	Parameter to be used	Setting
Control mode selection	[Pr. PA01]	Select a control mode. ___ 6: Positioning mode (point table method) ___ 7: Positioning mode (program method)
Mark detection function selection	[Pr. PT26]	Set the mark detection function selection as follows: 1 ___: Interrupt positioning function Starts the interrupt positioning function at rising of MSD (Mark detection).
PI1 (Program input 1) Polarity selection to PI3 (Program input 3) Polarity selection	[Pr. PT29]	The polarity of MSD (Mark detection) can be changed with [Pr. PT29]. ▪ Starts the interrupt positioning function at rising of MSD (Mark detection) if "___x_" bit 3 of [Pr. PT29] is off. ▪ Starts the interrupt positioning function at falling of MSD (Mark detection) if "___x_" bit 3 of [Pr. PT29] is on.
Mark sensor stop travel distance (lower three digits)	[Pr. PT30]	Set the lower three digits of the travel distance after the mark detection. The travel distance starts from the current position regardless of the setting of absolute value command method or incremental value command method.
Mark sensor stop travel distance (upper three digits)	[Pr. PT31]	Set the upper three digits of the travel distance after the mark detection. The travel distance starts from the current position regardless of the setting of absolute value command method or incremental value command method.
Mark detection range + (lower three digits)	[Pr. PC66]	Set the upper and lower limits of the interrupt positioning function. If a sign for the upper and lower differ, [AL. 37] occurs. When the roll feed display is enabled, set this value with the travel distance from the starting position.
Mark detection range + (upper three digits)	[Pr. PC67]	
Mark detection range - (lower three digits)	[Pr. PC68]	
Mark detection range - (upper three digits)	[Pr. PC69]	

12. APPLICATION OF FUNCTIONS

(2) Rotation direction

[Pr. PA14] setting	Servo motor rotation direction ST1 (Forward rotation start) on
--- 0	CCW rotation with + position data CW rotation with - position data
--- 1	CW rotation with + position data CCW rotation with - position data

(3) Operation

Travels for the interrupt positioning travel distance ([Pr. PT30] and [Pr. PT31]) starting from the position where MSD (Mark detection) is turned on. The operation after a stop complies with the operation mode and the operation pattern.

(4) Timing chart

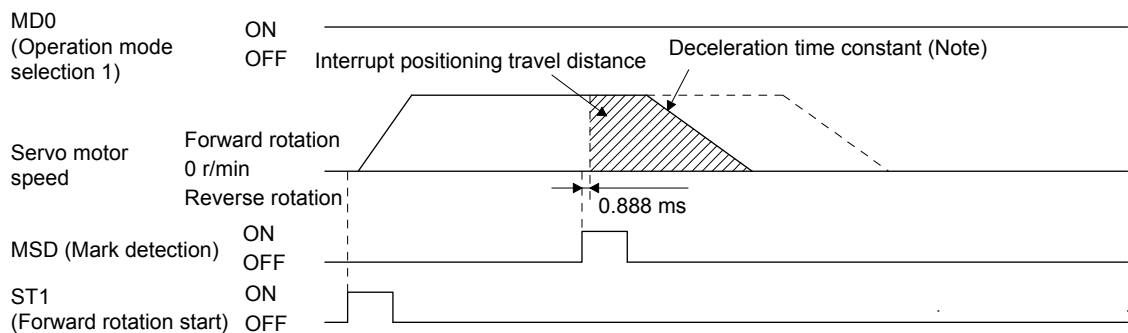

Note. Deceleration time constant of the point table at the time of start is applied for the point table method, and deceleration time constant set by the program in execution is applied for the program method.

The movement other than above is as follows:

- (a) When the interrupt positioning travel distance is smaller than the travel distance required for the deceleration, the actual deceleration time constant will be shorter than the set time constant.

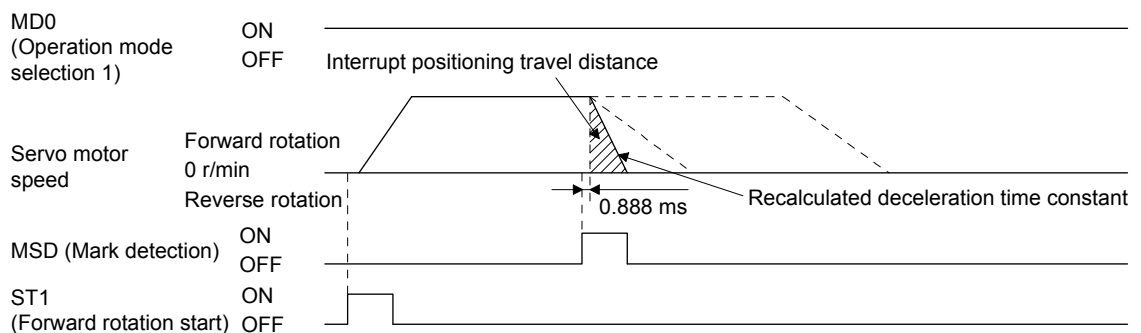

12. APPLICATION OF FUNCTIONS

- (b) When the interrupt travel distance is large during acceleration, the servo motor stops with the deceleration time constant after rotating with the command speed at which MSD (Mark detection) turned on.

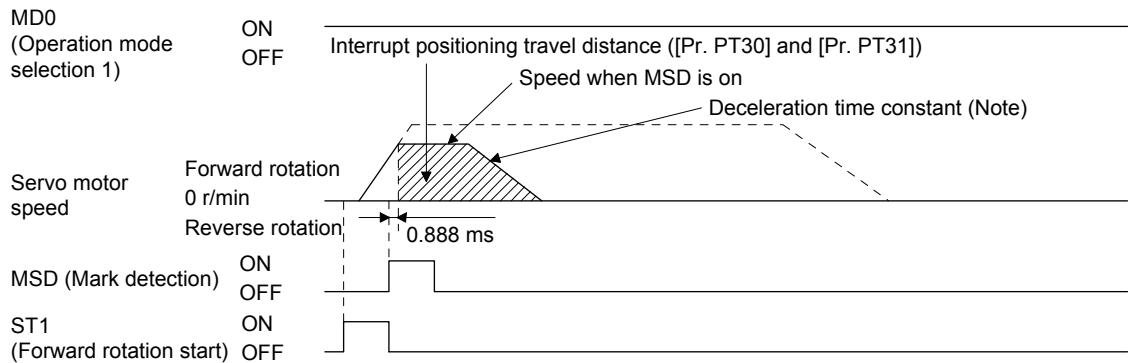

Note. Deceleration time constant of the point table at the time of start is applied for the point table method, and deceleration time constant set by the program in execution is applied for the program method.

- (c) When the interrupt travel distance is large during deceleration, the servo motor stops with the deceleration time constant after rotating with the command speed at which MSD (Mark detection) turned on.

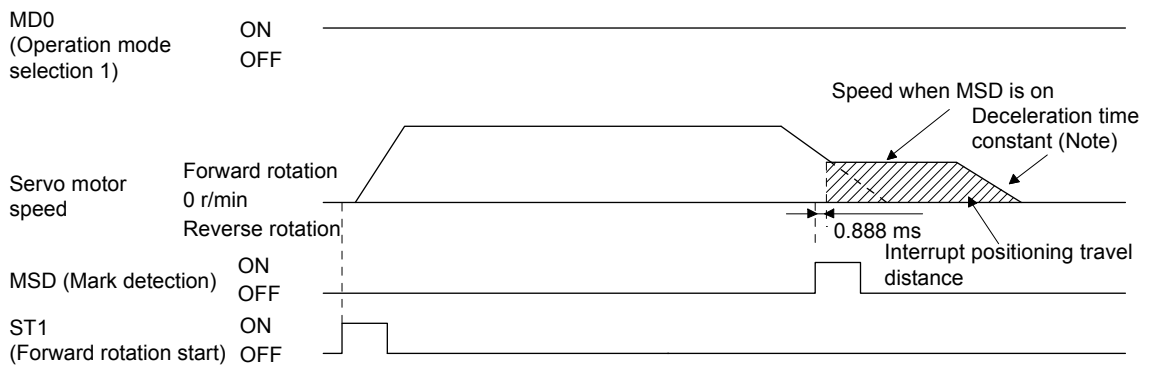

Note. Deceleration time constant of the point table at the time of start is applied for the point table method, and deceleration time constant set by the program in execution is applied for the program method.

- (d) When MSD (Mark detection) is turned on again during the interrupt positioning, the input will be disabled.

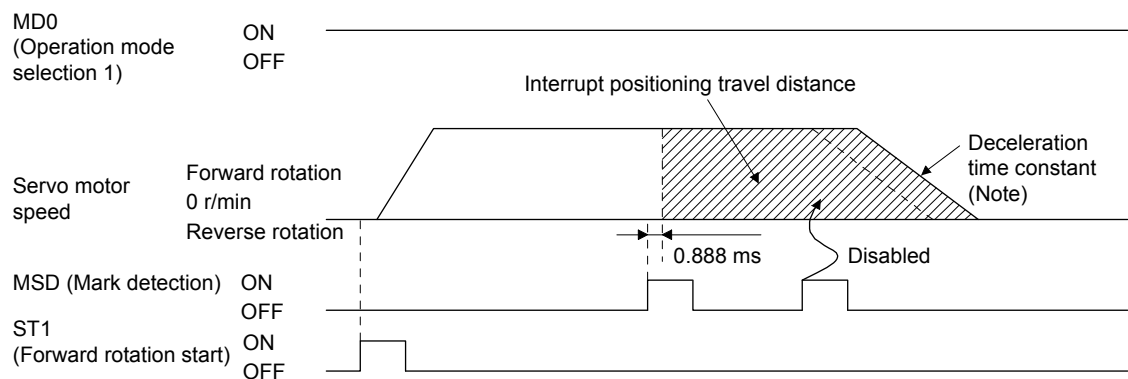

Note. Deceleration time constant of the point table at the time of start is applied for the point table method, and deceleration time constant set by the program in execution is applied for the program method.

12. APPLICATION OF FUNCTIONS

(5) Using together with other functions

Availability of other functions during the interrupt positioning is as follows:

Function	Availability (Note 1)
S-pattern acceleration/deceleration	○
Stroke limit	○
Software limit	○
Temporary stop/restart	×
Speed change value	×
Analog override	△ (Note 2)
Backlash	×
Rough match	○
Electronic gear	○
Roll feed display function	×
Mark detection function (current position latch function)	×

Note 1. ○: enabled, ×: disabled, △: enabled with condition
 2. Enabled only in a constant speed

ITP (Interrupt positioning) is available in the program method.

Because the interrupt positioning function with MSD (Mark detection) input signal is prioritized, the interrupt positioning function with MSD (Mark detection) can be used during the interrupt positioning function with ITP (Interrupt positioning). However, ITP (Interrupt positioning) cannot be used during the interrupt positioning with MSD (Mark detection).

12.3 Infinite feed function (setting degree)

POINT
<ul style="list-style-type: none"> ● This function can be used with the absolute position detection system. ● The infinite feed function (setting degree) is available with servo amplifiers with software version B7 or later. ● The infinite feed function (setting degree) can be used in the point table method and the program method.

When degree is set as the position data unit at the automatic operation or manual operation in the point table method or program method, [AL. E3.1 Multi-revolution counter travel distance excess warning] does not occur and the home position is not erased even if the servo motor rotates 32768 rev or more in the same direction. Thus, the current position is restored after the power is cycled. For other command units, [AL. E3.1 Multi-revolution counter travel distance excess warning] occurs and the home position is erased if the servo motor rotates 32768 rev or more in the same direction.

The following shows differences depending on the position data unit when the servo motor rotates 32768 rev or more in the same direction.

Parameter	Name	Setting digit	Setting value	Unit	[AL. E3.1]	Home position erasure	Current position restoration
PT01	Position data unit	_ x _ _	0	[mm]	It occurs.	Supported	Not supported
			1	[inch]	It occurs.	Supported	Not supported
			2	[degree]	It does not occur. (Note)	None (Note)	Supported (Note)
			3	[pulse]	It occurs.	Supported	Not supported

Note. For the servo amplifiers with software version B6 or earlier, [AL. E3.1] occurs and the home position is erased.

REVISION

*The manual number is given on the bottom left of the back cover.

Revision Date	*Manual Number	Revision
Apr. 2014	SH(NA)030143ENG -A	First edition
Aug. 2015	SH(NA)030143ENG -B	<p>MR-J4-03A6-RJ servo amplifier, MR-D01, compatibility to source pulses, interrupt positioning function, and infinite feed function (setting degree) are added.</p> <p>Safety Instructions Partially added and partially changed.</p> <p>Relevant manuals Relevant manuals are added.</p> <p>Chapter 1 Partially changed.</p> <p>Section 1.1 Partially added and partially changed.</p> <p>Section 1.2 Partially added and partially changed.</p> <p>Section 1.3 Partially added and partially changed.</p> <p>Section 1.4 Using MR-J4-03A6-RJ is added.</p> <p>Chapter 2 Partially changed.</p> <p>Section 2.1 Page arrangement is changed as MR-J4-03A6-RJ is added.</p> <p>Section 2.2 Sentences are added in the POINT, and using MR-J4-03A6-RJ are added.</p> <p>Section 2.3 Partially added.</p> <p>Section 2.3 (1) Partially added and partially changed.</p> <p>Section 2.3 (2) Partially added.</p> <p>Section 2.3 (3) (b) Using MR-J4-03A6-RJ is added.</p> <p>Section 2.3 (4) (b) Using MR-J4-03A6-RJ is added.</p> <p>Section 2.4 Partially changed.</p> <p>Section 2.5 The title is changed, a sentence is added in the POINT, and internal circuit of MR-J4-03A6-RJ is added.</p> <p>Section 2.5.2 Deleted.</p> <p>Section 2.5.3 Deleted.</p> <p>Section 2.6 Using MR-J4-03A6-RJ is added.</p> <p>Chapter 3 Page arrangement is changed as MR-J4-03A6-RJ is added. Partially changed.</p> <p>Section 3.2 Using MR-J4-03A6-RJ is added.</p> <p>Chapter 4 Sentences are added in the POINT. Partially changed.</p> <p>Section 4.1 Partially added and partially changed.</p> <p>Section 4.2 Partially added and partially changed.</p> <p>Section 4.3 Partially changed.</p> <p>Section 4.4 Partially changed.</p> <p>Section 4.5 Partially changed.</p> <p>Section 4.6 Partially changed.</p> <p>Chapter 5 Sentences are added in the POINT. Partially changed.</p> <p>Section 5.1 Partially changed.</p> <p>Section 5.2 Partially added and partially changed.</p> <p>Section 5.3 Partially changed.</p> <p>Section 5.4 Sentences are partially deleted from the POINT. Partially changed.</p> <p>Section 5.5 Partially added and partially changed.</p> <p>Section 5.6 Partially added and partially changed.</p> <p>Section 5.8 Partially changed.</p> <p>Chapter 6 Partially changed.</p> <p>Section 6.1 Partially added and partially changed.</p> <p>Section 6.2 Partially added and partially changed.</p> <p>Section 6.3 Partially added and partially changed.</p> <p>Section 6.4 Sentences are partially changed in the POINT. Partially changed.</p> <p>Chapter 7 POINT is added.</p>

Revision Date	*Manual Number	Revision	
Aug. 2015	SH(NA)030143ENG -B	Section 7.1	Sentences are added in the POINT. Partially added and partially changed.
		Section 7.2	Partially added and partially changed.
		Section 7.3.1	POINT is added. Partially changed.
		Section 7.3.2	Partially changed.
		Section 7.5	Partially changed.
		Section 7.6	Partially changed.
		Chapter 8	Partially changed.
		Section 8.2	Partially changed.
		Section 8.3	Partially added.
		Chapter 9	Partially changed.
		Chapter 10	The title is changed. Partially changed.
		Section 10.1	Partially added and partially changed.
		Section 10.2	Partially added and partially changed.
		Section 10.2.7	Deleted.
		Section 10.3	Partially added and partially changed.
		Chapter 11	Fully changed.
		Chapter 12	Newly added.
Nov. 2016	SH(NA)030143ENG-C	The details of the simple cam function are added.	
		3. To prevent injury, note the following	Partially changed.
		4. Additional instructions	
		(1) Transportation and installation	Partially changed.
		(2) Wiring	Partially added.
		(5) Corrective actions	Partially added.
		(6) Maintenance, inspection and parts replacement	Partially added and partially changed.
		Section 1.2	Partially changed.
		Section 1.3	Partially added and partially changed.
		Section 1.4	Partially added and partially changed.
		Section 2.2 (2)	The diagram is changed.
		Section 2.3 (1)	Partially changed.
		Section 3.1.1	Partially changed.
		Section 3.1.2 (2)	The note is changed.
		Section 3.1.9	Partially changed.
		Section 3.2.1	Partially changed.
		Chapter 4	Sentences are added in the POINT.
		Section 4.1.4	Sentences are added in the POINT.
		Section 4.2.2 (3) (e)	Partially changed.
		Section 4.2.2 (3) (f)	Partially changed.
		Section 4.4	A sentence is added in the POINT.
		Section 4.4.15	Newly added.
		Section 4.4.16	Newly added.
		Section 4.6	Partially changed.
		Section 5.1.4	Sentences are added in the POINT.
		Section 5.2.2 (1)	Partially changed.
		Section 5.2.2 (2) (g)	Partially changed.
		Section 5.2.2 (2) (h)	Partially changed.
		Section 5.2.2 (2) (k)	A sentence is added in the POINT.
		Section 5.4.4	Partially changed.
		Section 5.8	Partially changed.
		Chapter 6	Sentences are added in the POINT.
		Section 6.1.4	Sentences are added in the POINT. A note is added.

Revision Date	*Manual Number	Revision	
Nov. 2016	SH(NA)030143ENG-C	Section 6.2.2 (4) Section 6.2.3 (4) Section 6.4 Section 6.4.2 Section 7.1 Section 7.2 Section 8.2 Section 10.3 Chapter 11 Section 11.2.1 Section 11.2.2 Section 11.3 Section 11.5.1 Section 11.5.1 (1) Section 12.1	The diagram is changed. The diagram is changed. A sentence is added in the POINT. Partially changed. [Pr. PA22] is added. Partially changed. Partially added and partially changed. Partially added. Partially changed. A sentence is added and partially changed in the POINT. The diagram is changed. Partially changed. Partially changed. The diagrams are changed. The notes are changed. Partially changed. The composition is changed and the contents are added.

This manual confers no industrial property rights or any rights of any other kind, nor does it confer any patent licenses. Mitsubishi Electric Corporation cannot be held responsible for any problems involving industrial property rights which may occur as a result of using the contents noted in this manual.

Country/Region	Sales office	Tel/Fax
USA	Mitsubishi Electric Automation, Inc. 500 Corporate Woods Parkway, Vernon Hills, IL 60061, U.S.A.	Tel : +1-847-478-2100 Fax : +1-847-478-2253
Mexico	Mitsubishi Electric Automation, Inc. Mexico Branch Mariano Escobedo #69, Col. Zona Industrial, Tlalnepantla Edo. Mexico, C.P.54030	Tel : +52-55-3067-7500 Fax : -
Brazil	Mitsubishi Electric do Brasil Comercio e Servicos Ltda. Avenida Adelino Cardana, 293, 21 andar, Bethaville, CEP 06401-147, Barueri SP, Brazil	Tel : +55-11-4689-3000 Fax : +55-11-4689-3016
Germany	Mitsubishi Electric Europe B.V. German Branch Mitsubishi-Electric-Platz 1, 40882 Ratingen, Germany	Tel : +49-2102-486-0 Fax : +49-2102-486-1120
UK	Mitsubishi Electric Europe B.V. UK Branch Travellers Lane, UK-Hatfield, Hertfordshire, AL10 8XB, U.K.	Tel : +44-1707-28-8780 Fax : +44-1707-27-8695
Italy	Mitsubishi Electric Europe B.V. Italian Branch Centro Direzionale Colleoni - Palazzo Sirio, Viale Colleoni 7, 20864 Agrate Brianza (MB), Italy	Tel : +39-039-60531 Fax : +39-039-6053-312
Spain	Mitsubishi Electric Europe B.V. Spanish Branch Carretera de Rubi, 76-80-Apdo. 420, 08190 Sant Cugat del Valles (Barcelona), Spain	Tel : +34-935-65-3131 Fax : +34-935-89-1579
France	Mitsubishi Electric Europe B.V. French Branch 25, Boulevard des Bouvets, 92741 Nanterre Cedex, France	Tel : +33-1-55-68-55-68 Fax : +33-1-55-68-57-57
Czech Republic	Mitsubishi Electric Europe B.V. Czech Branch Avenir Business Park, Radlicka 751/113e, 158 00 Praha 5, Czech Republic	Tel : +420-251-551-470 Fax : +420-251-551-471
Poland	Mitsubishi Electric Europe B.V. Polish Branch ul. Krakowska 50, 32-083 Balice, Poland	Tel : +48-12-347-65-00 Fax : +48-12-630-47-01
Russia	Mitsubishi Electric (Russia) LLC St. Petersburg Branch Piskarevsky pr. 2, bld 2, lit "Sch", BC "Benua", office 720; 195027 St. Petersburg, Russia	Tel : +7-812-633-3497 Fax : +7-812-633-3499
Sweden	Mitsubishi Electric Europe B.V. (Scandinavia) Fjellievagen 8, SE-22736 Lund, Sweden	Tel : +46-8-625-10-00 Fax : +46-46-39-70-18
Turkey	Mitsubishi Electric Turkey A.S. Umraniye Branch Serifali Mahallesi Nutuk Sokak No:5, TR-34775 Umraniye / Istanbul, Turkey	Tel : +90-216-526-3990 Fax : +90-216-526-3995
UAE	Mitsubishi Electric Europe B.V. Dubai Branch Dubai Silicon Oasis, P.O.BOX 341241, Dubai, U.A.E.	Tel : +971-4-3724716 Fax : +971-4-3724721
South Africa	Adroit Technologies 20 Waterford Office Park, 189 Witkoppen Road, Fourways, South Africa	Tel : +27-11-658-8100 Fax : +27-11-658-8101
China	Mitsubishi Electric Automation (China) Ltd. Mitsubishi Electric Automation Center, No.1386 Hongqiao Road, Shanghai, China	Tel : +86-21-2322-3030 Fax : +86-21-2322-3000
Taiwan	SETSUYO ENTERPRISE CO., LTD. 6F, No.105, Wugong 3rd Road, Wugu District, New Taipei City 24889, Taiwan	Tel : +886-2-2299-2499 Fax : +886-2-2299-2509
Korea	Mitsubishi Electric Automation Korea Co., Ltd. 7F-9F, Gangseo Hangang Xi-tower A, 401, Yangcheon-ro, Gangseo-Gu, Seoul 07528, Korea	Tel : +82-2-3660-9510 Fax : +82-2-3664-8372/8335
Singapore	Mitsubishi Electric Asia Pte. Ltd. 307 Alexandra Road, Mitsubishi Electric Building, Singapore 159943	Tel : +65-6473-2308 Fax : +65-6476-7439
Thailand	Mitsubishi Electric Factory Automation (Thailand) Co., Ltd. 12th Floor, SV.City Building, Office Tower 1, No. 896/19 and 20 Rama 3 Road, Kwaeng Bangpongpan, Khet Yannawa, Bangkok 10120, Thailand	Tel : +66-2682-6522 to 6531 Fax : +66-2682-6020
Indonesia	PT. Mitsubishi Electric Indonesia Gedung Jaya 11th Floor, JL. MH. Thamrin No.12, Jakarta Pusat 10340, Indonesia	Tel : +62-21-3192-6461 Fax : +62-21-3192-3942
Vietnam	Mitsubishi Electric Vietnam Company Limited Unit 01-04, 10th Floor, Vincom Center, 72 Le Thanh Ton Street, District 1, Ho Chi Minh City, Vietnam	Tel : +84-8-3910-5945 Fax : +84-8-3910-5947
India	Mitsubishi Electric India Pvt. Ltd. Pune Branch Emerald House, EL-3, J Block, M.I.D.C., Bhosari, Pune - 411026, Maharashtra, India	Tel : +91-20-2710-2000 Fax : +91-20-2710-2100
Australia	Mitsubishi Electric Australia Pty. Ltd. 348 Victoria Road, P.O. Box 11, Rydalmere, N.S.W 2116, Australia	Tel : +61-2-9684-7777 Fax : +61-2-9684-7245
Japan	Mitsubishi Electric Co., Ltd. Tokyo Building, 2-7-3, Marunouchi, Chiyoda-ku, Tokyo 100-8310, Japan	Tel : +81-3-3218-2111

MELSERVO is a trademark or registered trademark of Mitsubishi Electric Corporation in Japan and/or other countries.
Modbus is registered trademark of SCHNEIDER ELECTRIC USA, INC.
All other product names and company names are trademarks or registered trademarks of their respective companies.

Warranty

1. Warranty period and coverage

We will repair any failure or defect hereinafter referred to as "failure" in our FA equipment hereinafter referred to as the "Product" arisen during warranty period at no charge due to causes for which we are responsible through the distributor from which you purchased the Product or our service provider. However, we will charge the actual cost of dispatching our engineer for an on-site repair work on request by customer in Japan or overseas countries. We are not responsible for any on-site readjustment and/or trial run that may be required after a defective unit are repaired or replaced.

[Term]

The term of warranty for Product is twelve (12) months after your purchase or delivery of the Product to a place designated by you or eighteen (18) months from the date of manufacture whichever comes first ("Warranty Period"). Warranty period for repaired Product cannot exceed beyond the original warranty period before any repair work.

[Limitations]

- (1) You are requested to conduct an initial failure diagnosis by yourself, as a general rule.
It can also be carried out by us or our service company upon your request and the actual cost will be charged. However, it will not be charged if we are responsible for the cause of the failure.
- (2) This limited warranty applies only when the condition, method, environment, etc. of use are in compliance with the terms and conditions and instructions that are set forth in the instruction manual and user manual for the Product and the caution label affixed to the Product.
- (3) Even during the term of warranty, the repair cost will be charged on you in the following cases;
 - (i) a failure caused by your improper storing or handling, carelessness or negligence, etc., and a failure caused by your hardware or software problem
 - (ii) a failure caused by any alteration, etc. to the Product made on your side without our approval
 - (iii) a failure which may be regarded as avoidable, if your equipment in which the Product is incorporated is equipped with a safety device required by applicable laws and has any function or structure considered to be indispensable according to a common sense in the industry
 - (iv) a failure which may be regarded as avoidable if consumable parts designated in the instruction manual, etc. are duly maintained and replaced
 - (v) any replacement of consumable parts (battery, fan, smoothing capacitor, etc.)
 - (vi) a failure caused by external factors such as inevitable accidents, including without limitation fire and abnormal fluctuation of voltage, and acts of God, including without limitation earthquake, lightning and natural disasters
 - (vii) a failure generated by an unforeseeable cause with a scientific technology that was not available at the time of the shipment of the Product from our company
 - (viii) any other failures which we are not responsible for or which you acknowledge we are not responsible for

2. Term of warranty after the stop of production

- (1) We may accept the repair at charge for another seven (7) years after the production of the product is discontinued. The announcement of the stop of production for each model can be seen in our Sales and Service, etc.
- (2) Please note that the Product (including its spare parts) cannot be ordered after its stop of production.

3. Service in overseas countries

Our regional FA Center in overseas countries will accept the repair work of the Product. However, the terms and conditions of the repair work may differ depending on each FA Center. Please ask your local FA center for details.

4. Exclusion of loss in opportunity and secondary loss from warranty liability

Regardless of the gratis warranty term, Mitsubishi shall not be liable for compensation to:

- (1) Damages caused by any cause found not to be the responsibility of Mitsubishi.
- (2) Loss in opportunity, lost profits incurred to the user by Failures of Mitsubishi products.
- (3) Special damages and secondary damages whether foreseeable or not, compensation for accidents, and compensation for damages to products other than Mitsubishi products.
- (4) Replacement by the user, maintenance of on-site equipment, start-up test run and other tasks.

5. Change of Product specifications

Specifications listed in our catalogs, manuals or technical documents may be changed without notice.

6. Application and use of the Product

- (1) For the use of our General-Purpose AC Servo, its applications should be those that may not result in a serious damage even if any failure or malfunction occurs in General-Purpose AC Servo, and a backup or fail-safe function should operate on an external system to General-Purpose AC Servo when any failure or malfunction occurs.
- (2) Our General-Purpose AC Servo is designed and manufactured as a general purpose product for use at general industries. Therefore, applications substantially influential on the public interest for such as atomic power plants and other power plants of electric power companies, and also which require a special quality assurance system, including applications for railway companies and government or public offices are not recommended, and we assume no responsibility for any failure caused by these applications when used.
In addition, applications which may be substantially influential to human lives or properties for such as airlines, medical treatments, railway service, incineration and fuel systems, man-operated material handling equipment, entertainment machines, safety machines, etc. are not recommended, and we assume no responsibility for any failure caused by these applications when used. We will review the acceptability of the abovementioned applications, if you agree not to require a specific quality for a specific application. Please contact us for consultation.

MODEL	MR-J4-A-RJ INSTRUCTIONMANUAL(ITIGIME)
MODEL CODE	1CW819

MITSUBISHI ELECTRIC CORPORATION

HEAD OFFICE : TOKYO BLDG MARUNOUCHI TOKYO 100-8310